

# RM600DY-66S

HIGH POWER SWITCHING USE  
INSULATED TYPE

HVDi (High Voltage Diode) Module

## RM600DY-66S



- IDC .....600A
- VRRM ..... 3300V
- Insulated type
- 2-element in a pack

## APPLICATION

3-level inverters, 3-level converters, DC choppers.

## OUTLINE DRAWING & CIRCUIT DIAGRAM

Dimensions in mm

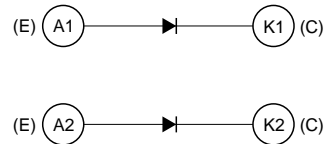
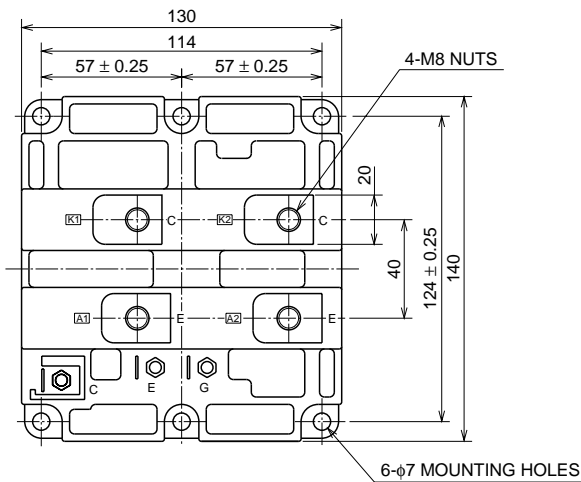

CIRCUIT DIAGRAM

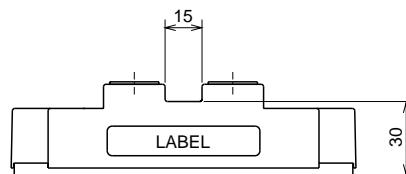
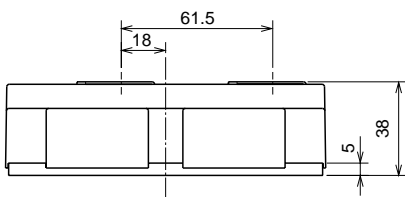

**RM600DY-66S**

**HIGH POWER SWITCHING USE  
INSULATED TYPE**

HVDi (High Voltage Diode) Module

**ABSOLUTE MAXIMUM RATINGS (T<sub>j</sub> = 25°C)**

Symbol	Item	Voltage class		Unit
		66		
VRRM	Repetitive peak reverse voltage	3300		V
VRSM	Non-repetitive peak reverse voltage	3300		V
VR(DC)	Reverse DC voltage	2200		V

Symbol	Item	Conditions	Ratings	Unit
I <sub>DC</sub>	Output DC current	T <sub>c</sub> = 25°C	600	A
I <sub>FSM</sub>	Surge (non-repetitive) forward current	1 cycle of half wave 60Hz, peak value, non-repetitive, T <sub>j</sub> = 25°C start, V <sub>RM</sub> = 0V	4800	A
I <sup>2</sup> <sub>t</sub>	I <sup>2</sup> <sub>t</sub> for fusing	Value of one cycle surge current, tw = 8.3ms, T <sub>j</sub> = 25°C start	9.60 × 10 <sup>4</sup>	A <sup>2</sup> s
T <sub>j</sub>	Junction temperature	—	-40 ~ +150	°C
T <sub>stg</sub>	Storage temperature	—	-40 ~ +125	°C
V <sub>iso</sub>	Isolation Voltage	Charged part to base plate, rms, sinusoidal, AC 60Hz 1min.	6000	V
—	Mounting torque	Main terminals screw M8	6.67 ~ 13.00	N · m
—		Mounting screw M6	2.84 ~ 6.00	N · m
—	Mass	Typical value	1.5	kg

**ELECTRICAL CHARACTERISTICS (T<sub>j</sub> = 25°C)**

Symbol	Item	Test conditions	Limits			Unit
			Min	Typ	Max	
I <sub>RRM</sub>	Repetitive reverse current	VRRM applied, V <sub>RM</sub> = VRRM	—	—	4	mA
V <sub>FM</sub>	Forward voltage	I <sub>FM</sub> = 600A	—	3.50	4.55	V
t <sub>rr</sub>	Reverse recovery time	I <sub>FM</sub> = 600A, di/dt = -1200A/μs,	—	—	1.20	μs
Q <sub>rr</sub>	Reverse recovery charge	V <sub>R</sub> = 1650V	—	150	—	μC
R <sub>th(j-c)</sub>	Thermal resistance	Junction to case (Per 1/2 module)	—	—	0.048	K/W
R <sub>th(c-f)</sub>	Contact thermal resistance	Case to fin, conductive grease applied (Per 1/2 module)	—	0.024	—	K/W

**RM600DY-66S**

**HIGH POWER SWITCHING USE  
INSULATED TYPE**

HVDi (High Voltage Diode) Module

**PERFORMANCE CURVES**

81.563

