

# Customer Information Sheet

DRAWING No.: M80-336 TO M80-337

SHEET 2 OF 2

IF IN DOUBT - ASK

(C)

NOT TO SCALE

THIRD ANGLE PROJECTION

ALL DIMENSIONS IN mm

**SPECIFICATIONS:**

**MATERIALS:**

BODY = COPPER ALLOY

LATCHING COLLAR = BERYLLIUM COPPER

**FINISH:**

BODY = GOLD

LATCHING COLLAR = NICKEL

**ELECTRICAL:**

CONTACT RESISTANCE =  $6m\Omega$  MAX

CURRENT RATING = SEE TABLE (CABLE DEPENDENT)

**MECHANICAL:**

DURABILITY = 500 OPERATIONS

INSERTION FORCE = 5N MAX, 0.6N MIN

WITHDRAWAL FORCE = 2N MAX, 0.5N MIN

CONTACT REPLACEMENT IN INSULATOR = 5 TIMES

**ENVIRONMENTAL:**

TEMPERATURE RANGE = -55°C TO +125°C

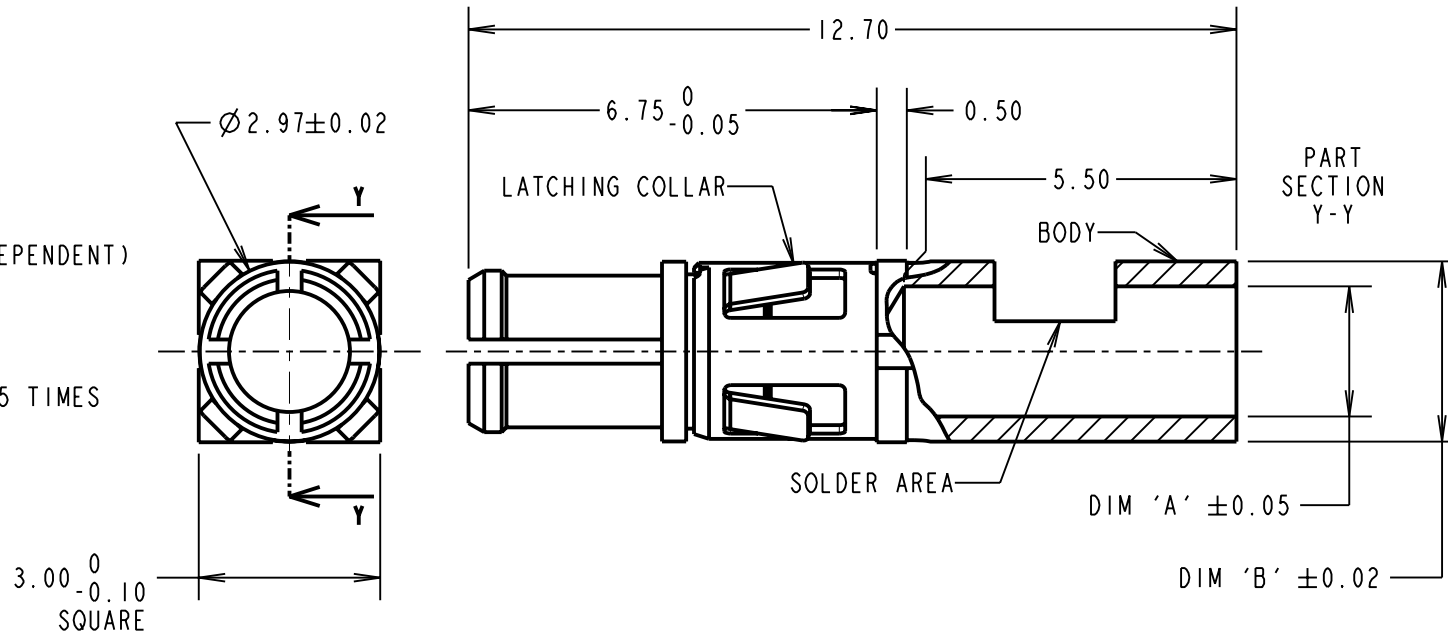
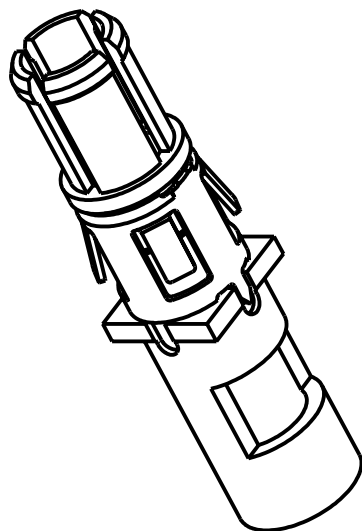

**NOTES:**

- CONNECTOR COMES SUPPLIED ASSEMBLED.
- STRIP WIRE BY 5.00mm MINIMUM.
- CONTACT EXTRACTION TOOL = Z80-290
- FOR ALL OTHER ELECTRICAL/MECHANICAL REQUIREMENTS, SEE COMPONENT SPECIFICATION C005XX (LATEST ISSUE).

PART No.	DIM 'A'	DIM 'B'	WIRE SIZE	CURRENT RATING
M80-336	∅2.15	∅2.98	14 AWG (19/0.30 OR 19/0.34)	15A
M80-337	∅1.75	∅2.98	16 AWG (19/0.25 OR 19/0.30)	10A

MGP	5	24.03.10	10713
NAME	ISS.	DATE	C/NOTE
APPROVED: MGP			
CHECKED: RA			
DRAWN: W. J. BOURNE			
CUSTOMER REF.:			
ASSEMBLY DRG:			

**HARWIN**

HARWIN USA  
TEL: 603 893 5376  
FAX: 603 893 5396  
mis@harwin.com

HARWIN Europe (UK)  
TEL: 023 9231 4545  
FAX: 023 9231 4590  
mis@harwin.co.uk

HARWIN Asia  
TEL: +65 6 779 4909  
FAX: +65 6 779 3868  
mis@harwin.com.sg

THIS DRAWING AND ANY INFORMATION OR DESCRIPTIVE MATTER SET OUT HEREON ARE CONFIDENTIAL AND COPYRIGHT PROPERTY OF THE HARWIN GROUP AND MUST NOT BE DISCLOSED, LOANED, COPIED OR USED FOR MANUFACTURING, TENDERING OR FOR ANY OTHER PURPOSE WITHOUT THEIR WRITTEN PERMISSION.

**TOLERANCES**  
X. = ±1mm  
X.X = ±0.25mm  
X.XX = ±0.10mm  
X.XXX = ±0.01mm  
  
ANGLES = ±5°  
UNLESS STATED

**MATERIAL:**  
SEE ABOVE  
  
**FINISH:** SEE ABOVE  
  
**S/AREA:** mm<sup>2</sup>

**TITLE:** DATAMATE MIX-TEK  
POWER CONTACT  
MALE STRAIGHT SOLDER  
  
**DRAWING NUMBER:**  
**M80-336 TO M80-337**  
  
SHT 2 OF 2