

Customer Information Sheet

DRAWING No.: M80-315 TO M80-317

SHEET 2 OF 2

IF IN DOUBT - ASK

©

NOT TO SCALE

THIRD ANGLE PROJECTION

ALL DIMENSIONS IN mm

SPECIFICATIONS:

MATERIALS:

BODY, SLEEVE, INNER CONTACT
= COPPER ALLOY

LATCHING COLLAR = BERYLLIUM COPPER

INSULATOR = PTFE

FINISH:

BODY, SLEEVE, INNER CONTACT = GOLD

LATCHING COLLAR = NICKEL

ELECTRICAL:

FREQUENCY RANGE = 6GHz

IMPEDANCE = 50Ω

V.S.W.R. = 1.05 + (0.04 x FREQUENCY) GHz MAX

CONTACT RESISTANCE = 6mΩ MAX

INSULATION RESISTANCE = 10⁶MΩ @250V AC

OPERATING VOLTAGE = 180V AC @ 500mA

MAXIMUM VOLTAGE = 1,000V AC

MECHANICAL:

DURABILITY = 500 OPERATIONS

INSERTION FORCE = 5N MAX, 0.6N MIN

WITHDRAWAL FORCE = 2N MAX, 0.5N MIN

CONTACT REPLACEMENT IN INSULATOR = 5 TIMES

ENVIRONMENTAL:

TEMPERATURE RANGE = -55°C TO +125°C

NOTES:

- CONNECTOR COMES SUPPLIED AS A KIT OF PARTS: BODY, INSULATOR, AND LATCHING COLLAR ARE PRE-ASSEMBLED, SLEEVE AND INNER CONTACT ARE SEPARATE.
- RECOMMENDED HAND CRIMP TOOL FOR INNER CONTACT = Z80-292 WITH POSITIONER Z80-291. RECOMMENDED HAND CRIMP TOOL AND DIE SET FOR SLEEVE = Z80-293.
- CONTACT EXTRACTION TOOL = Z80-290
- FOR ALL OTHER ELECTRICAL/MECHANICAL REQUIREMENTS, SEE COMPONENT SPECIFICATION C005XX (LATEST ISSUE).

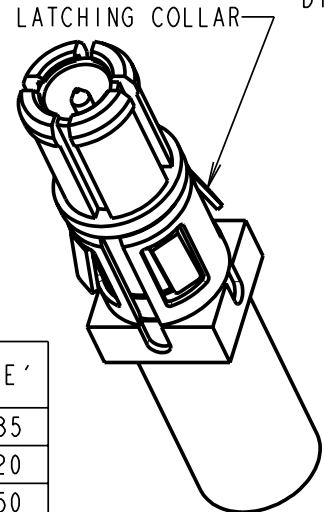
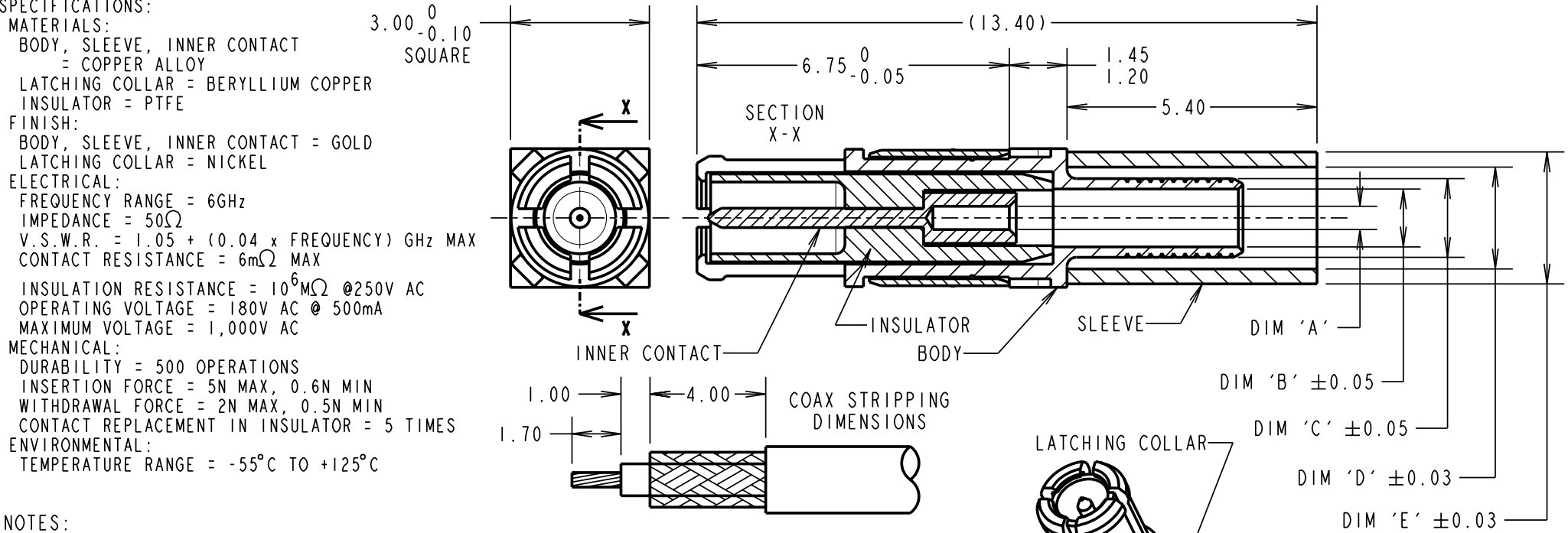

MGP	3	27.01.09	10272
NAME	ISS.	DATE	C/NOTE
APPROVED: MGP			
CHECKED: RA			
DRAWN: W. J. BOURNE			
CUSTOMER REF.:			
ASSEMBLY DRG:			

PART No.	CABLE DIAMETER (TYPE)	DIM 'A'	DIM 'B'	DIM 'C'	DIM 'D'	DIM 'E'
M80-315	∅2.0mm (RG178)	∅0.50 ±0.05	∅1.25	∅1.70	∅2.20	∅2.85
M80-316	∅2.4mm (PTFE CELLULAR)	∅0.35 +0.05/-0	∅1.25	∅1.70	∅2.70	∅3.20
M80-317	∅2.7mm (RG174, 179, 316)	∅0.70 ±0.05	∅1.75	∅2.35	∅2.85	∅3.50

HARWIN

HARWIN USA TEL: 603 893 5376 FAX: 603 893 5396 mis@harwin.com	HARWIN Europe (UK) TEL: 023 9231 4545 FAX: 023 9231 4590 mis@harwin.co.uk	HARWIN Asia TEL: +65 6 779 4909 FAX: +65 6 779 3868 mis@harwin.com.sg
--	--	--

THIS DRAWING AND ANY INFORMATION OR DESCRIPTIVE MATTER SET OUT HEREON ARE CONFIDENTIAL AND COPYRIGHT PROPERTY OF THE HARWIN GROUP AND MUST NOT BE DISCLOSED, LOANED, COPIED OR USED FOR MANUFACTURING, TENDERING OR FOR ANY OTHER PURPOSE WITHOUT THEIR WRITTEN PERMISSION.

TOLERANCES
X. = ±1mm
X.X = ±0.25mm
X.XX = ±0.10mm
X.XXX = ±0.01mm
ANGLES = ±5°
UNLESS STATED

MATERIAL:
SEE ABOVE
FINISH: SEE ABOVE
S/AREA: mm²

TITLE: DATAMATE MIX-TEK
COAX CONTACT
MALE STRAIGHT CRIMP
DRAWING NUMBER:
M80-315 TO M80-317
SHT 2 OF 2