



**128Mx64 bits
Unbuffered DDR SO-DIMM**

HYMD512M646B(L)F8-J/M/K/H/L

**Document Title
128Mx64 bits Unbuffered DDR SO-DIMM**

Revision History

No.	History	Draft Date	Remark
0.1	Initial Draft	Jan. 2004	
0.2	IDD3P Value Adjusted from 216 to 192 [mA] at Page 9	Apr. 2004	
0.3	Reflected a "notational" change in module thickness on page 17 - Not Real ! -	Apr. 2004	



128Mx64 bits Unbuffered DDR SO-DIMM

HYMD512M646B(L)F8-J/M/K/H/L

DESCRIPTION

Hynix HYMD512M646B(L)F8-J/M/K/H/L series is unbuffered 200-pin double data rate Synchronous DRAM Small Outline Dual In-Line Memory Modules (SO-DIMMs) which are organized as 128Mx64 high-speed memory arrays. Hynix HYMD512M646B(L)F8-J/M/K/H/L series consists of Sixteen 64Mx8 DDR SDRAM in FBGA packages on a 200pin glass-epoxy substrate. Hynix HYMD512M646B(L)F8-J/M/K/H/L series provide a high performance 8-byte interface in 67.60mmX 31.75mm form factor of industry standard. It is suitable for easy interchange and addition.

Hynix HYMD512M646B(L)F8-J/M/K/H/L series is designed for high speed of up to 166MHz and offers fully synchronous operations referenced to both rising and falling edges of differential clock inputs. While all addresses and control inputs are latched on the rising edges of the clock, Data, Data strobes and Write data masks inputs are sampled on both rising and falling edges of it. The data paths are internally pipelined and 2-bit prefetched to achieve very high bandwidth. All input and output voltage levels are compatible with SSTL_2. High speed frequencies, programmable latencies and burst lengths allow variety of device operation in high performance memory system.

Hynix HYMD512M646B(L)F8-J/M/K/H/L series incorporates SPD(serial presence detect). Serial presence detect function is implemented via a serial 2,048-bit EEPROM. The first 128 bytes of serial PD data are programmed by Hynix to identify DIMM type, capacity and other the information of DIMM and the last 128 bytes are available to the customer.

FEATURES

- 1GB (128M x 64) Unbuffered DDR SO-DIMM based on 64Mx8 DDR SDRAM
- 200-pin small outline dual in-line memory module (SO-DIMM)
- 2.5V +/- 0.2V VDD and VDDQ Power supply
- All inputs and outputs are compatible with SSTL_2 interface
- Fully differential clock operations (CK & /CK) with 100/133/166MHz
- All addresses and control inputs except Data, Data strobes and Data masks latched on the rising edges of the clock
- Data(DQ), Data strobes and Write masks latched on both rising and falling edges of the clock
- Data inputs on DQS centers when write (centered DQ)
- Data strobes synchronized with output data for read and input data for write
- Programmable CAS Latency 2 / 2.5 supported
- Programmable Burst Length 2 / 4 / 8 with both sequential and interleave mode
- tRAS Lock-out function supported
- Internal four bank operations with single pulsed RAS
- Auto refresh and self refresh supported
- 8192 refresh cycles / 64ms

ORDERING INFORMATION

Part No.	Power Supply	Clock Frequency	Interface	Form Factor
HYMD512M646B(L)F8-J	VDD=2.5V VDDQ=2.5V	166MHz (*DDR333)	SSTL_2	200pin Unbuffered SO-DIMM 67.6mm x 31.75mm x 1mm
HYMD512M646B(L)F8-M		133MHz (*DDR266:2-2-2)		
HYMD512M646B(L)F8-K		133MHz (*DDR266A)		
HYMD512M646B(L)F8-H		133MHz (*DDR266B)		
HYMD512M646B(L)F8-L		100MHz (*DDR200)		

* JEDEC Defined Specifications compliant

This document is a general product description and is subject to change without notice. Hynix Semiconductor does not assume any responsibility for use of circuits described. No patent licenses are implied.

PIN DESCRIPTION

Pin	Pin Description	Pin	Pin Description
CK0, /CK0, CK1, /CK1	Differential Clock Inputs	VDDQ	DQs Power Supply
CS0, CS1	Chip Select Input	VSS	Ground
CKE0, CKE1	Clock Enable Input	VREF	Reference Power Supply
/RAS, /CAS, /WE	Command Sets Inputs	VDDSPD	Power Supply for SPD
A0 ~ A12	Address	SA0~SA2	E ² PROM Address Inputs
BA0, BA1	Bank Address	SCL	E ² PROM Clock
DQ0~DQ63	Data Inputs/Outputs	SDA	E ² PROM Data I/O
DQS0~DQS7	Data Strobe Inputs/Outputs	VDDID	VDD Identification Flag
DM0~DM7	Data-in Mask	DU	Do not Use
VDD	Power Supply	NC	No Connection

PIN ASSIGNMENT

Pin	Name	Pin	Name	Pin	Name	Pin	Name	Pin	Name	Pin	Name	Pin	Name
1	VREF	2	VREF	51	VSS	52	VSS	101	A9	102	A8	151	DQ42
3	VSS	4	VSS	53	DQ19	54	DQ23	103	VSS	104	VSS	153	DQ43
5	DQ0	6	DQ4	55	DQ24	56	DQ28	105	A7	106	A6	155	VDD
7	DQ1	8	DQ5	57	VDD	58	VDD	107	A5	108	A4	157	VDD
9	VDD	10	VDD	59	DQ25	60	DQ29	109	A3	110	A2	158	/CK1
11	DQS0	12	DM0	61	DQS3	62	DM3	111	A1	112	A0	159	VSS
13	DQ2	14	DQ6	63	VSS	64	VSS	113	VDD	114	VDD	161	VSS
15	VSS	16	VSS	65	DQ26	66	DQ30	115	A10/AP	116	BA1	162	VSS
17	DQ3	18	DQ7	67	DQ27	68	DQ31	117	BA0	118	/RAS	163	DQ48
19	DQ8	20	DQ12	69	VDD	70	VDD	119	/WE	120	/CAS	164	DQ52
21	VDD	22	VDD	71	NC	72	NC	121	/CS0	122	/CS1	165	DQ49
23	DQ9	24	DQ13	73	NC	74	NC	123	NC	124	DU	166	DQ53
25	DQS1	26	DM1	75	VSS	76	VSS	125	VSS	126	VSS	167	VDD
27	VSS	28	VSS	77	NC	78	NC	127	DQ32	128	DQ36	168	VDD
29	DQ10	30	DQ14	79	NC	80	NC	129	DQ33	130	DQ37	169	VDD
31	DQ11	32	DQ15	81	VDD	82	VDD	131	VDD	132	VDD	170	DM6
33	VDD	34	VDD	83	NC	84	NC	133	DQS4	134	DM4	171	DQ50
35	CK0	36	VDD	85	DU	86	DU	135	DQ34	136	DQ38	172	DQ54
37	/CK0	38	VSS	87	VSS	88	VSS	137	VSS	138	VSS	173	VSS
39	VSS	40	VSS	89	NC	90	VSS	139	DQ35	140	DQ39	174	VSS
41	DQ16	42	DQ20	91	NC	92	VDD	141	DQ40	142	DQ44	175	DQ51
43	DQ17	44	DQ21	93	VDD	94	VDD	143	VDD	144	VDD	176	DQ55
45	VDD	46	VDD	95	CKE1	96	CKE0	145	DQ41	146	DQ45	177	DQ56
47	DQS2	48	DM2	97	NC	98	DU	147	DQS5	148	DM5	178	DQ60
49	DQ18	50	DQ22	99	A12	100	A11	149	VSS	150	VSS	179	VDD
												180	VDD
												181	DQ57
												182	DQ61
												183	DQS7
												184	DM7
												185	VSS
												186	VSS
												187	DQ58
												188	DQ62
												189	DQ59
												190	DQ63
												191	VDD
												192	VDD
												193	SDA
												194	SA0
												195	SCL
												196	SA1
												197	VDDSPD
												198	SA2
												199	VDDID
												200	DU

FUNCTIONAL BLOCK DIAGRAM

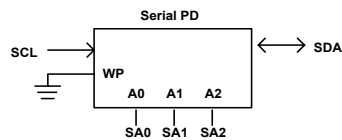
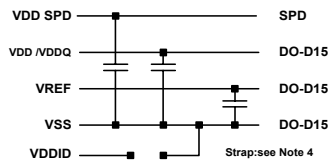
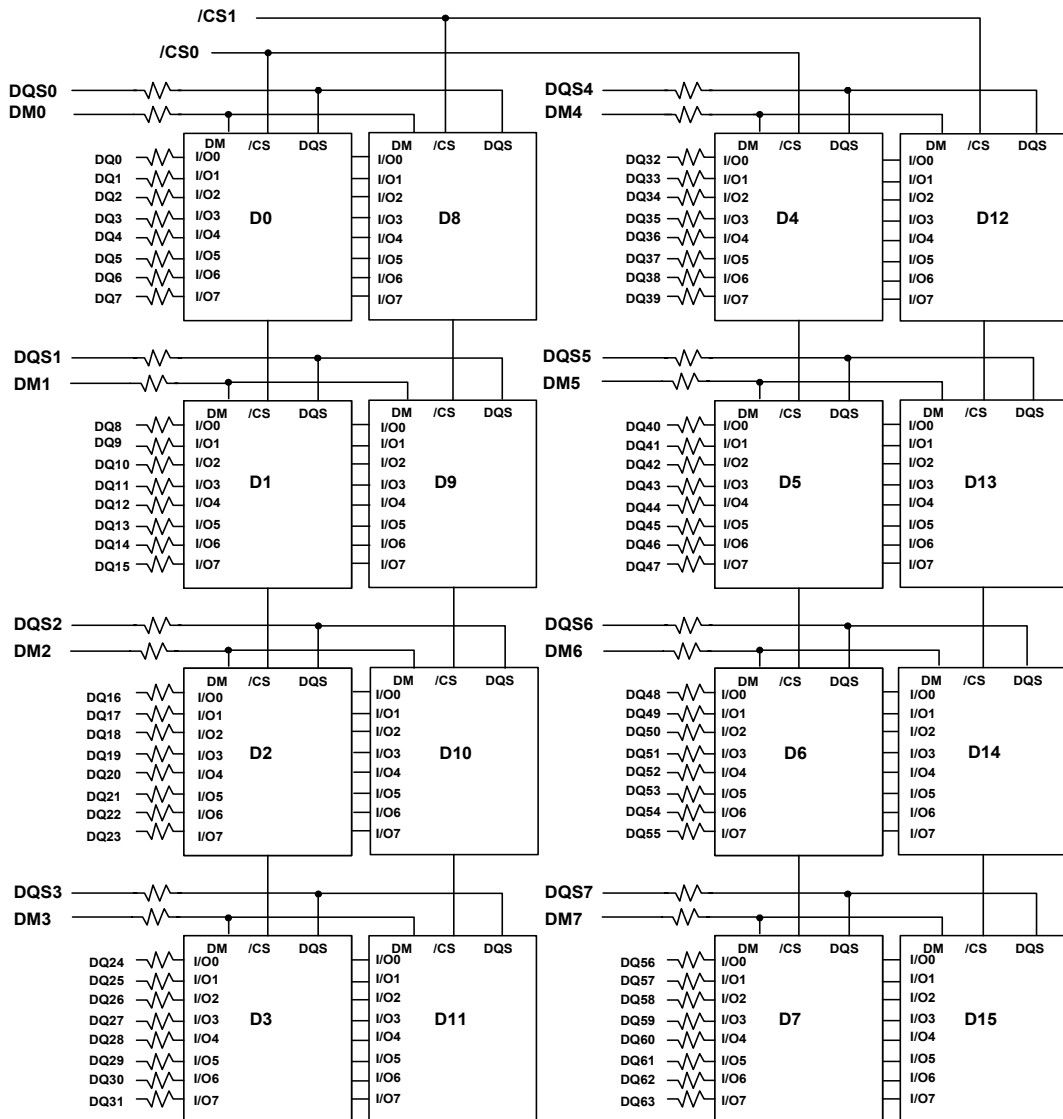

BA0-BA1	→	BA0-BA1 : SDRAMs D0-D15
A0-A12	→	A0-A12 : SDRAMs D0-D15
CKE1	→	CKE : SDRAMs D8-D15
/RAS	→	/RAS : SDRAMs D0-D15
/CAS	→	/CAS : SDRAMs D0-D15
CKE0	→	CKE : SDRAMs D0-D7
/WE	→	/WE : SDRAMs D0-D15

Note :

1. DQ-to-I/O wiring is shown as recommended but may be changed.
2. DQ/DQS/DM/CKE/S relationships must be maintained as shown.
3. DQ, DQS, DM/DQS resistors : 22 Ohms ± 5%.
4. VDDID strap connections (for memory device VDD, VDDQ) :
 STRAP OUT (OPEN) : VDD = VDDQ
 STRAP IN (VSS) : VDD ≠ VDDQ

ABSOLUTE MAXIMUM RATINGS

Parameter	Symbol	Rating	Unit
Operating Temperature (Ambient)	TA	0 ~ 70	°C
Storage Temperature	TSTG	-55 ~ 125	°C
Voltage on Any Pin relative to VSS	VIN, VOUT	-0.5 ~ 3.6	V
Voltage on VDD relative to VSS	VDD	-0.5 ~ 3.6	V
Voltage on VDDQ relative to VSS	VDDQ	-0.5 ~ 3.6	V
Output Short Circuit Current	IOS	50	mA
Power Dissipation	PD	1.0 x # of Components	W
Soldering Temperature & Time	TSOLDER	260 / 10	°C / Sec

Note : Operation at above absolute maximum rating can adversely affect device reliability

DC OPERATING CONDITIONS (TA= 0 to 70 °C, Voltage referenced to VSS= 0V)

Parameter	Symbol	Min	Typ.	Max	Unit	Note
Power Supply Voltage	VDD	2.3	2.5	2.7	V	
Power Supply Voltage	VDDQ	2.3	2.5	2.7	V	1
Input High Voltage	VIH	VREF + 0.15	-	VDDQ + 0.3	V	
Input Low Voltage	VIL	-0.3	-	VREF - 0.15	V	2
Termination Voltage	VTT	VREF - 0.04	VREF	VREF + 0.04	V	
Reference Voltage	VREF	1.15	1.25	1.35	V	3

Note :

1. VDDQ must not exceed the level of VDD.
2. VIL (min) is acceptable -1.5V AC pulse width with ≤ 5 ns of duration.
3. The value of VREF is approximately equal to 0.5VDDQ.

AC OPERATING CONDITIONS (TA= 0 to 70 °C, Voltage referenced to VSS= 0V)

Parameter	Symbol	Min	Max	Unit	Note
Input High (Logic 1) Voltage, DQ, DQS and DM signals	VIH(AC)	VREF + 0.31		V	
Input Low (Logic 0) Voltage, DQ, DQS and DM signals	VIL(AC)		VREF - 0.31	V	
Input Differential Voltage, CK and /CK inputs	VID(AC)	0.7	VDDQ + 0.6	V	1
Input Crossing Point Voltage, CK and /CK inputs	VIX(AC)	0.5*VDDQ-0.2	0.5*VDDQ+0.2	V	2

Note :

1. VID is the magnitude of the difference between the input level on CK and the input on /CK.
2. The value of VIX is expected to equal 0.5*V DDQ of the transmitting device and must track variations in the DC level of the same.

AC OPERATING TEST CONDITIONS (TA=0 to 70°C, Voltage referenced to VSS = 0V)

Parameter	Value	Unit
Reference Voltage	VDDQ x 0.5	V
Termination Voltage	VDDQ x 0.5	V
AC Input High Level Voltage (VIH, min)	VREF + 0.31	V
AC Input Low Level Voltage (VIL, max)	VREF - 0.31	V
Input Timing Measurement Reference Level Voltage	VREF	V
Output Timing Measurement Reference Level Voltage	VTT	V
Input Signal maximum peak swing	1.5	V
Input minimum Signal Slew Rate	1	V/ns
Termination Resistor (RT)	50	Ω
Series Resistor (RS)	25	Ω
Output Load Capacitance for Access Time Measurement (CL)	30	pF

CAPACITANCE (TA=25°C, f=100MHz)

Parameter	Pin	Symbol	Min	Max	Unit
Input Capacitance	A0 ~ A13, BA0, BA1	CIN1	50	68	pF
Input Capacitance	/RAS, /CAS, /WE	CIN2	50	68	pF
Input Capacitance	CKE0, CKE1	CIN3	36	48	pF
Input Capacitance	/CS0, /CS1	CIN4	36	48	pF
Input Capacitance	CK0, /CK0, CK1, /CK1	CIN5	30	38	pF
Input Capacitance	DM0 ~ DM7	CIN6	10	18	pF
Data Input / Output Capacitance	DQ0 ~ DQ63, DQS0 ~ DQS7	CIO1	10	18	pF

Note :

1. VDD = min. to max., VDDQ = 2.3V to 2.7V, VODC = VDDQ/2, VOpeak-to-peak = 0.2V
2. Pins not under test are tied to GND.
3. These values are guaranteed by design and are tested on a sample basis only.

OUTPUT LOAD CIRCUIT

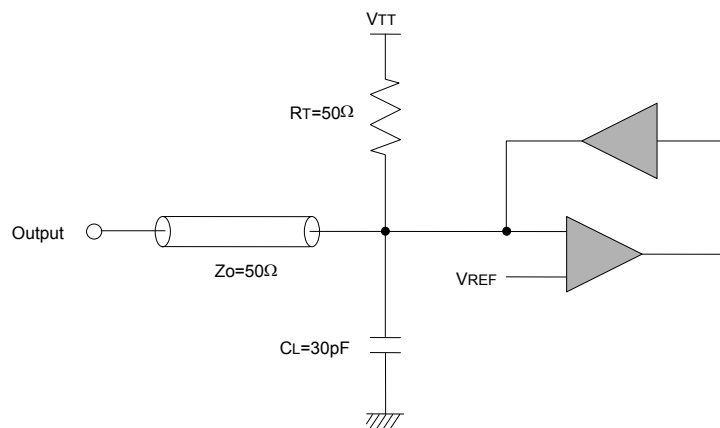

DC CHARACTERISTICS I (TA=0 to 70°C, Voltage referenced to VSS = 0V)

Parameter		Symbol	Min.	Max	Unit	Note
Input Leakage Current	Add, CMD, /CS, CKE	ILI	-32	32	uA	1
	CK0, /CK0, CK1, /CK1		-16	16		
Output Leakage Current		ILO	-5	5	uA	2
Output High Voltage		VOH	VTT + 0.76	-	V	IOH = -15.2mA
Output Low Voltage		VOL	-	VTT - 0.76	V	IOL = +15.2mA

Note :

1. VIN = 0 to 3.6V, All other pins are not tested under VIN = 0V
2. DOUT is disabled, VOUT=0 to 2.7V

DC CHARACTERISTICS II (TA=0 to 70°C, Voltage referenced to VSS = 0V)

Parameter	Symbol	Test Condition	Speed					Unit	Note	
			-J	-M	-K	-H	-L			
Operating Current	IDD0	One bank; Active - Precharge; tRC=tRC(min); tCK=tCK(min); DQ,DM and DQS inputs changing twice per clock cycle ; address and control inputs changing once per clock cycle	1400	1320	1240	1240	1080	mA		
Operating Current	IDD1	One bank; Active - Read - Precharge; Burst Length=2; tRC=tRC(min); tCK=tCK(min); address and control inputs changing once per clock cycle	1720	1560	1480	1480	1400	mA		
Precharge Power Down Standby Current	IDD2P	All banks idle; Power down - mode; CKE=Low, tCK=tCK(min)	160					mA		
Idle Standby Current	IDD2F	/CS=High, All banks idle; tCK=tCK(min); CKE= High; address and control inputs changing once per clock cycle. VIN=VREF for DQ, DQS and DM	560					mA		
Active Power Down Standby Current	IDD3P	One bank active; Power down mode; CKE=Low, tCK=tCK(min)	192					mA		
Active Standby Current	IDD3N	/CS=HIGH; CKE=HIGH; One bank; Active-Precharge; tRC=tRAS(max); tCK=tCK(min); DQ, DM and DQS inputs changing twice per clock cycle; Address and other control inputs changing once per clock cycle	640	600	600	600	600	mA		
Operating Current	IDD4R	Burst=2; Reads; Continuous burst; One bank active; Address and control inputs changing once per clock cycle; tCK=tCK(min); IOU=0mA	2280	1960	1960	1960	1720	mA		
Operating Current	IDD4W	Burst=2; Writes; Continuous burst; One bank active; Address and control inputs changing once per clock cycle; tCK=tCK(min); DQ, DM and DQS inputs changing twice per clock cycle	2280	1960	1960	1960	1720			
Auto Refresh Current	IDD5	tRC=tRFC(min) - 8*tCK for DDR200 at 100Mhz, 10*tCK for DDR266A & DDR266B at 133Mhz; distributed refresh	2520	2360	2360	2360	2200			
Self Refresh Current	IDD6	CKE=<0.2V; External clock on; tCK =tCK(min)	Normal	80					mA	
			Low Power	40					mA	
Operating Current - Four Bank Operation	IDD7	Four bank interleaving with BL=4 Refer to the following page for detailed test condition	3960	3320	3320	3320	2680	mA		

AC CHARACTERISTICS (AC operating conditions unless otherwise noted)

<DDR333, DDR266(2-2-2)>

Parameter	Symbol	DDR333		DDR266(2-2-2)		Unit	Note	
		Min	Max	Min	Max			
Row Cycle Time	tRC	60	-	60	-	ns		
Auto Refresh Row Cycle Time	trFC	72	-	75	-	ns		
Row Active Time	trAS	42	70K	45	120K	ns		
Active to Read with Auto Precharge Delay	trAP	18	-	15	-	ns	16	
Row Address to Column Address Delay	trCD	18	-	15	-	ns		
Row Active to Row Active Delay	trRD	12	-	15	-	ns		
Column Address to Column Address Delay	tCCD	1	-	1	-	CK		
Row Precharge Time	trP	18	-	15	-	ns		
Write Recovery Time	tWR	15	-	15	-	ns		
Write to Read Command Delay	twTR	1	-	1	-	CK		
Auto Precharge Write Recovery + Precharge Time	tdAL	(tWR/tCK) + (trP/tCK)	-	(tWR/tCK) + (trP/tCK)	-	CK	15	
System Clock Cycle Time	tCK	CL = 2.5	6	12	7.5	12	ns	
		CL = 2	7.5	12	7.5	12	ns	
Clock High Level Width	tCH	0.45	0.55	0.45	0.55	CK		
Clock Low Level Width	tCL	0.45	0.55	0.45	0.55	CK		
Data-Out edge to Clock edge Skew	tAC	-0.7	0.7	-0.75	0.75	ns		
DQS-Out edge to Clock edge Skew	tdQSCK	-0.6	0.6	-0.75	0.75	ns		
DQS-Out edge to Data-Out edge Skew	tdQSQ	-	0.4	-	0.5	ns		
Data-Out hold time from DQS	tQH	tHP -tQHS	-	tHP -tQHS	-	ns	1, 10	
Clock Half Period	tHP	min (tCL,tCH)	-	min (tCL,tCH)	-	ns	1,9	
Data Hold Skew Factor	tQHS	-	0.6	-	0.75	ns	10	
Valid Data Output Window	tdV	tQH-tdQSQ		tQH-tdQSQ		ns		
Data-out high-impedance window from CK, /CK	tHZ	-0.7	0.7	-0.75	0.75	ns	17	
Data-out low-impedance window from CK, /CK	tLZ	-0.7	0.7	-0.75	0.75	ns	17	
Input Setup Time (fast slew rate)	tIS	0.75	-	0.9	-	ns	2,3,5,6	
Input Hold Time (fast slew rate)	tIH	0.75	-	0.9	-	ns	2,3,5,6	
Input Setup Time (slow slew rate)	tIS	0.8	-	1.0	-	ns	2,4,5,6	
Input Hold Time (slow slew rate)	tIH	0.8	-	1.0	-	ns	2,4,5,6	
Input Pulse Width	tIPW	2.2		2.2		ns	6	
Write DQS High Level Width	tdQSH	0.35	-	0.35	-	CK		

AC CHARACTERISTICS (AC operating conditions unless otherwise noted)

- continued -

Parameter	Symbol	DDR333		DDR266(2-2-2)		Unit	Note
		Min	Max	Min	Max		
Write DQS Low Level Width	tDQSL	0.35	-	0.35	-	CK	
Clock to First Rising edge of DQS-In	tDQSS	0.75	1.25	0.72	1.28	CK	
Data-In Setup Time to DQS-In (DQ & DM)	tDS	0.45	-	0.5	-	ns	6,7, 11~13
Data-in Hold Time to DQS-In (DQ & DM)	tDH	0.45	-	0.5	-	ns	6,7, 11~13
DQ & DM Input Pulse Width	tDIPW	1.75	-	1.75	-	ns	
Read DQS Preamble Time	tRPRE	0.9	1.1	0.9	1.1	CK	
Read DQS Postamble Time	tRPST	0.4	0.6	0.4	0.6	CK	
Write DQS Preamble Setup Time	tWPRES	0	-	0	-	CK	
Write DQS Preamble Hold Time	tWPREH	0.25	-	0.25	-	CK	
Write DQS Postamble Time	tWPST	0.4	0.6	0.4	0.6	CK	
Mode Register Set Delay	tMRD	2	-	2	-	CK	
Exit Self Refresh to Any Execute Command	tXSC	200	-	200	-	CK	8
Average Periodic Refresh Interval	tREFI	-	7.8	-	7.8	us	

AC CHARACTERISTICS (AC operating conditions unless otherwise noted)

<DDR266A/B, DDR200>

Parameter	Symbol	DDR266A		DDR266B		DDR200		Unit	Note	
		Min	Max	Min	Max	Min	Max			
Row Cycle Time	tRC	65	-	65	-	70	-	ns		
Auto Refresh Row Cycle Time	tRFC	75	-	75	-	80	-	ns		
Row Active Time	tRAS	45	120K	45	120K	50	120k	ns		
Active to Read with Auto Precharge Delay	tRAP	20	-	20	-	20	-	ns	16	
Row Address to Column Address Delay	tRCD	20	-	20	-	20	-	ns		
Row Active to Row Active Delay	tRRD	15	-	15	-	15	-	ns		
Column Address to Column Address Delay	tCCD	1	-	1	-	1	-	CK		
Row Precharge Time	tRP	20	-	20	-	20	-	ns		
Write Recovery Time	tWR	15	-	15	-	15	-	ns		
Write to Read Command Delay	tWTR	1	-	1	-	1	-	CK		
Auto Precharge Write Recovery + Precharge Time	tDAL	(tWR/tCK) + (tRP/tCK)	-	(tWR/tCK) + (tRP/tCK)	-	(tWR/tCK) + (tRP/tCK)	-	CK	15	
System Clock Cycle Time	CL = 2.5	tCK	7.5	12	7.5	12	8.0	12	ns	
	CL = 2		7.5	12	10	12	10	12	ns	
Clock High Level Width	tCH	0.45	0.55	0.45	0.55	0.45	0.55	CK		
Clock Low Level Width	tCL	0.45	0.55	0.45	0.55	0.45	0.55	CK		
Data-Out edge to Clock edge Skew	tAC	-0.75	0.75	-0.75	0.75	-0.8	0.8	ns		
DQS-Out edge to Clock edge Skew	tDQSCK	-0.75	0.75	-0.75	0.75	-0.8	0.8	ns		
DQS-Out edge to Data-Out edge Skew	tDQSQ	-	0.5	-	0.5	-	0.6	ns		
Data-Out hold time from DQS	tQH	tHP -tQHS	-	tHP -tQHS	-	tHP -tQHS	-	ns	1, 10	
Clock Half Period	tHP	min (tCL,tCH)	-	min (tCL,tCH)	-	min (tCL,tCH)	-	ns	1,9	
Data Hold Skew Factor	tQHS	-	0.75	-	0.75	-	0.75	ns	10	
Valid Data Output Window	tDV	tQH-tDQSQ		tQH-tDQSQ		tQH-tDQSQ		ns		
Data-out high-impedance window from CK, /CK	tHZ	-0.75	0.75	-0.75	0.75	-0.8	0.8	ns	17	
Data-out low-impedance window from CK, /CK	tLZ	-0.75	0.75	-0.75	0.75	-0.8	0.8	ns	17	
Input Setup Time (fast slew rate)	tIS	0.9	-	0.9	-	1.1	-	ns	2,3,5,6	
Input Hold Time (fast slew rate)	tIH	0.9	-	0.9	-	1.1	-	ns	2,3,5,6	
Input Setup Time (slow slew rate)	tIS	1.0	-	1.0	-	1.1	-	ns	2,4,5,6	
Input Hold Time (slow slew rate)	tIH	1.0	-	1.0	-	1.1	-	ns	2,4,5,6	
Input Pulse Width	tIPW	2.2		2.2		2.5	-	ns	6	
Write DQS High Level Width	tDQSH	0.35	-	0.35	-	0.35	-	CK		

Parameter	Symbol	DDR266A		DDR266B		DDR200		Unit	Note
		Min	Max	Min	Max	Min	Max		
Write DQS Low Level Width	tDQSL	0.35	-	0.35	-	0.35	-	CK	
Clock to First Rising edge of DQS-In	tDQSS	0.75	1.25	0.75	1.25	0.72	1.28	CK	
Data-In Setup Time to DQS-In (DQ & DM)	tDS	0.45	-	0.45	-	0.5	-	ns	6,7, 11~13
Data-in Hold Time to DQS-In (DQ & DM)	tDH	0.45	-	0.45	-	0.5	-	ns	
DQ & DM Input Pulse Width	tDIPW	1.75	-	1.75	-	1.75	-	ns	
Read DQS Preamble Time	tRPRE	0.9	1.1	0.9	1.1	0.9	1.1	CK	
Read DQS Postamble Time	tRPST	0.4	0.6	0.4	0.6	0.4	0.6	CK	
Write DQS Preamble Setup Time	tWPRES	0	-	0	-	0	-	CK	
Write DQS Preamble Hold Time	tWPREH	0.25	-	0.25	-	0.25	-	CK	
Write DQS Postamble Time	tWPST	0.4	0.6	0.4	0.6	0.4	0.6	CK	
Mode Register Set Delay	tMRD	2	-	2	-	2	-	CK	
Exit Self Refresh to Any Execute Command	tXSC	200	-	200	-	200	-	CK	8
Average Periodic Refresh Interval	tREFI	-	7.8	-	7.8	-	7.8	us	

Note :

1. This calculation accounts for tDQSQ(max), the pulse width distortion of on-chip circuit and jitter.
2. Data sampled at the rising edges of the clock : A0~A12, BA0~BA1, CKE, /CS, /RAS, /CAS, /WE.
3. For command/address input slew rate $\geq 1.0V/ns$
4. For command/address input slew rate $\geq 0.5V/ns$ and $< 1.0V/ns$
This derating table is used to increase tIS/tIH in case where the input slew-rate is below 0.5V/ns.
Input Setup / Hold Slew-rate Derating Table.

Input Setup / Hold Slew-rate	Delta tIS	Delta tIH
V/ns	ps	ps
0.5	0	0
0.4	+50	0
0.3	+100	0

5. CK, /CK slew rates are $\geq 1.0V/ns$
6. These parameters guarantee device timing, but they are not necessarily tested on each device, and they may be guaranteed by design or tester correlation.
7. Data latched at both rising and falling edges of Data Strobes(LDQS/UDQS) : DQ, LDM/UDM.
8. Minimum of 200 cycles of stable input clocks after Self Refresh Exit command, where CKE is held high, is required to complete Self Refresh Exit and lock the internal DLL circuit of DDR SDRAM.
9. Min (tCL, tCH) refers to the smaller of the actual clock low time and the actual clock high time as provided to the device (i.e. this value can be greater than the minimum specification limits for tCL and tCH).
10. tHP = minimum half clock period for any given cycle and is defined by clock high or clock low (tCH, tCL). tQHS consists of tDQSQmax, the pulse width distortion of on-chip clock circuits, data pin to pin skew and output pattern effects and p-channel to n-channel variation of the output drivers.
11. This derating table is used to increase tDS/tDH in case where the input slew-rate is below 0.5V/ns.
Input Setup / Hold Slew-rate Derating Table.

Input Setup / Hold Slew-rate	Delta tDS	Delta tDH
V/ns	ps	ps
0.5	0	0
0.4	+75	+75
0.3	+150	+150

12. I/O Setup/Hold Plateau Derating. This derating table is used to increase tDS/tDH in case where the input level is flat below VREF +/-310mV for a duration of up to 2ns.

I/O Input Level	Delta tDS	Delta tDH
mV	ps	ps
+280	+50	+50

13. I/O Setup/Hold Delta Inverse Slew Rate Derating. This derating table is used to increase tDS/tDH in case where the DQ and DQS slew rates differ. The Delta Inverse Slew Rate is calculated as $(1/SlewRate1)-(1/SlewRate2)$. For example, if slew rate 1=0.5V/ns and Slew Rate2 = 0.4V/n then the Delta Inverse Slew Rate = -0.5ns/V.

(1/SlewRate1)-(1/SlewRate2)	Delta tDS	Delta tDH
ns/V	ps	ps
0	0	0
+/-0.25	+50	+50
+/- 0.5	+100	+100

14. DQS, DM and DQ input slew rate is specified to prevent double clocking of data and preserve setup and hold times. Signal transitions through the DC region must be monotonic.
15. $tDAL = (tDPL / tCK) + (tRP / tCK)$. For each of the terms above, if not already an integer, round to the next highest integer. tCK is equal to the actual system clock cycle time.
 Example: For DDR266B at CL=2.5 and tCK = 7.5 ns,
 $tDAL = (15 \text{ ns} / 7.5 \text{ ns}) + (20 \text{ ns} / 7.5 \text{ ns}) = (2.00) + (2.67)$
 Round up each non-integer to the next highest integer: = (2) + (3), tDAL = 5 clock
16. For the parts which do not have internal RAS lockout circuit, Active to Read with Auto precharge delay should be $tRAS - BL/2 \times tCK$.
17. tHZ and tLZ transitions occur in the same access time windows as valid data transitions. These parameters are not referenced to a specific voltage level but specify when the device output is no longer driving (HZ), or begins driving (LZ).

SIMPLIFIED COMMAND TRUTH TABLE

Command	CKEn-1	CKEn	/CS	/RAS	/CAS	/WE	ADDR	A10/AP	BA	Note
Extended Mode Register Set	H	X	L	L	L	L	OP code			1,2
Mode Register Set	H	X	L	L	L	L	OP code			1,2
Device Deselect	H	X	H	X	X	X	X			1
No Operation			L	H	H	H				
Bank Active	H	X	L	L	H	H	RA		V	1
Read	H	X	L	H	L	H	CA	L	V	1
Read with Autoprecharge								H		1,3
Write	H	X	L	H	L	L	CA	L	V	1
Write with Autoprecharge								H		1,4
Precharge All Banks	H	X	L	L	H	L	X	H	X	1,5
Precharge selected Bank								L	V	1
Read Burst Stop	H	X	L	H	H	L	X			1
Auto Refresh	H	H	L	L	L	H	X			1
Self Refresh	Entry	H	L	L	L	L	H	X		1
	Exit	L	H	H	X	X	X			1
Precharge Power Down Mode	Entry			H	L	H	X	X	X	X
		L	H			H	H	1		
	Exit	L	H	H	X	X	X	1		
				L	H	H	H	1		
Active Power Down Mode (Clock Suspend)	Entry	H	L	H	X	X	X	X		1
				L	V	V	V			1
	Exit	L	H	X						1

(H=Logic High Level, L=Logic Low Level, X=Don't Care, V=Valid Data Input, OP Code=Operand Code, NOP=No Operation)

Note :

- LDM/UDM states are Don't Care. Refer to below Write Mask Truth Table.
- OP Code(Operand Code) consists of A0~A12 and BA0~BA1 used for Mode Registering during Extended MRS or MRS.
Before entering Mode Register Set mode, all banks must be in a precharge state and MRS command can be issued after tRP period from Prechagre command.
- If a Read with Autoprecharge command is detected by memory component in CK(n), then there will be no command presented to activated bank until CK(n+BL/2+tRP).
- If a Write with Autoprecharge command is detected by memory component in CK(n), then there will be no command presented to activated bank until CK(n+BL/2+1+tdPL+tRP). Last Data-In to Prechage delay(tdPL) which is also called Write Recovery Time (tWR) is needed to guarantee that the last data has been completely written.
- If A10/AP is High when Row Precharge command being issued, BA0/BA1 are ignored and all banks are selected to be precharged.

PACKAGE DIMENSIONS

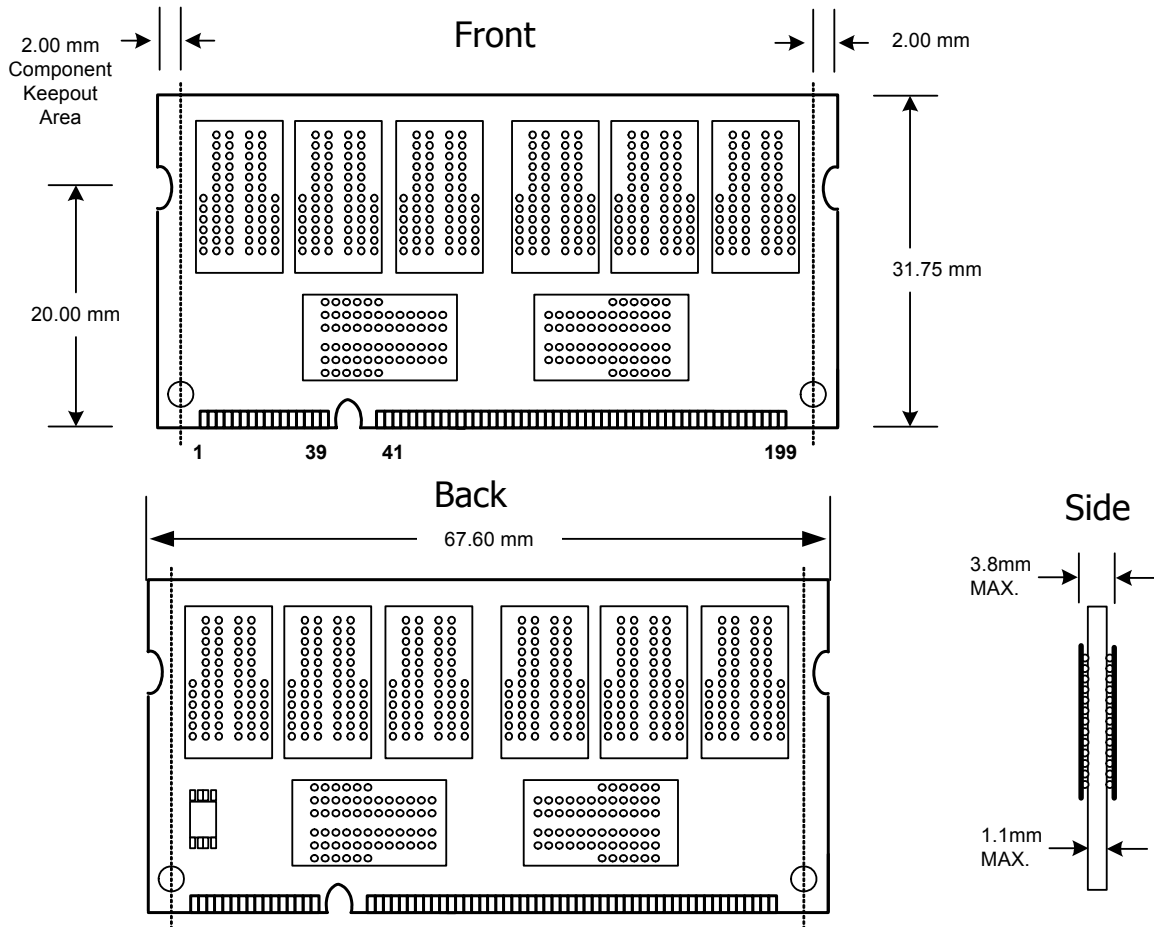

SPD SPECIFICATION
(128Mx64 Unbuffered DDR SO-DIMM)

SERIAL PRESENCE DETECT

 Bin Sort :J(DDR333),M(DDR266(2-2-2)),K(DDR266A@CL=2)
 H(DDR266B@CL=2.5),L(DDR200@CL=2)

Byte#	Function Description	Function Supported					Hexa Value					Note
		J	M	K	H	L	J	M	K	H	L	
0	Number of Bytes written into serial memory at module manufacturer	128 Bytes					80h					
1	Total number of Bytes in SPD device	256 Bytes					08h					
2	Fundamental memory type	DDR SDRAM					07h					
3	Number of row address on this assembly	13					0Dh					1
4	Number of column address on this assembly	11					0Bh					1
5	Number of physical banks on DIMM	2Bank					02h					
6	Module data width	64 Bits					40h					
7	Module data width (continued)	-					00h					
8	Module voltage Interface levels(VDDQ)	SSTL 2.5V					04h					
9	DDR SDRAM cycle time at CAS Latency=2.5(tCK)	6.0ns	7.5ns	7.5ns	7.5ns	8.0ns	60h	75h	75h	75h	80h	2
10	DDR SDRAM access time from clock at CL=2.5 (tAC)	+/-0.7ns	+/-0.75ns			+/-0.8ns	70h	75h	75h	75h	80h	2
11	Module configuration type	Non-ECC					00h					
12	Refresh rate and type	7.8us & Self refresh					82h					
13	Primary DDR SDRAM width	x8					08h					
14	Error checking DDR SDRAM data width	N/A					00h					
15	Minimum clock delay for back-to-back random column address(tCCD)	1 CLK					01h					
16	Burst lengths supported	2,4,8					0Eh					
17	Number of banks on each DDR SDRAM	4 Banks					04h					
18	CAS latency supported	2, 2.5					0Ch					
19	CS latency	0					01h					
20	WE latency	1					02h					
21	DDR SDRAM module attributes	Differential Clock Input					20h					
22	DDR SDRAM device attributes : General	+/-0.2Voltage tolerance, Concurrent Auto Precharge tRAS Lock Out					C0h					
23	DDR SDRAM cycle time at CL=2.0(tCK)	7.5ns	7.5ns	7.5ns	10ns	10ns	75h	75h	75h	A0h	A0h	2
24	DDR SDRAM access time from clock at CL=2.0(tAC)	+/-0.7ns	+/-0.75ns			+/-0.8ns	70h	75h	75h	75h	80h	2
25	DDR SDRAM cycle time at CL=1.5(tCK)	-					00h					2
26	DDR SDRAM access time from clock at CL=1.5(tAC)	-					00h					2
27	Minimum row precharge time(tRP)	18ns	15ns	20ns	20ns	20ns	48h	3Ch	50h	50h	50h	
28	Minimum row activate to row active delay(tRRD)	12ns	15ns	15ns	15ns	15ns	30h	3Ch	3Ch	3Ch	3Ch	
29	Minimum RAS to CAS delay(tRCD)	18ns	15ns	20ns	20ns	20ns	48h	3Ch	50h	50h	50h	
30	Minimum active to precharge time(tRAS)	42ns	45ns	45ns	45ns	50ns	2Ah	2Dh	2Dh	2Dh	32h	
31	Module row density	512MB					80h					
32	Command and address signal input setup time(tIS)	0.75ns	0.9ns	0.9ns	0.9ns	1.1ns	75h	90h	90h	90h	80h	
33	Command and address signal input hold time(tIH)	0.75ns	0.9ns	0.9ns	0.9ns	1.1ns	75h	90h	90h	90h	80h	
34	Data signal input setup time(tDS)	0.45ns	0.5ns	0.5ns	0.5ns	0.6ns	45h	50h	50h	50h	60h	
35	Data signal input hold time(tDH)	0.45ns	0.5ns	0.5ns	0.5ns	0.6ns	45h	50h	50h	50h	60h	
36~40	Reserved for VCSDRAM	Undefined					00h					
41	Minimum active / auto-refresh time (tRC)	60ns	60ns	65ns	65ns	70ns	3Ch	3Ch	41h	41h	46h	
42	Minimum auto-refresh to active/auto-refresh command period(tRFC)	72ns	75ns	75ns	75ns	80ns	48h	4Bh	4Bh	4Bh	50h	
43	Maximum cycle time (tCK max)	12ns	12ns	12ns	12ns	12ns	30h	30h	30h	30h	30h	
44	Maximum DQS-DQ skew time(tDQSQ)	0.40ns	0.5ns	0.5ns	0.5ns	0.6ns	28h	32h	32h	32h	3Ch	
45	Maximum read data hold skew factor(tQHS)	0.50ns	0.75ns	0.75ns	0.75ns	0.75ns	50h	75h	75h	75h	75h	
46~61	Superset information(may be used in future)	Undefined					00h					
62	SPD Revision code	Initial release					00h					
63	Checksum for Bytes 0~62	-					38h	CCh	F9h	24h	BEh	

SERIAL PRESENCE DETECT
- continued -

Byte #	Function Description	Function Supported					Hexa Value					Note
		J	M	K	H	L	J	M	K	H	L	
64	Manufacturer JEDEC ID Code	Hynix JEDEC ID					ADh					
65~71	----- Manufacturer JEDEC ID Code	-					00h					
72	Manufacturing location	Hynix(Korea Area) HSA(United States Area) HSE(Europe Area) HSJ(Japan Area) Singapore Asia Area					0*h 1*h 2*h 3*h 4*h 5*h					6
73	Manufacture part number(Hynix Memory Module)	H					48h					
74	----- Manufacture part number(Hynix Memory Module)	Y					59h					
75	----- Manufacture part number(Hynix Memory Module)	M					4Dh					
76	Manufacture part number (DDR SDRAM)	D					44h					
77	Manufacture part number(Memory density)	5					35h					
78	Manufacture part number(Module Depth)	1					32h					
79	----- Manufacture part number(Module Depth)	2					32h					
80	Manufacture part number(Module type)	M					4Dh					
81	Manufacture part number(Data width)	6					36h					
82	-----Manufacture part number(Data width)	4					34h					
83	Manufacture part number(Refresh, # of Bank.)	6(8K refresh,4Bank)					36h					
84	Manufacture part number(Component Generation)	B					42h					
85	Manufacture part number(Component Package Type)	F					46h					
86	Manufacture part number(Component configuration)	8					38h					
87	Manufacture part number(Hyphen)	-					2Dh					
88	Manufacture part number(Minimum cycle time)	J	M	K	H	L	4Ah	4Dh	4Bh	48h	4Ch	
89	Manufacture part number(T.B.D)	Blank					20h					
90	Manufacture revision code(for Component)	-					-					
91	Manufacture revision code (for PCB)	-					-					
92	Manufacturing date(Year)	-					-					3
93	Manufacturing date(Week)	-					-					3
94~98	Module serial number	-					-					4
99~127	Manufacturer specific data (may be used in future)	Undefined					00h					5
128~255	Open for customer use	Undefined					00h					5

Note :

1. The bank address is excluded
2. These value is based on the component specification
3. These bytes are programmed by code of date week & date year
4. These bytes apply to Hynix's own Module Serial Number system
5. These bytes undefined and coded as '00h'
6. Refer to Hynix web site

Byte 85~86, Low power part

Byte #	Function Description	Function Supported					Hexa Value					Note
		J	M	K	H	L	J	M	K	H	L	
85	Manufacture part number(Low power part)	L					4Ch					
86	Manufacture part number(Component configuration)	F					46h					
87	Manufacture part number(Hyphen)	8					38h					