



SCHOTTKY BARRIER RECTIFIER

SR1620 THRU SR16100

VOLTAGE RANGE

20 to 100 Volts

CURRENT

16.0 Amperes

FEATURES

- Metal of silicon rectifier, majority carrier conduction
- Guard ring for transient protection
- Low power loss, high efficiency
- High current capability low VF
- High surge capacity
- Plastic package has UL flammability classification
- 94V-O
- For use in low voltage, high frequency inverters. Free wheeling, and polarity protection applications

MECHANICAL DATA

- Case: TO-220AC molded plastic
- Polarity: as marked on the body
- Weight: 0.08ounce, 2.24 grams
- Mounting position: Any

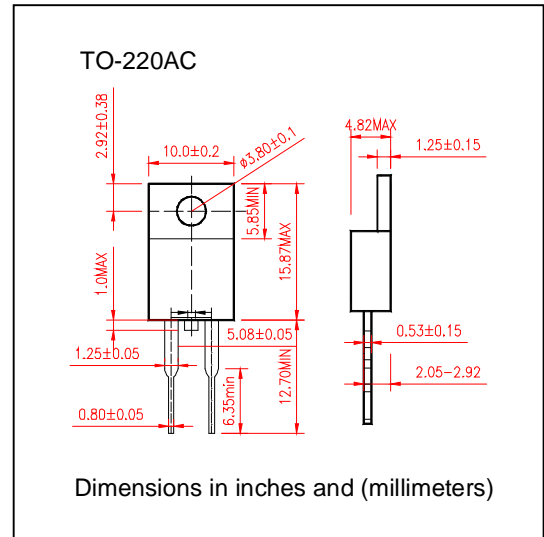

MAXIMUM RATINGS AND ELECTRICAL CHARACTERISTICS

- Ratings at 25°C ambient temperature unless otherwise specified
- Single Phase, half wave, 60Hz, resistive or inductive load
- For capacitive load derate current by 20%

	SYMBOLS	SR 1620	SR 1630	SR 1635	SR 1640	SR 1645	SR 1650	SR 1660	SR 1680	SR 16100	SR 16150	SR 16200	UNIT
Maximum Repetitive Peak Reverse Voltage	V_{RRM}	20	30	35	40	45	50	60	80	100	150	200	Volts
Maximum RMS Voltage	V_{RMS}	14	21	25	28	32	35	42	56	70	105	140	Volts
Maximum DC Blocking Voltage	V_{DC}	20	30	35	40	45	50	60	80	100	150	200	Volts
Maximum Average Forward Rectified Current @ $T_c=100^\circ\text{C}$	$I_{(AV)}$	16.0											Amps
Peak Forward Surge Current 8.3ms single half sine wave superimposed on rated load (JEDEC method)	I_{FSM}	150											Amps
Maximum Forward Voltage 25°C (NOTE1) $I_F=16A$ @ $T_J=25^\circ\text{C}$	V_F	0.65				0.75			0.85				Volts
Maximum DC Reverse Current at rated DC Blocking Voltage	$T_c = 25^\circ\text{C}$	0.5											mA
	$T_c = 100^\circ\text{C}$	100											
Typical Thermal Resistance (Note 2)	C_J	500											pF
Typical Junction Capacitance (Note 3)	R_{0JC}	2.0											°C/W
Operating and Storage Temperature Range	T_J T_{STG}	(-55 to +150)											°C

Notes:

1. Thermal Resistance Junction to Case
2. 300 μ s Pulse width, 2% duty cycle



SCHOTTKY BARRIER RECTIFIER

SR1620 THRU SR16100

VOLTAGE RANGE 20 to 100 Volts
CURRENT 16.0 Ampere

RATING AND CHARACTERISTIC CURVES SR1620 THRU SR16100

