

Sitronix

ST7063C

80CH Segment Driver for Dot Matrix LCD

■ Functions

- Dot matrix LCD driver with two 40 channel outputs
- Bias voltage (V1 ~ V4)
- input/output signals
 - Input : Serial display data and control pulse from controller IC
 - Output : 40 X 2 channels waveform for LCD driving

■ Features

- Display driving bias : static to 1/5
- Power supply for logic : 2.7V ~ 5.5V
- Power supply for LCD voltage ($V_{DD} \sim V_{EE}$) : 3V ~ 11V

100 Pin QFP package and bare chip available

■ Description

ST7063C is a segment driver for dot matrix type LCD display. It features 80 channels with 40 X 2 bits bi-directional shift registers, data latches, LCD drivers and logic control circuits. It is fabricated by high voltage CMOS process with low current consumption.

The **ST7063C** can convert serial data received from an LCD controller, such as **ST7066U**, into parallel data and send out LCD driving

waveforms to the LCD panel. The **ST7063C** is designed for general purpose LCD drivers. It can drive both static and dynamic drive LCD. The LSI can be used as segment driver.

The **ST7063C** has pin function compatibility with the KS0063(B) that allows the user to easily replace it with an **ST7063C**.

ST7063C Specification Revision History		
Version	Date	Description
1.1	2000/07/31	First Edition
1.2	2000/11/14	Added QFP Pad Configuration(Page 6)
1.2a	2001/02/26	Changed Application Circuit(Page 11)
1.3	2001/05/04	1. ST7063 Transition to ST7063C 2. Moved QFP Package Dimensions Page 12 to Page 5
1.3a	2001/08/29	Added “Substrate connect to VDD”(Page 4)
1.3b	2005/11/08	Update temperature range

■ Functional Block Diagram

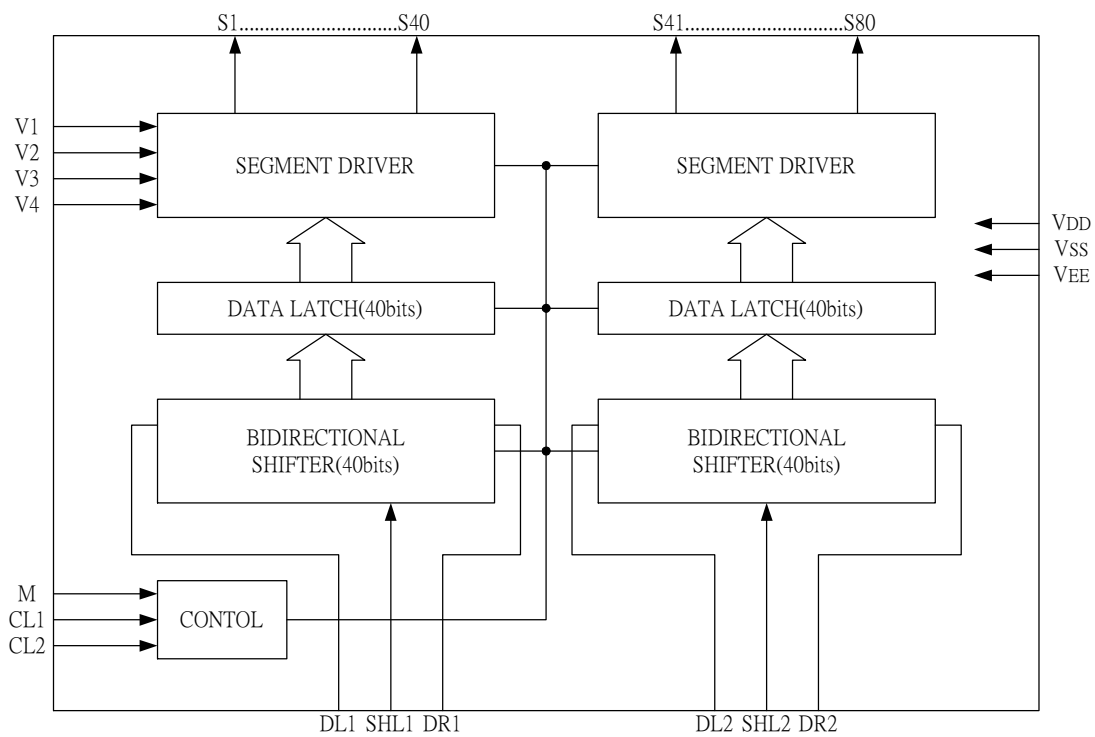

■ Pad Arrangement

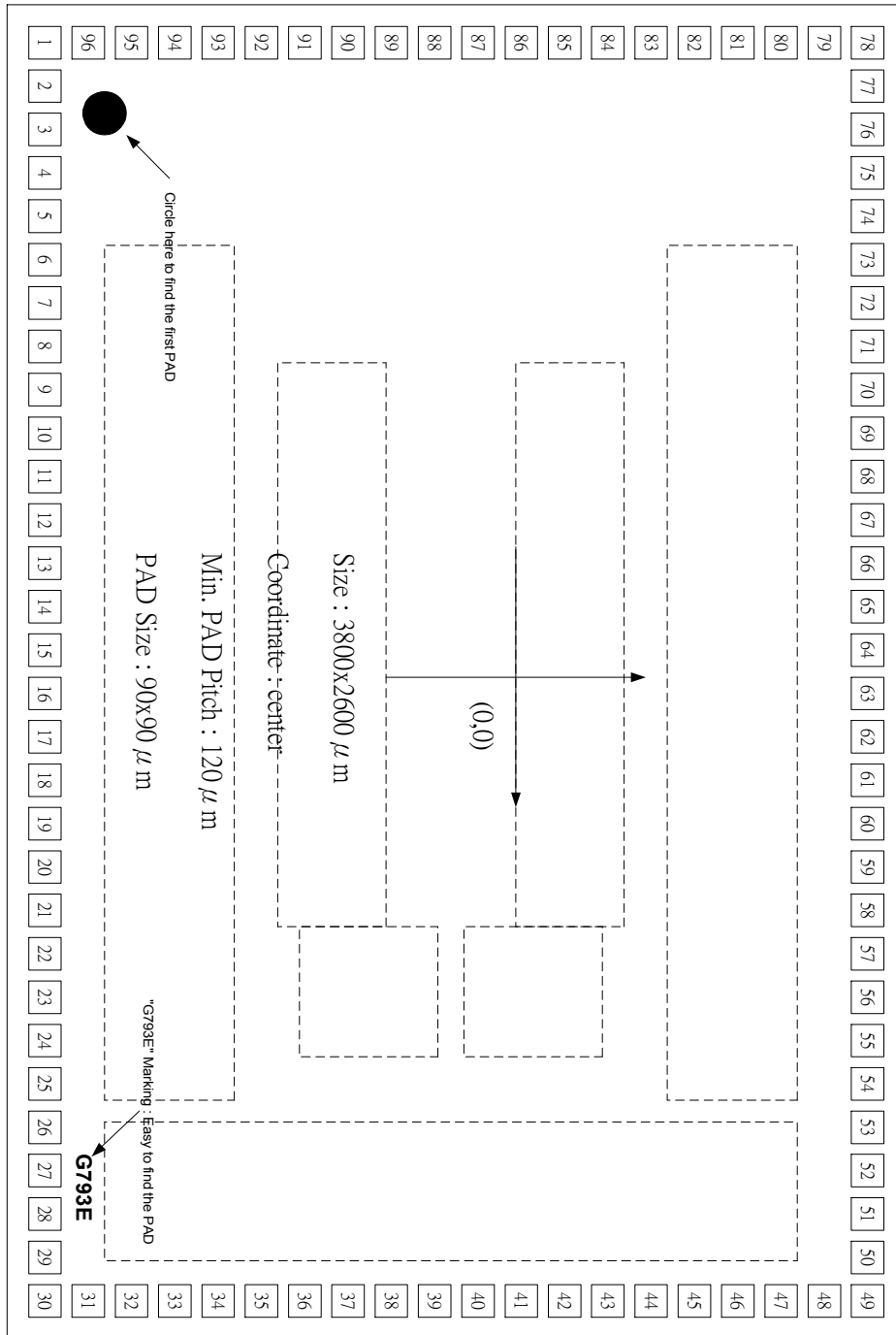

Substrate connect to VDD.

■ Package Dimensions

100-QFP-1420C

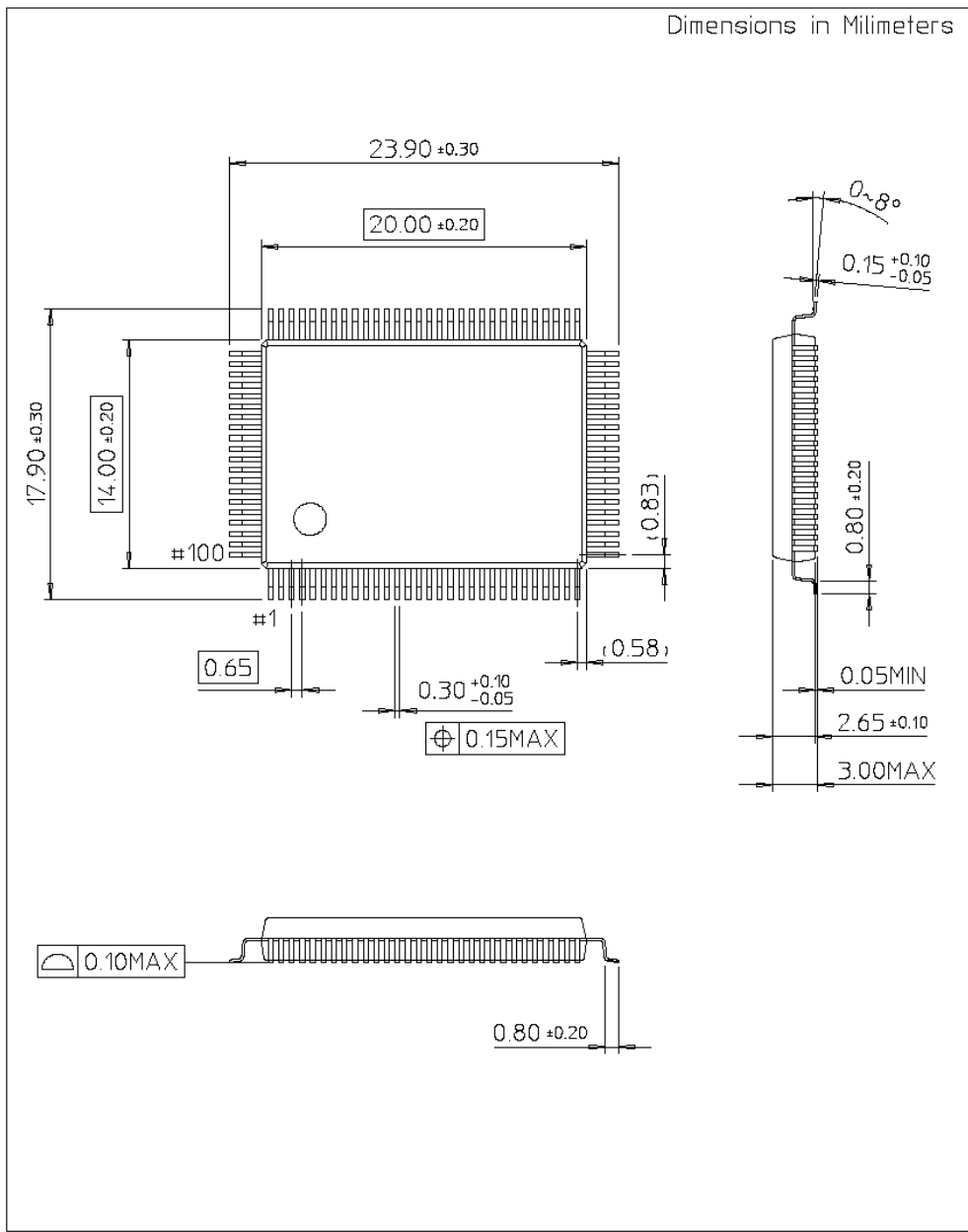

Pin Configuration(QFP 100)

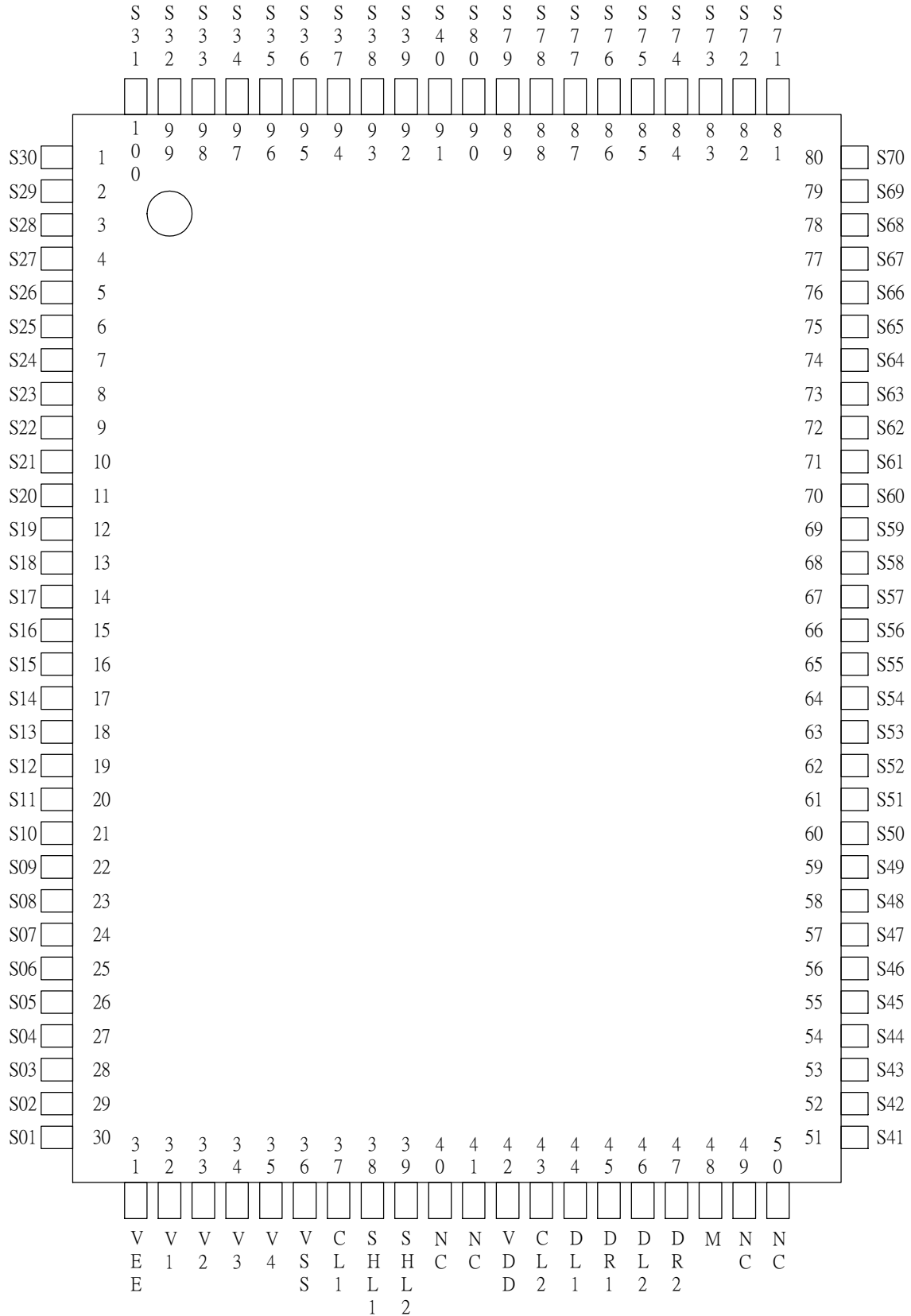

■ Pad Name and Coordinates

Pad No.	Pad Name	X	Y	Pad No.	Pad Name	X	Y	Pad No.	Pad Name	X	Y
1	S42	-1760	-1160	33	S74	1760	-780	65	S15	-180	1160
2	S43	-1630	-1160	34	S75	1760	-660	66	S14	-300	1160
3	S44	-1500	-1160	35	S76	1760	-540	67	S13	-420	1160
4	S45	-1380	-1160	36	S77	1760	-420	68	S12	-540	1160
5	S46	-1260	-1160	37	S78	1760	-300	69	S11	-660	1160
6	S47	-1140	-1160	38	S79	1760	-180	70	S10	-780	1160
7	S48	-1020	-1160	39	S80	1760	-60	71	S9	-900	1160
8	S49	-900	-1160	40	S40	1760	60	72	S8	-1020	1160
9	S50	-780	-1160	41	S39	1760	180	73	S7	-1140	1160
10	S51	-660	-1160	42	S38	1760	300	74	S6	-1260	1160
11	S52	-540	-1160	43	S37	1760	420	75	S5	-1380	1160
12	S53	-420	-1160	44	S36	1760	540	76	S4	-1500	1160
13	S54	-300	-1160	45	S35	1760	660	77	S3	-1630	1160
14	S55	-180	-1160	46	S34	1760	780	78	S2	-1760	1160
15	S56	-60	-1160	47	S33	1760	900	79	S1	-1760	1030
16	S57	60	-1160	48	S32	1760	1030	80	VEE	-1760	900
17	S58	180	-1160	49	S31	1760	1160	81	V1	-1760	780
18	S59	300	-1160	50	S30	1630	1160	82	V2	-1760	660
19	S60	420	-1160	51	S29	1500	1160	83	V3	-1760	540
20	S61	540	-1160	52	S28	1380	1160	84	V4	-1760	420
21	S62	660	-1160	53	S27	1260	1160	85	VSS	-1760	300
22	S63	780	-1160	54	S26	1140	1160	86	CL1	-1760	180
23	S64	900	-1160	55	S25	1020	1160	87	SHL1	-1760	60
24	S65	1020	-1160	56	S24	900	1160	88	SHL2	-1760	-60
25	S66	1140	-1160	57	S23	780	1160	89	VDD	-1760	-180
26	S67	1260	-1160	58	S22	660	1160	90	CL2	-1760	-300
27	S68	1380	-1160	59	S21	540	1160	91	DL1	-1760	-420
28	S69	1500	-1160	60	S20	420	1160	92	DR1	-1760	-540
29	S70	1630	-1160	61	S19	300	1160	93	DL2	-1760	-660
30	S71	1760	-1160	62	S18	180	1160	94	DR2	-1760	-780
31	S72	1760	-1030	63	S17	60	1160	95	M	-1760	-900
32	S73	1760	-900	64	S16	-60	1160	96	S41	-1760	-1030

■ Pin Description

Pin Name	Purpose	Description	I/O
VDD	POWER	for logic	N/A
VSS	GROUND	for logic	N/A
VEE	LCD GND	for LCD driving voltage	N/A
V1 V2	LCD output	used as select voltage level	I
V3 V4	LCD output	used as non select voltage level	I
S1-S40	segment	LCD driver output for part 1	O
SHL1	direction	direction control for part 1 segments	I
DL1, DR1	data in /out	If SHL1 = 1 then DL1=out, DR1=in If SHL1 = 0 then DL1=in, DR1=out	I/O
S41-S80	segment	LCD driver output for part 2	O
SHL2	direction	direction control for part 2 segments	I
DL2, DR2	data in/out	If SHL2 = 1 then DL2=out, DR2=in If SHL2 = 0 then DL2=in, DR2=out	I/O
M	alternation	Alternate the LCD driving waveform	I
CL1	latch clock	latch the data after shift is completed	I
CL2	shift clock	shift the data into the segments	I

■ Functional Description

Clock

The CL1 is the clock to latch data on the falling edge. It latches the data input from the bi-directional shift register at the falling edge of CL1 and transfers its outputs to the LCD driver circuit. The CL2 is the clock to shift data on the falling edge. It shifts the serial data at the falling of CL2 and transfers the output of each bit of the register to the latch circuit.

Shift Registers And Data I/O

The **ST7063C** supplies two sets of 40-bit shift register, which controls the shift direction by SHL1 & SHL2. The SHL1 controls the 1st 40-bit shift register, and SHL2 controls the 2nd 40-bit shift register. When SHL1 is connected to VDD, the 1st shift direction is from S40 to S1; when SHL1 is connected to VSS, the shift direction changes from S1 to S40. When SHL2 is connected to VDD, the 2nd shift direction is from S80 to S41; when SHL2 is connected to VSS, the shift direction changes from S41 to S80.

The DL1, DR1, DL2, DR2 are data input or output option function.

Shift Direction of Channel 1			
SHL1	Shift Direction	DL1	DR1
0	S1 → S40	IN	OUT
1	S40 → S1	OUT	IN

Shift Direction of Channel 2			
SHL2	Shift Direction	DL2	DR2
0	S41 → S80	IN	OUT
1	S80 → S41	OUT	IN

■ LCD Output Waveforms

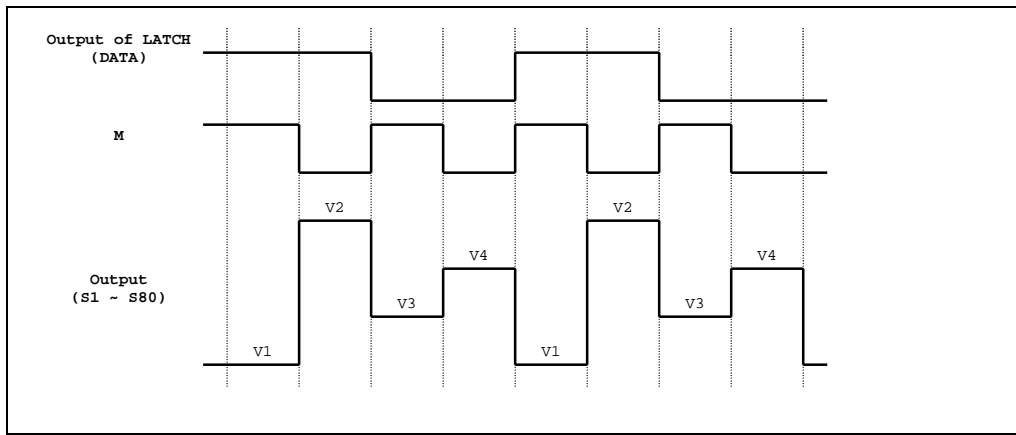

■ Timing Characteristics

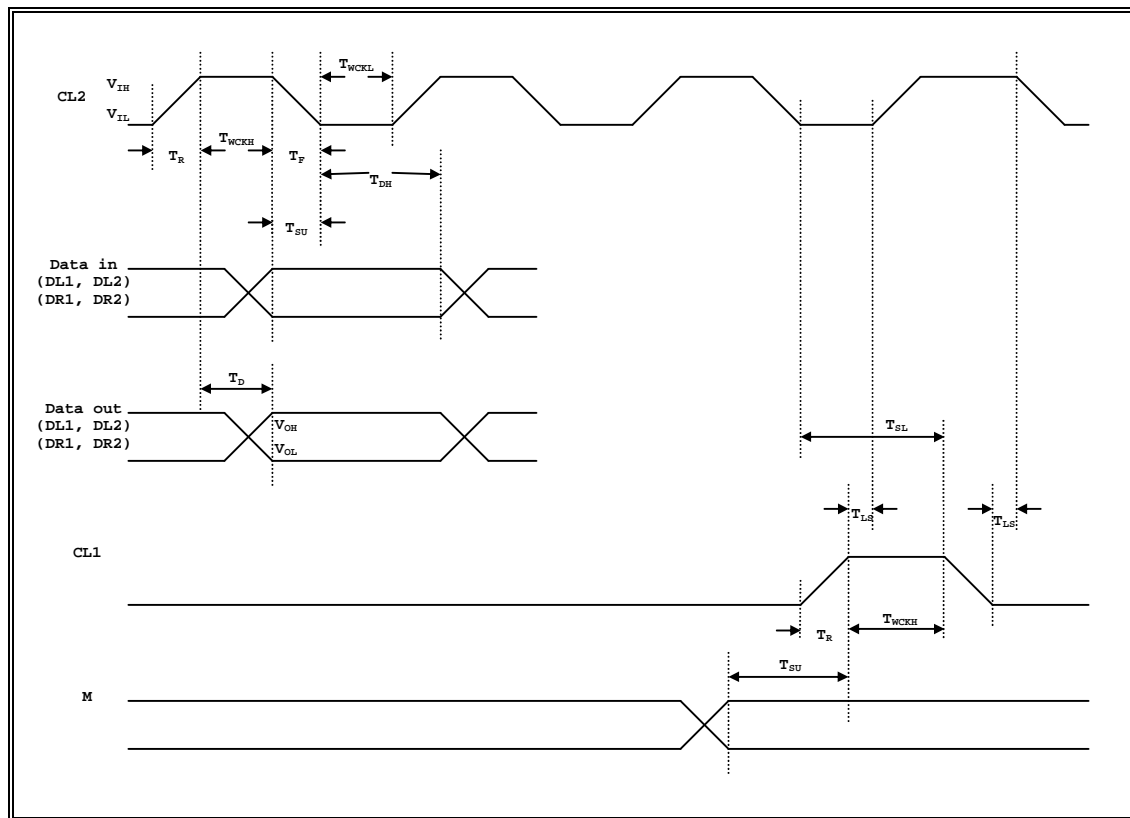

■ D.C Characteristics

Symbol	Parameter	Test Condition	Min.	Typ.	Max.	Unit	Applicable pin
VDD	Operating Voltage	-	2.7	-	5.5	V	-
VLCD	Driver Supply Voltage	VDD-VEE	3	-	11	V	-
VIH	Input High Voltage	-	0.7 VDD	-	VDD	V	CL1,CL2,M,SHL1,SHL 2 DL1,DL2,DR1,DR2
VIL	Input Low Voltage	-	0	-	0.3 VDD	V	
ILKG	Input Leakage Current	VIN =0 ~ VDD	-5	-	5	uA	
VOH	Output High Voltage	IOH = -0.4mA	VDD -0.4	-	-	V	DL1,DL2,DR1,DR2 V1~V4, S1~S80
VOL	Output Low Voltage	IOL = +0.4mA	-	-	0.4	V	
IDD	Operating Current	FCL2 = 400KHZ	-	100	300	uA	VDD,VEE
IV	Leakage Current	VIN =VDD ~ VEE	-10	-	10	uA	V1 ~ V4

■ A.C Characteristics

Symbol	Parameter	Test Condition	Min.	Max.	Unit	Applicable pin
FCL	Data Shift Frequency	-	-	400	KHZ	CL2
TWCKH	Clock High Level Width	-	800	-	ns	CL1,CL2
TWCKL	Clock Low Level Width	-	800	-	ns	CL2
TSL	Clock Set-up Time	CL2 → CL1	500	-	ns	CL1,CL2
TLS	Clock Set-up Time	CL1 → CL2	500	-	ns	CL1,CL2
TR/TF	Clock Rise/Fall Time	-	-	200	ns	CL1,CL2
TSU	Data Set-up Time	-	300	-	ns	DL1,DL2,DR1,DR2
TDH	Data Hold Time	-	300	-	ns	DL1,DL2,DR1,DR2
TD	Data Delay Time	CL = 15 PF	-	500	ns	DL1,DL2,DR1,DR2

■ Maximum Absolute Ratings

Symbol	Parameters	Min.	Max.	Unit
VDD	Supply Voltage	-0.3	7	V
TOPR	Operating Temperature	-30	85	°C
TSTG	Storage Temperature	-65	150	°C

■ Application Circuit : (2Line x 40Word)

