

Marvell 88F6192 SoC with Sheeva Technology

Kirkwood Series



PRODUCT OVERVIEW

The Marvell® 88F6192 SoC with Sheeva™ embedded CPU technology, is a high-performance integrated controller for value class applications. It integrates the Marvell Sheeva CPU core which is fully ARMv5TE-compliant with a 256KB L2 Cache. The 88F6192 builds upon Marvell's innovative Feroceon® family of processors, improves performance, and adds new features to reduce bill of materials (BOM) costs. The 88F6192 is suitable for a wide range of applications such as routers, gateway, media server, storage, set-top-box, networking and printer products.

The 88F6192 offers unparalleled integration that makes system design simple and cost efficient. The SoC integrates:

- High-performance single-issue CPU
- 800 Mhz operating speed
- 16KB-Instruction and 16KB-Data 4-way, set-associative L1 cache
- 256KB unified 4-way, set-associative L2 cache
- 16-bit DDR2 memory interface (up to 400 MHz data rate)
- Two Gigabit Ethernet MACs with interface options
- Precise Timing Protocol and Audio Video Bridging
- Single PCI-Express port
- Single USB 2.0 port with integrated PHY
- Two SATA 2.0 ports with integrated PHYs
- Network security engine with various encryption algorithm support
- Audio and MPEG Transport Stream Interface
- Two TDM Channels, SDIO, NAND flash, SPI, TWISI, and Two UART interfaces

The innovative, on-chip crossbar architecture with any-to-any connectivity enables concurrent transactions among multiple units that results in high system throughput allowing system designers to create high-performance scalable systems. Tightly integrated CPU and memory controller significantly improves application performance.

BLOCK DIAGRAM

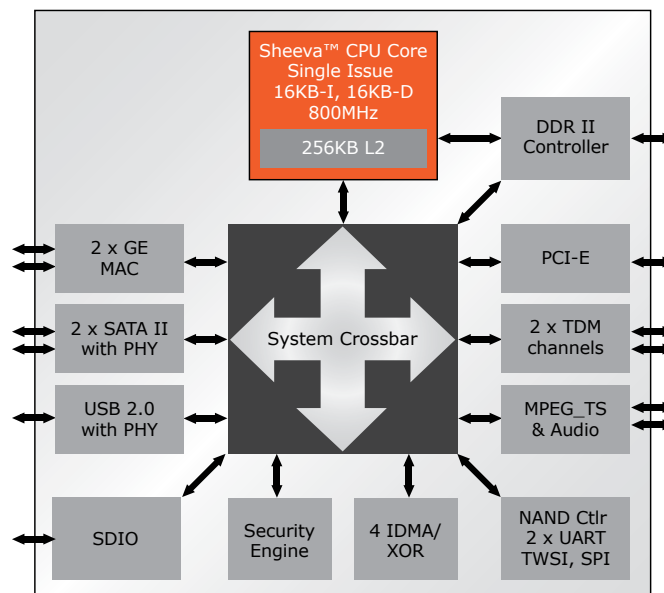

Fig 1. 88F6192 SoC Block Diagram

▶ **COMPREHENSIVE DEVELOPMENT TOOLS**

Marvell offers complete development platforms for the 88F6000 Series SoCs, enabling customers to start system development without waiting for their own hardware. Development platforms are available. Complete reference design platforms, including software drivers and board support packages for VxWorks, BSD and Linux, accelerate customer product development cycles.

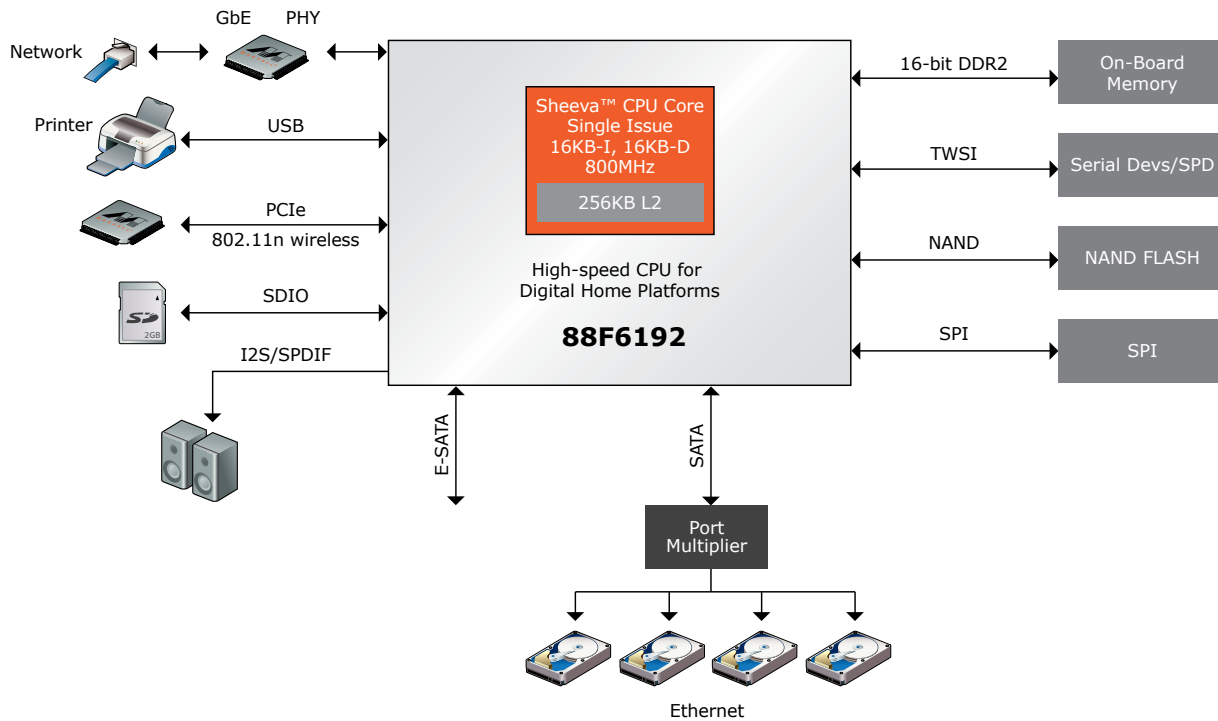

Fig 2. Marvell 88F6192— Typical System Implementation

THE MARVELL ADVANTAGE: Marvell products come with complete reference designs which include board layout designs, software, manufacturing diagnostic tools, documentation, and other items to assist customers with product evaluation and production. Marvell’s worldwide field application engineers collaborate closely with end customers to develop and deliver new leading-edge products for quick time-to-market. Marvell utilizes world-leading semiconductor foundry and packaging services to reliably deliver high-volume and low-cost total solutions.

ABOUT MARVELL: Marvell is a leader in storage, communications, and consumer silicon solutions. Marvell’s diverse product portfolio includes switching, transceiver, communications controller, processors, wireless, power management, and storage solutions that power the entire communications infrastructure, including enterprise, metro, home, and digital entertainment applications. For more information, visit our web site at www.marvell.com.



Marvell Semiconductor, Inc.
5488 Marvell Lane
Santa Clara, CA 95054
Phone 408.222.2500
www.marvell.com

Copyright © 2009. Marvell International Ltd. All rights reserved. Marvell, Moving Forward Faster, the Marvell logo, Alaska, AnyVoltage, DSP Switcher, Fastwriter, Feroceon, Libertas, Link Street, PHYAdvantage, Prestera, TopDog, Virtual Cable Tester, Yukon, and ZJ are registered trademarks of Marvell or its affiliates. CarrierSpan, LinkCrypt, Powered by Marvell Green PFC, Qdeo, QuietVideo, Sheeva, TwinD, UniMac, and VCT are trademarks of Marvell or its affiliates. Other names and brands may be claimed as the property of others.