

2-Mbit (128K x 16) Static RAM

Features

- Very high speed: 45 ns
- Wide voltage range: 2.20V–3.60V
- Pin-compatible with CY62137CV30
- Ultra-low standby power
 - Typical standby current: 1 μ A
 - Maximum standby current: 7 μ A
- Ultra-low active power
 - Typical active current: 2 mA @ f = 1 MHz
- Easy memory expansion with \overline{CE} , and \overline{OE} features
- Automatic power-down when deselected
- CMOS for optimum speed/power
- Byte power-down feature
- Offered in Pb-free 48-ball VFBGA and 44-pin TSOPII package

Functional Description^[1]

The CY62137EV30 is a high-performance CMOS static RAM organized as 128K words by 16 bits. This device features advanced circuit design to provide ultra-low active current. This is ideal for providing More Battery Life™ (MoBL[®]) in portable applications such as cellular telephones. The device also has an automatic power-down feature that significantly reduces power consumption by 90% when addresses are not toggling. The device can also be put into standby mode reducing power consumption by more than 99% when deselected (\overline{CE} HIGH or both \overline{BLE} and \overline{BHE} are HIGH). The input/output pins (I/O_0 through I/O_{15}) are placed in a high-impedance state when: deselected (\overline{CE} HIGH), outputs are disabled (\overline{OE} HIGH), both Byte High Enable and Byte Low Enable are disabled (\overline{BHE} , \overline{BLE} HIGH), or during a write operation (\overline{CE} LOW and \overline{WE} LOW).

Writing to the device is accomplished by asserting Chip Enable (\overline{CE}) and Write Enable (\overline{WE}) inputs LOW. If Byte Low Enable (\overline{BLE}) is LOW, then data from I/O pins (I/O_0 through I/O_7), is written into the location specified on the address pins (A_0 through A_{16}). If Byte High Enable (\overline{BHE}) is LOW, then data from I/O pins (I/O_8 through I/O_{15}) is written into the location specified on the address pins (A_0 through A_{16}).

Reading from the device is accomplished by asserting Chip Enable (\overline{CE}) and Output Enable (\overline{OE}) LOW while forcing the Write Enable (\overline{WE}) HIGH. If Byte Low Enable (\overline{BLE}) is LOW, then data from the memory location specified by the address pins will appear on I/O_0 to I/O_7 . If Byte High Enable (\overline{BHE}) is LOW, then data from memory will appear on I/O_8 to I/O_{15} . See the truth table at the back of this data sheet for a complete description of read and write modes.

The CY62137EV30 is available in 48-ball VFBGA and 44-pin TSOPII packages.

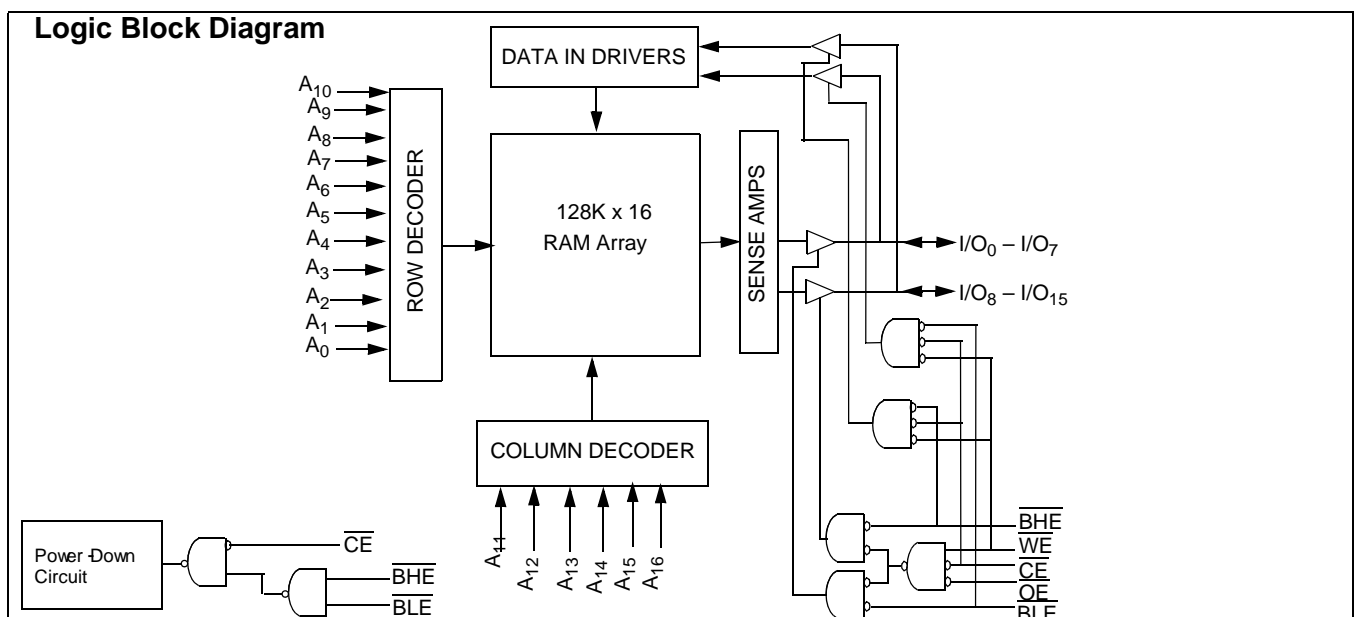

Note:

1. For best practice recommendations, please refer to the Cypress application note "System Design Guidelines" on <http://www.cypress.com>.

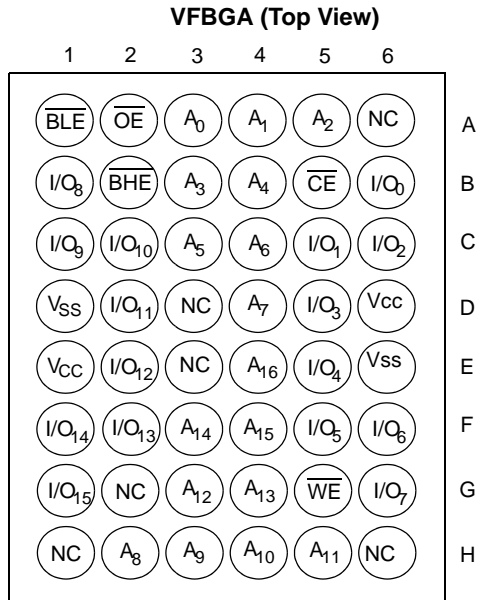
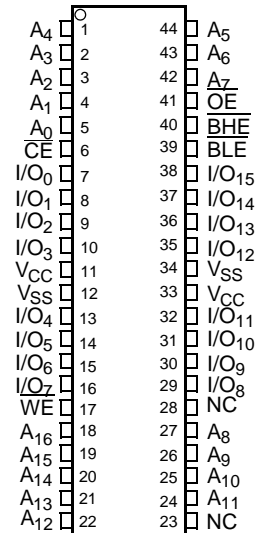
Pin Configurations^[2, 3]

44 TSOP II (Top View)

Product Portfolio

Product	V _{CC} Range (V)			Speed (ns)	Power Dissipation					
					Operating I _{CC} (mA)				Standby I _{SB2} (μA)	
					f = 1MHz		f = f _{max}			
					Min.	Typ. ^[7]	Max.	Typ. ^[7]	Max.	Typ. ^[7]
CY62137EV30-45LL	2.2V	3.0V	3.6V	45 ns	2	2.5	15	20	1	7

Note:

2. NC pins are not connected on the die.
3. Pins D3, H1, G2, and H6 in the BGA package are address expansion pins for 4 Mb, 8 Mb, 16 Mb, and 32 Mb, respectively.



Maximum Ratings

(Above which the useful life may be impaired. For user guidelines, not tested.)

Storage Temperature -65°C to + 150°C

Ambient Temperature with

Power Applied -55°C to + 125°C

Supply Voltage to Ground

Potential -0.3V to 3.9V ($V_{CC(MAX)} + 0.3V$)

DC Voltage Applied to Outputs

in High-Z State^[4, 5] -0.3V to 3.9V ($V_{CC MAX} + 0.3V$)

DC Input Voltage^[4, 5] -0.3V to 3.9V ($V_{CC MAX} + 0.3V$)

Output Current into Outputs (LOW) 20 mA

Static Discharge Voltage > 2001V
(per MIL-STD-883, Method 3015)

Latch-up Current > 200 mA

Operating Range

Device	Range	Ambient Temperature	$V_{CC}^{[6]}$
CY62137EV30-45LL	Industrial	-40°C to +85°C	2.2V to 3.6V

Electrical Characteristics Over the Operating Range

Parameter	Description	Test Conditions	45 ns			Unit
			Min.	Typ. ^[7]	Max.	
V _{OH}	Output HIGH Voltage	I _{OH} = -0.1 mA, V _{CC} = 2.20V	2.0			V
		I _{OH} = -1.0 mA, V _{CC} = 2.70V	2.4			V
V _{OL}	Output LOW Voltage	I _{OL} = 0.1 mA, V _{CC} = 2.20V			0.4	V
		I _{OL} = 2.1mA, V _{CC} = 2.70V			0.4	V
V _{IH}	Input HIGH Voltage	V _{CC} = 2.2V to 2.7V	1.8		V _{CC} + 0.3	V
		V _{CC} = 2.7V to 3.6V	2.2		V _{CC} + 0.3	V
V _{IL}	Input LOW Voltage	V _{CC} = 2.2V to 2.7V	-0.3		0.6	V
		V _{CC} = 2.7V to 3.6V	-0.3		0.8	V
I _{IX}	Input Leakage Current	GND ≤ V _I ≤ V _{CC}	-1		+1	μA
I _{OZ}	Output Leakage Current	GND ≤ V _O ≤ V _{CC} , Output Disabled	-1		+1	μA
I _{CC}	V _{CC} Operating Supply Current	f = f _{MAX} = 1/t _{RC} , V _{CC} = V _{CCmax} , I _{OUT} = 0 mA, CMOS levels		15	20	mA
		f = 1 MHz		2.0	2.5	
I _{SB1}	Automatic CE Power-down Current — CMOS Inputs	CE ₁ ≥ V _{CC} - 0.2V, CE ₂ ≤ 0.2V, V _{IN} ≥ V _{CC} - 0.2V, V _{IN} ≤ 0.2V, f = f _{MAX} (Address and Data Only), f = 0 (OE and WE), V _{CC} = 3.60V		1	7	μA
I _{SB2}	Automatic CE Power-down Current — CMOS Inputs	CE ₁ ≥ V _{CC} - 0.2V or CE ₂ ≤ 0.2V, V _{IN} ≥ V _{CC} - 0.2V or V _{IN} ≤ 0.2V, f = 0, V _{CC} = 3.60V		1	7	μA

Notes:

4. V_{IL(min.)} = -2.0V for pulse durations less than 20 ns.
5. V_{IH(max)} = V_{CC} + 0.75V for pulse durations less than 20ns.
6. Full Device AC operation assumes a 100 μs ramp time from 0 to V_{CC(min)} and 200 μs wait time after V_{CC} stabilization.
7. Typical values are included for reference only and are not guaranteed or tested. Typical values are measured at V_{CC} = V_{CC(typ.)}, T_A = 25°C.

Capacitance (for all packages)^[8]

Parameter	Description	Test Conditions	Max.	Unit
C _{IN}	Input Capacitance	T _A = 25°C, f = 1 MHz, V _{CC} = V _{CC(typ)}	10	pF
C _{OUT}	Output Capacitance		10	pF

Thermal Resistance

Parameter	Description	Test Conditions	BGA	TSOP II	Unit
Θ _{JA}	Thermal Resistance (Junction to Ambient) ^[8]	Still Air, soldered on a 3 x 4.5 inch, two-layer printed circuit board	75	77	°C/W
Θ _{JC}	Thermal Resistance (Junction to Case) ^[8]		10	13	°C/W

AC Test Loads and Waveforms

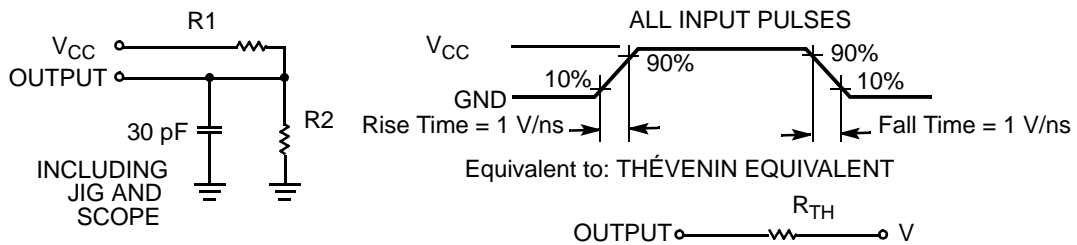

Parameters	2.50V	3.0V	Unit
R1	16667	1103	Ω
R2	15385	1554	Ω
R _{TH}	8000	645	Ω
V _{TH}	1.20	1.75	V

Data Retention Characteristics (Over the Operating Range)

Parameter	Description	Conditions	Min.	Typ. ^[7]	Max.	Unit
V _{DR}	V _{CC} for Data Retention		1			V
I _{CCDR}	Data Retention Current	V _{CC} = 1V CE ≥ V _{CC} - 0.2V, V _{IN} ≥ V _{CC} - 0.2V or V _{IN} ≤ 0.2V		0.8	3	μA
t _{CDR} ^[8]	Chip Deselect to Data Retention Time		0			ns
t _R ^[9]	Operation Recovery Time		t _{RC}			ns

Data Retention Waveform^[10]

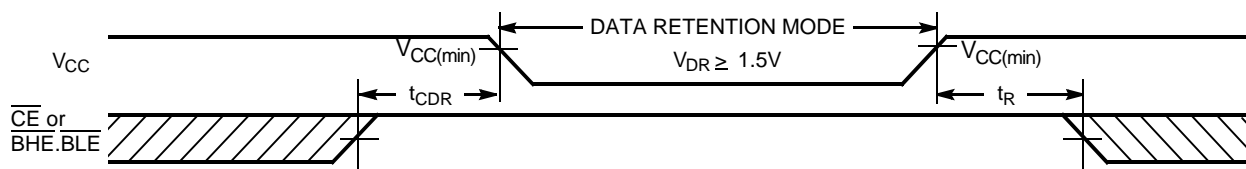

Notes:

- 8. Tested initially and after any design or process changes that may affect these parameters.
- 9. Full device operation requires linear V_{CC} ramp from V_{DR} to V_{CC(min.)} ≥ 100 μs or stable at V_{CC(min.)} ≥ 100 μs.

Switching Characteristics Over the Operating Range ^[11]

Parameter	Description	45 ns		Unit
		Min.	Max.	
Read Cycle				
t _{RC}	Read Cycle Time	45		ns
t _{AA}	Address to Data Valid		45	ns
t _{OHA}	Data Hold from Address Change	10		ns
t _{ACE}	$\overline{\text{CE}}$ LOW to Data Valid		45	ns
t _{DOE}	$\overline{\text{OE}}$ LOW to Data Valid		22	ns
t _{LZOE}	$\overline{\text{OE}}$ LOW to Low Z ^[12]	5		ns
t _{HZOE}	$\overline{\text{OE}}$ HIGH to High Z ^[12, 13]		18	ns
t _{LZCE}	$\overline{\text{CE}}$ LOW to Low Z ^[12]	10		ns
t _{HZCE}	$\overline{\text{CE}}$ HIGH to High Z ^[12, 13]		18	ns
t _{PU}	$\overline{\text{CE}}$ LOW to Power-Up	0		ns
t _{PD}	$\overline{\text{CE}}$ HIGH to Power-Down		45	ns
t _{DBE}	$\overline{\text{BLE/BHE}}$ LOW to Data Valid		45	ns
t _{LZBE}	$\overline{\text{BLE/BHE}}$ LOW to Low Z ^[12]	5		ns
t _{HZBE}	$\overline{\text{BLE/BHE}}$ HIGH to HIGH Z ^[12, 13]		18	ns
Write Cycle^[14]				
t _{WC}	Write Cycle Time	45		ns
t _{SCE}	$\overline{\text{CE}}$ LOW to Write End	35		ns
t _{AW}	Address Set-Up to Write End	35		ns
t _{HA}	Address Hold from Write End	0		ns
t _{SA}	Address Set-Up to Write Start	0		ns
t _{PWE}	$\overline{\text{WE}}$ Pulse Width	35		ns
t _{BW}	$\overline{\text{BLE/BHE}}$ LOW to Write End	35		ns
t _{SD}	Data Set-Up to Write End	25		ns
t _{HD}	Data Hold from Write End	0		ns
t _{HZWE}	$\overline{\text{WE}}$ LOW to High-Z ^[12, 13]		18	ns
t _{LZWE}	$\overline{\text{WE}}$ HIGH to Low-Z ^[12]	10		ns

Notes:

10. $\overline{\text{BHE.BLE}}$ is the AND of both $\overline{\text{BHE}}$ and $\overline{\text{BLE}}$. The chip can be deselected by either disabling the chip enable signals or by disabling both $\overline{\text{BHE}}$ and $\overline{\text{BLE}}$.
11. Test conditions for all parameters other than tri-state parameters assume signal transition time of 3 ns (1V/ns) or less, timing reference levels of $V_{CC(\text{typ})}/2$, input pulse levels of 0 to $V_{CC(\text{typ})}$, and output loading of the specified I_{OL}/I_{OH} as shown in the "AC Test Loads and Waveforms" section.
12. At any given temperature and voltage condition, t_{HZCE} is less than t_{LZCE} , t_{HZBE} is less than t_{LZBE} , t_{HZOE} is less than t_{LZOE} , and t_{HZWE} is less than t_{LZWE} for any given device.
13. t_{HZOE} , t_{HZCE} , t_{HZBE} , and t_{HZWE} transitions are measured when the outputs enter a high-impedance state.
14. The internal Write time of the memory is defined by the overlap of $\overline{\text{WE}}$, $\overline{\text{CE}} = V_{IL}$, $\overline{\text{BHE}}$ and/or $\overline{\text{BLE}} = V_{IL}$. All signals must be ACTIVE to initiate a write and any of these signals can terminate a write by going INACTIVE. The data input set-up and hold timing should be referenced to the edge of the signal that terminates the write.

Switching Waveforms (continued)

Write Cycle No. 1 ($\overline{\text{WE}}$ Controlled)^[14, 18, 19]

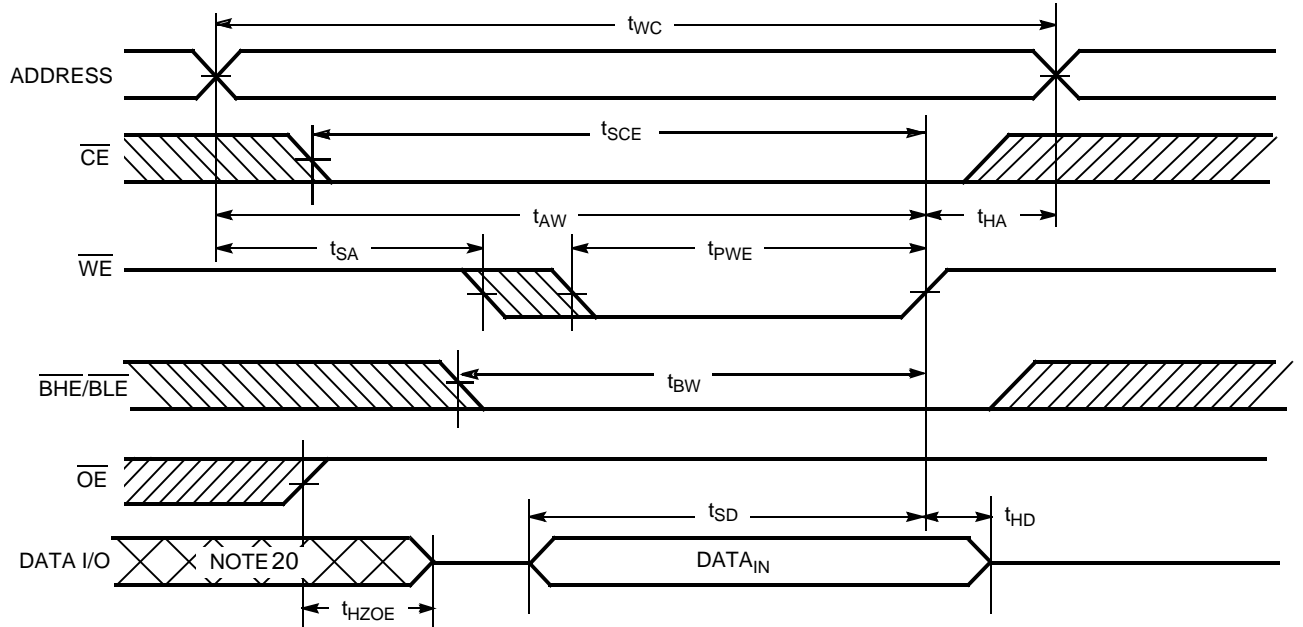

Write Cycle No. 2 ($\overline{\text{CE}}$ Controlled)^[14, 18, 19]

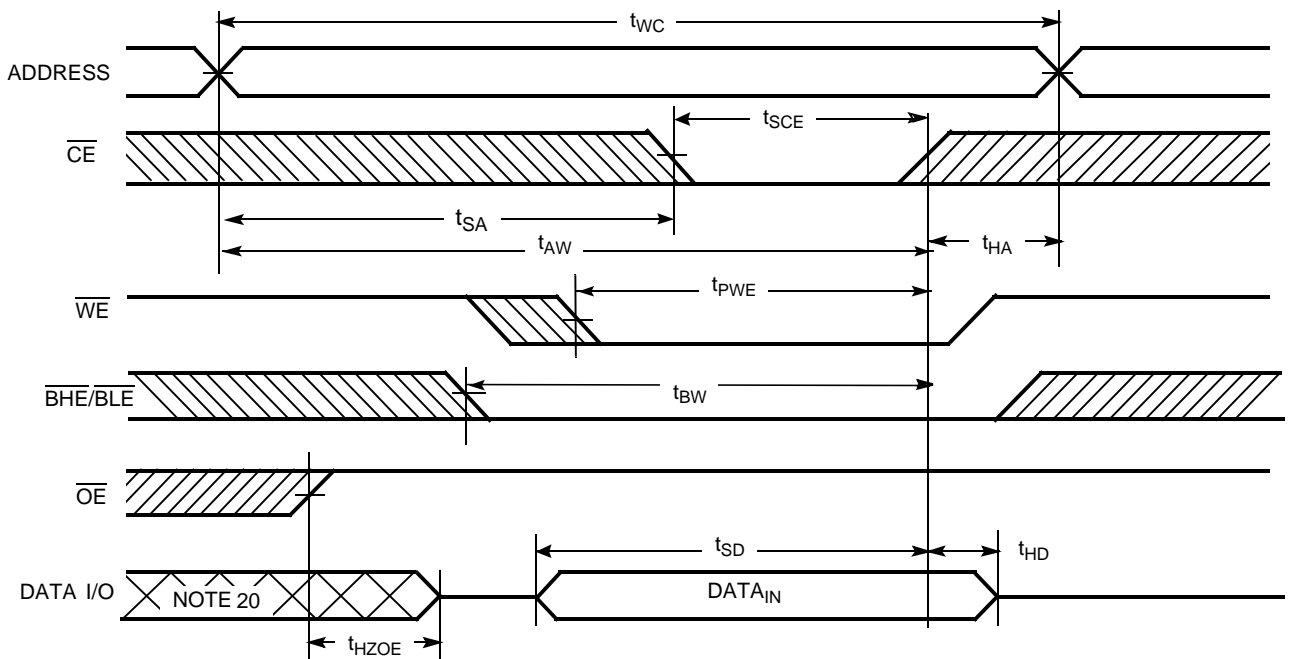

Notes:

- 18. Data I/O is high impedance if $\overline{\text{OE}} = V_{\text{IH}}$.
- 19. If $\overline{\text{CE}}$ goes HIGH simultaneously with $\text{WE} = V_{\text{IH}}$, the output remains in a high-impedance state.
- 20. During this period, the I/Os are in output state and input signals should not be applied.

Truth Table

$\overline{\text{CE}}$	$\overline{\text{WE}}$	$\overline{\text{OE}}$	$\overline{\text{BHE}}$	$\overline{\text{BLE}}$	Inputs/Outputs	Mode	Power
H	X	X	X	X	High Z	Deselect/Power-down	Standby (I_{SB})
X	X	X	H	H	High Z	Deselect/Power-down	Standby (I_{SB})
L	H	L	L	L	Data Out (I/O ₀ –I/O ₁₅)	Read	Active (I_{CC})
L	H	L	H	L	Data Out (I/O ₀ –I/O ₇); I/O ₈ –I/O ₁₅ in High Z	Read	Active (I_{CC})
L	H	L	L	H	Data Out (I/O ₈ –I/O ₁₅); I/O ₀ –I/O ₇ in High Z	Read	Active (I_{CC})
L	H	H	L	L	High Z	Output Disabled	Active (I_{CC})
L	H	H	H	L	High Z	Output Disabled	Active (I_{CC})
L	H	H	L	H	High Z	Output Disabled	Active (I_{CC})
L	L	X	L	L	Data In (I/O ₀ –I/O ₁₅)	Write	Active (I_{CC})
L	L	X	H	L	Data In (I/O ₀ –I/O ₇); I/O ₈ –I/O ₁₅ in High Z	Write	Active (I_{CC})
L	L	X	L	H	Data In (I/O ₈ –I/O ₁₅); I/O ₀ –I/O ₇ in High Z	Write	Active (I_{CC})

Ordering Information

Speed (ns)	Ordering Code	Package Diagram	Package Type	Operating Range
45	CY62137EV30LL-45BVXI	51-85150	48-ball Very Fine Pitch BGA (6 mm x 8mm x 1 mm) (Pb-free)	Industrial
45	CY62137EV30LL-45ZSXI	51-85087	44-pin TSOP II (Pb-free)	

Package Diagrams

48-pin VFBGA (6 x 8 x 1 mm) (51-85150)

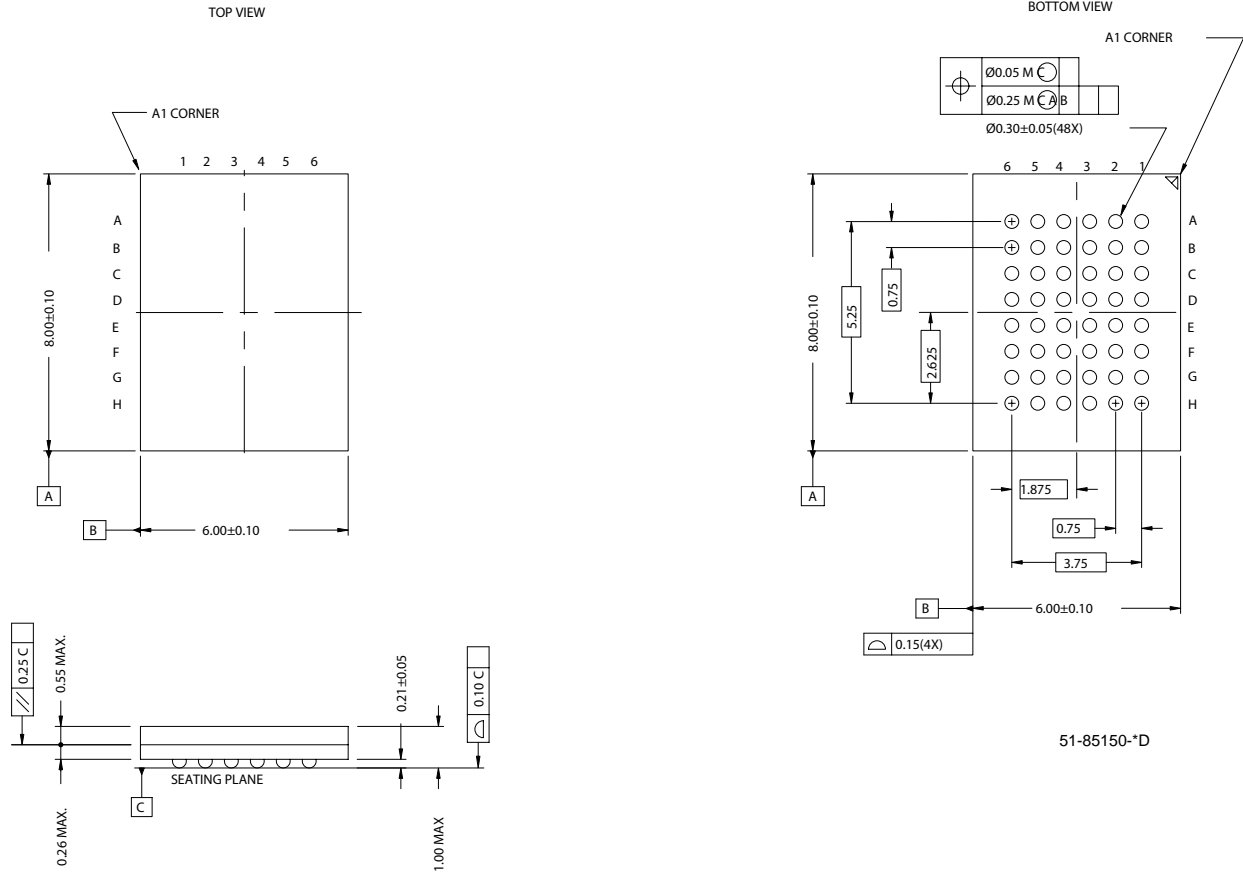

Package Diagrams (continued)

44-Pin TSOP II (51-85087)

DIMENSION IN MM (INCH)
MAX
MIN

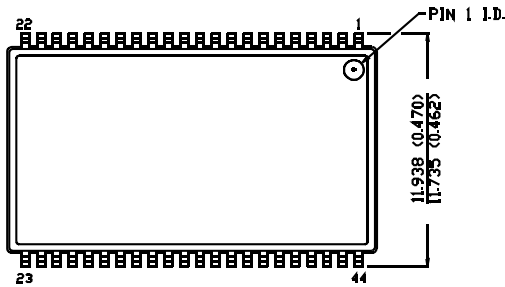

TOP VIEW

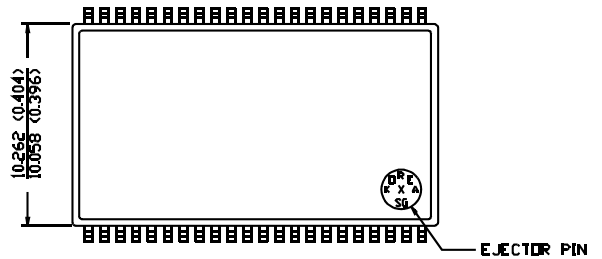

BOTTOM VIEW

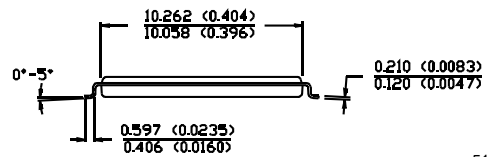
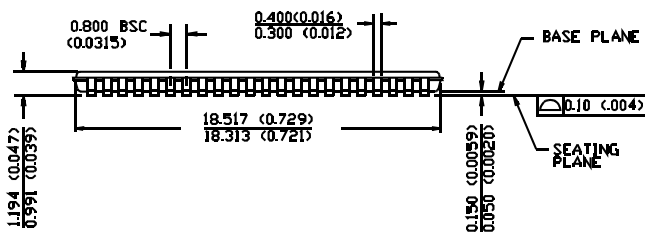

51-85087-A

MoBL is a registered trademark, and More Battery Life is a trademark, of Cypress Semiconductor. All product and company names mentioned in this document may be the trademarks of their respective holders.

Document History Page

Document Title: CY62137EV30 MoBL [®] 2-Mbit (128K x 16) Static RAM Document Number: 38-05443				
REV.	ECN NO.	Issue Date	Orig. of Change	Description of Change
**	203720	See ECN	AJU	New Data Sheet
*A	234196	See ECN	AJU	Changed I _{CC} MAX at f=1MHz from 1.7 mA to 2.0 mA Changed I _{CC} TYP from 12 mA (35 ns speed bin) and 10 mA (45 ns speed bin) to 15 mA and 12 mA respectively Changed I _{CC} MAX from 20 mA (35 ns speed bin) and 15 mA (45 ns speed bin) to 25 mA and 20 mA respectively Changed I _{SB1} and I _{SB2} TYP from 0.6 μA to 0.7 μA Changed I _{SB1} and I _{SB2} MAX from 1.5 μA to 2.5 μA Changed I _{CCDR} from 1 μA to 2 μA Fixed typos on TSOP II pinout: Pin 18-22: address lines Pin 23: NC Added Pb-free information
*B	427817	See ECN	NXR	Converted from Advanced Information to Final. Removed 35 ns Speed Bin Removed "L" version Changed ball E3 from DNU to NC. Removed the redundant footnote on DNU. Moved Product Portfolio from Page # 3 to Page #2. Changed I _{CC} (Max) value from 2 mA to 2.5 mA and I _{CC} (Typ) value from 1.5 mA to 2 mA at f=1 MHz Changed I _{CC} (Typ) value from 12 mA to 15 mA at f = f _{max} =1/t _{RC} Changed I _{SB1} and I _{SB2} Typ. values from 0.7 μA to 1 μA and Max. values from 2.5 μA to 7 μA. Changed V _{CC} stabilization time in footnote #7 from 100 μs to 200 μs Changed the AC test load capacitance from 50pF to 30pF on Page# 4 Changed V _{DR} from 1.5V to 1V on Page# 4. Changed I _{CCDR} from 2 μA to 3 μA. Added I _{CCDR} typical value. Corrected t _R in Data Retention Characteristics from 100 μs to t _{RC} ns Changed t _{OHA} , t _{LZCE} and t _{LZWE} from 6 ns to 10 ns Changed t _{LZBE} from 6 ns to 5 ns Changed t _{LZOE} from 3 ns to 5 ns Changed t _{HZOE} , t _{HZCE} , t _{HZBE} and t _{HZWE} from 15 ns to 18 ns Changed t _{SCE} , t _{AW} and t _{BW} from 40 ns to 35 ns Changed t _{PWE} from 30 ns to 35 ns Changed t _{SD} from 20 ns to 25 ns Updated the Ordering Information table and replaced the Package Name column with Package Diagram.