

128K x 8 HIGH-SPEED CMOS STATIC RAM

JANUARY 2005

FEATURES

- High-speed access time: 12, 15 ns
- Low active power: 160 mW (typical)
- Low standby power: 1000 μ W (typical) CMOS standby
- Output Enable (\overline{OE}) and two Chip Enable ($\overline{CE1}$ and CE2) inputs for ease in applications
- Fully static operation: no clock or refresh required
- TTL compatible inputs and outputs
- Single 5V ($\pm 10\%$) power supply
- Commercial, industrial, and automotive temperature ranges available
- Lead free available

DESCRIPTION

The *ISSI* IS61C1024AL/IS64C1024AL is a very high-speed, low power, 131,072-word by 8-bit CMOS static RAMs. They are fabricated using *ISSI*'s high-performance CMOS technology. This highly reliable process coupled with innovative circuit design techniques, yields higher performance and low power consumption devices.

When $\overline{CE1}$ is HIGH or CE2 is LOW (deselected), the device assumes a standby mode at which the power dissipation can be reduced by using CMOS input levels.

Easy memory expansion is provided by using two Chip Enable inputs, $\overline{CE1}$ and CE2. The active LOW Write Enable (\overline{WE}) controls both writing and reading of the memory.

The IS61C1024AL/IS64C1024AL is available in 32-pin 300-mil SOJ, 32-pin 400-mil SOJ, 32-pin TSOP (Type I, 8x20), and 32-pin sTSOP (Type I, 8 x 13.4) packages.

FUNCTIONAL BLOCK DIAGRAM

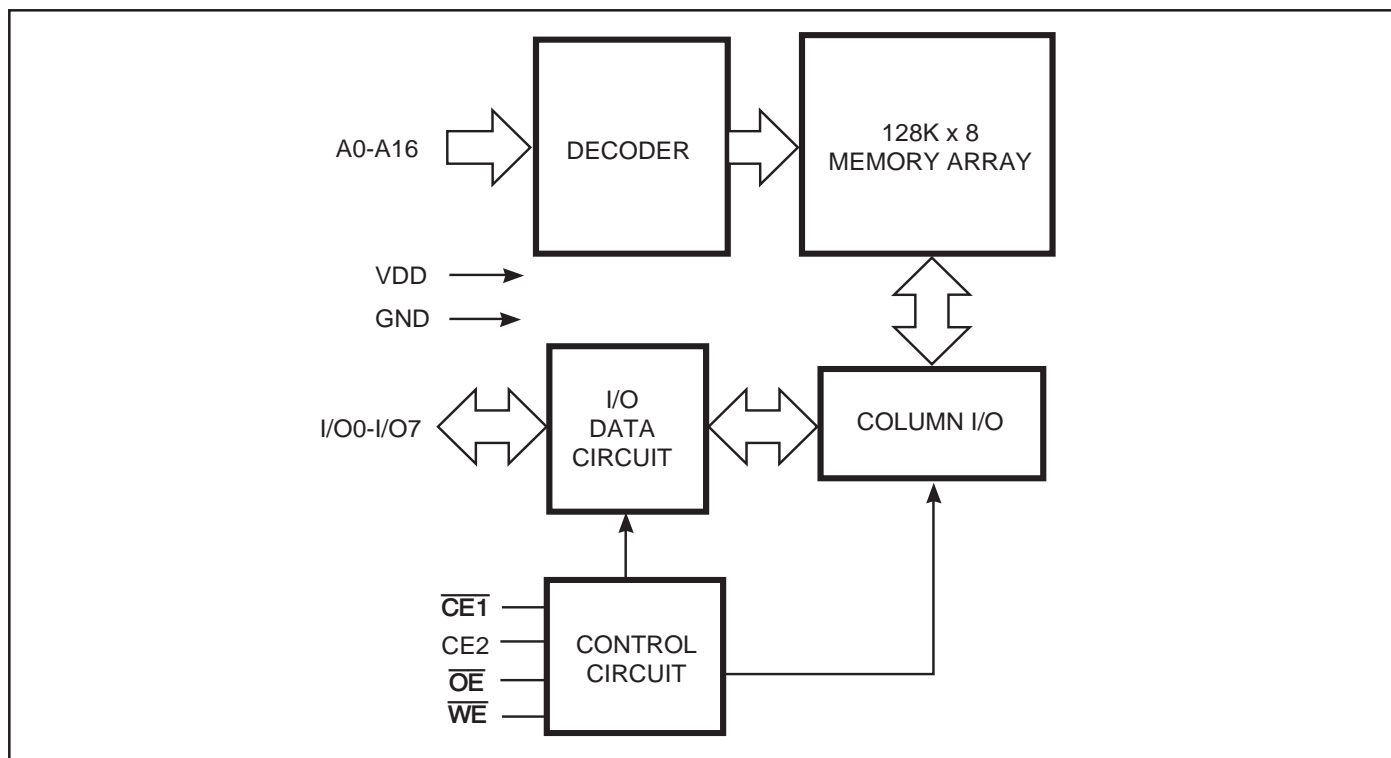

Copyright © 2005 Integrated Silicon Solution, Inc. All rights reserved. ISSI reserves the right to make changes to this specification and its products at any time without notice. ISSI assumes no liability arising out of the application or use of any information, products or services described herein. Customers are advised to obtain the latest version of this device specification before relying on any published information and before placing orders for products.

PIN CONFIGURATION
32-Pin SOJ

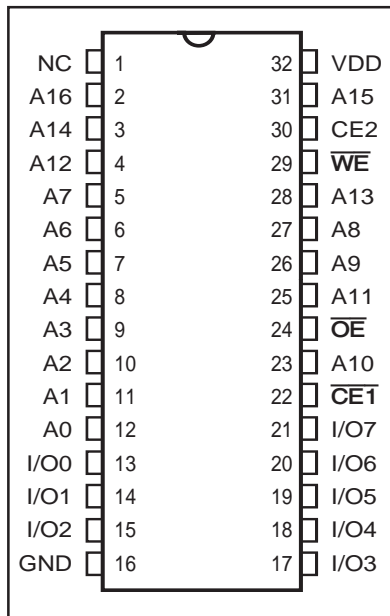

PIN CONFIGURATION
32-Pin TSOP (Type 1) (T) and sTSOP (Type 1) (H)

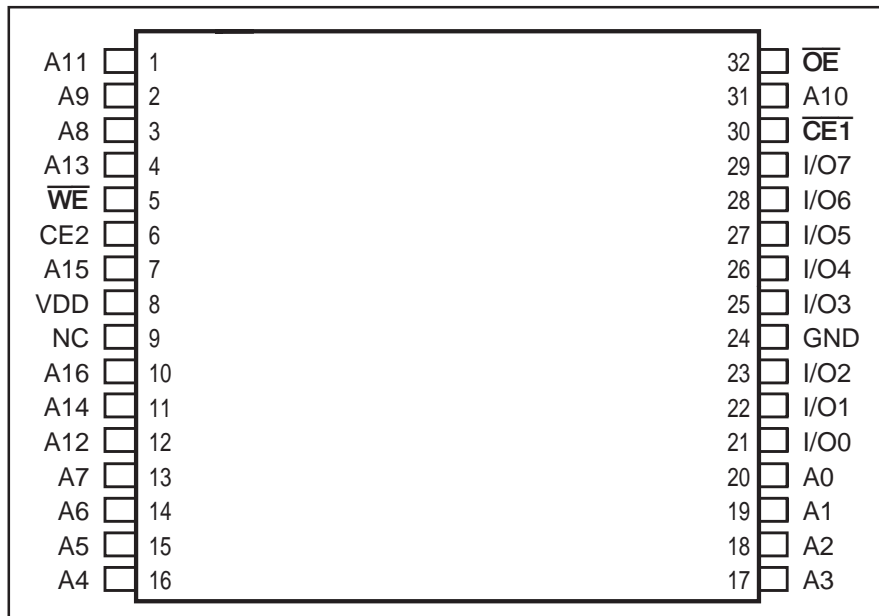

PIN DESCRIPTIONS

A0-A16	Address Inputs
$\overline{CE1}$	Chip Enable 1 Input
CE2	Chip Enable 2 Input
\overline{OE}	Output Enable Input
\overline{WE}	Write Enable Input
I/O0-I/O7	Input/Output
V _{DD}	Power
GND	Ground

OPERATING RANGE (IS61C1024AL)

Range	Ambient Temperature	V _{DD}
Commercial	0°C to +70°C	5V ± 10%
Industrial	-40°C to +85°C	5V ± 10%

OPERATING RANGE (IS64C1024AL)

Range	Ambient Temperature	V _{DD}
Automotive	-40°C to +125°C	5V ± 10%

TRUTH TABLE

Mode	\overline{WE}	$\overline{CE1}$	CE2	\overline{OE}	I/O Operation	V _{DD} Current
Not Selected	X	H	X	X	High-Z	I _{SB1} , I _{SB2}
(Power-down)	X	X	L	X	High-Z	I _{SB1} , I _{SB2}
Output Disabled	H	L	H	H	High-Z	I _{CC1} , I _{CC2}
Read	H	L	H	L	D _{OUT}	I _{CC1} , I _{CC2}
Write	L	L	H	X	D _{IN}	I _{CC1} , I _{CC2}

IS61C1024AL, IS64C1024AL

ABSOLUTE MAXIMUM RATINGS⁽¹⁾

Symbol	Parameter	Value	Unit
V _{TERM}	Terminal Voltage with Respect to GND	-0.5 to +7.0	V
T _{STG}	Storage Temperature	-65 to +150	°C
P _T	Power Dissipation	1.5	W
I _{OUT}	DC Output Current (LOW)	20	mA

Notes:

1. Stress greater than those listed under ABSOLUTE MAXIMUM RATINGS may cause permanent damage to the device. This is a stress rating only and functional operation of the device at these or any other conditions above those indicated in the operational sections of this specification is not implied. Exposure to absolute maximum rating conditions for extended periods may affect reliability.

CAPACITANCE^(1,2)

Symbol	Parameter	Conditions	Max.	Unit
C _{IN}	Input Capacitance	V _{IN} = 0V	5	pF
C _{OUT}	Output Capacitance	V _{OUT} = 0V	7	pF

Notes:

1. Tested initially and after any design or process changes that may affect these parameters.
2. Test conditions: T_A = 25°C, f = 1 MHz, V_{DD} = 5.0V.

DC ELECTRICAL CHARACTERISTICS (Over Operating Range)

Symbol	Parameter	Test Conditions	Min.	Max.	Unit	
V _{OH}	Output HIGH Voltage	V _{DD} = Min., I _{OH} = -4.0 mA	2.4	—	V	
V _{OL}	Output LOW Voltage	V _{DD} = Min., I _{OL} = 8.0 mA	—	0.4	V	
V _{IH}	Input HIGH Voltage		2.2	V _{DD} + 0.5	V	
V _{IL}	Input LOW Voltage ⁽¹⁾		-0.3	0.8	V	
I _{LI}	Input Leakage	GND ≤ V _{IN} ≤ V _{DD}	Com. Ind. Auto.	-1 -2 -5	1 2 5	μA
I _{LO}	Output Leakage	GND ≤ V _{OUT} ≤ V _{DD} Outputs Disabled	Com. Ind. Auto.	-1 -2 -5	1 2 5	μA

Note:

1. V_{IL} = -3.0V for pulse width less than 10 ns.

IS61C1024AL/IS64C1024AL POWER SUPPLY CHARACTERISTICS⁽¹⁾ (Over Operating Range)

Symbol	Parameter	Test Conditions		-12 ns		-15 ns		Unit
				Min.	Max.	Min.	Max.	
I _{CC1}	V _{DD} Operating Supply Current	V _{DD} = V _{DD MAX.} , $\overline{CE1} = V_{IL}$ I _{OUT} = 0 mA, f = 0	Com.	—	35			mA
			Ind.	—	40			
			Auto.			—	45	
I _{CC2}	V _{DD} Dynamic Operating Supply Current	V _{DD} = V _{DD MAX.} , $\overline{CE1} = V_{IL}$ I _{OUT} = 0 mA, f = f _{MAX}	Com.	—	45			mA
			Ind.	—	50			
			Auto. typ. ⁽²⁾	—	32	—	55	
I _{SB1}	TTL Standby Current (TTL Inputs)	V _{DD} = V _{DD MAX.} , V _{IN} = V _{IH} or V _{IL} $\overline{CE1} \geq V_{IH}$, f = 0 or CE2 ≤ V _{IL} , f = 0	Com.	—	1			mA
			Ind.	—	1.5			
			Auto.			—	2	
I _{SB2}	CMOS Standby Current (CMOS Inputs)	V _{DD} = V _{DD MAX.} , $\overline{CE1} \geq V_{DD} - 0.2V$, CE2 ≤ 0.2V V _{IN} ≥ V _{DD} - 0.2V, or V _{IN} ≤ 0.2V, f = 0	Com.	—	400			μA
			Ind.	—	450			
			Auto. typ. ⁽²⁾	—	200	—	500	

Note:

- At f = f_{MAX}, address and data inputs are cycling at the maximum frequency, f = 0 means no input lines change.
- Typical Values are measured at V_{DD} = 5V, T_A = 25°C and not 100% tested.

IS61C1024AL, IS64C1024AL

READ CYCLE SWITCHING CHARACTERISTICS⁽¹⁾ (Over Operating Range)

Symbol	Parameter	-12		-15		Unit
		Min.	Max.	Min.	Max.	
t _{RC}	Read Cycle Time	12	—	15	—	ns
t _{AA}	Address Access Time	—	12	—	15	ns
t _{OH}	Output Hold Time	3	—	3	—	ns
t _{ACE1}	$\overline{CE1}$ Access Time	—	12	—	15	ns
t _{ACE2}	CE2 Access Time	—	12	—	15	ns
t _{DOE}	\overline{OE} Access Time	—	6	—	7	ns
t _{LZOE} ⁽²⁾	\overline{OE} to Low-Z Output	0	—	0	—	ns
t _{HZOE} ⁽²⁾	\overline{OE} to High-Z Output	0	6	0	6	ns
t _{LZCE1} ⁽²⁾	$\overline{CE1}$ to Low-Z Output	2	—	2	—	ns
t _{LZCE2} ⁽²⁾	CE2 to Low-Z Output	2	—	2	—	ns
t _{HZCE} ⁽²⁾	$\overline{CE1}$ or CE2 to High-Z Output	0	7	0	8	ns
t _{PU} ⁽³⁾	$\overline{CE1}$ or CE2 to Power-Up	0	—	0	—	ns
t _{PD} ⁽³⁾	$\overline{CE1}$ or CE2 to Power-Down	—	12	—	12	ns

Notes:

1. Test conditions assume signal transition times of 3 ns or less, timing reference levels of 1.5V, input pulse levels of 0 to 3.0V and output loading specified in Figure 1.
2. Tested with the load in Figure 2. Transition is measured ± 500 mV from steady-state voltage. Not 100% tested.
3. Not 100% tested.

AC TEST CONDITIONS

Parameter	Unit
Input Pulse Level	0V to 3.0V
Input Rise and Fall Times	3 ns
Input and Output Timing and Reference Level	1.5V
Output Load	See Figures 1 and 2

AC TEST LOADS

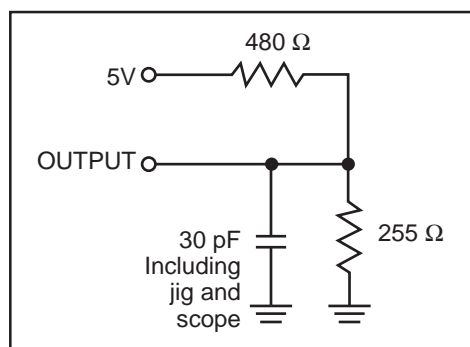

Figure 1

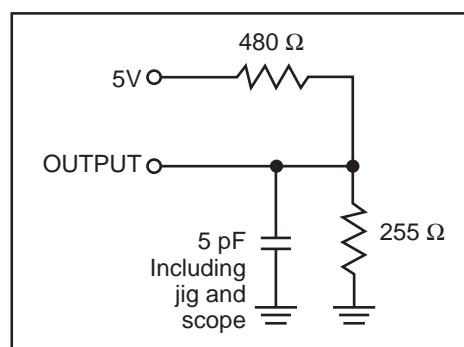
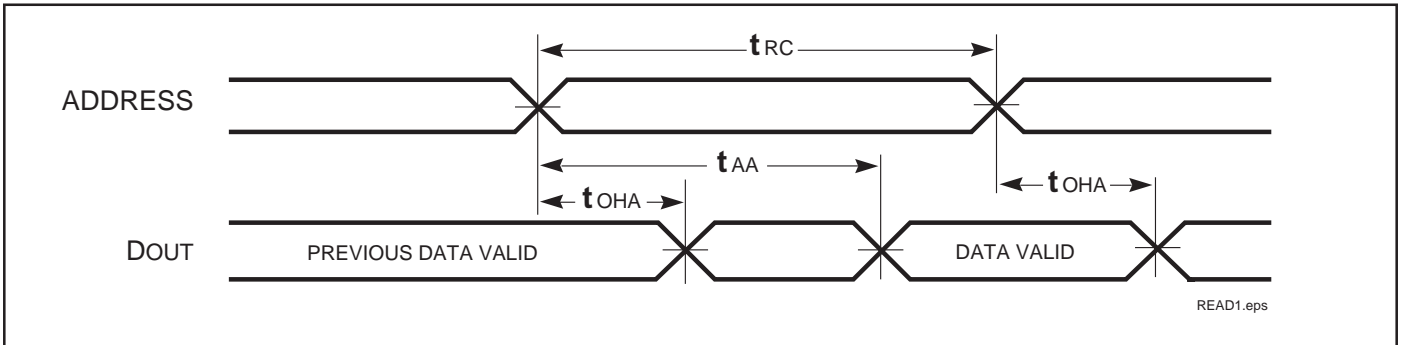

Figure 2

AC WAVEFORMS

READ CYCLE NO. 1^(1,2)



READ CYCLE NO. 2^(1,3)

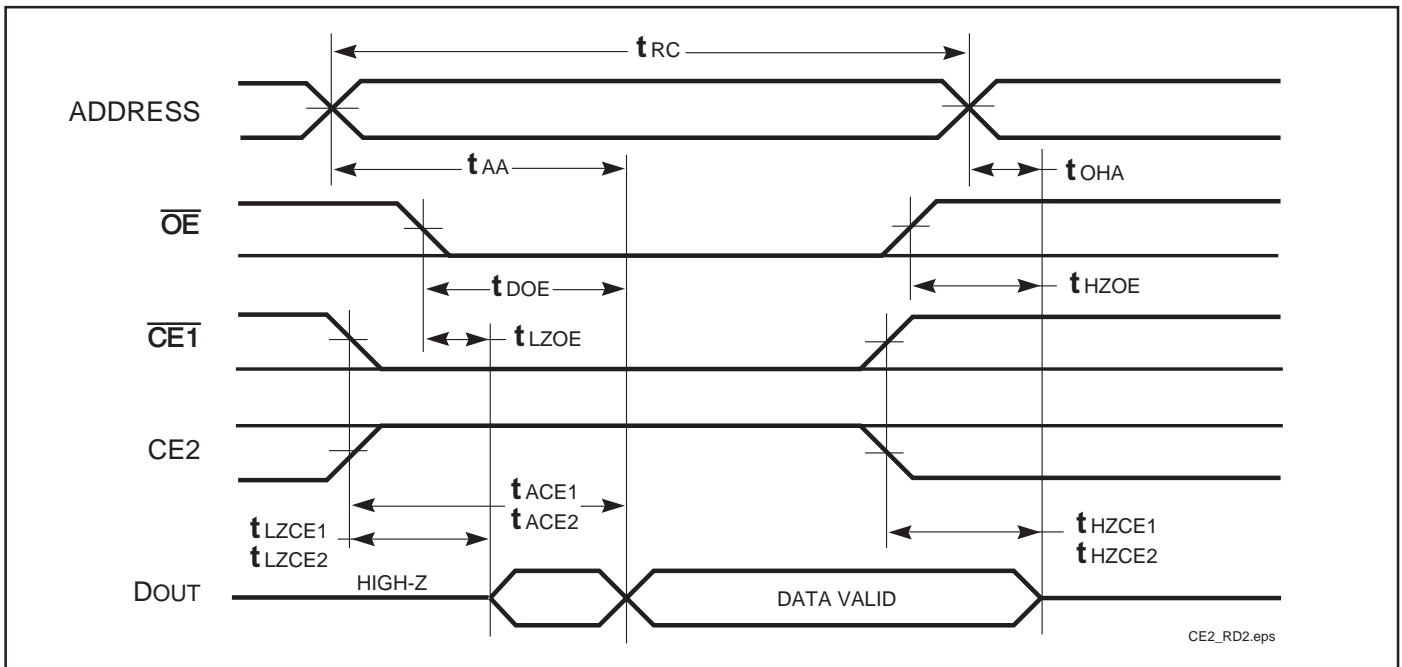

Notes:

1. \overline{WE} is HIGH for a Read Cycle.
2. The device is continuously selected. \overline{OE} , $\overline{CE1}$ = V_{IL} , CE2 = V_{IH} .
3. Address is valid prior to or coincident with $\overline{CE1}$ LOW and CE2 HIGH transitions.

WRITE CYCLE SWITCHING CHARACTERISTICS^(1,2) (Over Operating Range, Standard and Low Power)

Symbol	Parameter	-12 ns		-15 ns		Unit
		Min.	Max.	Min.	Max.	
t _{WC}	Write Cycle Time	12	—	15	—	ns
t _{SCE1}	$\overline{\text{CE1}}$ to Write End	10	—	12	—	ns
t _{SCE2}	CE2 to Write End	10	—	12	—	ns
t _{AW}	Address Setup Time to Write End	10	—	12	—	ns
t _{HA}	Address Hold from Write End	0	—	0	—	ns
t _{SA}	Address Setup Time	0	—	0	—	ns
t _{PWE⁽³⁾}	$\overline{\text{WE}}$ Pulse Width	10	—	12	—	ns
t _{SD}	Data Setup to Write End	7	—	10	—	ns
t _{HD}	Data Hold from Write End	0	—	0	—	ns
t _{HZWE⁽⁴⁾}	$\overline{\text{WE}}$ LOW to High-Z Output	—	7	—	7	ns
t _{LZWE⁽⁴⁾}	$\overline{\text{WE}}$ HIGH to Low-Z Output	2	—	2	—	ns

Notes:

1. Test conditions assume signal transition times of 5 ns or less, timing reference levels of 1.5V, input pulse levels of 0 to 3.0V and output loading specified in Figure 1.
2. The internal write time is defined by the overlap of $\overline{\text{CE1}}$ LOW, CE2 HIGH and $\overline{\text{WE}}$ LOW. All signals must be in valid states to initiate a Write, but any one can go inactive to terminate the Write. The Data Input Setup and Hold timing are referenced to the rising or falling edge of the signal that terminates the Write.
3. Tested with $\overline{\text{OE}}$ HIGH.
4. Tested with the load in Figure 2. Transition is measured ± 500 mV from steady-state voltage. Not 100% tested.

AC WAVEFORMS

WRITE CYCLE NO. 1 ($\overline{CE1}$ Controlled, \overline{OE} is HIGH or LOW) ⁽¹⁾

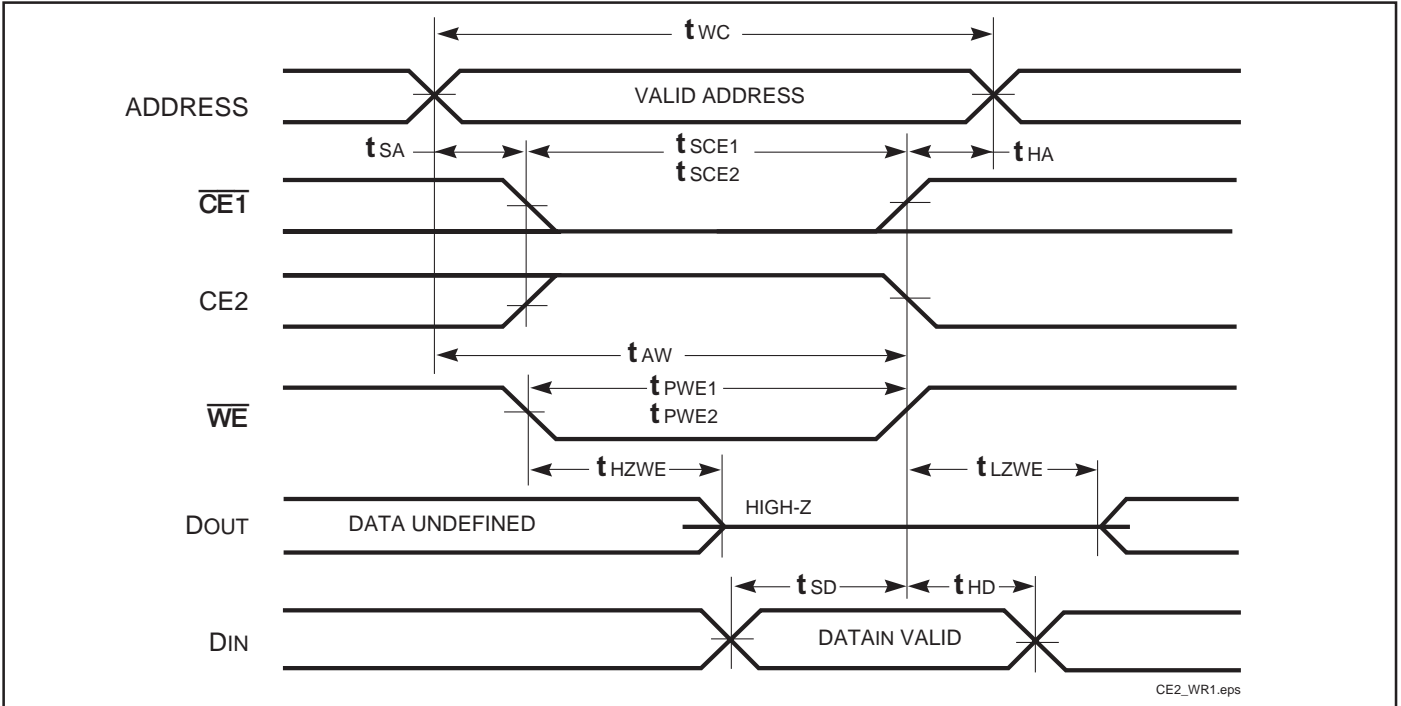

WRITE CYCLE NO. 2 (\overline{OE} is HIGH During Write Cycle) ^(1,2)

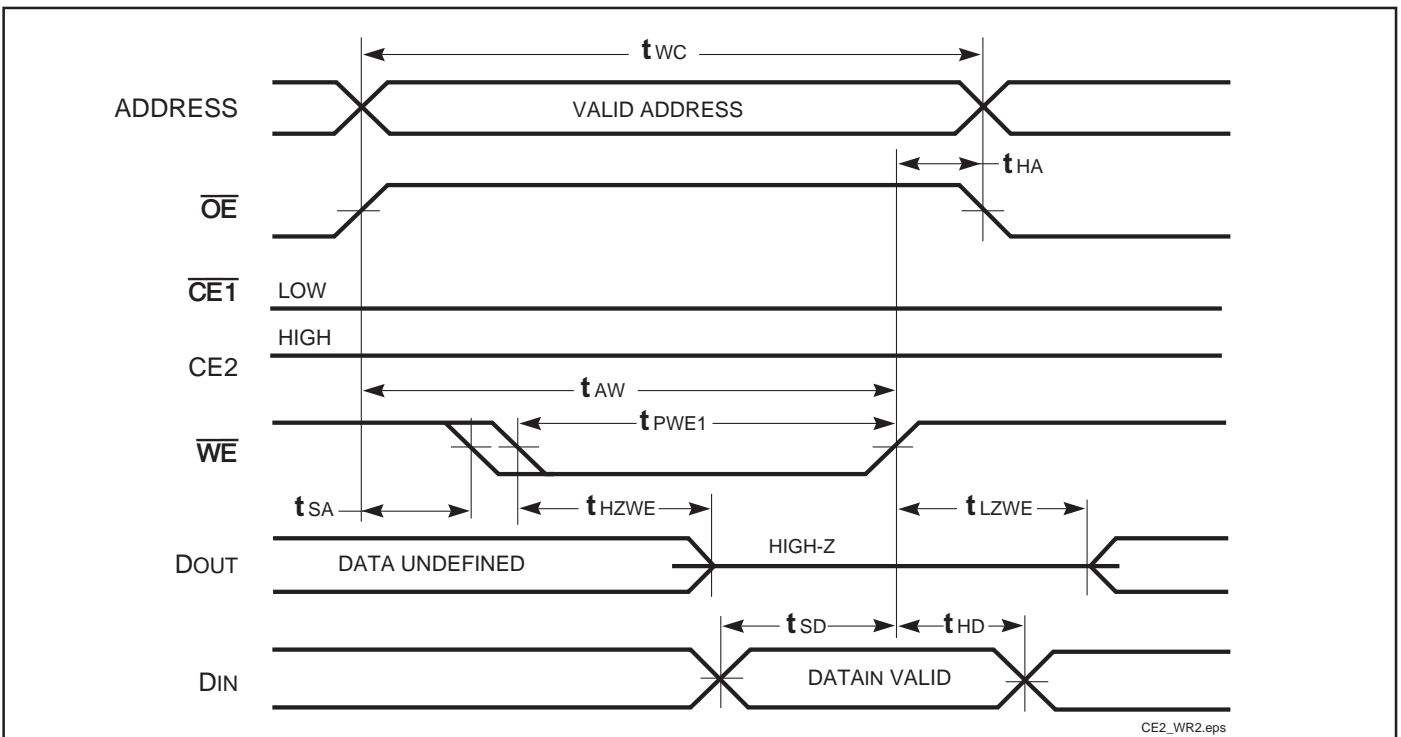

Notes:

1. The internal write time is defined by the overlap of $\overline{CE1}$ LOW, CE2 HIGH and \overline{WE} LOW. All signals must be in valid states to initiate a Write, but any one can go inactive to terminate the Write. The Data Input Setup and Hold timing are referenced to the rising or falling edge of the signal that terminates the Write.
2. I/O will assume the High-Z state if $\overline{OE} = V_{IH}$.

WRITE CYCLE NO. 3 (\overline{OE} is LOW During Write Cycle) ⁽¹⁾

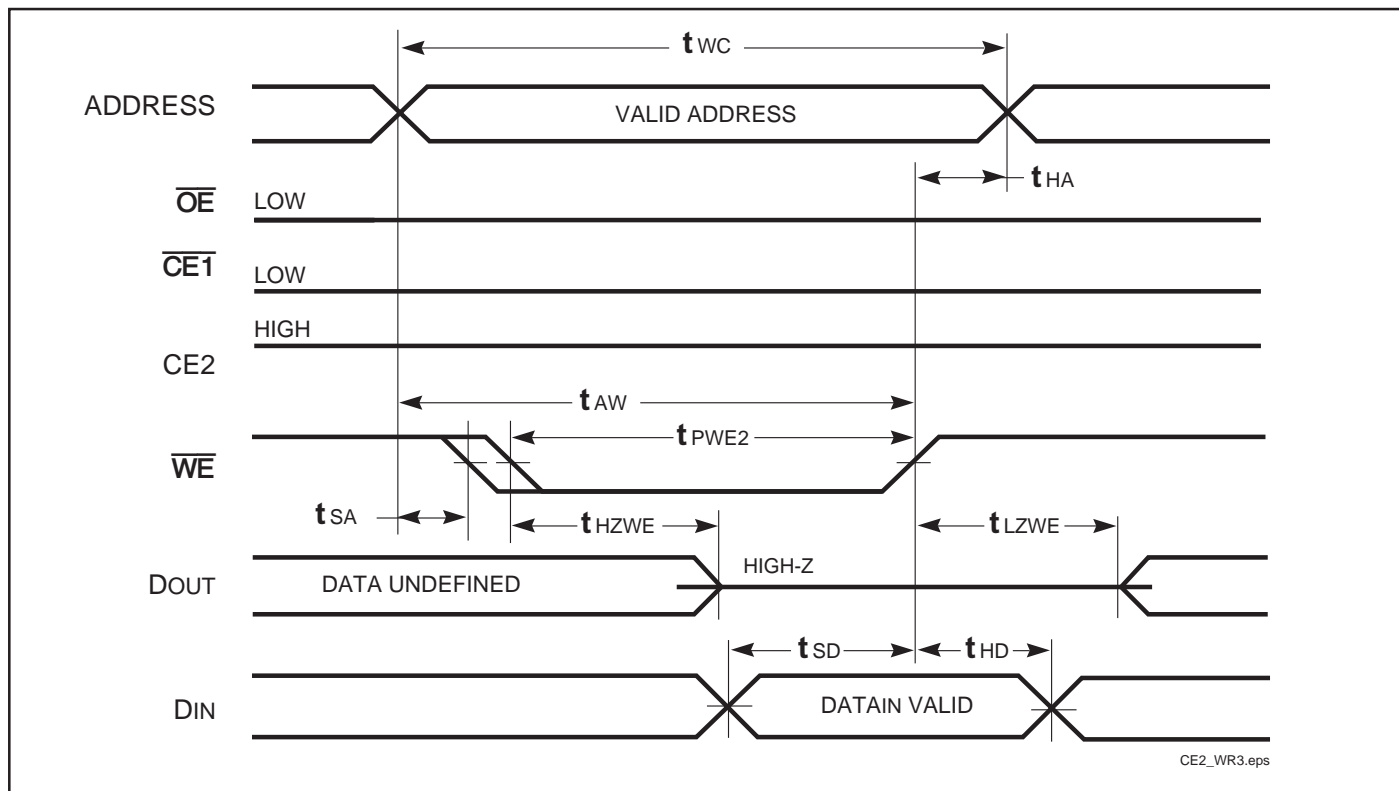

DATA RETENTION SWITCHING CHARACTERISTICS

Symbol	Parameter	Test Condition	Min.	Typ. ⁽¹⁾	Max.	Unit
V _{DR}	V _{DD} for Data Retention	See Data Retention Waveform	2.0		5.5	V
I _{DR}	Data Retention Current	V _{DD} = 2.0V, $\overline{CE1} \geq V_{DD} - 0.2V$ or CE2 ≤ 0.2V V _{IN} ≥ V _{DD} - 0.2V, or V _{IN} ≤ V _{SS} + 0.2V	Com. Ind. Auto.	— 200 —	400 — 500	μA
t _{SDR}	Data Retention Setup Time	See Data Retention Waveform	0		—	ns
t _{RDR}	Recovery Time	See Data Retention Waveform	t _{RC}		—	ns

Note:

1. Typical Values are measured at V_{DD} = 5V, T_A = 25°C and not 100% tested.

DATA RETENTION WAVEFORM ($\overline{CE1}$ Controlled)

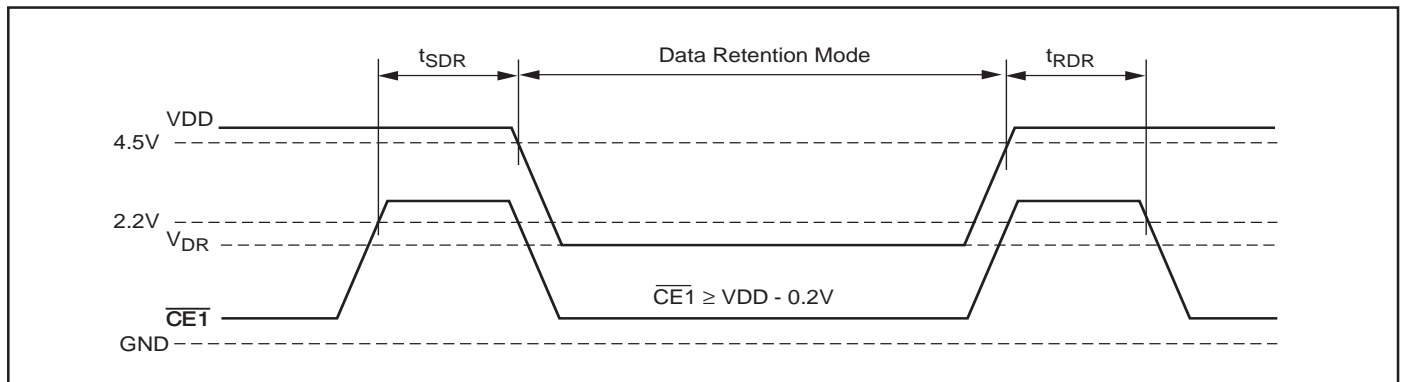

DATA RETENTION WAVEFORM (CE2 Controlled)

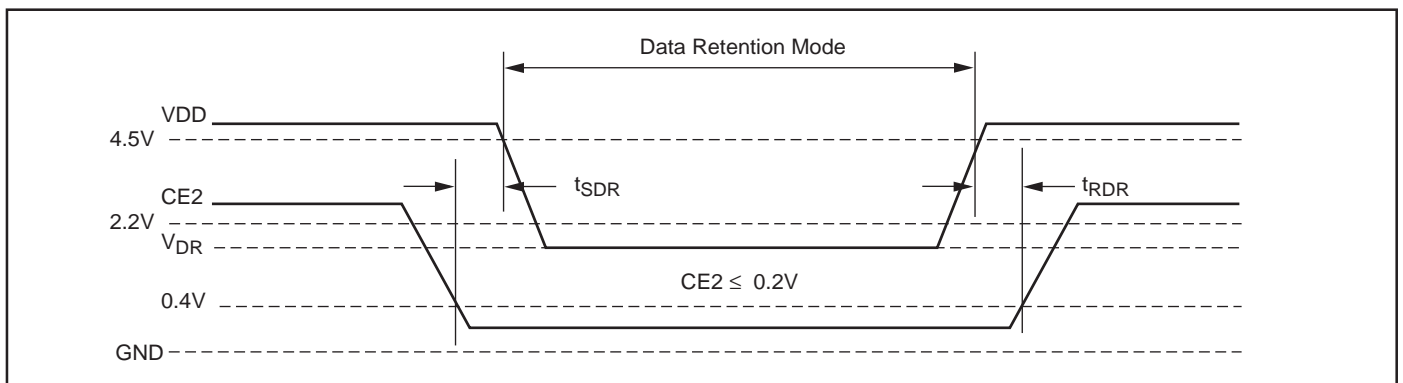

IS61C1024AL, IS64C1024AL

ORDERING INFORMATION: IS61C1024AL

Commercial Range: 0°C to +70°C

Speed (ns)	Order Part No.	Package
12	IS61C1024AL-12J	300-mil Plastic SOJ
	IS61C1024AL-12T	TSOP (Type I)

ORDERING INFORMATION: IS61C1024AL

Industrial Range: -40°C to +85°C

Speed (ns)	Order Part No.	Package
12	IS61C1024AL-12JI	300-mil Plastic SOJ
	IS61C1024AL-12JLI	300-mil Plastic SOJ, Lead-free
	IS61C1024AL-12KI	400-mil Plastic SOJ
	IS61C1024AL-12KLI	400-mil Plastic SOJ, Lead-free
	IS61C1024AL-12HI	sTSOP (Type I)
	IS61C1024AL-12TI	TSOP (Type I)
	IS61C1024AL-12TLI	TSOP (Type I), Lead-free

ORDERING INFORMATION: IS64C1024AL

Automotive Range: -40°C to +125°C

Speed (ns)	Order Part No.	Package
15	IS64C1024AL-15KA3	400-mil Plastic SOJ
	IS64C1024AL-15TA3	TSOP (Type I)

PACKAGING INFORMATION

Plastic STSOP - 32 pins
 Package Code: H (Type I)

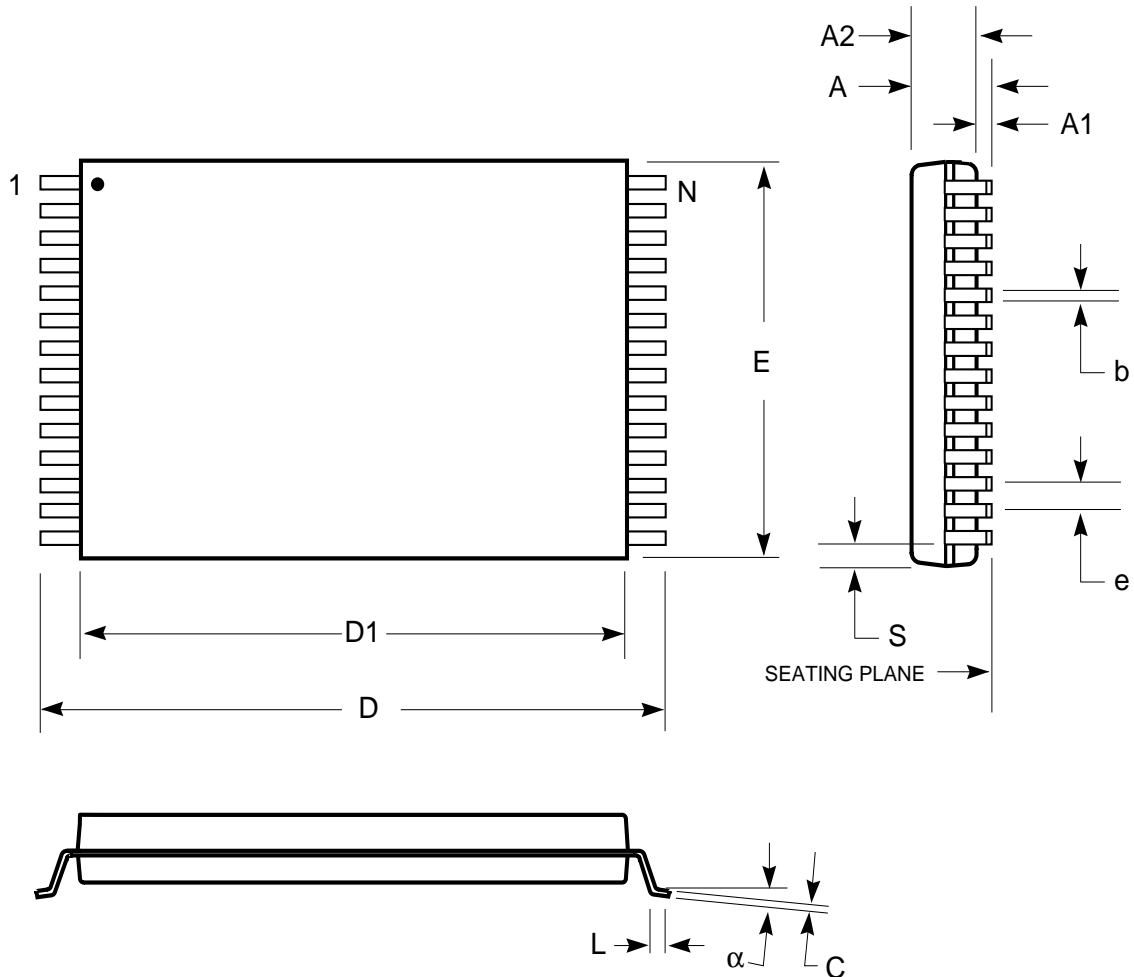

Plastic STSOP (H - Type I)				
	Millimeters		Inches	
Symbol	Min	Max	Min	Max
Ref. Std.				
N	32			
A	—	1.25	—	0.049
A1	0.05	—	0.002	—
A2	0.95	1.05	0.037	0.041
b	0.17	0.23	0.007	0.009
C	0.14	0.16	0.0055	0.0063
D	13.20	13.60	0.520	0.535
D1	11.70	11.90	0.461	0.469
E	7.90	8.10	0.311	0.319
e	0.50 BSC		0.020 BSC	
L	0.30	0.70	0.012	0.028
S	0.28 Typ.		0.011 Typ.	
alpha	0°	5°	0°	5°

Notes:

1. Controlling dimension: millimeters, unless otherwise specified.
2. BSC = Basic lead spacing between centers.
3. Dimensions D1 and E do not include mold flash protrusions and should be measured from the bottom of the package.
4. Formed leads shall be planar with respect to one another within 0.004 inches at the seating plane.

PACKAGING INFORMATION

400-mil Plastic SOJ

Package Code: K

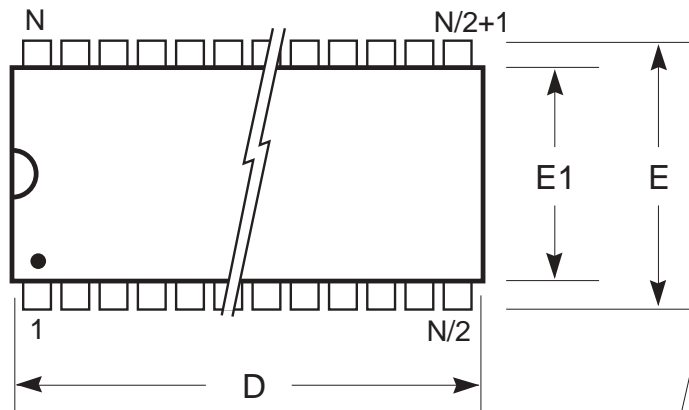

Notes:

1. Controlling dimension: millimeters.
2. BSC = Basic lead spacing between centers.
3. Dimensions D and E1 do not include mold flash protrusions and should be measured from the bottom of the package.
4. Reference document: JEDEC MS-027.

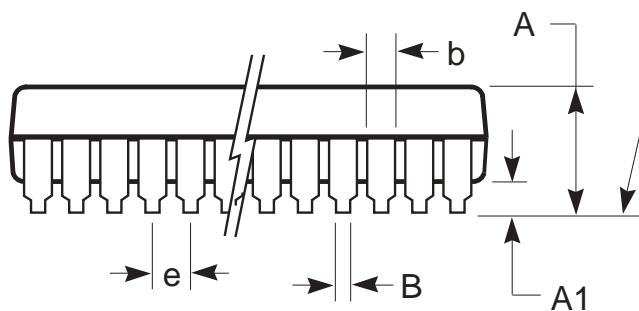

SEATING PLANE

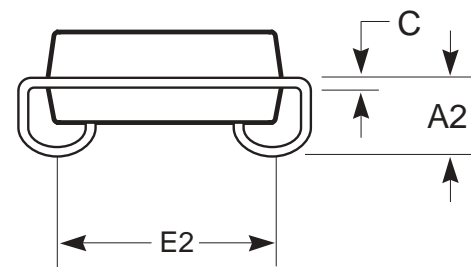

Symbol	Millimeters		Inches		Millimeters		Inches		Millimeters		Inches	
	Min	Max	Min	Max	Min	Max	Min	Max	Min	Max	Min	Max
No. Leads (N)	28				32				36			
A	3.25	3.75	0.128	0.148	3.25	3.75	0.128	0.148	3.25	3.75	0.128	0.148
A1	0.64	—	0.025	—	0.64	—	0.025	—	0.64	—	0.025	—
A2	2.08	—	0.082	—	2.08	—	0.082	—	2.08	—	0.082	—
B	0.38	0.51	0.015	0.020	0.38	0.51	0.015	0.020	0.38	0.51	0.015	0.020
b	0.66	0.81	0.026	0.032	0.66	0.81	0.026	0.032	0.66	0.81	0.026	0.032
C	0.18	0.33	0.007	0.013	0.18	0.33	0.007	0.013	0.18	0.33	0.007	0.013
D	18.29	18.54	0.720	0.730	20.82	21.08	0.820	0.830	23.37	23.62	0.920	0.930
E	11.05	11.30	0.435	0.445	11.05	11.30	0.435	0.445	11.05	11.30	0.435	0.445
E1	10.03	10.29	0.395	0.405	10.03	10.29	0.395	0.405	10.03	10.29	0.395	0.405
E2	9.40 BSC		0.370 BSC		9.40 BSC		0.370 BSC		9.40 BSC		0.370 BSC	
e	1.27 BSC		0.050 BSC		1.27 BSC		0.050 BSC		1.27 BSC		0.050 BSC	

Copyright © 2003 Integrated Silicon Solution, Inc. All rights reserved. ISSI reserves the right to make changes to this specification and its products at any time without notice. ISSI assumes no liability arising out of the application or use of any information, products or services described herein. Customers are advised to obtain the latest version of this device specification before relying on any published information and before placing orders for products.

Integrated Silicon Solution, Inc. — www.issi.com — 1-800-379-4774

Rev. F
10/29/03

PACKAGING INFORMATION



Symbol	Millimeters		Inches		Millimeters		Inches		Millimeters		Inches	
	Min	Max	Min	Max	Min	Max	Min	Max	Min	Max	Min	Max
No. Leads (N)	40				42				44			
A	3.25	3.75	0.128	0.148	3.25	3.75	0.128	0.148	3.25	3.75	0.128	0.148
A1	0.64	—	0.025	—	0.64	—	0.025	—	0.64	—	0.025	—
A2	2.08	—	0.082	—	2.08	—	0.082	—	2.08	—	0.082	—
B	0.38	0.51	0.015	0.020	0.38	0.51	0.015	0.020	0.38	0.51	0.015	0.020
b	0.66	0.81	0.026	0.032	0.66	0.81	0.026	0.032	0.66	0.81	0.026	0.032
C	0.18	0.33	0.007	0.013	0.18	0.33	0.007	0.013	0.18	0.33	0.007	0.013
D	25.91	26.16	1.020	1.030	27.18	27.43	1.070	1.080	28.45	28.70	1.120	1.130
E	11.05	11.30	0.435	0.445	11.05	11.30	0.435	0.445	11.05	11.30	0.435	0.445
E1	10.03	10.29	0.395	0.405	10.03	10.29	0.395	0.405	10.03	10.29	0.395	0.405
E2	9.40 BSC		0.370 BSC		9.40 BSC		0.370 BSC		9.40 BSC		0.370 BSC	
e	1.27 BSC		0.050 BSC		1.27 BSC		0.050 BSC		1.27 BSC		0.050 BSC	

Copyright © 2003 Integrated Silicon Solution, Inc. All rights reserved. ISSI reserves the right to make changes to this specification and its products at any time without notice. ISSI assumes no liability arising out of the application or use of any information, products or services described herein. Customers are advised to obtain the latest version of this device specification before relying on any published information and before placing orders for products.

PACKAGING INFORMATION



300-mil Plastic SOJ
Package Code: J

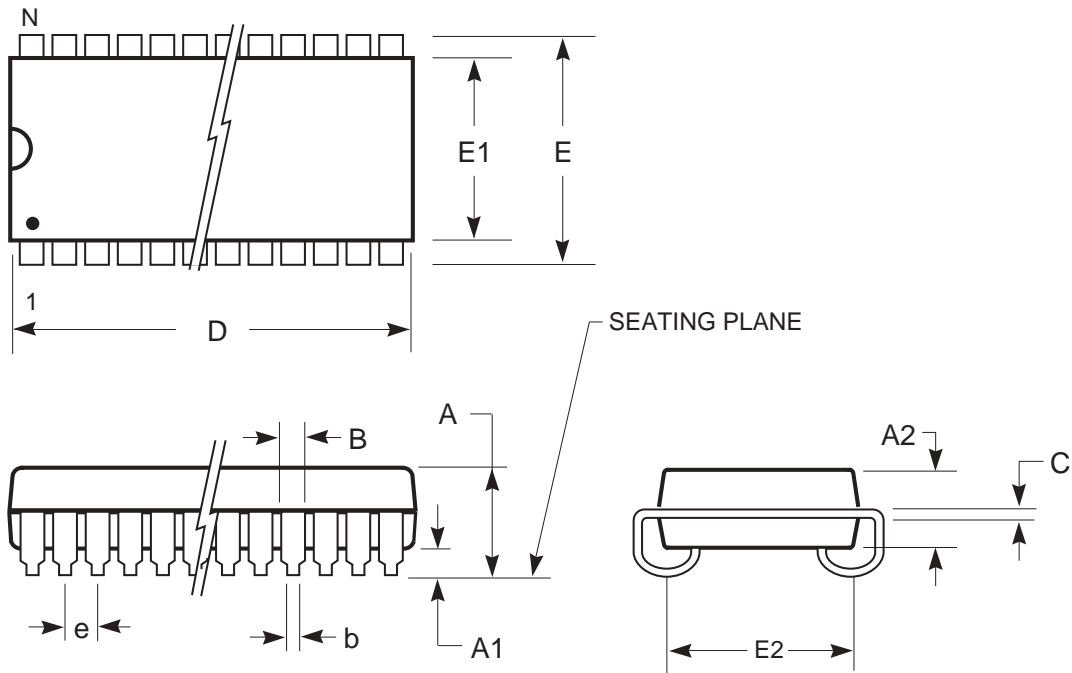

	MILLIMETERS			INCHES		
Sym.	Min.	Typ.	Max.	Min.	Typ.	Max.
N0.						
Leads	24/26					
A	—	—	3.56	—	—	0.140
A1	0.64	—	—	0.025	—	—
A2	2.41	—	2.67	0.095	—	0.105
b	0.41	—	0.51	0.016	—	0.020
B	0.66	—	0.81	0.026	—	0.032
C	0.20	—	0.25	0.008	—	0.010
D	17.02	—	17.27	0.670	—	0.680
E	8.26	—	8.76	0.325	—	0.345
E1	7.49	—	7.75	0.295	—	0.305
E2	6.27	—	7.29	0.247	—	0.287
e	1.27 BSC			0.050 BSC		

Notes:

1. Controlling dimension: inches, unless otherwise specified.
2. BSC = Basic lead spacing between centers.
3. Dimensions D and E1 do not include mold flash protrusions and should be measured from the bottom of the package.
4. Formed leads shall be planar with respect to one another within 0.004 inches at the seating plane.

Copyright © 2003 Integrated Silicon Solution, Inc. All rights reserved. ISSI reserves the right to make changes to this specification and its products at any time without notice. ISSI assumes no liability arising out of the application or use of any information, products or services described herein. Customers are advised to obtain the latest version of this device specification before relying on any published information and before placing orders for products.

Integrated Silicon Solution, Inc. — www.issi.com — 1-800-379-4774

Rev. D
 02/25/03

PACKAGING INFORMATION



300-mil Plastic SOJ
 Package Code: J

MILLIMETERS				INCHES		
Sym.	Min.	Typ.	Max.	Min.	Typ.	Max.
NO. Leads				28		
A	—	—	3.56	—	—	0.140
A1	0.64	—	—	0.025	—	—
A2	2.41	—	2.67	0.095	—	0.105
b	0.41	—	0.51	0.016	—	0.020
B	0.66	—	0.81	0.026	—	0.032
C	0.20	—	0.25	0.008	—	0.010
D	18.29	—	18.54	0.720	—	0.730
E	8.26	—	8.76	0.325	—	0.345
E1	7.49	—	7.75	0.295	—	0.305
E2	6.27	—	7.29	0.247	—	0.287
e	1.27 BSC			0.050 BSC		

MILLIMETERS				INCHES		
Sym.	Min.	Typ.	Max.	Min.	Typ.	Max.
NO. Leads				32		
A	—	—	3.56	—	—	0.140
A1	0.64	—	—	0.025	—	—
A2	2.41	—	2.67	0.095	—	0.105
b	0.41	—	0.51	0.016	—	0.020
B	0.66	—	0.81	0.026	—	0.032
C	0.20	—	0.25	0.008	—	0.010
D	20.83	—	21.08	0.820	—	0.830
E	8.26	—	8.76	0.325	—	0.345
E1	7.49	—	7.75	0.295	—	0.305
E2	6.27	—	7.29	0.247	—	0.287
e	1.27 BSC			0.050 BSC		

PACKAGING INFORMATION

Plastic TSOP-Type I
 Package Code: T (32-pin)

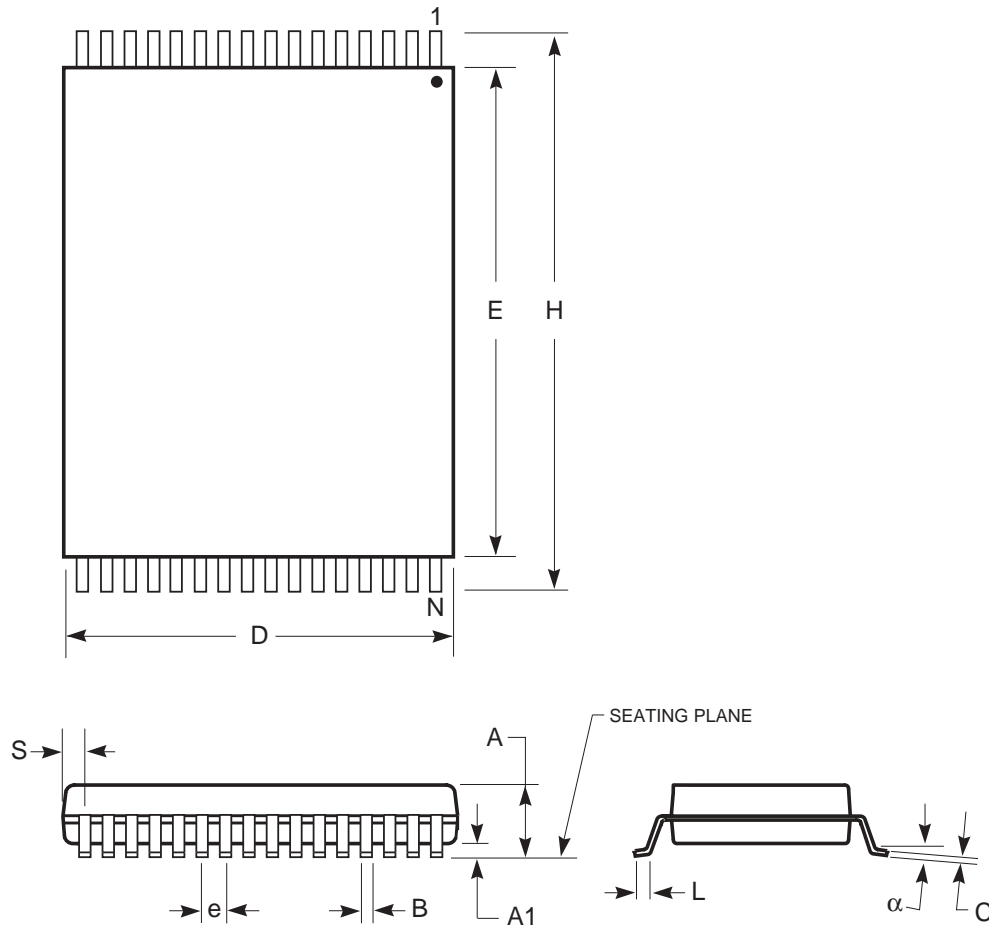

	MILLIMETERS		INCHES	
Symbol	Min.	Max.	Min.	Max.
No. Leads	32			
A	—	1.20	—	0.047
A1	0.05	0.25	0.002	0.010
B	0.17	0.23	0.007	0.009
C	0.12	0.17	0.005	0.007
D	7.90	8.10	0.311	0.319
E	18.30	18.50	0.720	0.728
H	19.80	20.20	0.780	0.795
e	0.50 BSC		0.020 BSC	
L	0.40	0.60	0.016	0.024
α	0°	8°	0°	8°
S	0.25 REF		0.010 REF	

Notes:

1. Controlling dimension: millimeters, unless otherwise specified.
2. BSC = Basic lead spacing between centers.
3. Dimensions D and E do not include mold flash protrusions and should be measured from the bottom of the package.
4. Formed leads shall be planar with respect to one another within 0.004 inches at the seating plane.

Copyright © 2003 Integrated Silicon Solution, Inc. All rights reserved. ISSI reserves the right to make changes to this specification and its products at any time without notice. ISSI assumes no liability arising out of the application or use of any information, products or services described herein. Customers are advised to obtain the latest version of this device specification before relying on any published information and before placing orders for products.