



# 4 ADC/8 DAC with PLL, 192 kHz, 24 Bit CODEC

Preliminary Technical Data

AD1935/AD1936/AD1937/AD1938/AD1939

## Features

PLL generated (32-192kHz) or direct master clock

Low EMI design

109 dB DAC/ 107dB ADC Dynamic Range and SNR  
-94dB THD+N

Single 3.3V Supply

Tolerance for 5V logic inputs

Supports 24-bits and 8 kHz - 192 kHz sample rates

Differential ADC input

Single-ended or Differential DAC output versions

Log volume control with "auto-ramp" function

Hardware and software controllable clickless mute

Software and hardware power-down

Right justified, left justified, I<sup>2</sup>S and TDM Modes

Master and slave modes up to 16 channel in/out

48-lead LQFP or 64-lead LQFP plastic package

## Applications

Automotive audio systems

Home theater systems

Set-top boxes

Digital audio effects processors

## GENERAL DESCRIPTION

The AD193X family are high performance, single-chip codecs that provide 4 ADCs with differential input and 8 DACs with either single-ended or differential output using ADI's patented multibit sigma-delta architecture. An SPI<sup>®</sup> or I<sup>2</sup>C<sup>®</sup> port is included, allowing a microcontroller to adjust volume and many other parameters. The AD193X family operates from 3.3V digital and analog supplies. The AD193X is available in a 48-lead (SE output) or 64-lead (differential output) LQFP package.

The AD193X is designed for low EMI. This consideration is apparent in both the system and circuit design architectures. By using the on-board PLL to derive master clock from L-R clock, the AD193X eliminates the need for a separate high frequency master clock. It can also be used with a suppressed bit clock. The D-A and A-D converters are designed using the latest ADI continuous time architectures to further minimize EMI. By using 3.3V supplies, power consumption is minimized, further reducing emissions.

## Functional Block Diagram

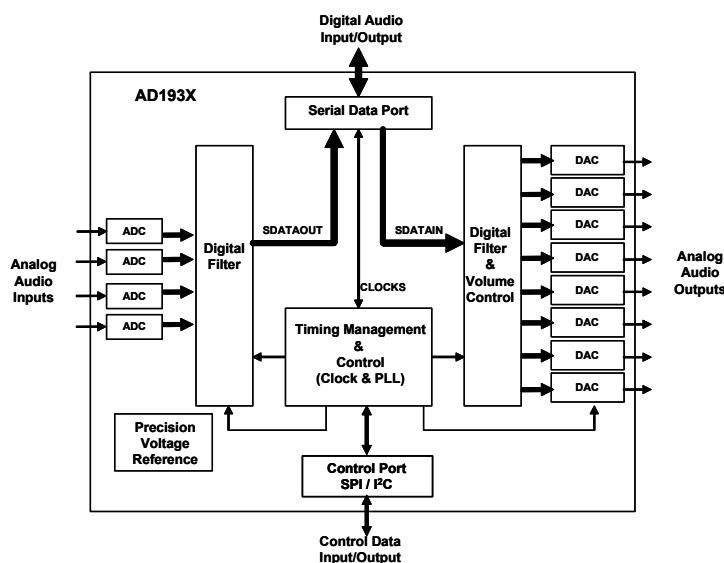

Figure 1

## Rev. PrI

Information furnished by Analog Devices is believed to be accurate and reliable. However, no responsibility is assumed by Analog Devices for its use, nor for any infringements of patents or other rights of third parties that may result from its use. Specifications subject to change without notice. No license is granted by implication or otherwise under any patent or patent rights of Analog Devices. Trademarks and registered trademarks are the property of their respective companies.

One Technology Way, P.O. Box 9106, Norwood, MA 02062-9106, U.S.A.  
Tel: 781.329.4700 www.analog.com  
Fax: 781.326.8703 © 2005 Analog Devices, Inc. All rights reserved.

## AD193X—SPECIFICATIONS

## Test Conditions, Unless Otherwise Noted.

Performance of all channels is identical (exclusive of the Inter-channel Gain Mismatch and Inter-channel Phase Deviation specifications).

Parameter	Rating
Supply Voltages (AVDD, DVDD)	3.3 V
Case Temperature	25°C
Master Clock	12.288 MHz (48 kHz $f_s$ , $256 \times f_s$ Mode)
Input Signal	1.000 kHz, 0 dBFS (Full Scale), -1 dBVrms (0.9Vrms)
Input Sample Rate	48 kHz
Measurement Bandwidth	20 Hz to 20 kHz
Word Width	24 Bits
Load Capacitance (Digital Output)	50 pF
Load Current (Digital Output)	$\pm 1$ mA or $1.5k\Omega$ to $\frac{1}{2}$ DVDD supply
Input Voltage HI	2.0 V
Input Voltage LO	0.8 V

Table 1

## Analog Performance

Parameter	Min	Typ	Max	Unit	
ANALOG-TO-DIGITAL CONVERTERS	ADC Resolution (all ADCs)		24	Bits	
	Dynamic Range (20 Hz to 20 kHz, -60 dB Input) <sup>1</sup>				
	No Filter (RMS)		102		dB
	With A-Weighted Filter (RMS)		105		dB
	With A-Weighted Filter (Avg)		107		dB
	Total Harmonic Distortion + Noise (-1 dBFS) <sup>1</sup>		-92		dB
	Full-Scale Input Voltage (Differential)		1.9		V rms
	Gain Error	-5.0		+5.0	%
	Interchannel Gain Mismatch	-0.1		+0.1	dB
	Offset Error	-10	0	+10	mV
	Gain Drift		100		ppm/°C
	Interchannel Isolation		-110		dB
	CMRR, 100 mV RMS, 1 kHz		70		dB
	CMRR, 100 mV RMS, 20 kHz		70		dB
	Input Resistance		14		k $\Omega$
	Input Capacitance		10		pF
Input Common-Mode Bias Voltage		1.5		V	
DIGITAL-TO-ANALOG CONVERTERS	Dynamic Range (20 Hz to 20 kHz, -60 dB Input) <sup>1</sup>				
	No Filter (RMS), Single-ended version		101		dB
	With A-Weighted Filter (RMS), Single-ended version		104		dB
	With A-Weighted Filter (Avg), Single-ended version		106		dB
	No Filter (RMS), Differential version		104		dB
	With A-Weighted Filter (RMS), Differential version		107		dB
	With A-Weighted Filter (Avg), Differential version		109		dB
	Total Harmonic Distortion + Noise (0 dBFS) <sup>1</sup>				
	Single-ended version		-92		dB
	Differential version		-94		dB
	Full-Scale Output Voltage (Single-ended version)		0.9 (2.5)		V rms (V pp)
	Full-Scale Output Voltage (Differential version)		1.8 (5.0)		V rms (V pp)
Gain Error	-6%	TBD	+6%	%	

<sup>1</sup>Total harmonic distortion + noise and dynamic range typical specifications are for two channels active, max/min are all channels active.

Parameter	Min	Typ	Max	Unit
Interchannel Gain Mismatch	-0.5		+0.5	dB
Offset Error, Single-ended version		-15		mV
Offset Error, Differential version		-10		mV
Gain Drift	-30		30	ppm/°C
Interchannel Isolation		100		dB
Interchannel Phase Deviation		0		Degrees
Volume Control Step		0.375		dB
Volume Control Range		95		dB
De-emphasis Gain Error			±0.6	dB
Output Resistance at Each Pin		100		Ω
REFERENCE		1.50		V
Internal Reference Voltage, FILTR		1.50		V
External Reference Voltage, FILTR	0.90	1.50	1.80	V
Common-Mode Reference Output, CM		1.50		V

Table 2

### Crystal Oscillator

Parameter	Min	Typ	Max	Unit
Transconductance		10		mmhos

Table 3

### Digital I/O

Parameter	Min	Typ	Max	Unit
Input Voltage HI (V <sub>IH</sub> )	2.0			V
Input Voltage LO (V <sub>IL</sub> )			0.8	V
Input Leakage (I <sub>IH</sub> @ V <sub>IH</sub> = 2.4 V)			10	μA
Input Leakage (I <sub>IL</sub> @ V <sub>IL</sub> = 0.8 V)			10	μA
High Level Output Voltage (V <sub>OH</sub> ) I <sub>OH</sub> = 4 mA	DVDD - 0.5			V
Low Level Output Voltage (V <sub>OL</sub> ) I <sub>OL</sub> = 4 mA			0.5	V
Input Capacitance			5	pF

Table 4

### Power Supplies

Parameter	Min	Typ	Max	Unit	
Supplies	Voltage, DVDD	3.0	3.3	3.6	V
	Voltage, AVDD	3.0	3.3	3.6	V
	Digital Current		56		mA
	Digital Current—Power-Down		TBD		mA
	Digital Current—Reset		TBD		mA
	Analog Current		74		mA
	Analog Current—Power-Down		TBD		mA
	Analog Current—Reset		TBD		mA
Dissipation	Operation—All Supplies		429		mW
	Operation—Digital Supply		185		mW
	Operation—Analog Supply		244		mW
	Power-Down—All Supplies		TBD		mW
Power Supply Rejection Ratio	1 kHz 200 mV p-p Signal at Analog Supply Pins		TBD		dB
	20 kHz 200 mV p-p Signal at Analog Supply Pins		TBD		dB

Table 5

## Temperature Range

Parameter	Min	Typ	Max	Unit
Specifications Guaranteed		25		°C Case
Functionality Guaranteed	-40		+105	°C Ambient
	-40		+125	°C Case
Storage	-65		+150	°C

Table 6

## Digital Filters

	Mode	Parameter	Factor	Min	Typ	Max	Unit	
ADC DECIMATION FILTER	All Modes, Typ @ 48 kHz	Pass Band	0.4375 $f_s$		21		kHz	
		Pass-Band Ripple			±0.015		dB	
		Transition Band	0.5 $f_s$		24		kHz	
		Stop Band	0.5625 $f_s$		27		kHz	
		Stop-Band Attenuation		79			dB	
		Group Delay	22.9844/ $f_s$		479		μs	
DAC INTERPOLATION FILTER	48 kHz Mode, Typ @ 48 kHz	Pass Band	0.4535 $f_s$		22		kHz	
		Pass-Band Ripple				±0.01	dB	
		Transition Band	0.5 $f_s$		24		kHz	
		Stop Band	0.5465 $f_s$		26		kHz	
		Stop-Band Attenuation		70			dB	
		Group Delay	25/ $f_s$		521		μs	
	96 kHz Mode, Typ @ 96 kHz	Pass Band	0.3646 $f_s$		35		kHz	
		Pass-Band Ripple					±0.05	dB
		Transition Band	0.5 $f_s$		48		kHz	
		Stop Band	0.6354 $f_s$		61		kHz	
		Stop-Band Attenuation		70			dB	
		Group Delay	11/ $f_s$		115		μs	
	192 kHz Mode, Typ @ 192 kHz	Pass Band	0.3646 $f_s$		70		kHz	
		Pass-Band Ripple					±0.1	dB
		Transition Band	0.5 $f_s$		96		kHz	
		Stop Band	0.6354 $f_s$		122		kHz	
		Stop-Band Attenuation		70			dB	
		Group Delay	8/ $f_s$		42		μs	

Table 7

## Timing Specifications

Parameter		Comments	Min	Max	Unit	
MASTER CLOCK AND RESET	$t_{MH}$	MCLK High	PLL Mode	15		ns
	$t_{ML}$	MCLK Low	PLL Mode	15		ns
	$t_{MCLK}$	MCLK Period	PLL Mode, 256 $f_s$ reference	73	146	ns
	$f_{MCLK}$	MCLK Frequency	PLL Mode, 256 $f_s$ reference	6.9	13.8	MHz
	$t_{MH}$	MCLK High	Direct 512 $f_s$ Mode	15		ns
	$t_{ML}$	MCLK Low	Direct 512 $f_s$ Mode	15		ns
	$t_{MCLK}$	MCLK Period	Direct 512 $f_s$ Mode	36		ns
	$f_{MCLK}$	MCLK Frequency	Direct 512 $f_s$ Mode		27.6	MHz
	$t_{PDR}$	$\overline{PD/RST}$ Low		TBD		ns
	$t_{PDRR}$	$\overline{PD/RST}$ Recovery	Reset to Active Output	TBD		$t_{MCLK}$
SPI PORT	$t_{CCH}$	CCLK High		TBD	ns	
	$t_{CCL}$	CCLK Low		TBD	ns	
	$t_{CCP}$	CCLK Period		50	ns	

Parameter		Comments	Min	Max	Unit		
	f <sub>CCLK</sub>	CCLK Frequency		20	MHz		
	t <sub>CDS</sub>	CDATA Setup	To CCLK Rising	TBD	ns		
	t <sub>CDH</sub>	CDATA Hold	From CCLK Rising	TBD	ns		
	t <sub>CLS</sub>	CLATCH Setup	To CCLK Rising	TBD	ns		
	t <sub>CLH</sub>	CLATCH Hold	From CCLK Falling	TBD	ns		
	t <sub>CLH</sub>	CLATCH High		TBD	ns		
	t <sub>COE</sub>	COUT Enable	From CCLK Falling		TBD	ns	
	t <sub>COD</sub>	COUT Delay	From CCLK Falling		TBD	ns	
	t <sub>COH</sub>	COUT Hold	From CCLK Falling	TBD	ns		
	t <sub>COTS</sub>	COUT Three-State	From CCLK Falling		TBD	ns	
I <sup>2</sup> C PORT		f <sub>SCL</sub>	SCL Clock Frequency		400	kHz	
		t <sub>SCLH</sub>	SCL High	0.6		μs	
		t <sub>SCLL</sub>	SCL Low	1.3		μs	
	Start Condition	t <sub>SCS</sub>	Setup Time	Relevant for Repeated Start Condition	0.6		μs
		t <sub>SCH</sub>	Hold Time	After this period the 1st clock is generated	0.6		μs
		t <sub>DS</sub>	Data Setup Time		100		ns
		t <sub>SCR</sub>	SCL Rise Time			300	ns
		t <sub>SCF</sub>	SCL Fall Time			300	ns
		t <sub>SDR</sub>	SDA Rise Time			300	ns
	Stop Condition	t <sub>SDF</sub>	SDA Fall Time			300	ns
t <sub>SCS</sub>		Setup Time		0.6		μs	
DAC SERIAL PORT	Slave Mode	t <sub>DBH</sub>	DBCLK High		TBD	ns	
		t <sub>DBL</sub>	DBCLK Low		TBD	ns	
		f <sub>DB</sub>	DBCLK Frequency		TBD	ns	
	Master Mode	t <sub>DLS</sub>	DLRCLK Setup	To DBCLK Rising	TBD	ns	
		t <sub>DLH</sub>	DLRCLK Hold	From DBCLK Rising	TBD	ns	
		t <sub>DLS</sub>	DLRCLK Skew	From DBCLK Falling	TBD	TBD	ns
ADC SERIAL PORT	Slave Mode	t <sub>DDS</sub>	DSDATA Setup	To DBCLK Rising	TBD	ns	
		t <sub>DDH</sub>	DSDATA Hold	From DBCLK Rising	TBD	ns	
		t <sub>ABH</sub>	ABCLK High		TBD	ns	
	Master Mode	t <sub>ABL</sub>	ABCLK Low		TBD	ns	
		f <sub>DB</sub>	ABCLK Frequency		TBD	ns	
		t <sub>ALS</sub>	ALRCLK Setup	To ABCLK Rising	TBD	ns	
AUXILIARY INTERFACE		t <sub>ALH</sub>	ALRCLK Hold	From ABCLK Rising	TBD	ns	
		t <sub>ALS</sub>	ALRCLK Skew	From ABCLK Falling	TBD	TBD	ns
		t <sub>ABDD</sub>	ASDATA Delay	From ABCLK Falling		TBD	ns
	t <sub>AXDS</sub>	AAUXDATA Setup	To AUXBCLK Rising	TBD	ns		
	t <sub>AXDH</sub>	AAUXDATA Hold	From AUXBCLK Rising	TBD	ns		
	t <sub>DXDD</sub>	DAUXDATA Delay	From AUXBCLK Falling		TBD	ns	
	t <sub>XBH</sub>	AUXBCLK High		TBD	ns		
t <sub>XBL</sub>	AUXBCLK Low		TBD	ns			
f <sub>XB</sub>	AUXBCLK Frequency		TBD	ns			
	t <sub>DLS</sub>	AUXLRCLK Setup	To AUXBCLK Rising	TBD	ns		
	t <sub>DLH</sub>	AUXLRCLK Hold	From AUXBCLK Rising	TBD	ns		

Table 8

## ABSOLUTE MAXIMUM RATINGS

Parameter	Min	Max	Unit
Analog (AVDD)	-0.3	+3.6	V
Digital (DVDD)	-0.3	+3.6	V
Input Current (Except Supply Pins)		±20	mA
Analog Input Voltage (Signal Pins)	-0.3	AVDD + 0.3	V
Digital Input Voltage (Signal Pins)	-0.3	DVDD + 0.3	V
Case Temperature (Operating)	-40	+125	°C

Table 9

Stresses above those listed under the Absolute Maximum Ratings may cause permanent damage to the device. This is a stress rating only; functional operation of the device at these or any other conditions above those indicated in the operational section of this specification is not implied. Exposure to absolute maximum rating conditions for extended periods may affect device reliability.

## Package Characteristics

Parameter	Min	Typ	Max	Unit
$\theta_{JA}$ (Thermal Resistance [Junction to Ambient]), 48-lead LQFP		50.1		°C/W
$\theta_{JC}$ (Thermal Resistance [Junction to Case]), 48-lead LQFP		17		°C/W
$\theta_{JA}$ (Thermal Resistance [Junction to Ambient]), 64-lead LQFP		47		°C/W
$\theta_{JC}$ (Thermal Resistance [Junction to Case]), 64-lead LQFP		11.1		°C/W

Note: Characteristics are for a 4-layer board

Table 10

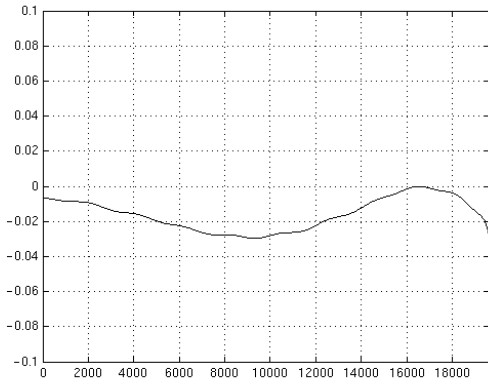

Figure 2. ADC Passband Filter Response, 48 kHz

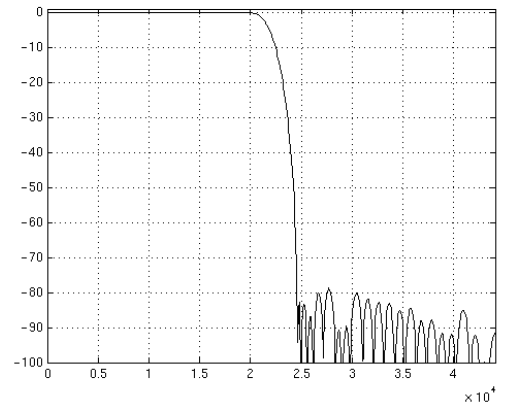

Figure 3. ADC Stopband Filter Response, 48 kHz

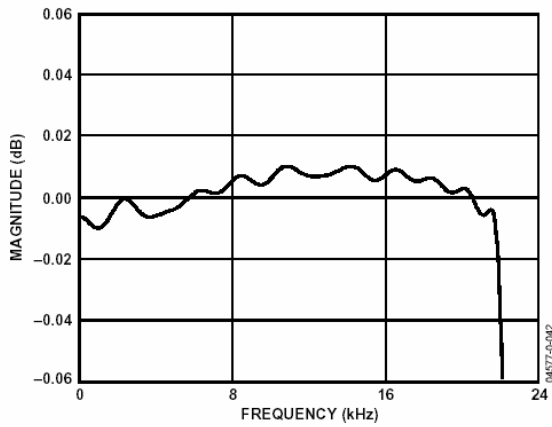

Figure 4. DAC Passband Filter Response, 48 kHz

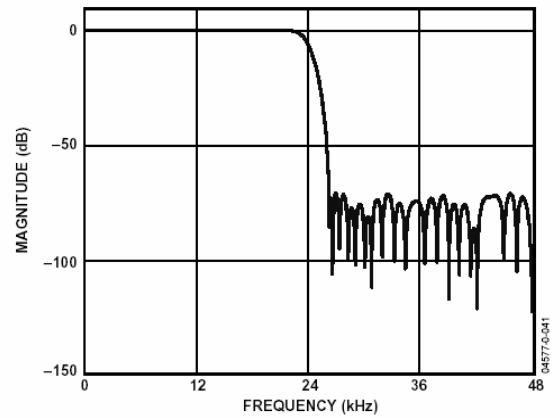

Figure 5. DAC Stopband Filter Response, 48 kHz

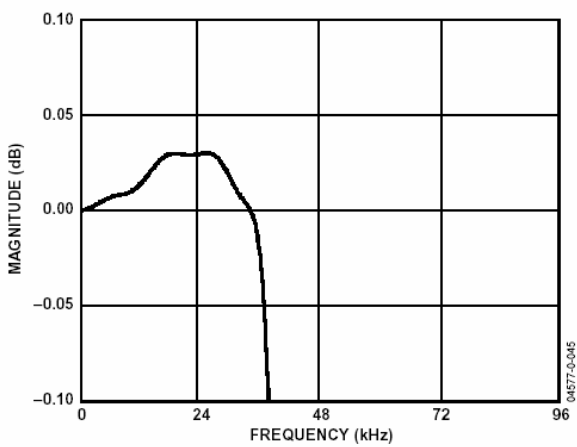

Figure 6. DAC Passband Filter Response, 96 kHz

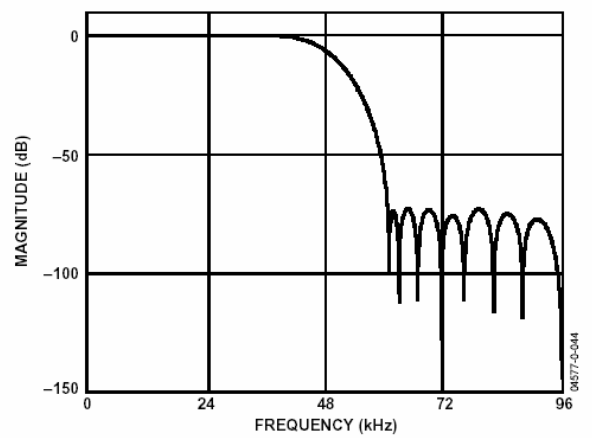

Figure 7. DAC Stopband Filter Response, 96 kHz

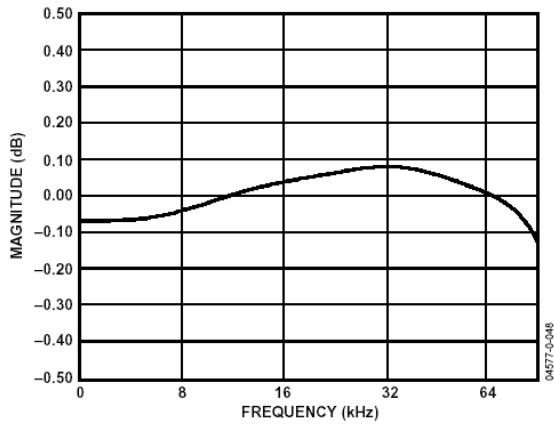

Figure 8. DAC Passband Filter Response, 192 kHz

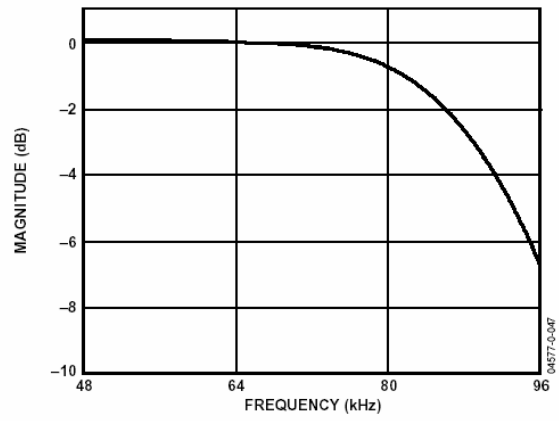

Figure 9. DAC Stopband Filter Response, 192 kHz



## FUNCTIONAL OVERVIEW

### ADCs

There are four ADC channels in the AD193X configured as two stereo pairs with differential inputs. The ADCs can operate at a nominal sample rate of 48, 96, or 192 kHz. The ADCs include on-board digital anti-aliasing filters with 79 dB stop-band attenuation and linear phase response, operating at an oversampling ratio of 128 (48 kHz, 96 kHz, and 192 kHz modes). Digital outputs are supplied through two serial data output pins (one for each stereo pair) and a common frame (ALRCLK) and bit (ABCLK) clock. Alternatively, one of the TDM modes may be used to access up to 16 channels on a single TDM data line.

The ADCs must be driven from a differential signal source for best performance. The input pins of the ADCs connect to internal switched capacitors. To isolate the external driving op amp from the “glitches” caused by the internal switched capacitors, each input pin should be isolated by using a series-connected external 100  $\Omega$  resistor together with a 1 nF capacitor connected from each input to ground. This capacitor must be of high quality; for example, ceramic NPO or polypropylene film.

The differential inputs have a nominal common-mode voltage of 1.5V. The voltage at the common-mode reference pin, CM can be used to bias external op amps to buffer the input signals (see the Power Supply and Voltage Reference section). The inputs can also be AC coupled and do not need an external DC bias to CM.

A digital high-pass filter can be switched in line with the ADCs under serial control to remove residual dc offsets. It has a 1.4 Hz, 6 dB per octave cutoff at a 48 kHz sample rate. The cutoff frequency will scale directly with sample frequency.

### DACs

The AD193X DAC channels are arranged as four stereo pairs giving eight analog outputs, either single-ended for minimum external components or differential for improved noise and distortion performance. The DACs include on-board digital reconstruction filters with 70 dB stop-band attenuation and linear phase response, operating at an oversampling ratio of 4 (48 kHz or 96 kHz modes) or 2 (192 kHz mode). Each channel has its own independently programmable attenuator, adjustable in 255 0.375 dB steps. Digital inputs are supplied through four serial data input pins (one for each stereo pair) and a common frame (DLRCLK) and bit (DBCLK) clock. Alternatively, one of the TDM modes may be used to access up to 16 channels on a single TDM data line.

Each output pin has a nominal common-mode dc level of 1.5V and swings  $\pm 1.27$  V for a 0 dBFS digital input signal. A single op amp third order external low-pass filter is recommended to remove high frequency noise present on the output pins, as well as to provide differential-to-single-ended conversion in the case of the differential output part. Note that the use of op amps with low slew

rate or low bandwidth may cause high frequency noise and tones to fold down into the audio band; care should be exercised in selecting these components.

The voltage at the common-mode reference pin, CM can be used to bias the external op amps that buffer the output signals (see the Power Supply and Voltage Reference section).

### Clock Signals

The on-chip Phase Locked Loop (PLL) can be selected to use as its reference the input sample rate from either of the LRCLK pins or 256, 384, 512, or 768 times the sample rate, referenced to 48kHz mode, from the MCLKI pin. The default at power-up is  $256 \times f_s$  from MCLKI. In 96 kHz mode, the master clock frequency will stay at the same absolute frequency so the actual multiplication rate will be divided by 2. In 192 kHz mode, the actual multiplication rate will be divided by 4. For example, if the AD193X is programmed in  $256 \times f_s$  mode, the frequency of the master clock input would be  $256 \times 48 \text{ kHz} = 12.288 \text{ MHz}$ . If the AD193X is then switched to 96 kHz operation (by writing to the SPI or I<sup>2</sup>C port), the frequency of the master clock should remain at 12.288 MHz, which is now  $128 \times f_s$ . In 192kHz mode, this would be  $64 \times f_s$ .

The internal clock for the ADCs is  $256 \times f_s$  for all clock modes. The internal clock for the DACs is  $512 \times f_s$  (48 kHz mode),  $256 \times f_s$  (96 kHz mode), or  $128 \times f_s$  (192 kHz mode). By default, the on-board PLL is used to generate this internal master clock from an external clock. A direct  $512 \times f_s$  (referenced to 48 kHz mode) master clock can be used for either the ADCs or DACs if selected in PLL and Clock Control Register 1.

Note that it is not possible to use a direct clock for the ADCs set to 192kHz mode. It is required that the on-chip PLL be used in this mode.

The PLL can be powered down in PLL and Clock Control Register 0. To ensure reliable locking when changing PLL modes or if the reference clock may be unstable at power-on, the PLL should be powered down and then powered back up when the reference clock is stable.

The internal MCLK can be disabled in PLL and Clock Control Register 0 to reduce power dissipation when the AD193X is idle. The clock should be stable before it is enabled. Unless a stand-alone mode is selected (see **Serial Control Port**), the clock is disabled by reset and must be enabled by writing to the SPI or I<sup>2</sup>C port for normal operation.

To maintain the highest performance possible, it is recommended that the clock jitter of the internal master clock signal be limited to less than 300 ps rms TIE (time interval error). Even at these levels, extra noise or tones may appear in the DAC outputs if the jitter spectrum contains large spectral peaks. If the internal PLL is not being used, it is highly recommended that an independent crystal

oscillator generate the master clock. In addition, it is especially important that the clock signal should not be passed through an FPGA, CPLD, or other large digital chip (such as a DSP) before being applied to the AD193X. In most cases, this will induce clock jitter due to the sharing of common power and ground connections with other unrelated digital output signals. When the PLL is used, jitter in the reference clock will be attenuated above a certain frequency depending on the loop filter.

## Reset and Power-Down

Reset will set all the control registers to their default settings. To avoid pops, reset does not power down the analog outputs. After reset is de-asserted, an initialization routine will run inside the AD193X. This initialization lasts for approximately XX MCLKs.

The power-down bits in the PLL and Clock Control 0, DAC Control 1, and ADC Control 1 registers will power down the respective sections. All other register settings are retained.

## Serial Control Port

The AD193X has an SPI or I<sup>2</sup>C compatible control port that

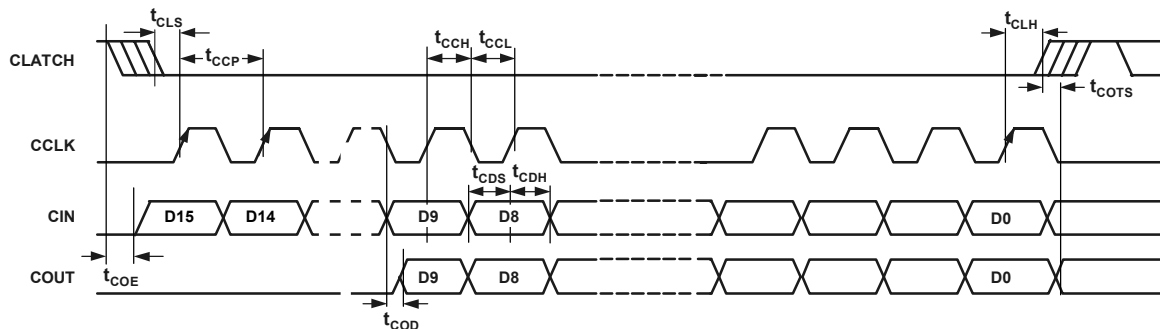

Figure 10. Format of SPI Signal

The I<sup>2</sup>C interface of the AD1936 and AD1937 is a two wire interface consisting of a clock line, SCL and a data line, SDA. SDA is bidirectional and the AD1936 and AD1937 will drive SDA either to acknowledge the master, ACK, or to send data during a read operation. The SDA pin for the I<sup>2</sup>C port is an open drain collector and requires a 1K $\Omega$  pullup resistor. A write or read access occurs when the SDA line is pulled low while the SCL line is high indicated by START in the timing diagrams. SDA is only allowed to change when SCL is low except when a START or STOP condition occurs as shown in figures 3 and 4. The first eight bits of the access consist of the device address and the R/W bit. The device address consists of an internal built-in address (0x04) and two address pins, AD1 and AD0. The two address pins allow up to four AD1936s and AD1937s to be used in a system. Initiating a write operation to the AD1936 and AD1937 involves sending a START condition and then sending the device address with the R/W set low. The AD1936 and AD1937 will respond by issuing an ACK to indicate that it has been addressed. The user then sends a second frame telling the

permits programming and reading back the internal control registers for the ADCs, DACs, and clock system. There is also a stand-alone mode available for operation without serial control, configured at reset using the serial control pins. All registers are set to default except Internal MCLK Enable is set to 1 and ADC BCLK and LRCLK Master/Slave is set by COUT/SDA. Refer to Table 10 for details.

ADC Clocks:	CIN/ADR0	COUT/SDA	CCLK/SCL	CLATCH/ADR1
Slave	0	0	0	0
Master	0	1	0	0

Table 11. Stand-alone Mode Selection

The SPI control port of the AD1938 and AD1939 is a 4-wire serial control port. The format is similar to the Motorola SPI format except the input data-word is 24 bits wide. The serial bit clock and latch may be completely asynchronous to the sample rate of the ADCs and DACs. Figure 10 shows the format of the SPI signal. The first byte is a global address with a read/write bit. For the AD193X the address is 0x04, shifted left 1 bit due to the R/ $\overline{W}$  bit. The second byte is the AD193X register address and the third byte is the data.

AD1936 and AD1937 which register is required to be written to. Another ACK is issued by the AD1936 and AD1937. Finally the user can send another frame with the 8 data bits required to be written to the register. A third ACK is issued by the AD1936 and AD1937 after which the user can send a STOP condition to complete the data transfer.

A read operation requires that the user first write to the AD1936 and AD1937 to point to the correct register and then read the data. This is achieved by sending a START condition followed by the device address frame, with R/W low, and then the register address frame. Following the ACK from the AD1936 and AD1937 the user must issue a REPEATED START condition. This is identical to a START condition. The next frame is the device address with R/W set high. On the next frame the AD1936 and AD1937 will output the register data on the SDA line. A STOP condition completes the read operation. Figure 3 and Figure 4 show examples of writing to and reading from the DAC 1 Left Volume Register (address = 0x06)

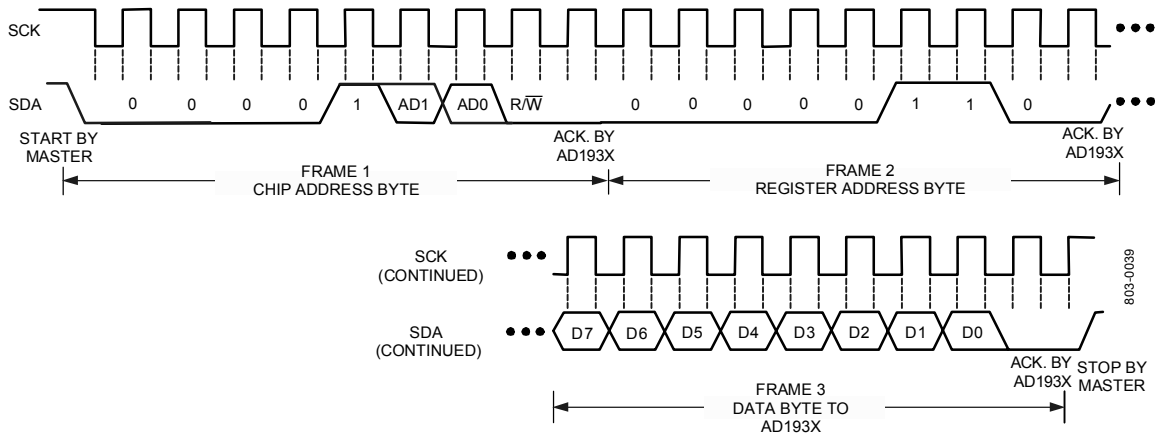

Figure 11. Format of I<sup>2</sup>C Write

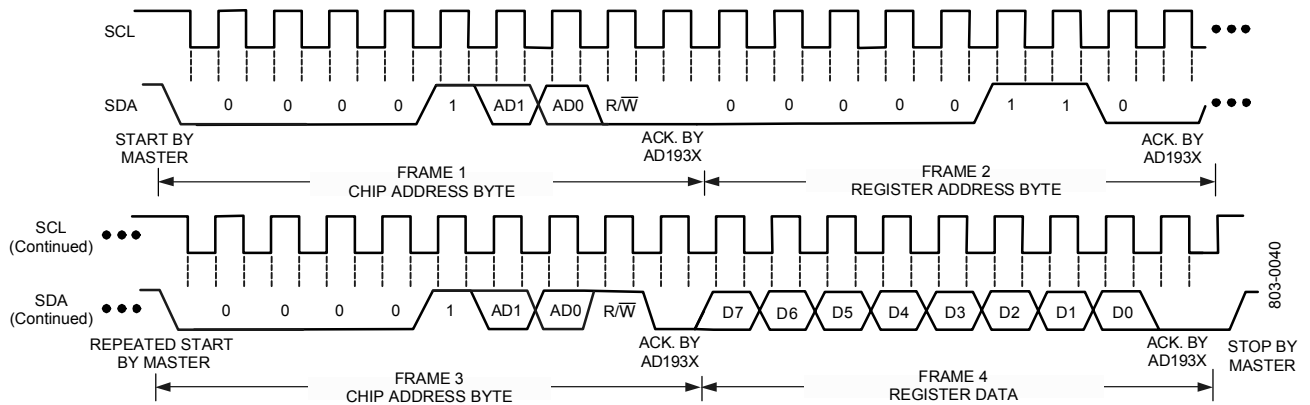

Figure 12. Format of I<sup>2</sup>C Read

## Power Supply and Voltage Reference

The AD193X is designed for 3.3 V supplies. Separate power supply pins are provided for the analog and digital sections. These pins should be bypassed with 100 nF ceramic chip capacitors, as close to the pins as possible, to minimize noise pickup. A bulk aluminum electrolytic capacitor of at least 22  $\mu$ F should also be provided on the same PC board as the codec. For critical applications, improved performance will be obtained with separate supplies for the analog and digital sections. If this is not possible, it is recommended that the analog and digital supplies be isolated by means of a ferrite bead in series with each supply. It is important that the analog supply be as clean as possible.

The AD1935 (64-pin single-ended version), and the AD1939 and AD1937 (64-pin differential versions) include a 3.3V regulator driver which requires only an external pass transistor and bypass capacitors to make a 5V to 3.3V regulator. If the regulator driver is not used, VSUPPLY, VDRIVE, and VSENSE should be connected to DGND.

All digital inputs are compatible with TTL and CMOS levels. All

outputs are driven from the 3.3 V DVDD supply and are compatible with TTL and 3.3 V CMOS levels.

The ADC and DAC internal voltage reference  $V_{REF}$  is brought out on FILTR and should be bypassed as close as possible to the chip, with a parallel combination of 10  $\mu$ F and 100 nF. Any external current drawn should be limited to less than 50  $\mu$ A.

The internal reference can be disabled in PLL and Clock Control Register 1 and FILTR driven from an external source. This can be used to scale the DAC output to a power amplifier's clipping level based on its power supply voltage. The ADC input gain will also vary by the inverse ratio. The total gain from ADC input to DAC output will stay constant.

The CM pin is the internal common-mode reference. It should be bypassed as close as possible to the chip, with a parallel combination of 10  $\mu$ F and 100 nF. This voltage may be used to bias external op amps to the common-mode voltage of the input and output signal pins. The output current should be limited to less than 0.5 mA source and 2 mA sink.

**Serial Data Ports—Data Format**

The eight DAC channels output or accept a common serial bit clock and left-right framing clock to clock in the serial data. The four ADC channels output or accept a common serial bit clock and left-right framing clock to clock out the data. The clock signals are all synchronous with the sample rate. In the AUX Modes, set in ADC Control 1 and DAC Control 0, the DACs use the ADC serial bit clock and left-right clock as the DAC clock pins are used for the auxiliary ADC/DAC serial clocks.

The ADC and DAC serial data modes default to I<sup>2</sup>S. The ports can also be programmed for left-justified, right-justified and TDM modes. The word width is 24 bits by default and can be programmed for 16 or 20 bits. The normal TDM mode can be daisy-chained with a second AD193X and will support 16 channels

at 48 kHz, 8 channels at 96 kHz or 4 channels at 192 kHz. There is also a dual-line TDM mode to support 8 channels at 192 kHz.

The special auxiliary modes are provided to allow two external stereo ADCs and/or two external stereo DACs to be interfaced with the AD193X to provide up to 8 in/12 out operation or 2 AD193Xs to be chained for up to 16 in/16 out operation. These modes provide a glueless interface to a single SHARC serial port, allowing the DSP to access up to 16 channels of analog I/O. In these modes many pins are redefined, see table 10. See Figure 18 for details of these modes.

The following figures show the serial mode formats.

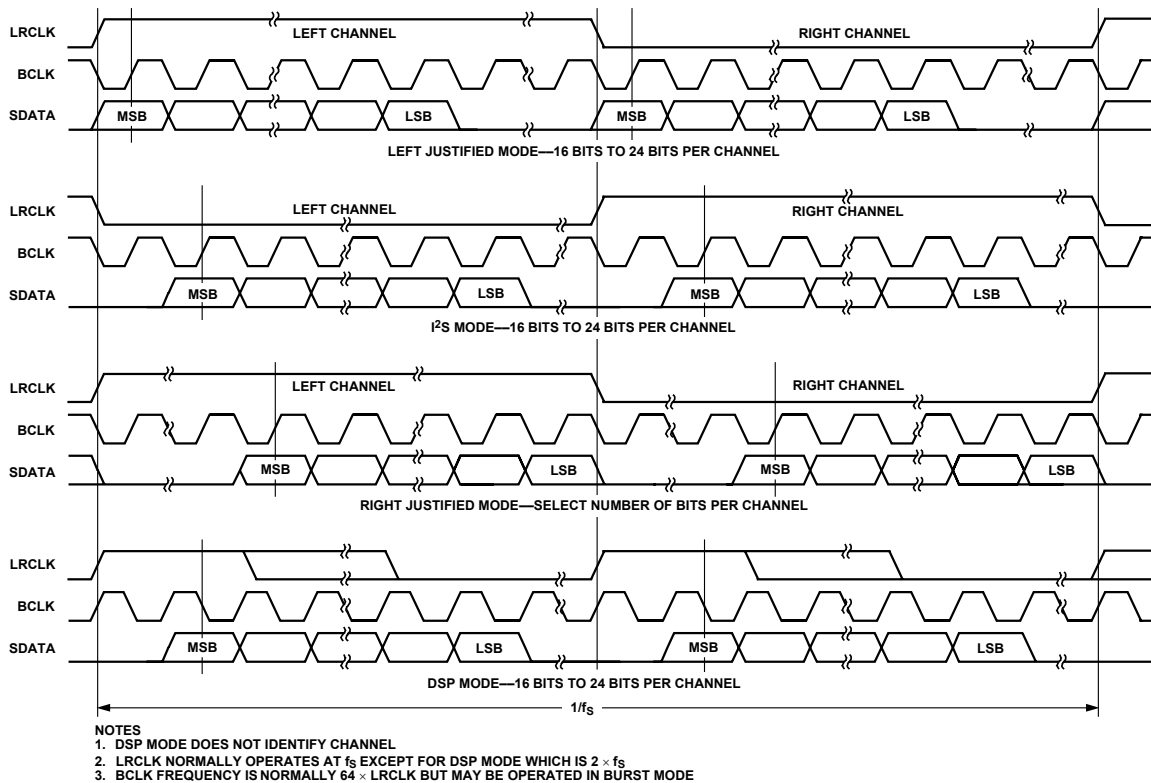

Figure 13. Stereo Serial Modes

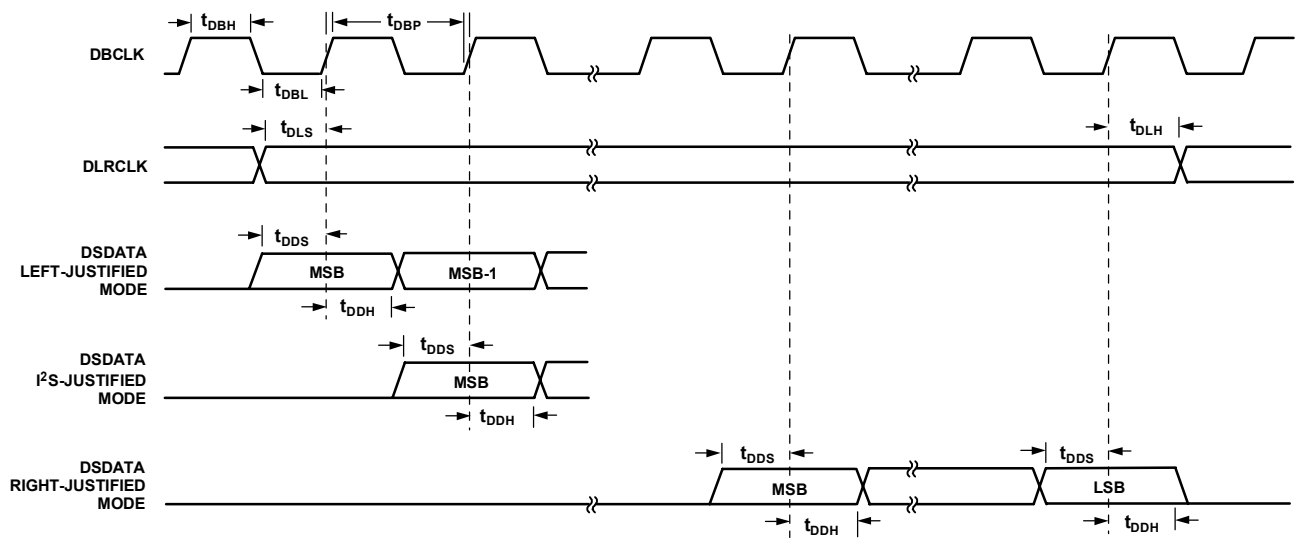

Figure 14. DAC Serial Timing

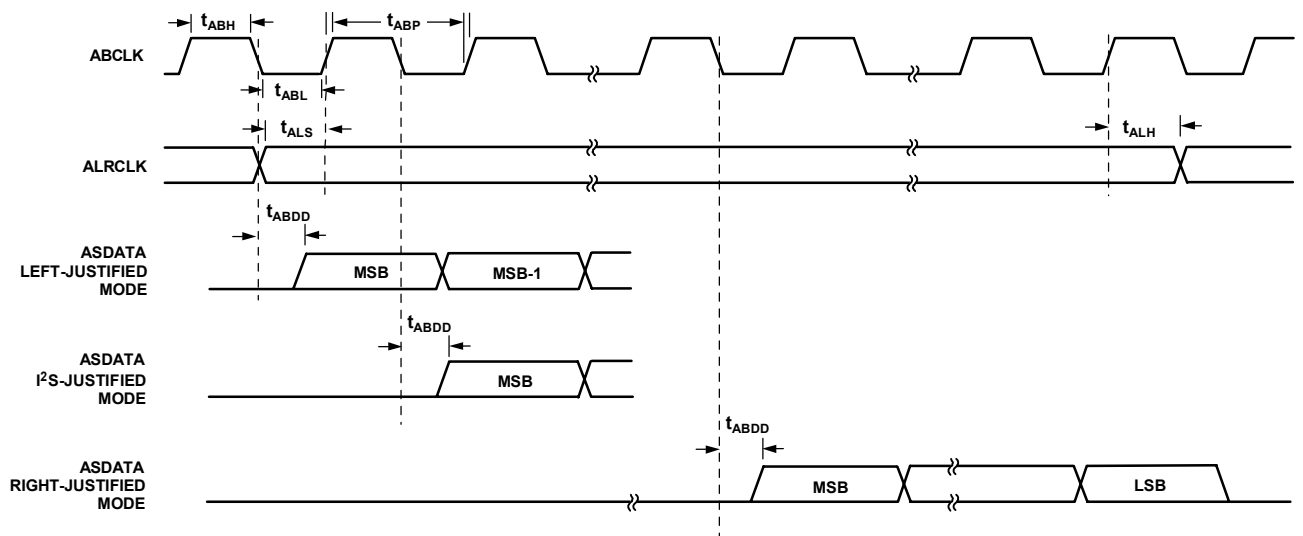

Figure 15. ADC Serial Timing

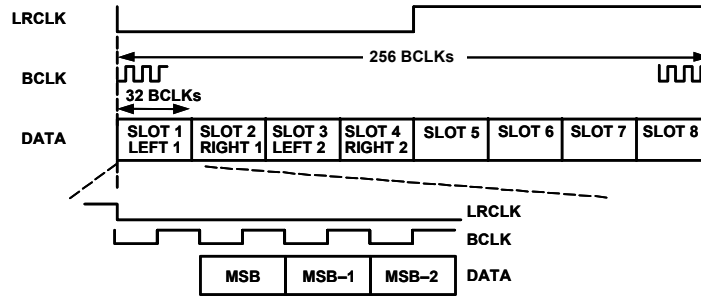

Figure 16. ADC TDM (8-channel I<sup>2</sup>S mode)

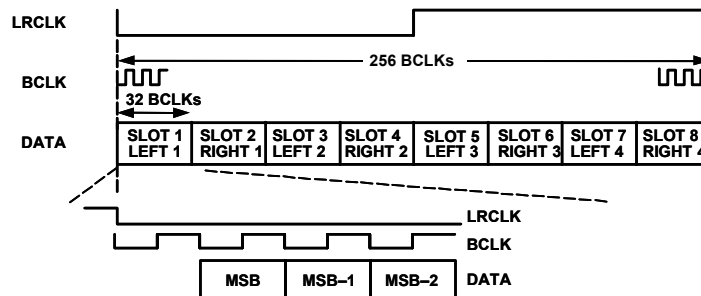
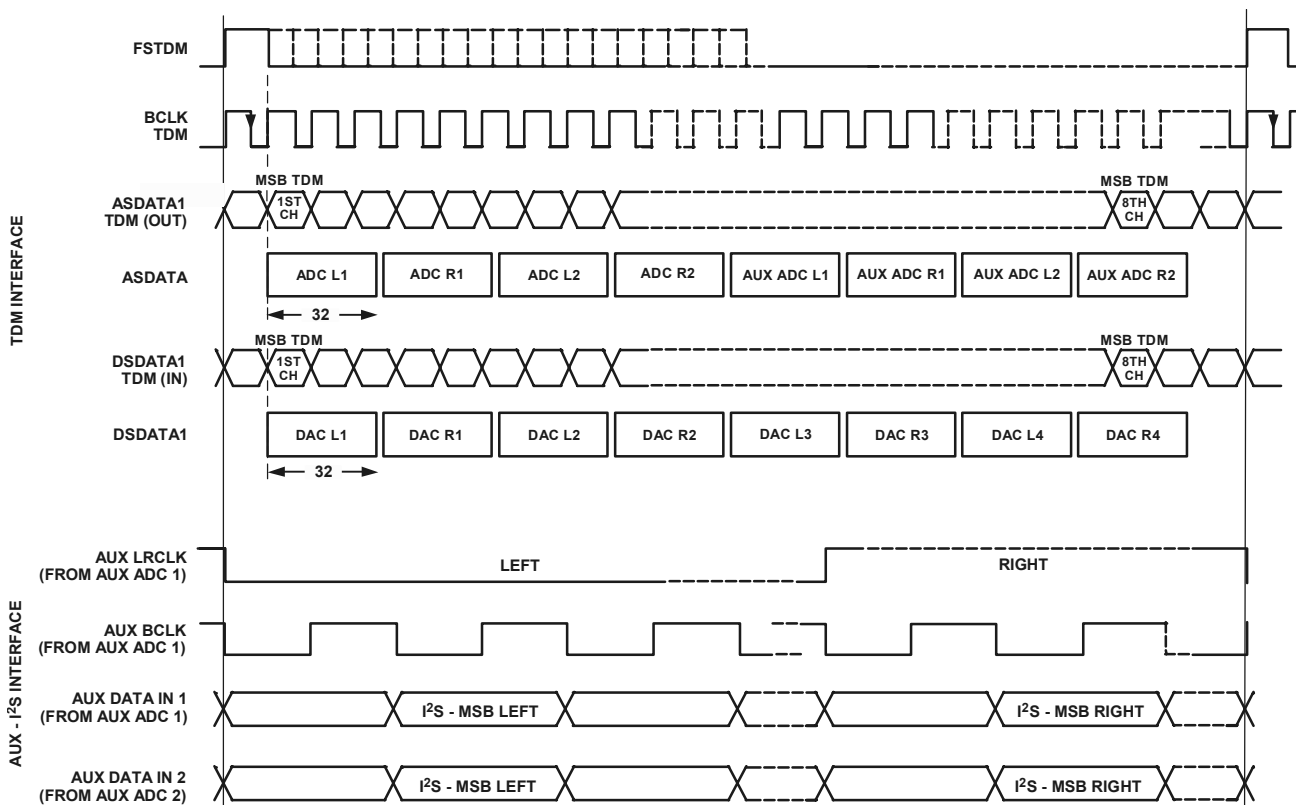

Figure 17. DAC TDM (8-channel I<sup>2</sup>S mode)



AUX BCLK FREQUENCY IS 64 × FRAME-RATE; TDM BCLK FREQUENCY IS 256 × FRAME-RATE.

Figure 18. AUX 256 Mode Timing (Note that the Clocks Are Not to Scale)

**Pin Function Changes in TDM and AUX Modes**

Pin Name	Stereo Modes	TDM Modes	AUX Modes
ASDATA1	ADC1 Data Out	ADC TDM Data Out	TDM Data Out
ASDATA2	ADC2 Data Out	ADC TDM Data In	AUX Data Out 1 (to Ext. DAC 1)
DSDATA1	DAC1 Data In	DAC TDM Data In	TDM Data In
DSDATA2	DAC2 Data In	DAC TDM Data Out	AUX Data In 1 (from Ext. ADC 1)
DSDATA3	DAC3 Data In	DAC TDM Data In 2 (dual-line mode)	AUX Data In 2 (from Ext. ADC 2)
DSDATA4	DAC4 Data In	DAC TDM Data Out 2 (dual-line mode)	AUX Data Out 2 (to Ext. DAC 2)
ALRCLK	ADC LRCLK In/Out	ADC TDM Frame Sync In/Out	TDM Frame Sync In/Out
ABCLK	ADC BCLK In/Out	ADC TDM BCLK In/Out	TDM BCLK In/Out
DLRCLK	DAC LRCLK In/Out	DAC TDM Frame Sync In/Out	AUX LRCLK In/Out
DBCLK	DAC BCLK In/Out	DAC TDM BCLK In/Out	AUX BCLK In/Out

Table 12

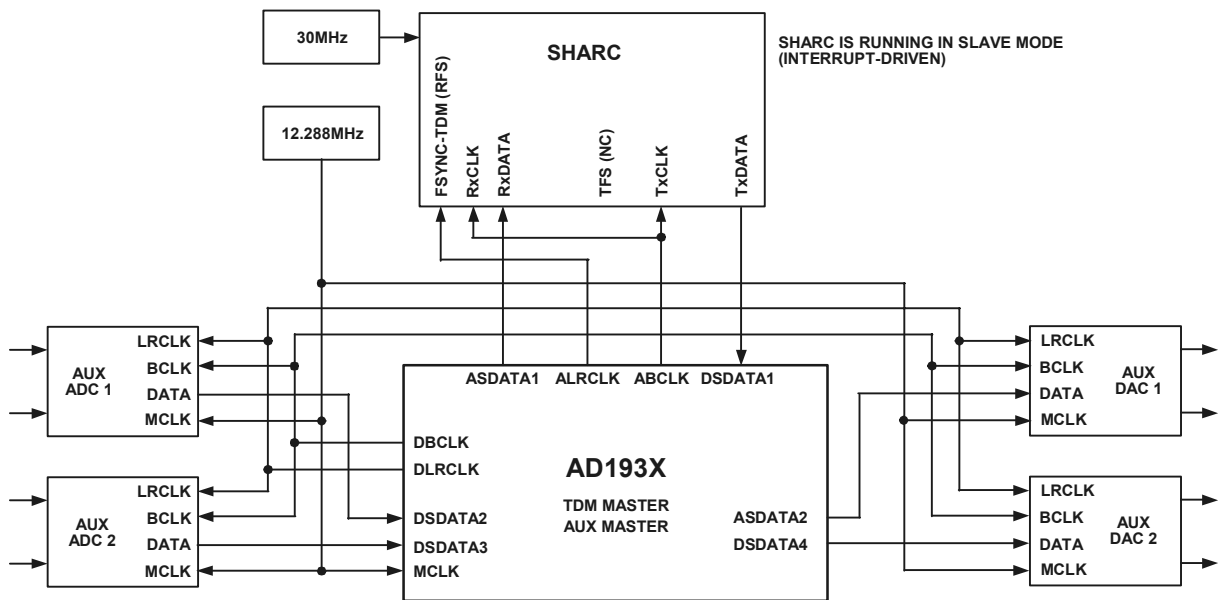

Figure 19. Example of AUX Mode Connection to SHARC (AD193X as TDM Master/AUX Master shown)

## PIN FUNCTION DESCRIPTIONS

## 48-Lead LQFP Plastic Package – AD1936, AD1938

Pin No.	In/Out	Mnemonic	Description
1	I	AGND	Analog Ground.
2	I	MCLKI/XI	Master Clock Input/ Crystal Oscillator Input.
3	I	MCLK/XO	Master Clock Output/ Crystal Oscillator Output.
4	I	AGND	Analog Ground.
5	I	AVDD	Analog Power Supply. Connect to analog 3.3 V supply.
6	O	OL3	DAC 3 Left Output.
7	O	OR3	DAC 3 Right Output.
8	O	OL4	DAC 4 Left Output.
9	O	OR4	DAC 4 Right Output.
10	I	$\overline{\text{PD/RST}}$	Power-Down Reset (Active Low).
11	I	DSDATA4	DAC Input 4 (Input to DAC 4 L and R).
12	I	DGND	Digital Ground.
13	I	DVDD	Digital Power Supply. Connect to digital 3.3 V supply.
14	I	DSDATA3	DAC Input 3 (Input to DAC 3 L and R).
15	I	DSDATA2	DAC Input 2 (Input to DAC 2 L and R).
16	I	DSDATA1	DAC Input 1 (Input to DAC 1 L and R).
17	I/O	DBCLK	Bit Clock for DACs.
18	I/O	DLRCLK	LR Clock for DACs.
19	O	ASDATA2	ADC Serial Data Output 2 (ADC 2 L and R).
20	O	ASDATA1	ADC Serial Data Output 1 (ADC 1 L and R).
21	I/O	ABCLK	Bit Clock for ADCs.
22	I/O	ALRCLK	LR Clock for ADCs.
23	O	CIN/ADR0	Control Data Input (SPI)/Address 0 (I <sup>2</sup> C).
24	I	COUT/SDA	Control Data Output (SPI)/Serial Data (I <sup>2</sup> C).
25	I	DGND	Digital Ground.
26	I	CCLK/SCL	Control Clock Input (SPI)/Serial Clock (I <sup>2</sup> C).
27	I	$\overline{\text{CLATCH}}/\text{ADR1}$	Latch Input for Control Data (SPI)/Address 1 (I <sup>2</sup> C).
28	O	OL1	DAC 1 Left Output.
29	O	OR1	DAC 1 Right Output.
30	O	OL2	DAC 2 Left Output.
31	O	OR2	DAC 2 Right Output.
32	I	AGND	Analog Ground.
33	I	AVDD	Analog Power Supply. Connect to analog 3.3 V supply.
34	I	AGND	Analog Ground.
35	O	FILTR	Voltage Reference Filter Capacitor Connection. Bypass with 10 $\mu\text{F}$   100 nF to AGND.
36	I	AGND	Analog Ground.
37	I	AVDD	Analog Power Supply. Connect to analog 3.3 V supply.
38	O	CM	Common Mode Reference Filter Capacitor Connection. Bypass with 10 $\mu\text{F}$   100 nF to AGND.
39	I	ADC1LP	ADC1 Left Positive Input.
40	I	ADC1LN	ADC1 Left Negative Input.
41	I	ADC1RP	ADC1 Right Positive Input.
42	I	ADC1RN	ADC1 Right Negative Input.
43	I	ADC2LP	ADC2 Left Positive Input.
44	I	ADC2LN	ADC2 Left Negative Input.
45	I	ADC2RP	ADC2 Right Positive Input.
46	I	ADC2RN	ADC2 Right Negative Input.
47	O	LF	PLL Loop Filter, Return to AVDD.
48	I	AVDD	Analog Power Supply. Connect to analog 3.3 V supply.

Table 13. Pin Function Description—48-Lead LQFP (AD1936, AD1938)



## 64-Lead LQFP Plastic Package – AD1937, AD1939

Pin No.	In/Out	Mnemonic	Description
1	I	AGND	Analog Ground.
2	I	MCLKI/XI	Master Clock Input/ Crystal Oscillator Input.
3	I	MCLK/XO	Master Clock Output/ Crystal Oscillator Output.
4	I	AGND	Analog Ground.
5	I	AVDD	Analog Power Supply. Connect to analog 3.3 V supply.
6	O	OL3P	DAC 3 Left Positive Output.
7	O	OL3N	DAC 3 Left Negative Output.
8	O	OR3P	DAC 3 Right Positive Output.
9	O	OR3N	DAC 3 Right Negative Output.
10	O	OL4P	DAC 4 Left Positive Output.
11	O	OL4N	DAC 4 Left Negative Output.
12	O	OR4P	DAC 4 Right Positive Output.
13	O	OR4N	DAC 4 Right Negative Output.
14	I	$\overline{\text{PD/RST}}$	Power-Down Reset (Active Low).
15	I	DSDATA4	DAC Input 4 (Input to DAC 4 L and R).
16	I	DGND	Digital Ground.
17	I	DVDD	Digital Power Supply. Connect to digital 3.3 V supply.
18	I	DSDATA3	DAC Input 3 (Input to DAC 3 L and R).
19	I	DSDATA2	DAC Input 2 (Input to DAC 2 L and R).
20	I	DSDATA1	DAC Input 1 (Input to DAC 1 L and R).
21	I/O	DBCLK	Bit Clock for DACs.
22	I/O	DLRCLK	LR Clock for DACs.
23		VSUPPLY	+5V Input to Regulator, Emitter of Pass Transistor
24		VSENSE	+3.3V Output of Regulator, Collector of Pass Transistor
25		VDRIVE	Drive for Base of Pass Transistor
26	O	ASDATA2	ADC Serial Data Output 2 (ADC 2 L and R).
27	O	ASDATA1	ADC Serial Data Output 1 (ADC 1 L and R).
28	I/O	ABCLK	Bit Clock for ADCs.
29	I/O	ALRCLK	LR Clock for ADCs.
30	I	CIN/ADR0	Control Data Input (SPI)/Address 0 (I <sup>2</sup> C).
31	I/O	COUT/SDA	Control Data Output (SPI)/Serial Data (I <sup>2</sup> C).
32	I	DVDD	Digital Power Supply. Connect to digital 3.3 V supply.
33	I	DGND	Digital Ground.
34	I	CCLK/SCL	Control Clock Input (SPI)/Serial Clock (I <sup>2</sup> C).
35	I	$\overline{\text{CLATCH/ADR1}}$	Latch Input for Control Data (SPI)/Address 1 (I <sup>2</sup> C).
36	O	OL1P	DAC 1 Left Positive Output.
37	O	OL1N	DAC 1 Left Negative Output.
38	O	OR1P	DAC 1 Right Positive Output.
39	O	OR1N	DAC 1 Right Negative Output.
40	O	OL2P	DAC 2 Left Positive Output.
41	O	OL2N	DAC 2 Left Negative Output.
42	O	OR2P	DAC 2 Right Positive Output.
43	O	OR2N	DAC 2 Right Negative Output.
44	I	AGND	Analog Ground.
45	I	AVDD	Analog Power Supply. Connect to analog 3.3 V supply.
46	I	AGND	Analog Ground.
47	O	FILTR	Voltage Reference Filter Capacitor Connection. Bypass with 10 $\mu\text{F}$   100 nF to AGND.
48	I	AGND	Analog Ground.
49			No Connect.
50			No Connect.
51	I	AVDD	Analog Power Supply. Connect to analog 3.3 V supply.

Pin No.	In/Out	Mnemonic	Description
52	O	CM	Common Mode Reference Filter Capacitor Connection. Bypass with 10 $\mu$ F  100 nF to AGND.
53	I	ADC1LP	ADC1 Left Positive Input.
54	I	ADC1LN	ADC1 Left Negative Input.
55	I	ADC1RP	ADC1 Right Positive Input.
56	I	ADC1RN	ADC1 Right Negative Input.
57	I	ADC2LP	ADC2 Left Positive Input.
58	I	ADC2LN	ADC2 Left Negative Input.
59	I	ADC2RP	ADC2 Right Positive Input.
60	I	ADC2RN	ADC2 Right Negative Input.
61	O	LF	PLL Loop Filter, Return to AVDD.
62	I	AVDD	Analog Power Supply. Connect to analog 3.3 V supply.
63			No Connect.
64			No Connect.

Table 14. Pin Function Description—64-Lead LQFP (AD1937, AD1939)

**64-Lead LQFP Plastic Package – AD1935**

Pin No.	In/Out	Mnemonic	Description
1	I	AGND	Analog Ground.
2	I	MCLKI/XI	Master Clock Input/ Crystal Oscillator Input.
3	I	MCLK/XO	Master Clock Output/ Crystal Oscillator Output.
4	I	AGND	Analog Ground.
5	I	AVDD	Analog Power Supply. Connect to analog 3.3 V supply.
6	O	OL3	DAC 3 Left Output.
7	O		No Connect.
8	O	OR3	DAC 3 Right Output.
9	O		No Connect.
10	O	OL4	DAC 4 Left Output.
11	O		No Connect.
12	O	OR4	DAC 4 Right Output.
13	O		No Connect.
14	I	$\overline{\text{PD/RST}}$	Power-Down Reset (Active Low).
15	I	DSDATA4	DAC Input 4 (Input to DAC 4 L and R).
16	I	DGND	Digital Ground.
17	I	DVDD	Digital Power Supply. Connect to digital 3.3 V supply.
18	I	DSDATA3	DAC Input 3 (Input to DAC 3 L and R).
19	I	DSDATA2	DAC Input 2 (Input to DAC 2 L and R).
20	I	DSDATA1	DAC Input 1 (Input to DAC 1 L and R).
21	I/O	DBCLK	Bit Clock for DACs.
22	I/O	DLRCLK	LR Clock for DACs.
23		VSUPPLY	+5V Input to Regulator, Emitter of Pass Transistor
24		VSENSE	+3.3V Output of Regulator, Collector of Pass Transistor
25		VDRIVE	Drive for Base of Pass Transistor
26	O	ASDATA2	ADC Serial Data Output 2 (ADC 2 L and R).
27	O	ASDATA1	ADC Serial Data Output 1 (ADC 1 L and R).
28	I/O	ABCLK	Bit Clock for ADCs.
29	I/O	ALRCLK	LR Clock for ADCs.
30	I	CIN	Control Data Input (SPI)
31	I/O	COUT	Control Data Output (SPI)
32	I	DVDD	Digital Power Supply. Connect to digital 3.3 V supply.
33	I	DGND	Digital Ground.
34	I	CCLK	Control Clock Input (SPI)
35	I	$\overline{\text{CLATCH}}$	Latch Input for Control Data (SPI)

Pin No.	In/Out	Mnemonic	Description
36	O	OL1	DAC 1 Left Output.
37	O		No Connect.
38	O	OR1	DAC 1 Right Output.
39	O		No Connect.
40	O	OL2	DAC 2 Left Output.
41	O		No Connect.
42	O	OR2	DAC 2 Right Output.
43	O		No Connect.
44	I	AGND	Analog Ground.
45	I	AVDD	Analog Power Supply. Connect to analog 3.3 V supply.
46	I	AGND	Analog Ground.
47	O	FILTR	Voltage Reference Filter Capacitor Connection. Bypass with 10 $\mu$ F  100 nF to AGND.
48	I	AGND	Analog Ground.
49			No Connect.
50			No Connect.
51	I	AVDD	Analog Power Supply. Connect to analog 3.3 V supply.
52	O	CM	Common Mode Reference Filter Capacitor Connection. Bypass with 10 $\mu$ F  100 nF to AGND.
53	I	ADC1LP	ADC1 Left Positive Input.
54	I	ADC1LN	ADC1 Left Negative Input.
55	I	ADC1RP	ADC1 Right Positive Input.
56	I	ADC1RN	ADC1 Right Negative Input.
57	I	ADC2LP	ADC2 Left Positive Input.
58	I	ADC2LN	ADC2 Left Negative Input.
59	I	ADC2RP	ADC2 Right Positive Input.
60	I	ADC2RN	ADC2 Right Negative Input.
61	O	LF	PLL Loop Filter, Return to AVDD.
62	I	AVDD	Analog Power Supply. Connect to analog 3.3 V supply.
63			No Connect.
64			No Connect.

Table 15. Pin Function Description—64-Lead LQFP (AD1935)

## PIN CONFIGURATION

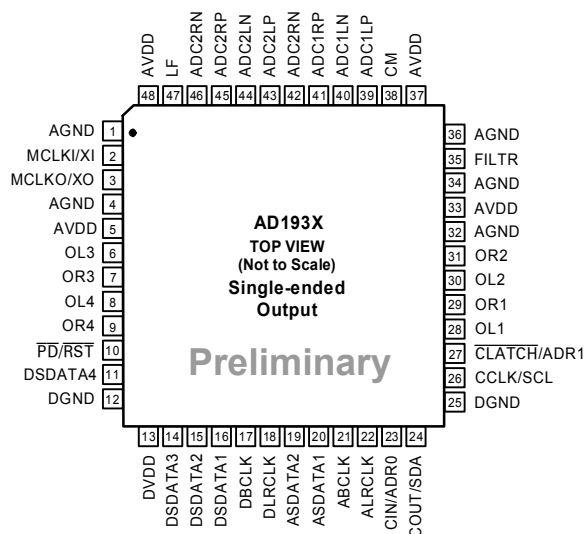

Figure 20. Single-ended Output 48-Lead LQFP (AD1936, AD1938)

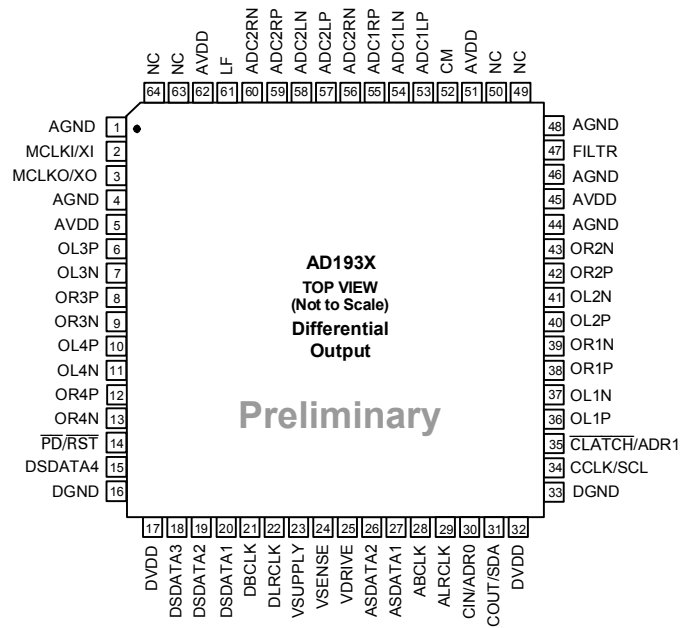

Figure 21. Differential Output 64-Lead LQFP (AD1937, AD1939)

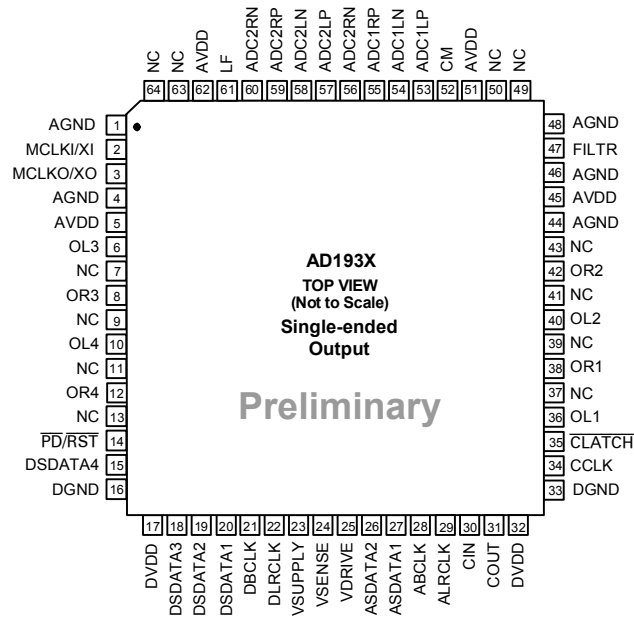

Figure 22. Single-ended Output Output 64-Lead LQFP (AD1935)

## APPLICATION CIRCUITS

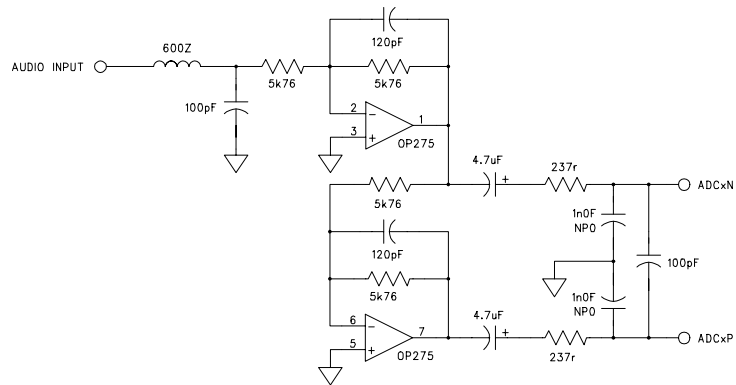

Figure 23. Typical ADC Input Filter Circuit

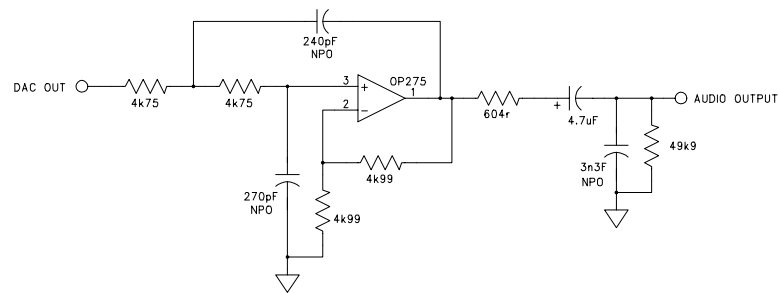

Figure 24. Typical DAC Output Filter Circuit (Single-ended, Non-inverting)

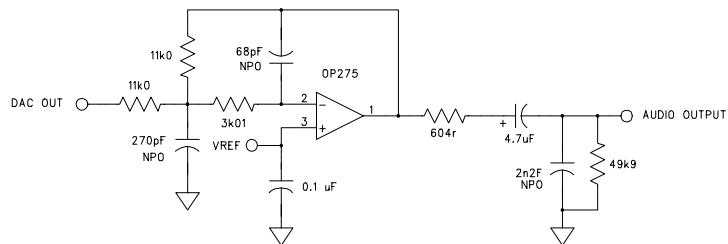

Figure 25. Typical DAC Output Filter Circuit (Single-ended, Inverting)

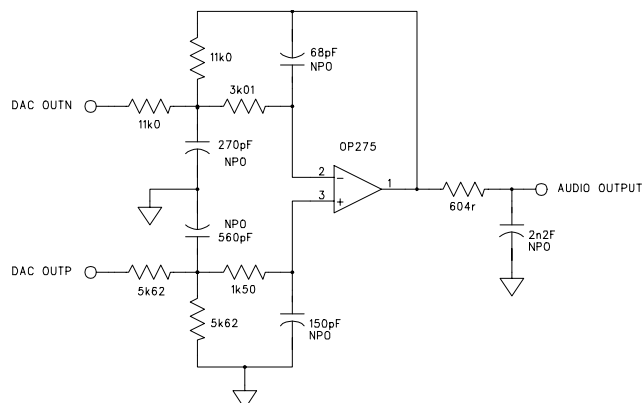

Figure 26. Typical DAC Output Filter Circuit (Differential)

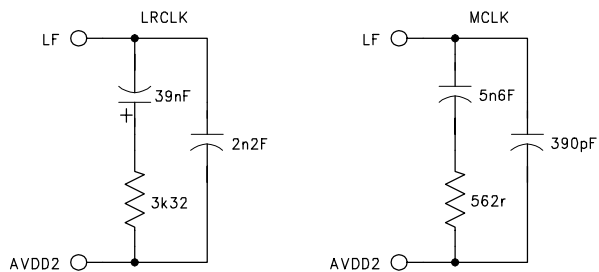

Figure 27. Recommended Loop Filters for LRCLK or MCLK PLL reference.

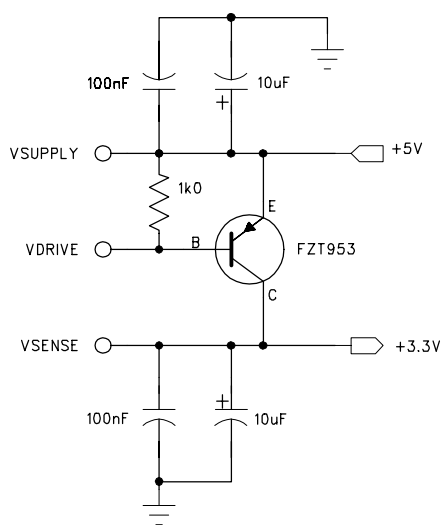

Figure 28. Recommended 3.3V Regulator Circuit (64-lead versions)

## REGISTER DEFINITIONS

### Register format

	Global Address	R/W	Register Address	Data
Bit	23:17	16	15:8	7:0

Table 16

Note 1: The format is the same for I<sup>2</sup>C and SPI.

Note 2: Global address for the AD193X series is 0x04, shifted left 1 bit due to the R/W bit.

Note 3: In I<sup>2</sup>C, ADR0 and ADR1 are ORed into bits 17 and 18 to provide multiple chip addressing.

Note 4: All registers are reset to 0, except for the DAC volume registers which are set to full volume.

### Register addresses and functions

Address	Function
0	PLL and Clock Control 0
1	PLL and Clock Control 1
2	DAC Control 0
3	DAC Control 1
4	DAC Control 2
5	DAC Individual Channel Mutes
6	DAC 1L Vol Control
7	DAC 1R Vol Control
8	DAC 2L Vol Control
9	DAC 2R Vol Control
10	DAC 3L Vol Control
11	DAC 3R Vol Control
12	DAC 4L Vol Control
13	DAC 4R Vol Control
14	ADC Control 0
15	ADC Control 1
16	ADC Control 2

Table 17

## PLL AND CLOCK CONTROL REGISTERS

### PLL and Clock control 0

Bit	Value	Function	Description
0	0	Normal operation	PLL power down
	1	Power down	
2:1	00	INPUT 256 (x 44.1 or 48kHz)	MCLK pin functionality (PLL active)
	01	INPUT 384 (x 44.1 or 48kHz)	
	10	INPUT 512 (x 44.1 or 48kHz)	
	11	INPUT 768 (x 44.1 or 48kHz)	
4:3	00	XTAL Oscillator Enabled	MCLK_O pin
	01	256xfs VCO Output	
	10	512xfs VCO Output	
	11	Off	
6:5	00	MCLK	PLL input
	01	DLRCLK	
	10	ALRCLK	
	11	Reserved	
7	0	Disable: ADC and DAC Idle	Internal MCLK Enable
	1	Enable: ADC and DAC Active	

Table 18

### PLL and Clock control 1

Bit	Value	Function	Description
0	0	PLL Clock	DAC Clock Source Select
	1	MCLK	
1	0	PLL Clock	ADC Clock Source Select
	1	MCLK	
2	0	Enabled	On-chip Voltage Reference
	1	Disabled	
3	0	Not Locked	PLL Lock Indicator (Read Only)
	1	Locked	
7:4	0000	Reserved	

Table 19



**DAC CONTROL REGISTERS****DAC control 0**

Bit	Value	Function	Description
0	0	Normal	Power Down
	1	Power down	
2:1	00	32/44.1/48 kHz	Sample Rate
	01	64/88.2/96 kHz	
	10	128/176.4/192 kHz	
	11	Reserved	
5:3	000	1	SDATA Delay (BCLK periods)
	001	0	
	010	8	
	011	12	
	100	16	
	101	Reserved	
	110	Reserved	
	111	Reserved	
7:6	00	Stereo (Normal)	Serial Format
	01	TDM (Daisy Chain)	
	10	DAC Aux mode (ADC, DAC TDM coupled)	
	11	Dual-line TDM	

Table 20

**DAC control 1**

Bit	Value	Function	Description
0	0	Latch in mid cycle (normal)	BCLK Active Edge (TDM In)
	1	Latch in at end of cycle (pipeline)	
2:1	00	64 (2 channels)	BCLKs Per Frame
	01	128 (4 channels)	
	10	256 (8 channels)	
	11	512 (16 channels)	
3	0	Left low	LRCLK Polarity
	1	Left high	
4	0	Slave	LRCLK Master/Slave
	1	Master	
5	0	Slave	BCLK Master/Slave
	1	Master	
6	0	DBCLK pin	BCLK Source
	1	Internally generated	
7	0	Normal	BCLK Polarity
	1	Inverted	

Table 21

**DAC control 2**

Bit	Value	Function	Description
0	0	Unmute	Master Mute
	1	Mute	
2:1	00	Flat	Deemphasis (32/44.1/48 kHz mode only)
	01	48 kHz Curve	
	10	44.1 kHz Curve	
	11	32 kHz Curve	
4:3	00	24	Word width
	01	20	
	10	Reserved	
	11	16	
5	0	Non-inverted	DAC Output Polarity
	1	Inverted	
7:6	00	Reserved	

Table 22

**DAC Individual Channel Mutes**

Bit	Value	Function	Description
0	0	Unmute	DAC 1 Left Mute
	1	Mute	
1	0	Unmute	DAC 1 Right Mute
	1	Mute	
2	0	Unmute	DAC 2 Left Mute
	1	Mute	
3	0	Unmute	DAC 2 Right Mute
	1	Mute	
4	0	Unmute	DAC 3 Left Mute
	1	Mute	
5	0	Unmute	DAC 3 Right Mute
	1	Mute	
6	0	Unmute	DAC 4 Left Mute
	1	Mute	
7	0	Unmute	DAC 4 Right Mute
	1	Mute	

Table 23

**DAC Volume Controls**

Bit	Value	Function	Description
7:0	0	No attenuation	DAC Volume Control
	1-254	-3/8 dB per step	
	255	Full Attenuation	

Table 24

### ADC CONTROL REGISTERS

#### ADC control 0

Bit	Value	Function	Description
0	0	Normal	Power Down
	1	Power down	
1	0	Off	Highpass Filter
	1	On	
2	0	Unmute	ADC 1L mute
	1	Mute	
3	0	Unmute	ADC 1R mute
	1	Mute	
4	0	Unmute	ADC 2L mute
	1	Mute	
5	0	Unmute	ADC 2R mute
	1	Mute	
7:6	00	32/44.1/48	Output Sample Rate
	01	64/88.2/96	
	10	128/176.4/192	
	11	Reserved	

Table 25

#### ADC control 1

Bit	Value	Function	Description
1:0	00	24	Word width
	01	20	
	10	Reserved	
	11	16	
4:2	000	1	SDATA delay (BCLK periods)
	001	0	
	010	8	
	011	12	
	100	16	
	101	Reserved	
	110	Reserved	
	111	Reserved	
6:5	00	Stereo	Serial Format
	01	TDM (Daisy Chain)	
	10	ADC Aux mode (ADC, DAC TDM coupled)	
	11	Reserved	
7	0	Latch in mid cycle (normal)	BCLK Active Edge (TDM In)
	1	Latch in at end of cycle (pipeline)	

Table 26.

## ADC control 2

Bit	Value	Function	Description
0	0	50/50 (allows 32/24/20/16 BCLK/channel)	LRCLK Format
	1	Pulse (32 BCLK/channel)	
1	0	Drive out on falling edge (DEF)	BCLK Polarity
	1	Drive out on rising edge	
2	0	Left Low	LRCLK Polarity
	1	Left High	
3	0	Slave	LRCLK Master/Slave
	1	Master	
5:4	00	64	BCLKs per frame
	01	128	
	10	256	
	11	512	
6	0	Slave	BCLK Master/Slave
	1	Master	
7	0	ABCLK pin	BCLK Source
	1	Internally generated	

Table 27

## OUTLINE DIMENSIONS

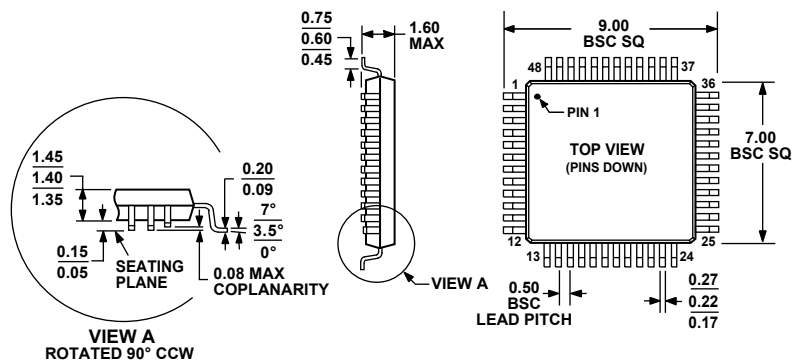

COMPLIANT TO JEDEC STANDARDS MS-026-BBC

Figure 29. 48-Lead Low Profile Quad Flat Package [LQFP] (ST-48)

Dimensions shown in millimeters

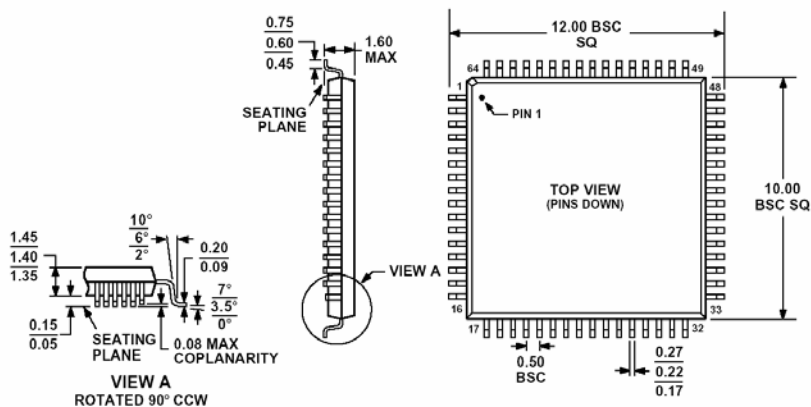

COMPLIANT TO JEDEC STANDARDS MS-026BCD

Figure 30. 64-Lead Low Profile Quad Flat Package [LQFP] (ST-64)

Dimensions shown in millimeters

### ESD CAUTION

ESD (electrostatic discharge) sensitive device. Electrostatic charges as high as 4000 V readily accumulate on the human body and test equipment and can discharge without detection. Although this product features proprietary ESD protection circuitry, permanent damage may occur on devices subjected to high energy electrostatic discharges. Therefore, proper ESD precautions are recommended to avoid performance degradation or loss of functionality.



## Ordering Guide

AD193X Products	Temperature Package (ambient)	Package Description	Package Option
AD1935XSTZ	-40°C to +105°C	64-Lead LQFP, SE out, SPI control w/ reg	ST-64
AD1935XSTZRL	-40°C to +105°C	64-Lead LQFP, SE out, SPI control w/ reg	ST-64 on 13" Reels
AD1936XSTZ	-40°C to +105°C	48-Lead LQFP, SE out, I <sup>2</sup> C control	ST-48
AD1936XSTZRL	-40°C to +105°C	48-Lead LQFP, SE out, I <sup>2</sup> C control	ST-48 on 13" Reels
AD1937XSTZ	-40°C to +105°C	64-Lead LQFP, Diff out, I <sup>2</sup> C control	ST-64
AD1937XSTZRL	-40°C to +105°C	64-Lead LQFP, Diff out, I <sup>2</sup> C control	ST-64 on 13" Reels
AD1938XSTZ	-40°C to +105°C	48-Lead LQFP, SE out, SPI control	ST-48
AD1938XSTZRL	-40°C to +105°C	48-Lead LQFP, SE out, SPI control	ST-48 on 13" Reels
AD1939XSTZ	-40°C to +105°C	64-Lead LQFP, Diff out, SPI control	ST-64
AD1939XSTZRL	-40°C to +105°C	64-Lead LQFP, Diff out, SPI control	ST-64 on 13" Reels
EVAL-AD1935EB		AD1935 Evaluation Board	
EVAL-AD1936EB		AD1936 Evaluation Board	
EVAL-AD1937EB		AD1937 Evaluation Board	
EVAL-AD1938EB		AD1938 Evaluation Board	
EVAL-AD1939EB		AD1939 Evaluation Board	

Note: All parts are lead-free

Table 28. Ordering Guide