

GT7 Series

<GT7, GT7A, and GT7W>

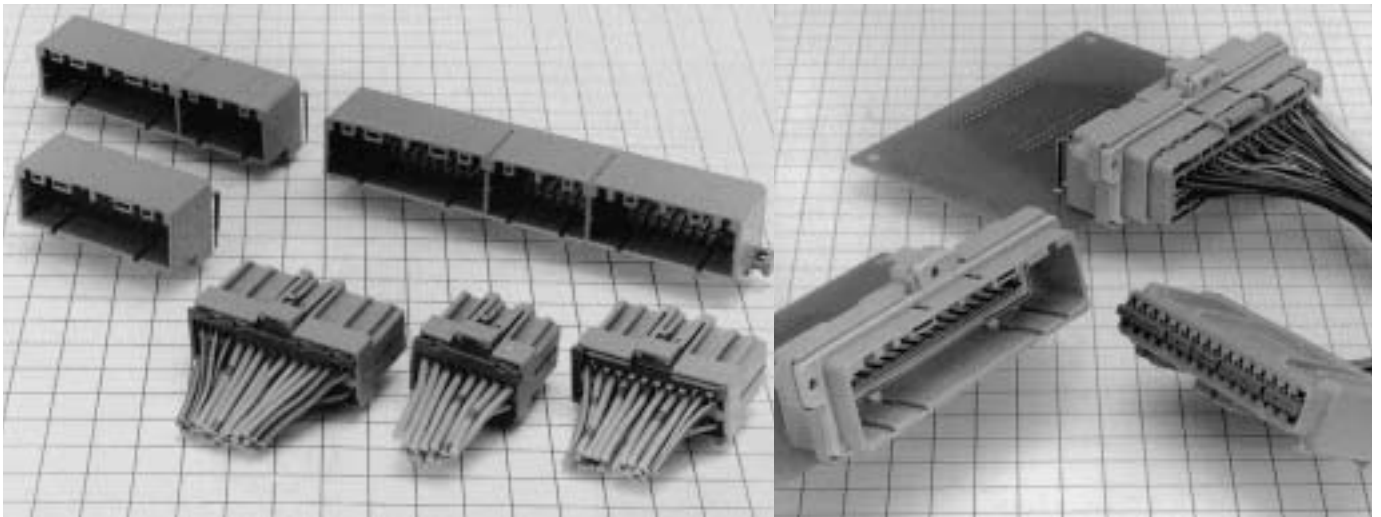

■ Features

- These automotive crimp terminals are equivalent to 040 and 070 tab width items.
- The contact portion of the F connector side has been given a double structure to make these connectors compatible with low insertion force and high contact pressure at the time of coupling.
- In this design, the contact portion is housed in a box that is formed by a press. This prevents the contact portion from being misshapen by an external force.
- The design of the waterproof connectors uses a 2-stage sequence having a low insertion force.

* A partial gold plating specification can be applied to only the terminals specified by the customer.

F Connectors

● Terminals

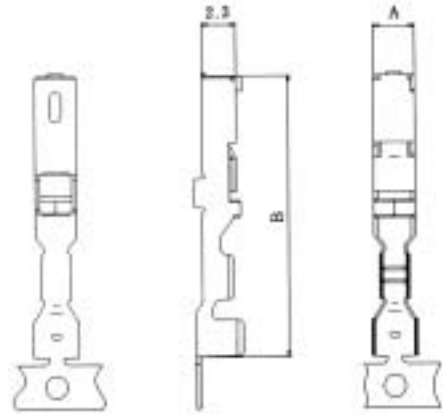

Part Number	CL No.	Material	Finish	Outer Diameter	A dimension	B dimension	Packaging
GT7-2022SCF	757-0001-1	Copper alloy	Tin plating	1.4 to 2.4	2.8	19	5,000 pcs. per reel
GT7A-2022SCF	757-0003-7			2.6 to 3.1			3,000 pcs. per reel
GT3-2024SCF	753-0006-0			1.4 to 2.4	2.3	15.7	5,000 pcs. per reel

Note 1: Sold by the reel.

Note 2: This component is used only with applicable HRS housings.

● Housing **16 Pos.**

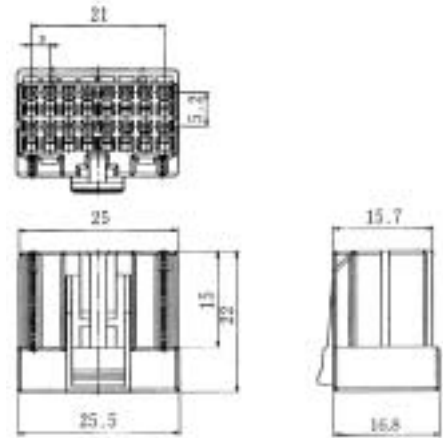

Part Number	CL No.	Material
GT7-16DS-HU	757-0008-0	PBT

● Retainer (Used with GT7-16DS-HU)

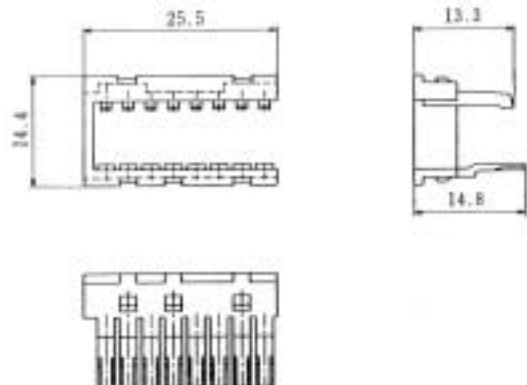

Part Number	CL No.	Material
GT7-16R	757-0010-2	PBT

● Housing **22 Pos.**



Part Number	CL No.	Material
GT7-22DS-HU	757-0015-6	PBT

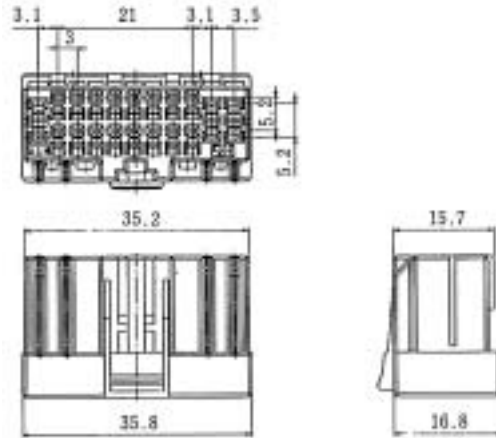

● Retainer (Used with GT7-22DS-HU)



Part Number	CL No.	Material
GT7-22R	757-0016-9	PBT

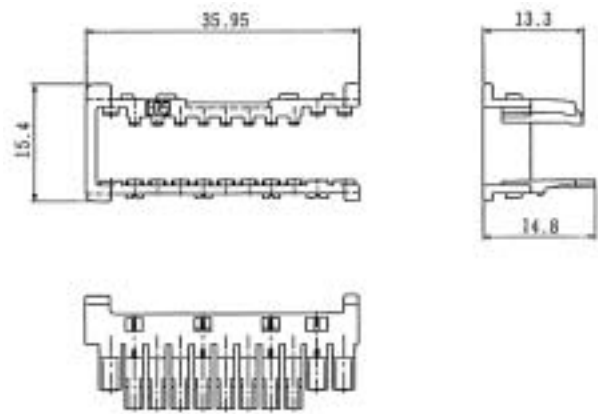

● Housing **26 Pos.**

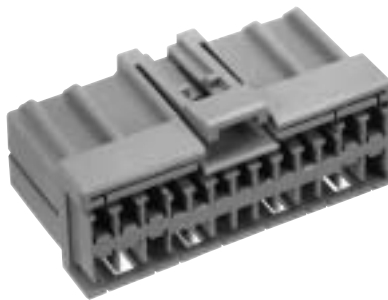

Part Number	CL No.	Material
GT7-26DS-HU	757-0009-3	PBT

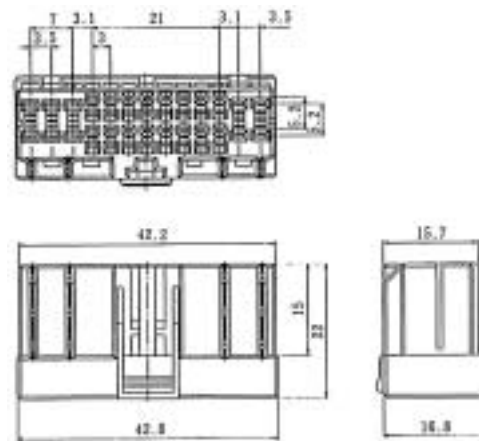

● Retainer (Used with GT7-26DS-HU)

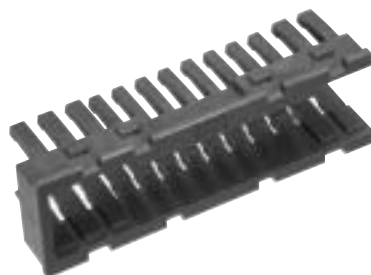

Part Number	CL No.	Material
GT7-26R	757-0011-5	PBT

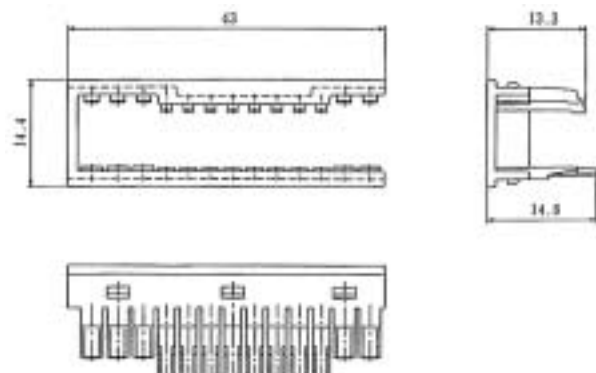

● Board Type / Hybrid Type

64 Pos.

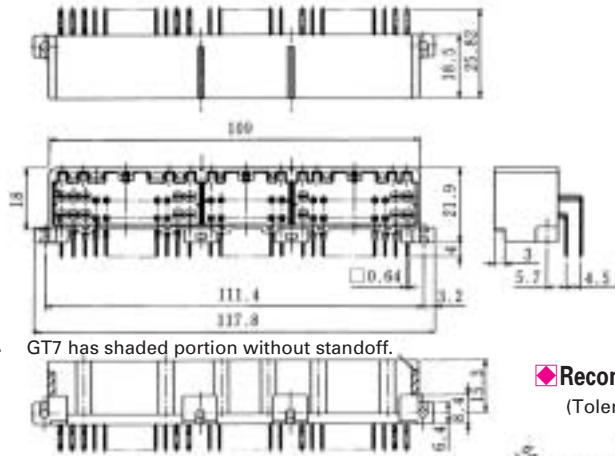

Mates with a 26-pos. + 16-pos. + 22-pos. F connector.

GT7 has shaded portion without standoff.

◆ Recommended Board Mounting Pattern
(Tolerance of unmarked values is ±0.05.)

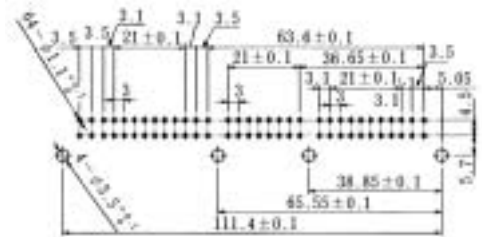

Part Number	CL No.	A
GT7A-64DP-DS	757-0012-8	3
GT7-64DP-DS	757-0005-2	Shaded portion without stand-off

◆ Termination Tools

User's manuals are available. Please ask your Hirose Electric account representative.

Automatic Crimping Machine



Part number CM-105

Item	Specification	Remarks
Specification	1.5ton	
Stroke Length	30mm	
Number of strokes	200spm(50 Hz)	240spm(60 Hz)
Weight	75 kg	
Motor	0.2kw	AC100V
Crimping speed	2,000 to 4,000 pcs. per hour	

Hand Tool



Crimp height setting tables are available for each cable type. Please contact your nearest Hirose Electric account representative. Different cables will require different crimp height settings.

Waterproof Type

F Connectors

● Terminals



Part Number	CL No.	Packaging
GT7W-1416SCF	757-0031-2	3,000 pcs. per reel

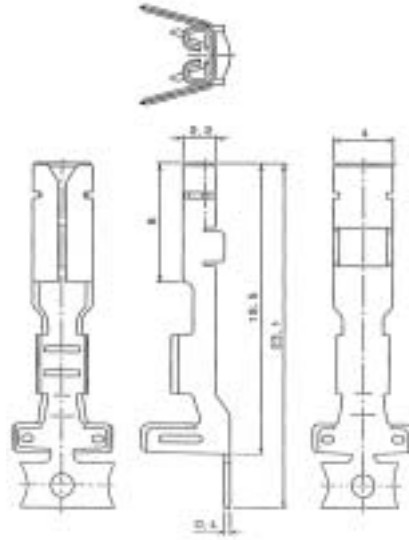

Part Number	CL No.	Packaging
GT7W-2022SCF	757-0017-1	5,000 pcs. per reel

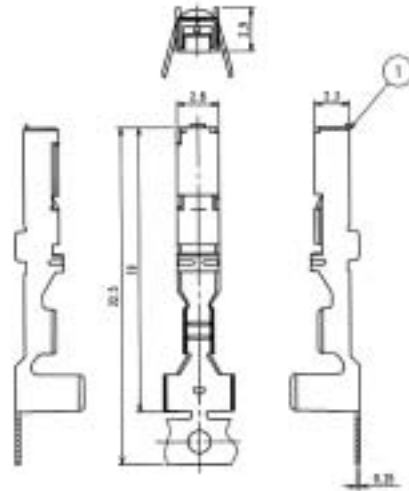

Part Number	CL No.	Packaging
GT3W-2024SCF	753-0016-3	5,000 pcs. per reel

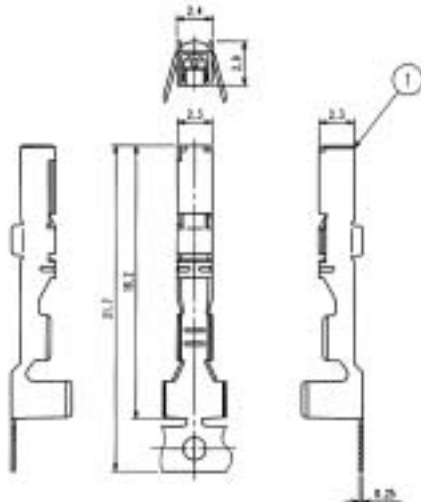

● Wire Seal

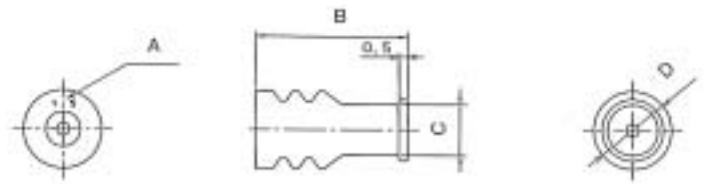

Part No.	CL No.	A	B	C	D	Color	Outer diameter of the cable
GT7W-1.5WS	757-0025-0	1.50	8.40	2.8	4.3	Blue	1.5 mm
GT7W-1.9WS	757-0026-2	1.90	8.40	3.2	4.7	Pink	1.9 mm
GT7W-3.4WS	757-0027-5	3.40	8.55	4.4	5.9	Pink	3.4 mm

● Dummy Seal

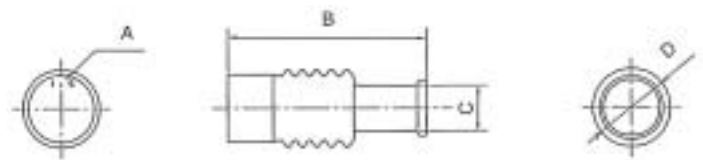

Part No.	CL No.	A	B	C	D	Color
GT7W-1.5DS	757-0028-8	1.50	10.90	2.5	4.3	Blue
GT7W-1.9DS	757-0029-0	1.90	10.40	2.9	4.7	Pink
GT7W-3.4DS	757-0030-0	3.40	10.70	5.9	5.9	Pink

● Housing **32 Pos.**

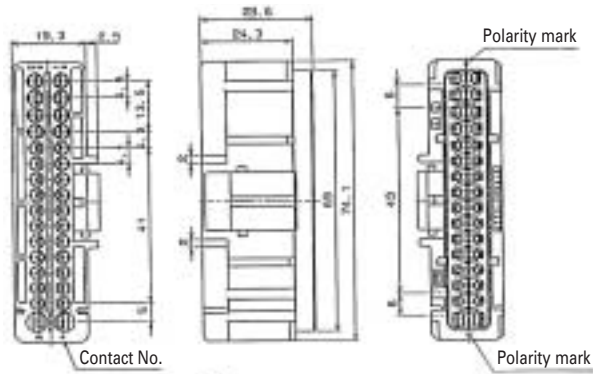

Part Number	CL No.	Color
GT7W-32DS-HUL	757-0021-9	Black

Note: Used with separate retainer (GT7-18R and GT7W-14R).

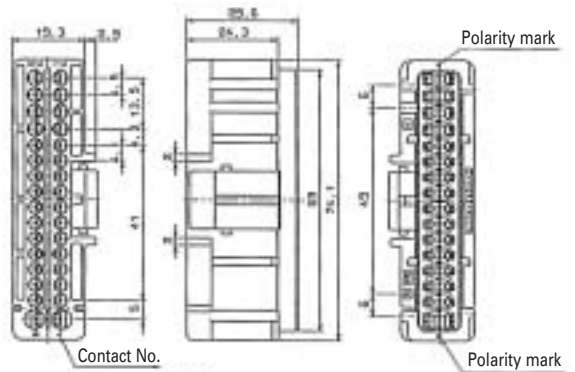

Note: Used with separate retainer (GT7-18R and GT7W-14R).

Part Number	CL No.	Color
GT7W-32DS-HUR	757-0022-1	Light gray



Retainer (exclusively for GT7W-32DS-HUL(R))

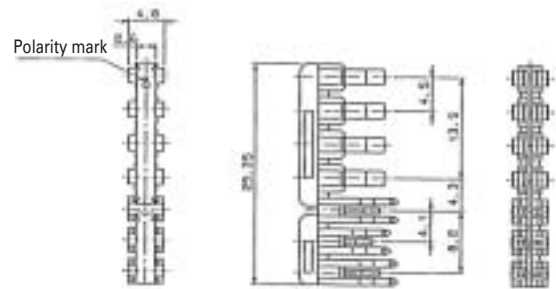

Part Number	CL No.
GT7W-14R	757-0023-4

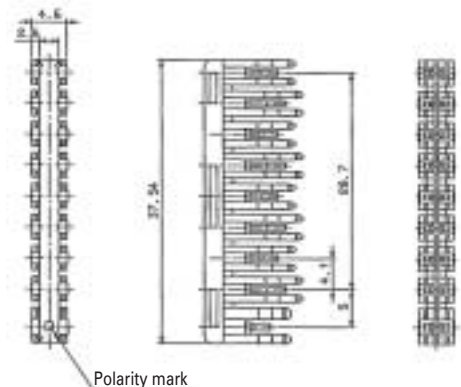

Part Number	CL No.
GT7W-18R	757-0024-7



M Connectors

● Board Type

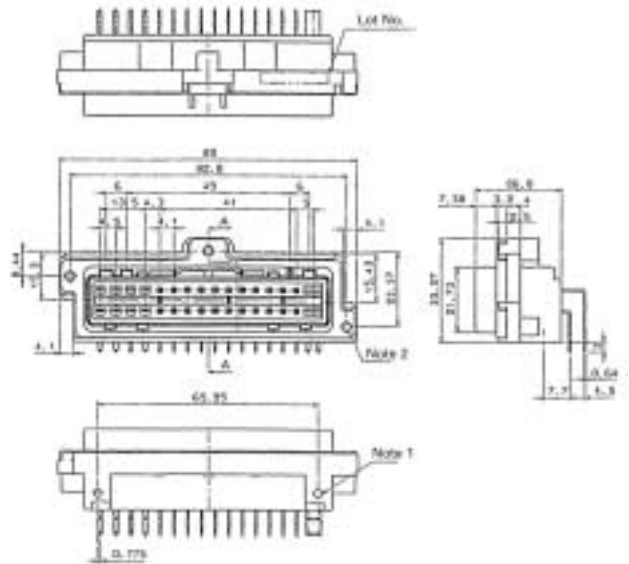
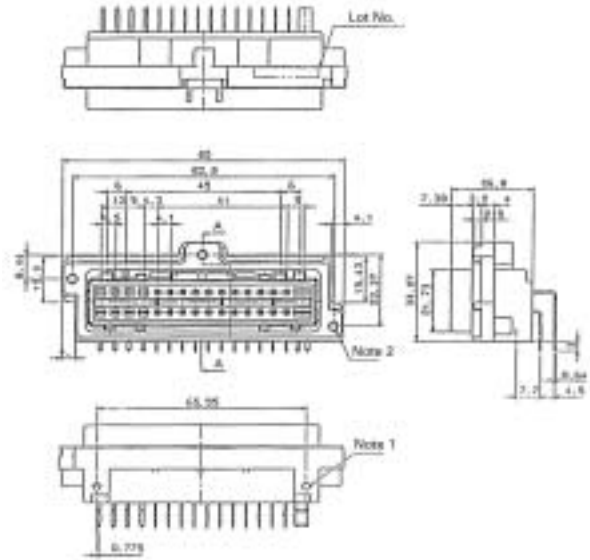

Part Number	CL No.	Key polarizing code	Color
GT7W-32DP-DSL	757-0019-7	A	Black
GT7W-32DP-DSR	757-0020-6	B	Light gray

Note 1: Use mounting screws of M3 with nominal diameter 3L-6.

Note 2: Use mounting screws of M3 with nominal diameter 3L-12.

Note 3: Tightening torque for the screws is 34.3 to 39.2 N.cm.

◆ Recommended Board Mounting Pattern

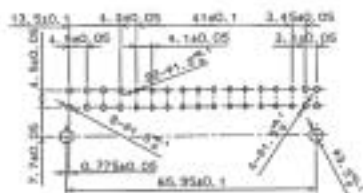

◆ Recommended Panel Cut-out

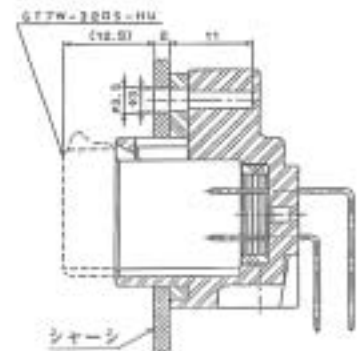
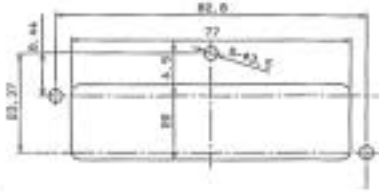

◆ Wiring Tools

Operation manuals are available for the various wiring tools. Please contact a Hirose Electric account representative.

Automatic Crimping Machine



Product number CM-105

Item	Specification	Remarks
Specification	1.5ton	
Stroke Length	30mm	
Number of strokes	200spm(50 Hz)	240spm(60 Hz)
Weight	75 kg	
Motor	0.2kw	AC100V
Crimping speed	2,000 to 4,000 pcs. per hour	