

**PLEASE CHECK WWW.MOLEX.COM FOR LATEST PART INFORMATION**

**Part Number:** [0557550419](#)  
**Status:** **Active**  
**Description:** 2.00mm (.079") Pitch Wire-to-Board Header, Vertical, Shrouded, Kinked PC Tail, with Inner Positive Lock, 4 Circuits, Lead-free

**Documents:**

[3D Model](#) [Product Specification PS-51216-007 \(PDF\)](#)  
[Drawing \(PDF\)](#) [RoHS Certificate of Compliance \(PDF\)](#)

**General**

Product Family	PCB Headers
Series	<a href="#">55755</a>
Application	Wire-to-Board
Product Name	N/A

**Physical**

Breakaway	No
Circuits (Loaded)	4
Circuits (maximum)	4
Color - Resin	Natural
Durability (mating cycles max)	30
First Mate / Last Break	No
Glow-Wire Compliant	No
Guide to Mating Part	No
Keying to Mating Part	None
Lock to Mating Part	Yes
Mated Height (in)	0.530 In
Mated Height (mm)	13.45 mm
Material - Metal	Brass
Material - Plating Mating	Tin
Material - Plating Termination	Tin
Material - Resin	Nylon
Number of Rows	1
Orientation	Vertical
PC Tail Length (in)	0.130 In
PC Tail Length (mm)	3.30 mm
PCB Locator	Yes
PCB Retention	Yes
PCB Thickness Recommended (in)	0.062 In
PCB Thickness Recommended (mm)	1.60 mm
Packaging Type	Tray
Pitch - Mating Interface (in)	0.079 In
Pitch - Mating Interface (mm)	2.00 mm
Plating min: Mating (µin)	40
Plating min: Mating (µm)	1.00
Plating min: Termination (µin)	40
Plating min: Termination (µm)	1.00
Polarized to Mating Part	Yes
Shrouded	Fully
Stackable	No
Surface Mount Compatible (SMC)	No
Temperature Range - Operating	-25°C to +85°C
Termination Interface: Style	Through Hole

**Electrical**

Current - Maximum per Contact	2.5A
-------------------------------	------

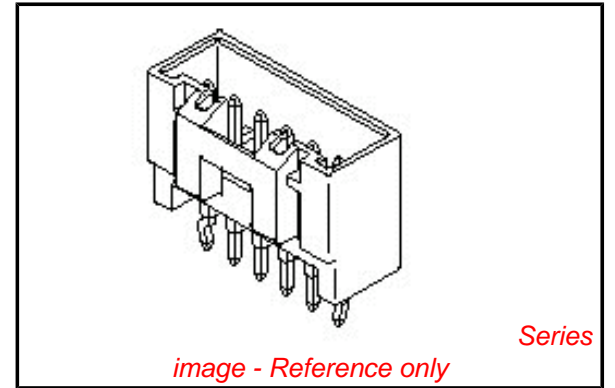

*image - Reference only*

**EU RoHS**

**ELV and RoHS  
Compliant**

**REACH SVHC**

Not Reviewed

**Halogen-Free**

**Status**

**Not Halogen-Free**

**China RoHS**



**Need more information on product  
environmental compliance?**

Email [productcompliance@molex.com](mailto:productcompliance@molex.com)  
 For a multiple part number RoHS Certificate of Compliance, [click here](#)

Please visit the [Contact Us](#) section for any non-product compliance questions.

**Search Parts in this Series**

[55755Series](#)

**Mates With**

[51216](#) Wire-to-Board and Wire-to-Wire Receptacle Housing

Voltage - Maximum

250V

**Material Info**

**Reference - Drawing Numbers**

Product Specification  
Sales Drawing

PS-51216-007, RPS-51216-008, RPS-51216-011  
SD-55755-005

This document was generated on 04/07/2010

**PLEASE CHECK [WWW.MOLEX.COM](http://WWW.MOLEX.COM) FOR LATEST PART INFORMATION**

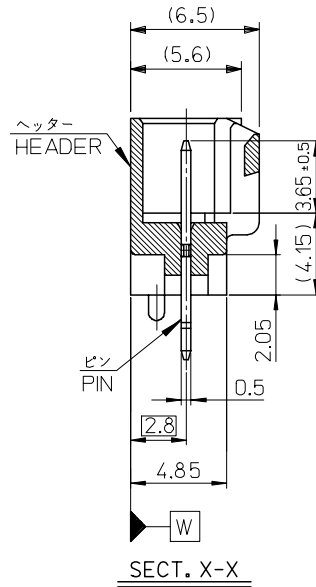
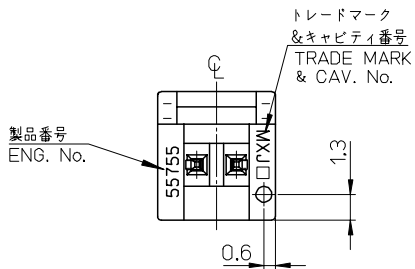
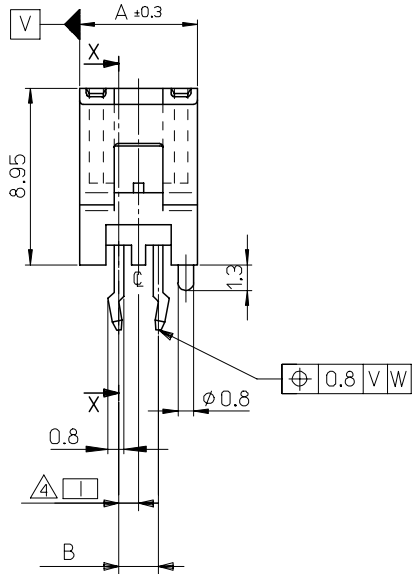
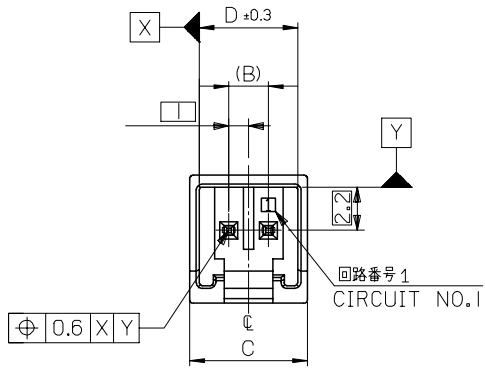

注記  
NOTES

1. 材料 MATERIAL  
 ピン : 黄銅, 銅下地 錫メッキ  
 PIN : BRASS, TIN OVER CU PLATED  
 ヘッダー : 66ナイロン (ガラス入り: 20%), UL94V-0  
 (色: 自然色)  
 HEADER : NYLON6(G.F.: 20%), UL94V-0  
 (COLOR: NATURAL)
2. 嵌合相手 : 51216シリーズ  
 MATE WITH : 51216 SERIES
3. ソルダータールキンは、両端のピンのみとする。  
 KINK TO BE APPLIED FOR 2 PINS AT BOTH ENDS.
4. 偶数極に適用。  
 APPLY EVEN CIRCUIT PRODUCTS.
5. 本製品は 55755-\*\*10 の鉛フリー品である。  
 THIS PRODUCT IS LEAD FREE OF 55755-\*\*10.

5	6	2	6	55755-0219	2
D	C	B	A	MATERIAL NO.	CKT.

55755-\*\*19 MODEL NO.

RELEASED EC NO: J2005-2113 DRAWN: NABE I CHKD: K. TOYODA APPR: NUKITA	GENERAL TOLERANCES (UNLESS SPECIFIED)		DIMENSION STYLE MM ONLY		SCALE 4:1	DESIGN UNITS METRIC	THIRD ANGLE PROJECTION
	10 UNDER	±0.2	DRAWN BY	DATE	TITLE		
	10 OVER 30 UNDER	±0.25	M. NABE I	'05/01/24	2.0 MM WIRE TO BOARD CONN. HEADER ASSY (ST) -LEAD FREE-		
	30 OVER	±0.3	CHECKED BY	DATE	MOLEX INCORPORATED		
0	ANGULAR ±3 °	DRAFT WHERE APPLICABLE MUST REMAIN WITHIN DIMENSIONS	APPROVED BY	DATE	MATERIAL NO.	DOCUMENT NO.	SHEET NO.
			N. UKITA	'05/01/24	SEE CHART	SD-55755-005	1 OF 3
			THIS DRAWING CONTAINS INFORMATION THAT IS PROPRIETARY TO MOLEX INCORPORATED AND SHOULD NOT BE USED WITHOUT WRITTEN PERMISSION				

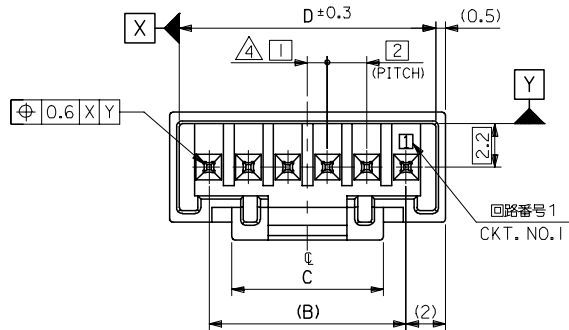

3極以上品

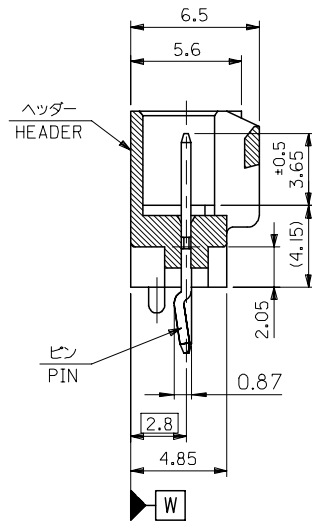
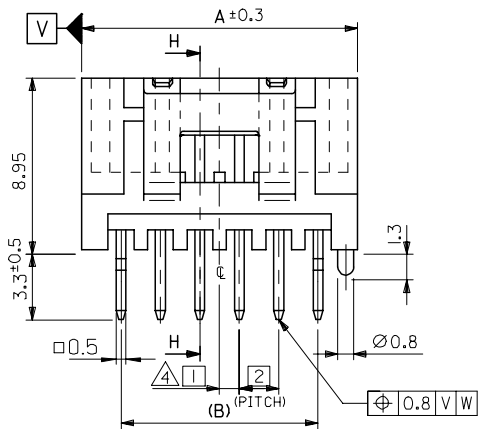

SECT H-H

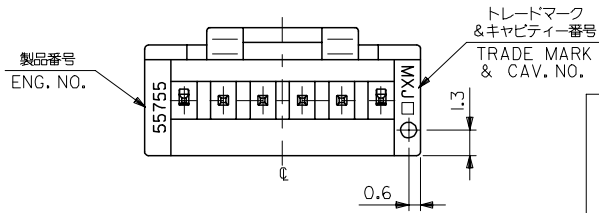

31	7.7	28	32	55755-1519	15
29		26	30	-1419	14
27		24	28	-1319	13
25		22	26	-1219	12
23		20	24	-1119	11
21		18	22	-1019	10
19		16	20	-0919	9
17		14	18	-0819	8
15		12	16	-0719	7
13		10	14	-0619	6
11		8	12	-0519	5
9		6	10	-0419	4
7	7.7	4	8	55755-0319	3
D	C	B	A	MATERIAL NO.	CKT.

RELEASED EC NO: J2005-2113 DRAWN: NABE I CHKD: K. TOYODA APPR: NUKITA	2005/01/24 2005/01/25 2005/01/28	GENERAL TOLERANCES (UNLESS SPECIFIED)		DIMENSION STYLE MM ONLY		SCALE 4:1	DESIGN UNITS METRIC	THIRD ANGLE PROJECTION		
		10 UNDER	±0.2	DRAWN BY M. NABE I	DATE '05/01/24	TITLE 2.0 MM WIRE TO BOARD CONN. HEADER ASSY (ST) -LEAD FREE-				
		10 OVER 30 UNDER	±0.25	CHECKED BY K. TOYODA	DATE '05/01/24	MOLEX INCORPORATED				
		30 OVER	±0.3	APPROVED BY N. UKITA	DATE '05/01/24	DOCUMENT NO. SD-55755-005				
0	DESCRIPTION GENERAL TOLERANCES (UNLESS SPECIFIED)	ANGULAR ±3 °	DRAFT WHERE APPLICABLE MUST REMAIN WITHIN DIMENSIONS		MATERIAL NO. SEE CHART		SHEET NO. 2 OF 3	THIS DRAWING CONTAINS INFORMATION THAT IS PROPRIETARY TO MOLEX INCORPORATED AND SHOULD NOT BE USED WITHOUT WRITTEN PERMISSION		

10

9

8

7

6

5

4

3

2

1

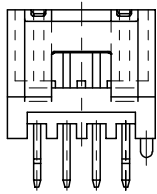

4 CKTS.

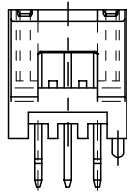

3 CKTS.

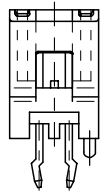

2 CKTS.

標準レイアウト図

LAYOUT OF EACH CKTS.

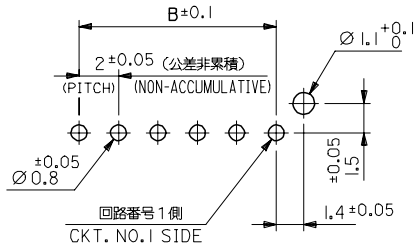

基板取付穴推奨寸法 (マウント面)

RECOMMENDED P.C.BOARD HOLE DIMENSION (MOUNTING SIDE) (t = 1.6)

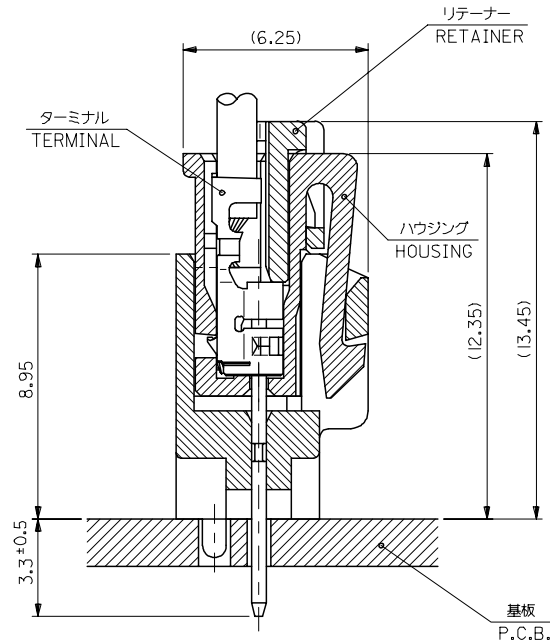

嵌合断面図 (参考)

MATED DRAWING (REF.)

RELEASED EC NO: J2005-2113 DRAWN: NABE I CHKD: K. TOYODA APPR: NUKITA 2005/01/24 2005/01/25 2005/01/28	GENERAL TOLERANCES (UNLESS SPECIFIED)		DIMENSION STYLE MM ONLY		SCALE 4:1	DESIGN UNITS METRIC	THIRD ANGLE PROJECTION		
	10 UNDER	± 0.2	DRAWN BY M. NABE I		DATE '05/01/24	TITLE 2.0 MM WIRE TO BOARD CONN. HEADER ASSY (ST) -LEAD FREE-			
	10 OVER 30 UNDER	± 0.25	CHECKED BY K. TOYODA		DATE '05/01/24				
	30 OVER	± 0.3	APPROVED BY N. UKITA		DATE '05/01/24	MOLEX INCORPORATED DOCUMENT NO. SD-55755-005 SHEET NO. 3 OF 3			
	ANGULAR	± 3 °	MATERIAL NO.		DATE				
0	DRAFT WHERE APPLICABLE MUST REMAIN WITHIN DIMENSIONS		SEE SHEET 1,2		THIS DRAWING CONTAINS INFORMATION THAT IS PROPRIETARY TO MOLEX INCORPORATED AND SHOULD NOT BE USED WITHOUT WRITTEN PERMISSION				

9

8

7

6

5

4

3

2