

# mass integrated

global part distribution • product lifecycle partner  
excess inventory management • value-ad service provider



Data sheet provided by Mass Integrated

[massintegrated.com](http://massintegrated.com) • [displayalliance.com](http://displayalliance.com)

Please call +1.978.465.6190  
Email: [sales@massintegrated.com](mailto:sales@massintegrated.com)



ISO 9001: 2008

Mass Integrated complies with all DMCA takedown notices. Please send a formal DMCA Takedown Notice to Mass Integrated Systems, Inc. • 18 Henry Graf Jr. Road, Unit 1 • Newburyport, MA 01950.



**PROPRIETARY NOTE**

THIS SPECIFICATION IS THE PROPERTY OF BOE TFT-LCD SBU AND SHALL NOT BE REPRODUCED OR COPIED WITHOUT THE WRITTEN PERMISSION OF BOE TFT-LCD SBU AND MUST BE RETURNED TO BOE HYDIS UPON ITS REQUEST

**TITLE : HT150X02-100**

**Product Specification**

**Rev. P0**

**BOE TFT-LCD SBU**

**BEIJING BOE OPTOELECTRONICS TECHNOLOGY**

**BOE HYDIS TECHNOLOGY**

<b>SPEC. NUMBER</b> S -	<b>PRODUCT GROUP</b> TFT-LCD	<b>REV.</b> P0	<b>ISSUE DATE</b> 2006.01.17.	<b>PAGE</b> 1 OF 28
----------------------------	---------------------------------	-------------------	----------------------------------	------------------------





京东方  
BOE

PRODUCT GROUP

REV

ISSUE DATE

TFT- LCD PRODUCT

P0

2006.01.17

## Contents

No.	Item	Page
1.0	General Description	4
2.0	Absolute Maximum Ratings	6
3.0	Electrical specifications	7
4.0	Optical specifications	8
5.0	Interface Connection	10
6.0	Signal Timing Specifications	13
7.0	Signal Timing waveforms of Interface Signal	15
8.0	Input Signals, Display Colors & Gray Scale of Colors	17
9.0	Power Sequence	18
10.0	Mechanical Characteristics	19
11.0	Reliability Test	20
12.0	Handling & Cautions	21
13.0	Product Serial Number	22
14.0	Packing	23
15.0	Appendix	25

SPEC. NUMBER

SPEC. TITLE

PAGE

HT150X02-100 Preliminary Product Specification

3 OF 28

## 1.0 GENERAL DESCRIPTION

### 1.1 Introduction

HT150X02-100 is a color active matrix TFT LCD module using amorphous silicon TFT's (Thin Film Transistors) as an active switching devices. This module has a 15.0 inch diagonally measured active area with XGA resolutions (1024 horizontal by 768 vertical pixel array). Each pixel is divided into RED, GREEN, BLUE dots which are arranged in vertical stripe and this module can display 16,194,227 colors. The TFT-LCD panel used for this module is adapted for a low reflection and higher color type.

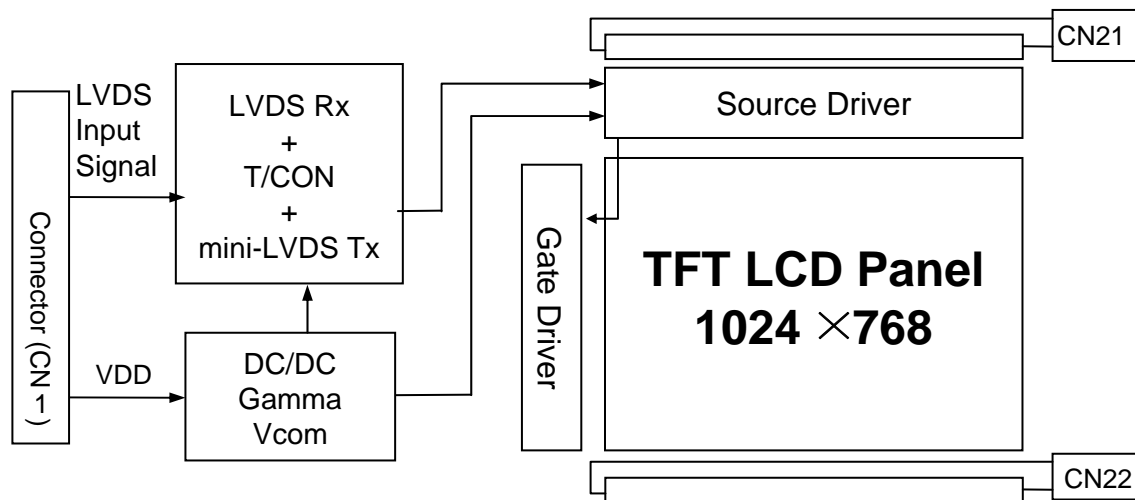

### 1.2 Features

- LVDS Interface with 1 pixel / clock
- High-speed response
- Low power consumption
- 6-bit (FRC) color depth, display 16,194,227 colors
- Incorporated edge type back-light (Two lamps)
- High luminance and contrast ratio, low reflection and wide viewing angle
- DE (Data Enable) & H-Sync & V-Sync mode
- RoHS Compliant

SPEC. NUMBER	SPEC. TITLE	PAGE
	HT150X02-100 Preliminary Product Specification	4 OF 28



PRODUCT GROUP

REV

ISSUE DATE

TFT- LCD PRODUCT

P0

2006.01.17

1.3 Application

- Desktop Type of PC & Workstation Use
- Slim-Size Display for Stand-alone Monitor
- Display Terminals for Control System
- Monitors for Process Controller

1.4 General Specification

The followings are general specifications at the model HT150X02-100.

<Table 1. General Specifications>

Parameter	Specification	Unit	Remarks
Active area	304.128(H) × 228.096(V)	mm	
Number of pixels	1024(H) × 768(V)	pixels	
Pixel pitch	0.297(H) × 0.297(V)	mm	
Pixel arrangement	RGB Vertical stripe		
Display colors	16,194,227	colors	
Display mode	Normally White		
Dimensional outline	326.5(H) × 253.5(V) × 11.2(D) typ.	mm	
Weight	1250 (typ.)	g	
Surface Treatment	Haze 25%, 3H		
Back-light	Top/Bottom side, 2-CCFL type		

SPEC. NUMBER

SPEC. TITLE

HT150X02-100 Preliminary Product Specification

PAGE

5 OF 28

## 2.0 ABSOLUTE MAXIMUM RATINGS

The followings are maximum values which, if exceed, may cause faulty operation or damage to the unit. The operational and non-operational maximum voltage and current values are listed in Table 2.

< Table 2. Absolute Maximum Ratings >

[VSS=GND=0V]

Parameter	Symbol	Min.	Max.	Unit	Remarks
Power Supply Voltage	$V_{DD}$	VSS-0.3	4.0	V	Ta = 25 °C
Logic Supply Voltage	$V_{IN}$	VSS-0.3	$V_{DD}+0.3$	V	
Back-light Lamp Current	$I_{BL}$	3	8	mA	
Back-light Lamp frequency	$F_L$	30	80	kHz	
Operating Temperature	$T_{OP}$	0	+50	°C	1)
Storage Temperature	$T_{ST}$	-20	+60	°C	1)

Note : 1) Temperature and relative humidity range are shown in the figure below.

Wet bulb temperature should be 39 °C max. and no condensation of water.

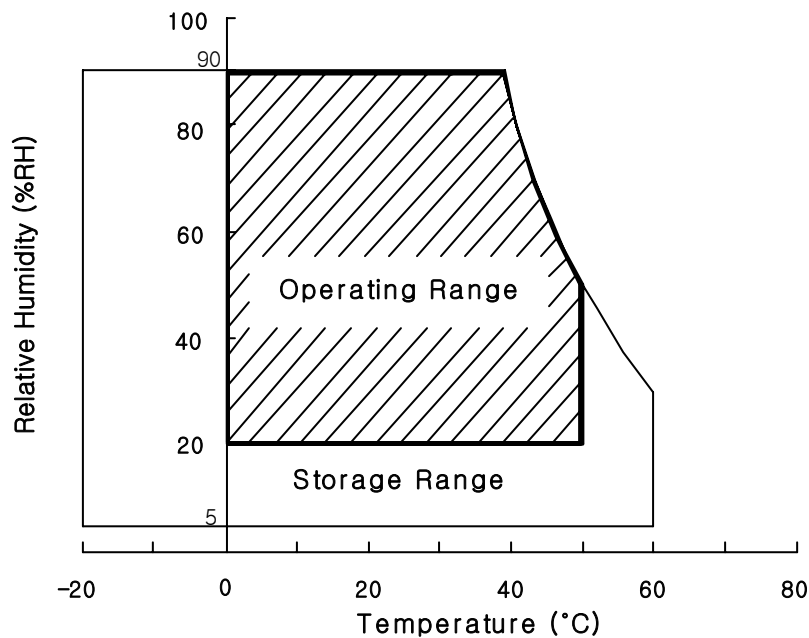



# PRODUCT GROUP

REV

ISSUE DATE

TFT- LCD PRODUCT

P0

2006.01.17

## 3.0 ELECTRICAL SPECIFICATIONS

### 3.1 Electrical Specifications

< Table 3. Electrical specifications >

[Ta =25±2 °C]

Parameter		Min.	Typ.	Max.	Unit	Remarks
Power Supply Voltage	V <sub>DD</sub>	3.0	3.3	3.6	V	Note1
Power Supply Current	I <sub>DD</sub>	-	700	1000	mA	
In Rush Current	I <sub>rush</sub>	-	2.0	3.0	A	Note 2
Permissible Input Ripple Voltage	V <sub>RF</sub>			100	mV	V <sub>DD</sub> = 5.0V
High Level Differential Input Threshold Voltage	V <sub>IH</sub>		-	+100	mV	V <sub>cm</sub> = 1.2V typ.
Low Level Differential Input Threshold Voltage	V <sub>IL</sub>	-100	-		mV	
Back-light Lamp Voltage	V <sub>BL</sub>	500	640	800	V <sub>rms</sub>	
Back-light Lamp Current	I <sub>BL</sub>	3.0	8.0	9.0	mA <sub>rms</sub>	
Back-light Lamp operating Frequency	F <sub>L</sub>	40	-	80	KHz	Note 3
Lamp Start Voltage				1400	V <sub>rms</sub>	25°C, Note 4
				1700	V <sub>rms</sub>	0°C, Note 4
Lamp Life		40000	50000		Hrs	I <sub>BL</sub> = 8.0mA
Power Consumption	P <sub>D</sub>	-	2.3	3.3	W	
	P <sub>BL</sub>		10.24	←	W	I <sub>BL</sub> = 8.0mA, Note 5
	P <sub>total</sub>		21.6	23.1	W	

- Notes :
- The supply voltage is measured and specified at the interface connector of LCM.  
The current draw and power consumption specified is for VDD=5.0V, Frame rate=75Hz and Clock frequency = 67.5MHz. Test Pattern of power supply current  
a) Typ : Color Bar pattern  
b) Max : Dot pattern
  - Duration of rush current is about 2 ms and rising time of VDD is 520 μs ± 20 %
  - The lamp frequency should be selected as different as possible from the horizontal synchronous frequency and its harmonics to avoid interference, which may cause line flow on the display
  - The voltage above this value should be applied to the lamps for more than 1 second to start-up. Otherwise the lamps may not be turned on.
  - Calculated value for reference (V<sub>BL</sub> × I<sub>BL</sub>) × 4 excluding inverter loss.

SPEC. NUMBER

SPEC. TITLE

PAGE

HT150X02-100 Preliminary Product Specification

7 OF 28





# PRODUCT GROUP

REV

ISSUE DATE

TFT- LCD PRODUCT

P0

2006.01.17

## 4.0 OPTICAL SPECIFICATION

### 4.1 Overview

The test of Optical specifications shall be measured in a dark room (ambient luminance  $\leq 1$  lux and temperature =  $25 \pm 2^\circ\text{C}$ ) with the equipment of Luminance meter system (Goniometer system and TOPCONE BM-5) and test unit shall be located at an approximate distance 50cm from the LCD surface at a viewing angle of  $\theta$  and  $\phi$  equal to  $0^\circ$ . We refer to  $\theta_{\phi=0}$  ( $=\theta_3$ ) as the 3 o'clock direction (the "right"),  $\theta_{\phi=90}$  ( $=\theta_{12}$ ) as the 12 o'clock direction ("upward"),  $\theta_{\phi=180}$  ( $=\theta_9$ ) as the 9 o'clock direction ("left") and  $\theta_{\phi=270}$  ( $=\theta_6$ ) as the 6 o'clock direction ("bottom"). While scanning  $\theta$  and/or  $\phi$ , the center of the measuring spot on the Display surface shall stay fixed. The measurement shall be executed after 30 minutes warm-up period. VDD shall be 5.0V +/-10% at  $25^\circ\text{C}$ . Optimum viewing angle direction is 6 'clock.

### 4.2 Optical Specifications

[VDD = 5.0V, Frame rate = 60Hz, Clock = 54MHz,  $I_{BL} = 8.0\text{mA}$ ,  $T_a = 25 \pm 2^\circ\text{C}$ ]

Parameter		Symbol	Condition	Min.	Typ.	Max.	Unit	Remark
Viewing Angle range	Horizontal	$\theta_3$	CR > 10	65	75	-	Deg.	Note 1
		$\theta_9$		65	75	-	Deg.	
	Vertical	$\theta_{12}$		60	70	-	Deg.	
		$\theta_6$		50	60	-	Deg.	
Viewing Angle range	Horizontal	$\theta_3$	CR > 5	70	80	-	Deg.	
		$\theta_9$		70	80	-	Deg.	
	Vertical	$\theta_{12}$		70	80	-	Deg.	
		$\theta_6$		70	80	-	Deg.	
Luminance Contrast ratio		CR		400	500			Note 2
Luminance of White		$Y_w$		200	250		cd/m <sup>2</sup>	Note 3
White luminance uniformity		$\Delta Y$		75	80		%	Note 4
Reproduction of color	White	$W_x$		$\theta = 0^\circ$ (Center) Normal Viewing Angle	0.283	0.313	0.343	
		$W_y$	0.299		0.329	0.359		
	Red	$R_x$			TBD			
		$R_y$			TBD			
	Green	$G_x$			TBD			
		$G_y$			TBD			
	Blue	$B_x$			TBD			
		$B_y$			TBD			
Response Time	Rising	$T_r$		2	4	ms	Note 6	
	Falling	$T_f$		6	8	ms		
Cross Talk		CT		-	-	2.0	%	Note 7

SPEC. NUMBER

SPEC. TITLE

PAGE

HT150X02-100 Preliminary Product Specification

8 OF 28



PRODUCT GROUP

REV

ISSUE DATE

TFT- LCD PRODUCT

P0

2006.01.17

Note :

- 1. Viewing angle is the angle at which the contrast ratio is greater than 10. The viewing are determined for the horizontal or 3, 9 o'clock direction and the vertical or 6, 12 o'clock direction with respect to the optical axis which is normal to the LCD surface.
- 2. Contrast measurements shall be made at viewing angle of  $\theta = 0^\circ$  and at the center of the LCD surface. Luminance shall be measured with all pixels in the view field set first to white, then to the dark (black) state. (See FIGURE 1 shown in Appendix) Luminance Contrast Ratio (CR) is defined mathematically.

$$CR = \frac{\text{Luminance when displaying a white raster}}{\text{Luminance when displaying a black raster}}$$

- 3. Center Luminance of white is defined as the LCD surface. Luminance shall be measured with all pixels in the view field set first to white. This measurement shall be taken at the locations shown in FIGURE 2 for a total of the measurements per display.
- 4. The White luminance uniformity on LCD surface is then expressed as :  
 $\Delta Y = ( \text{Minimum Luminance of 9points} / \text{Maximum Luminance of 9points} ) * 100$   
 (See FIGURE 2 shown in Appendix).
- 5. The color chromaticity coordinates specified in Table 4. shall be calculated from the spectral data measured with all pixels first in red, green, blue and white. Measurements shall be made at the center of the panel.
- 6. The electro-optical response time measurements shall be made as FIGURE 3 shown in Appendix by switching the "data" input signal ON and OFF. The times needed for the luminance to change from 10% to 90% is Td, and 90% to 10% is Tr.
- 7. Cross-Talk of one area of the LCD surface by another shall be measured by comparing the luminance ( $Y_A$ ) of a 25mm diameter area, with all display pixels set to a gray level, to the luminance ( $Y_B$ ) of that same area when any adjacent area is driven dark. (See FIGURE 4 shown in Appendix).

SPEC. NUMBER	SPEC. TITLE HT150X02-100 Preliminary Product Specification	PAGE 9 OF 28
--------------	---	-----------------



# PRODUCT GROUP

REV

ISSUE DATE

TFT- LCD PRODUCT

P0

2006.01.17

## 5.0 INTERFACE CONNECTION.

### 5.1 Electrical Interface Connection

- CN11 : Module Side Connector : DF14H-20P-1.25H (Hirose) or Equivalent  
User Side Connector : DF14-20S-1.25C (Hirose) or equivalent

Pin No	Symbol	Function	Remark
1	VDD	Power Supply, 3.3V (typical)	
2	VDD	Power Supply, 3.3V (typical)	
3	VSS	Ground	
4	VSS	Ground	
5	RIN0-	- LVDS differential data input (R0-R5, G0)	
6	RIN0+	+ LVDS differential data input (R0-R5, G0)	
7	VSS	Ground	
8	RIN1-	- LVDS differential data input (G1-G5, B0-B1)	
9	RIN1+	+ LVDS differential data input (G1-G5, B0-B1)	
10	VSS	Ground	
11	RIN2-	- LVDS differential data input (B2-B5, HS, VS, DE)	
12	RIN2+	+ LVDS differential data input (B2-B5, HS, VS, DE)	
13	VSS	Ground	
14	CLKIN-	- LVDS differential clock input	
15	CLKIN+	+ LVDS differential clock input	
16	VSS	Ground	
17	RIN3-	- LVDS differential data input (R6-R7, G6-G7, B6-B7)	
18	RIN3+	+ LVDS differential data input (R6-R7, G6-G7, B6-B7)	
19	VSS	Ground	
20	VSS	Ground	

SPEC. NUMBER

SPEC. TITLE

PAGE

HT150X02-100 Preliminary Product Specification

10 OF 28



京东方  
BOE

PRODUCT GROUP

REV

ISSUE DATE

TFT- LCD PRODUCT

P0

2006.01.17

5.2 LVDS Interface (Tx; THC63LVDF83A or Equivalent)

Input Signal	Transmitter		Interface		DF14H-20P-1.25H	Remark
	Pin No.	Pin No.	System (Tx)	TFT-LCD (Rx)	Pin No.	
OR0	51	48 47	OUT0- OUT0+	IN0- IN0+	5 6	
OR1	52					
OR2	54					
OR3	55					
OR4	56					
OR5	3					
OG0	4	46 45	OUT1- OUT1+	IN1- IN1+	8 9	
OG1	6					
OG2	7					
OG3	11					
OG4	12					
OG5	14					
OB0	15	42 41	OUT2- OUT2+	IN2- IN2+	11 12	
OB1	19					
OB2	20					
OB3	22					
OB4	23					
OB5	24					
Hsync	27	40 39	CLK OUT- CLK OUT+	CLKIN- CLKIN+	14 15	
Vsync	28					
DE	30					
MCLK	31					
OR6	50					
OR7	2					
OG6	8	38 37	OUT3- OUT3+	IN3- IN3+	17 18	
OG7	10					
OB6	16					
OB7	18					
RSVD	25					

SPEC. NUMBER

SPEC. TITLE

PAGE

HT150X02-100 Preliminary Product Specification

11 OF 28



# PRODUCT GROUP

REV

ISSUE DATE

TFT- LCD PRODUCT

P0

2006.01.17

## 5.3 Data Input Format

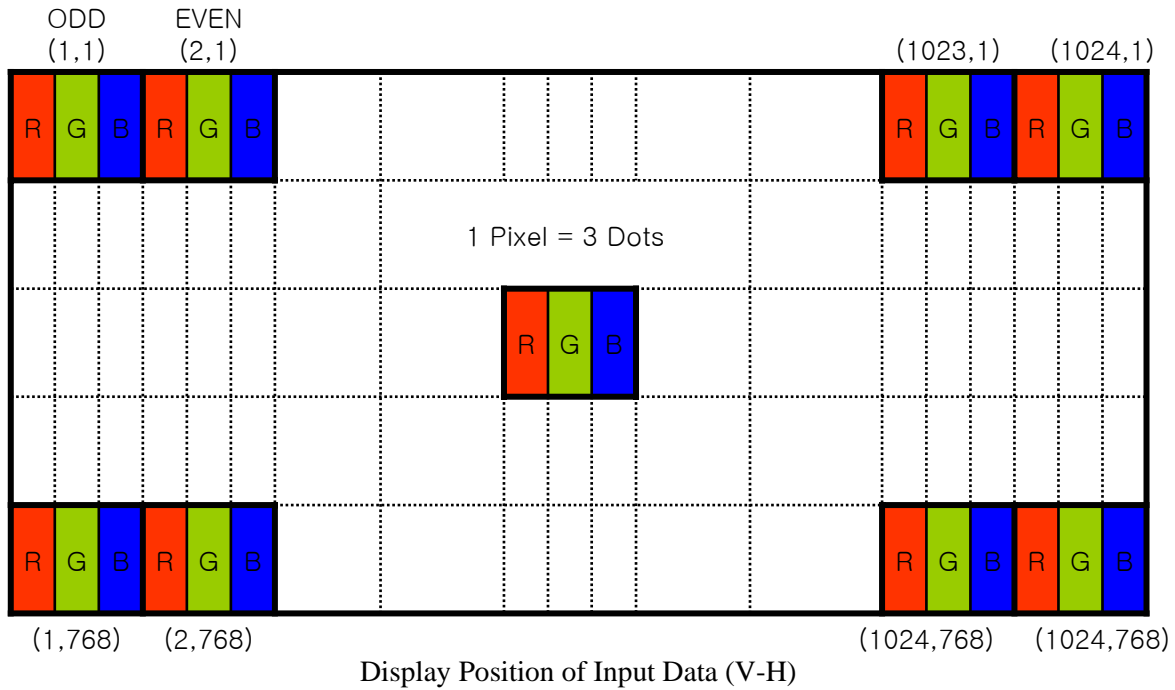

Display Position of Input Data (V-H)

## 5.4 Back-light Interface Connection

● CN 21,22 Module Side Connector :BHSR-03VS-1 or Equivalent  
User Side Connector :

PIN NO.	INPUT	COLOR	FUNCTION
1	HOT	Blue	High Voltage
2	COLD	Black	Ground

SPEC. NUMBER

SPEC. TITLE

PAGE

HT150X02-100 Preliminary Product Specification

12 OF 28



# PRODUCT GROUP

REV

ISSUE DATE

TFT- LCD PRODUCT

P0

2006.01.17

## 6.0 SIGNAL TIMING SPECIFICATION

6.1 The HT150X02-100 is operated by the DE & H-Sync & V-Sync mode ( LVDS Transmitter Input )

Item		Symbols	Min	Typ	Max	Unit
Clock	Frequency	1/Tc	45	65	82	MHz
	High Time	Tch	4.5	-	-	ns
	Low Time	Tcl	4.5	-	-	ns
Data	Setup Time	Tds	2.7	-	-	ns
	Hold Time	Tdh	0	-	-	ns
Data Enable Setup Time		Tes	2.7	-	-	ns
Frame Rate		Fv	50	60	75	Hz
Frame Period		Tv	772	806	1022	lines
Vertical Display Period		Tvd	768	768	768	lines
One Line Scanning Period		Th	1100	1344	2046	clocks
Horizontal Display Period		Thd	1024	1024	1024	clocks

SPEC. NUMBER

SPEC. TITLE

PAGE

HT150X02-100 Preliminary Product Specification

13 OF 28

### 6.2 LVDS Rx Interface Timing Parameter

The specification of the LVDS Rx interface timing parameter is shown in Table 4.

<Table 4. LVDS Rx Interface Timing Specification>

Item	Symbol	Min	Typ	Max	Unit	Remark
CLKIN Period	tRCIP	12.5	15.38	-	msec	
CLK Difference	tCdiff	-tRCIP*(3/7)	0	+tRCIP*(3/7)	nsec	
Input Data 0	tRIP1	-0.4	0.0	+0.4	nsec	
Input Data 1	tRIP0	tRCIP/7-0.4	tRCIP/7	tRCIP/7+0.4	nsec	
Input Data 2	tRIP6	2 × tRCIP/7-0.4	2 × tRCIP/7	2 × tRCIP/7+0.4	nsec	
Input Data 3	tRIP5	3 × tRCIP/7-0.4	3 × tRCIP/7	3 × tRCIP/7+0.4	nsec	
Input Data 4	tRIP4	4 × tRCIP/7-0.4	4 × tRCIP/7	4 × tRCIP/7+0.4	nsec	
Input Data 5	tRIP3	5 × tRCIP/7-0.4	5 × tRCIP/7	5 × tRCIP/7+0.4	nsec	
Input Data 6	tRIP2	6 × tRCIP/7-0.4	6 × tRCIP/7	6 × tRCIP/7+0.4	nsec	

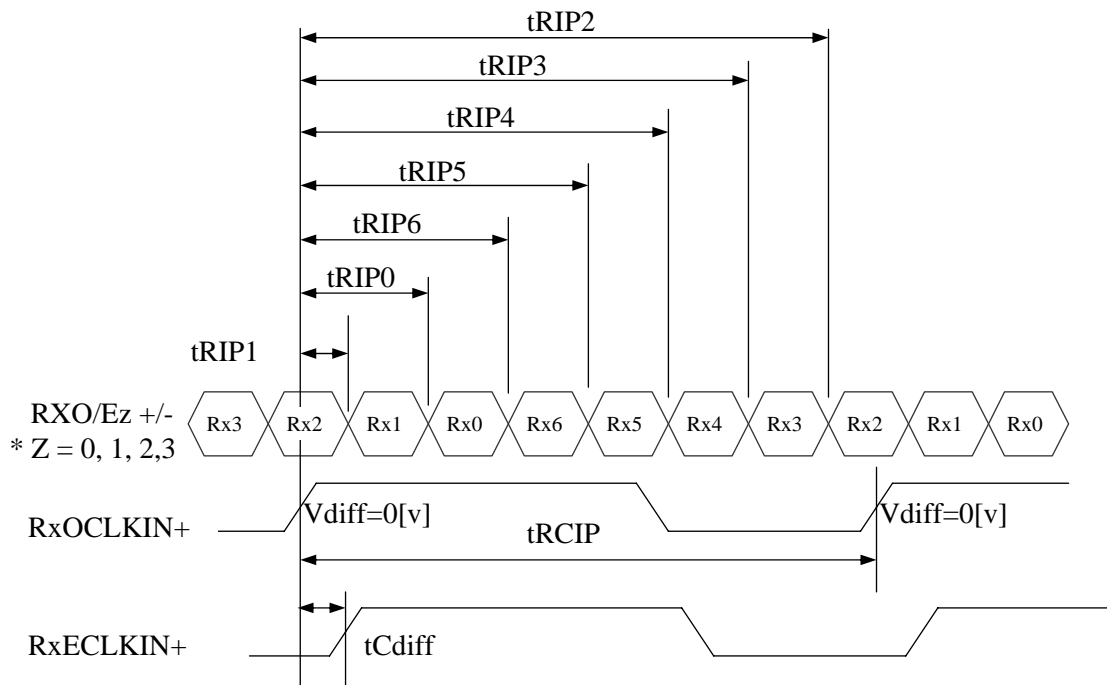

$$* V_{diff} = (RIN_{z+}) - (RIN_{z-}), \dots, (CLKIN_{+}) - (CLKIN_{-})$$

## 7.0 SIGNAL TIMING WAVEFORMS OF INTERFACE SIGNAL

### 7.1 Sync Timing Waveforms

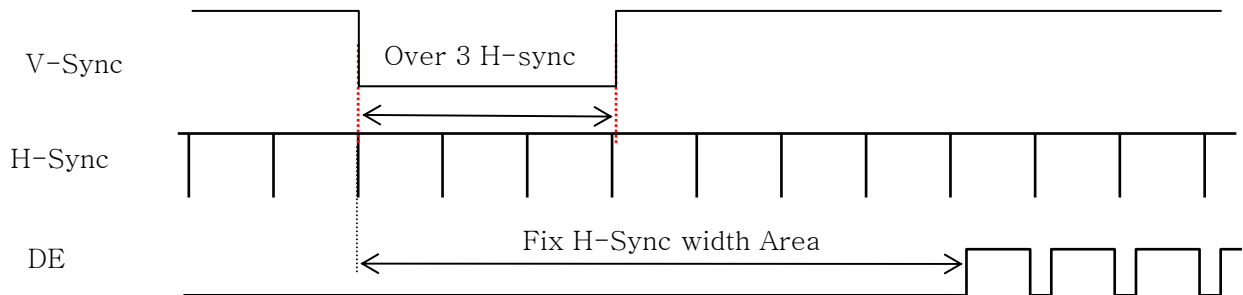

- 1) Need over 3 H-sync during V-Sync Low
- 2) Fix H-Sync width from V-Sync falling edge to first rising edge

### 7.2 Horizontal Timing Waveforms

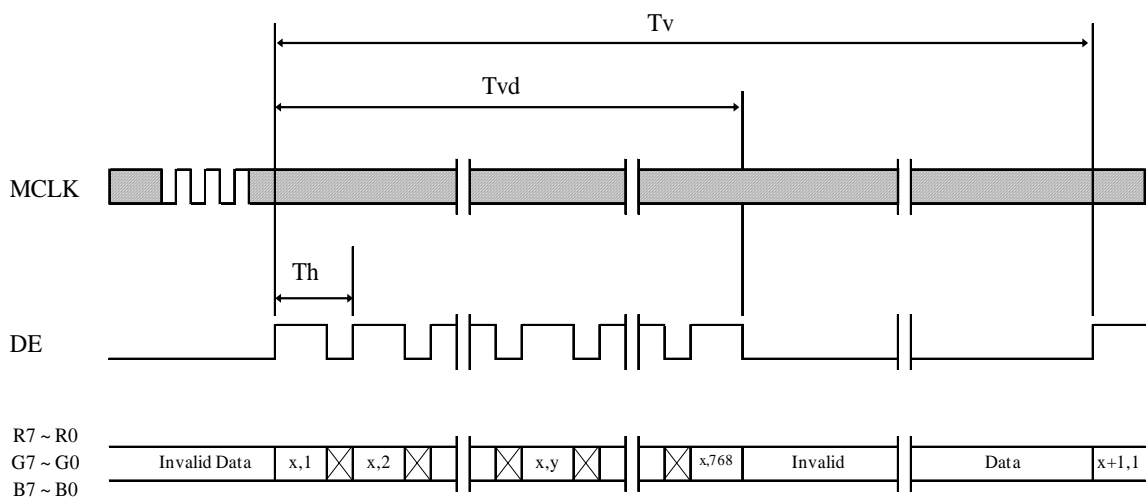

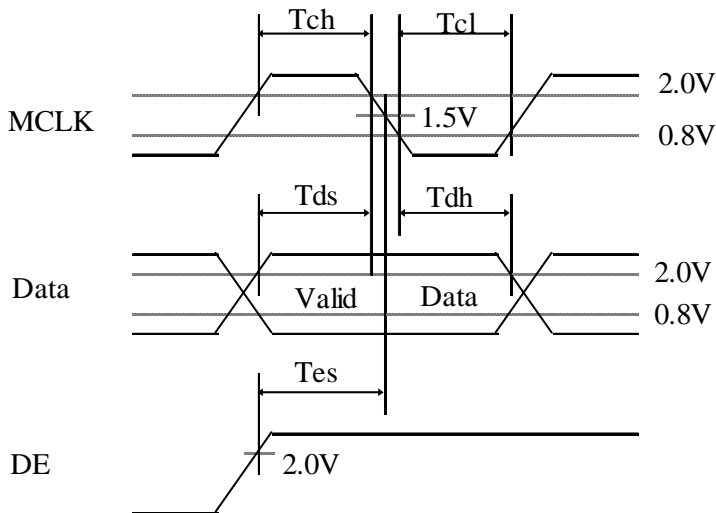
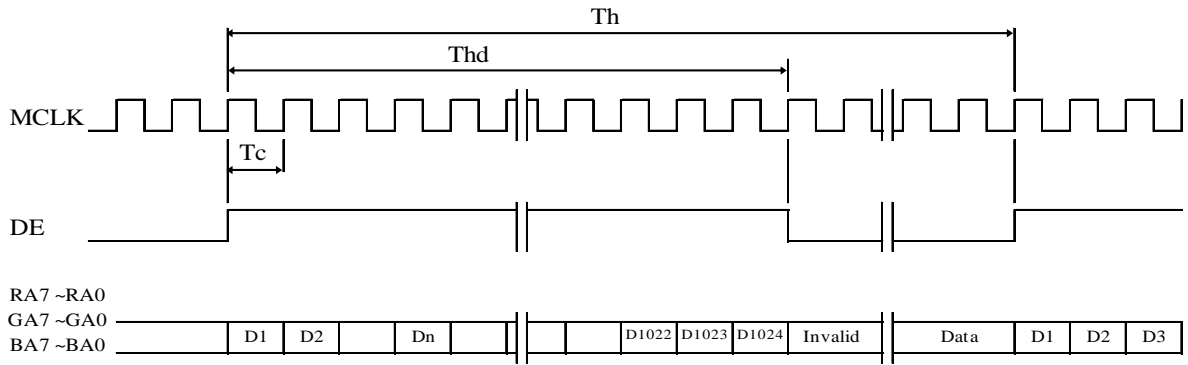

**7.3 Horizontal Timing Waveforms**



**PRODUCT GROUP**

REV

ISSUE DATE

TFT- LCD PRODUCT

P0

2006.01.17

**8.0 INPUT SIGNALS, BASIC DISPLAY COLORS & GRAY SCALE OF COLORS**

Color & Gray Scale		RED DATA								GREEN DATA								BLUE DATA							
		R7	R6	R5	R4	R3	R2	R1	R0	G7	G6	G5	G4	G3	G2	G1	G0	B7	B6	B5	B4	B3	B2	B1	B0
Basic Colors	Black	0	0	0	0	0	0	0	0	0	0	0	0	0	0	0	0	0	0	0	0	0	0	0	0
	Blue	0	0	0	0	0	0	0	0	0	0	0	0	0	0	0	0	1	1	1	1	1	1	1	1
	Green	0	0	0	0	0	0	0	0	1	1	1	1	1	1	1	1	0	0	0	0	0	0	0	0
	Cyan	0	0	0	0	0	0	0	0	1	1	1	1	1	1	1	1	1	1	1	1	1	1	1	1
	Red	1	1	1	1	1	1	1	1	0	0	0	0	0	0	0	0	0	0	0	0	0	0	0	0
	Magenta	1	1	1	1	1	1	1	1	0	0	0	0	0	0	0	0	1	1	1	1	1	1	1	1
	Yellow	1	1	1	1	1	1	1	1	1	1	1	1	1	1	1	1	0	0	0	0	0	0	0	0
	White	1	1	1	1	1	1	1	1	1	1	1	1	1	1	1	1	1	1	1	1	1	1	1	1
Gray Scale of RED	Black	0	0	0	0	0	0	0	0	0	0	0	0	0	0	0	0	0	0	0	0	0	0	0	0
	△	0	0	0	0	0	0	1	0	0	0	0	0	0	0	0	0	0	0	0	0	0	0	0	0
	Darker	0	0	0	0	0	0	1	0	0	0	0	0	0	0	0	0	0	0	0	0	0	0	0	0
	△	↑								↑								↑							
	▽	↓								↓								↓							
	Brighter	1	1	1	1	1	1	0	1	0	0	0	0	0	0	0	0	0	0	0	0	0	0	0	0
	▽	1	1	1	1	1	1	0	0	0	0	0	0	0	0	0	0	0	0	0	0	0	0	0	0
	Red	1	1	1	1	1	1	1	1	0	0	0	0	0	0	0	0	0	0	0	0	0	0	0	0
Gray Scale of GREEN	Black	0	0	0	0	0	0	0	0	0	0	0	0	0	0	0	0	0	0	0	0	0	0	0	0
	△	0	0	0	0	0	0	0	0	0	0	0	0	0	0	0	1	0	0	0	0	0	0	0	0
	Darker	0	0	0	0	0	0	0	0	0	0	0	0	0	0	1	0	0	0	0	0	0	0	0	0
	△	↑								↑								↑							
	▽	↓								↓								↓							
	Brighter	0	0	0	0	0	0	0	0	1	1	1	1	1	1	0	1	0	0	0	0	0	0	0	0
	▽	0	0	0	0	0	0	0	0	1	1	1	1	1	1	0	0	0	0	0	0	0	0	0	0
	Green	0	0	0	0	0	0	0	0	1	1	1	1	1	1	1	1	0	0	0	0	0	0	0	0
Gray Scale of BLUE	Black	0	0	0	0	0	0	0	0	0	0	0	0	0	0	0	0	0	0	0	0	0	0	0	0
	△	0	0	0	0	0	0	0	0	0	0	0	0	0	0	0	0	0	0	0	0	0	0	0	1
	Darker	0	0	0	0	0	0	0	0	0	0	0	0	0	0	0	0	0	0	0	0	0	0	1	0
	△	↑								↑								↑							
	▽	↓								↓								↓							
	Brighter	0	0	0	0	0	0	0	0	0	0	0	0	0	0	0	0	1	1	1	1	1	1	0	1
	▽	0	0	0	0	0	0	0	0	0	0	0	0	0	0	0	0	1	1	1	1	1	1	1	0
	Blue	0	0	0	0	0	0	0	0	0	0	0	0	0	0	0	0	1	1	1	1	1	1	1	1
Gray Scale of WHITE	Black	0	0	0	0	0	0	0	0	0	0	0	0	0	0	0	0	0	0	0	0	0	0	0	0
	△	0	0	0	0	0	0	1	0	0	0	0	0	0	0	0	1	0	0	0	0	0	0	0	1
	Darker	0	0	0	0	0	0	1	0	0	0	0	0	0	0	1	0	0	0	0	0	0	0	1	0
	△	↑								↑								↑							
	▽	↓								↓								↓							
	Brighter	1	1	1	1	1	1	0	1	1	1	1	1	1	1	0	1	1	1	1	1	1	1	0	1
	▽	1	1	1	1	1	1	0	1	1	1	1	1	1	1	0	1	1	1	1	1	1	1	1	0
	White	1	1	1	1	1	1	1	1	1	1	1	1	1	1	1	1	1	1	1	1	1	1	1	1

SPEC. NUMBER

SPEC. TITLE

PAGE

HT150X02-100 Preliminary Product Specification

17 OF 28

## 9.0 POWER SEQUENCE

To prevent a latch-up or DC operation of the LCD module, the power on/off sequence shall be as shown in below

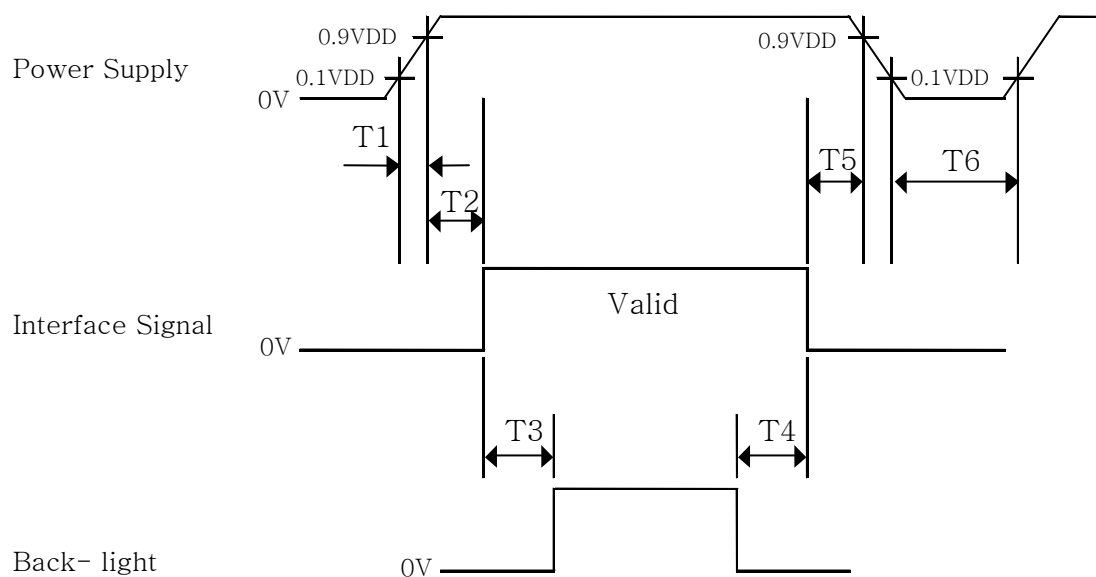

- $0 \leq T1 \leq 10 \text{ ms}$
- $0 \leq T2 \leq 50 \text{ ms}$
- $200\text{ms} \leq T3$
- $0 \leq T4 \leq 50\text{ms}$
- $500\text{ms} \leq T5$

### Notes:

1. When the power supply VDD is 0V, Keep the level of input signals on the low or keep high impedance.
2. Do not keep the interface signal high impedance when power is on. Back Light must be turn on after power for logic and interface signal are valid.



# PRODUCT GROUP

REV

ISSUE DATE

TFT- LCD PRODUCT

P0

2006.01.17

## 10.0 MECHANICAL CHARACTERISTICS

### 10.1 Dimensional Requirements

FIGURE 6 (located in Appendix) shows mechanical outlines for the model HT150X02-100. Other parameters are shown in Table 5.

<Table 5. Dimensional Parameters>

Parameter	Specification	Unit
Dimensional outline	326.5 × 253.5 × 11.2	mm
Weight	1250 (typ..)	gram
Active area	304.128(H) × 228.096(V)	mm
Pixel pitch	0.297(H) × 0.297(V)	mm
Number of pixels	1024(H) × 768(V) (1 pixel = R + G + B dots)	pixels
Back-light	Top / Bottom side 2-CCFL type	

### 10.2 Mounting

See FIGURE 5. (shown in Appendix)

### 10.3 Anti-Glare and Polarizer Hardness.

The surface of the LCD has an anti-glare coating to minimize reflection and a coating to reduce scratching.

### 10.4 Light Leakage

There shall not be visible light from the back-lighting system around the edges of the screen as seen from a distance 50cm from the screen with an overhead light level of 350lux.

SPEC. NUMBER

SPEC. TITLE

PAGE

HT150X02-100 Preliminary Product Specification

19 OF 28



**PRODUCT GROUP**

REV

ISSUE DATE

TFT- LCD PRODUCT

P0

2006.01.17

**11.0 RELIABILITY TEST**

The Reliability test items and its conditions are shown in below.

<Table 6. Reliability Test Parameters >

No	Test Items	Conditions	
1	High temperature storage test	Ta = 60 °C , 240 hrs	
2	Low temperature storage test	Ta = -20 °C , 240 hrs	
3	High temperature & high humidity operation test	Ta = 50 °C , 80%RH, 240hrs	
4	High temperature operation test	Ta = 50 °C , 240hrs	
5	Low temperature operation test	Ta = 0 °C , 240hrs	
6	Thermal shock	Ta = -20 °C ↔ 60 °C (0.5 hr), 100 cycle	
7	Vibration test (non-operating)	Frequency	10 ~ 300 Hz, Sweep rate 30 min
		Gravity / AMP	1.5 G
		Period	± X, ± Y, ± Z 30 min
8	Shock test (non-operating)	Gravity	150G
		Pulse width	6msec, sine wave
		Direction	± X, ± Y, ± Z Once for each
9	Electro-static discharge test (non-operating)	Air : 150 pF, 330Ω, 15 KV	Contact : 150 pF, 330Ω, 8 KV

SPEC. NUMBER

SPEC. TITLE

PAGE

HT150X02-100 Preliminary Product Specification

20 OF 28



## PRODUCT GROUP

REV

ISSUE DATE

TFT- LCD PRODUCT

P0

2006.01.17

### 12.0 HANDLING & CAUTIONS

- (1) Cautions when taking out the module
  - Pick the pouch only, when taking out module from a shipping package.
- (2) Cautions for handling the module
  - As the electrostatic discharges may break the LCD module, handle the LCD module with care. Peel a protection sheet off from the LCD panel surface as slowly as possible.
  - As the LCD panel and back - light element are made from fragile glass material, impulse and pressure to the LCD module should be avoided.
  - As the surface of the polarizer is very soft and easily scratched, use a soft dry cloth without chemicals for cleaning.
  - Do not pull the interface connector in or out while the LCD module is operating.
  - Put the module display side down on a flat horizontal plane.
  - Handle connectors and cables with care.
- (3) Cautions for the operation
  - When the module is operating, do not lose CLK, ENAB signals. If any one of these signals is lost, the LCD panel would be damaged.
  - Obey the supply voltage sequence. If wrong sequence is applied, the module would be damaged.
- (4) Cautions for the atmosphere
  - Dew drop atmosphere should be avoided.
  - Do not store and/or operate the LCD module in a high temperature and/or humidity atmosphere. Storage in an electro-conductive polymer packing pouch and under relatively low temperature atmosphere is recommended.
- (5) Cautions for the module characteristics
  - Do not apply fixed pattern data signal to the LCD module at product aging.
  - Applying fixed pattern for a long time may cause image sticking.
- (6) Other cautions
  - Do not disassemble and/or re-assemble LCD module.
  - Do not re-adjust variable resistor or switch etc.
  - When returning the module for repair or etc., Please pack the module not to be broken. We recommend to use the original shipping packages.

SPEC. NUMBER

SPEC. TITLE

PAGE

HT150X02-100 Preliminary Product Specification

21 OF 28



**PRODUCT GROUP**

REV

ISSUE DATE

TFT- LCD PRODUCT

P0

2006.01.17

**13.0 PRODUCT SERIAL NUMBER**

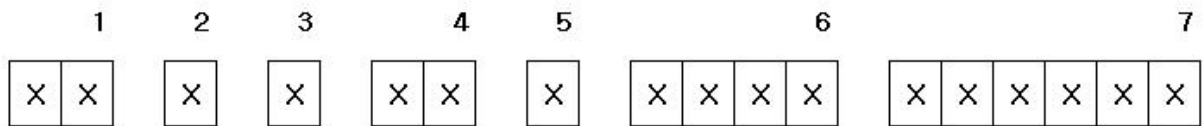

**Type**

No 1. Control

No 2. Rank

No 3. Line Classification(BOE HYDIS : H, LCM : L, BOE OT : A/B/C)

No 4. Year(2001 : 01, 2002 : 02, ...)

No 5. Month(1, 2, 3, ...,9 X, Y, Z)

No 6. FG Code

No 7. Serial No.

SPEC. NUMBER	SPEC. TITLE	PAGE
	HT150X02-100 Preliminary Product Specification	22 OF 28

## 14.0 Packing

### 14.1 Packing Order

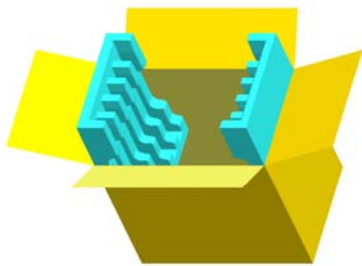

Put pads into the box.

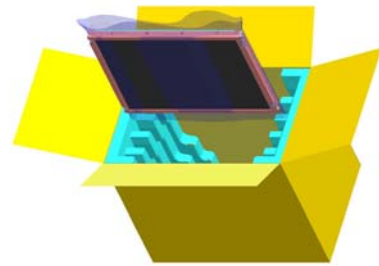

As shown in the figure, place the Modules bundled by shielding bag in the box.



After sealing the box, attach Packing Label on the attach position sign area of the box.

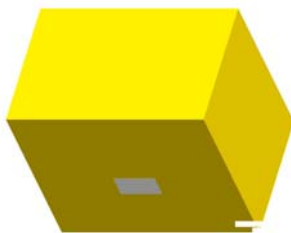

Place a cover on the top of the box.

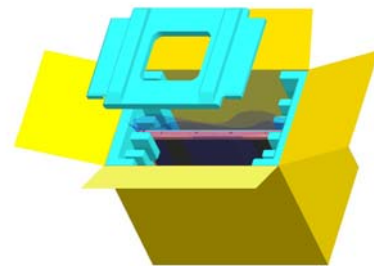





# PRODUCT GROUP

REV

ISSUE DATE

TFT- LCD PRODUCT

P0

2006.01.17

### 14.2 Packing Note

- Box Dimension : 333mm(W) × 333mm(D) × 435mm(H)
- Package Quantity in one Box : 8pcs

### 14.3 Box label

- Label Size : 108 mm (L) × 56 mm (W)
- Contents  
Model : HT150X02  
Q`ty : Module Q`ty in one box  
Serial No. : Box Serial No. See next page for detail description.  
Date : Packing Date  
FG Code : FG Code of Product

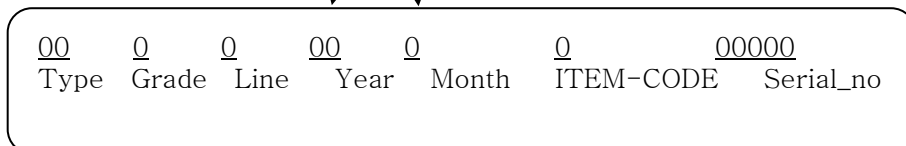
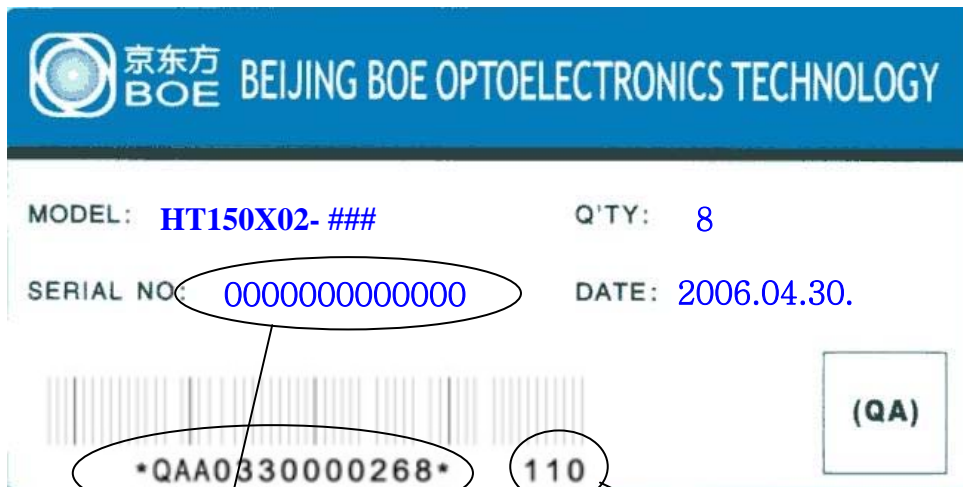

FG CODE

SPEC. NUMBER	SPEC. TITLE	PAGE
	HT150X02-100 Preliminary Product Specification	24 OF 28

15.0 APPENDIX

Figure 1. Measurement Set Up

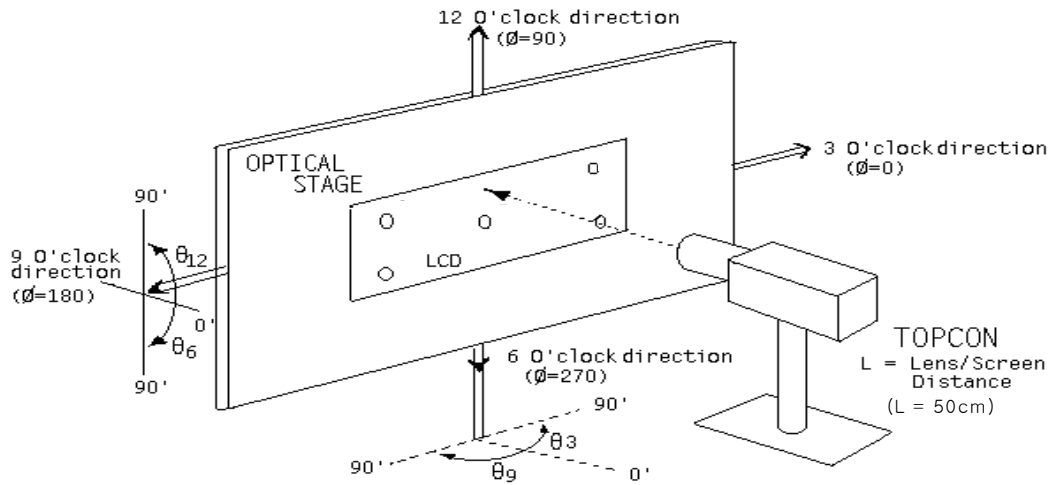
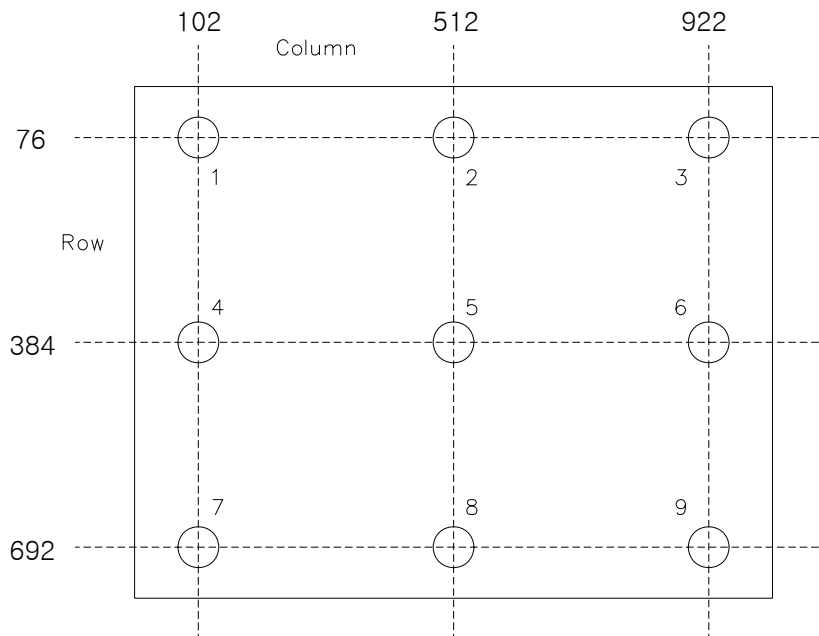
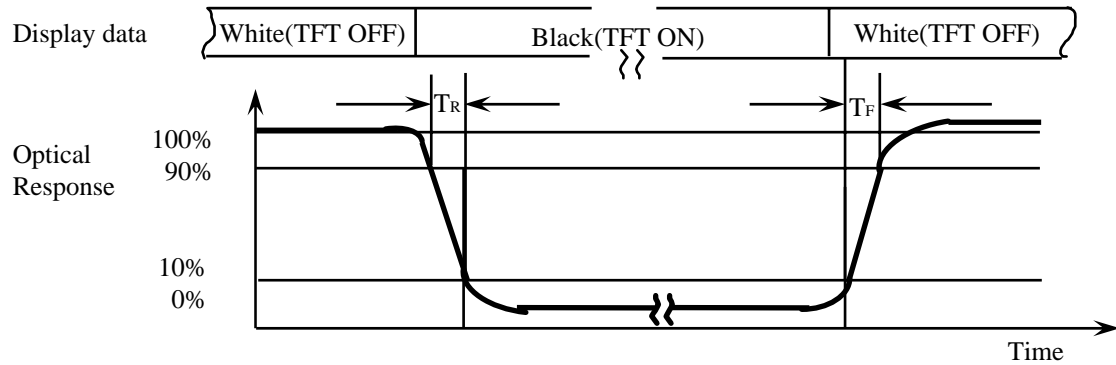
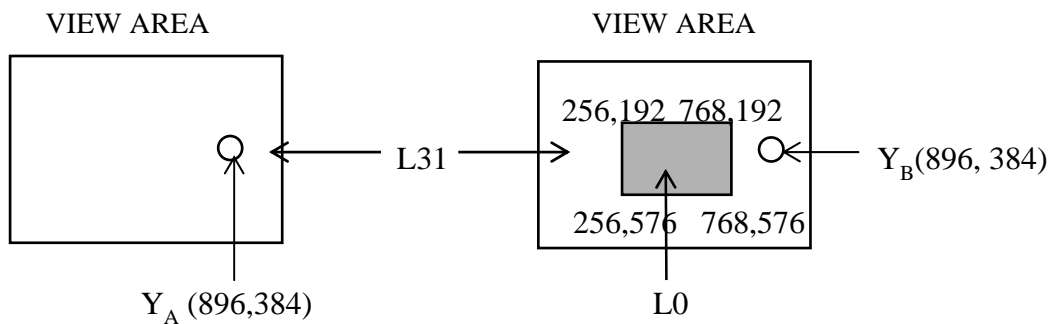

Figure 2. White Luminance and Uniformity Measurement Locations (5 points)



SPEC. NUMBER	SPEC. TITLE HT150X02-100 Preliminary Product Specification	PAGE 25 OF 28
--------------	---	------------------

**Figure 3. Response Time Testing**

**Figure 4. Cross Modulation Test Description**

$$\text{Cross-Talk (\%)} = \left| \frac{Y_B - Y_A}{Y_A} \right| \times 100$$

Where:

$Y_A$  = Initial luminance of measured area (cd/m<sup>2</sup>)

$Y_B$  = Subsequent luminance of measured area (cd/m<sup>2</sup>)

The location measured will be exactly the same in both patterns

Figure 5. TFT-LCD Module Outline Dimensions (Front view)

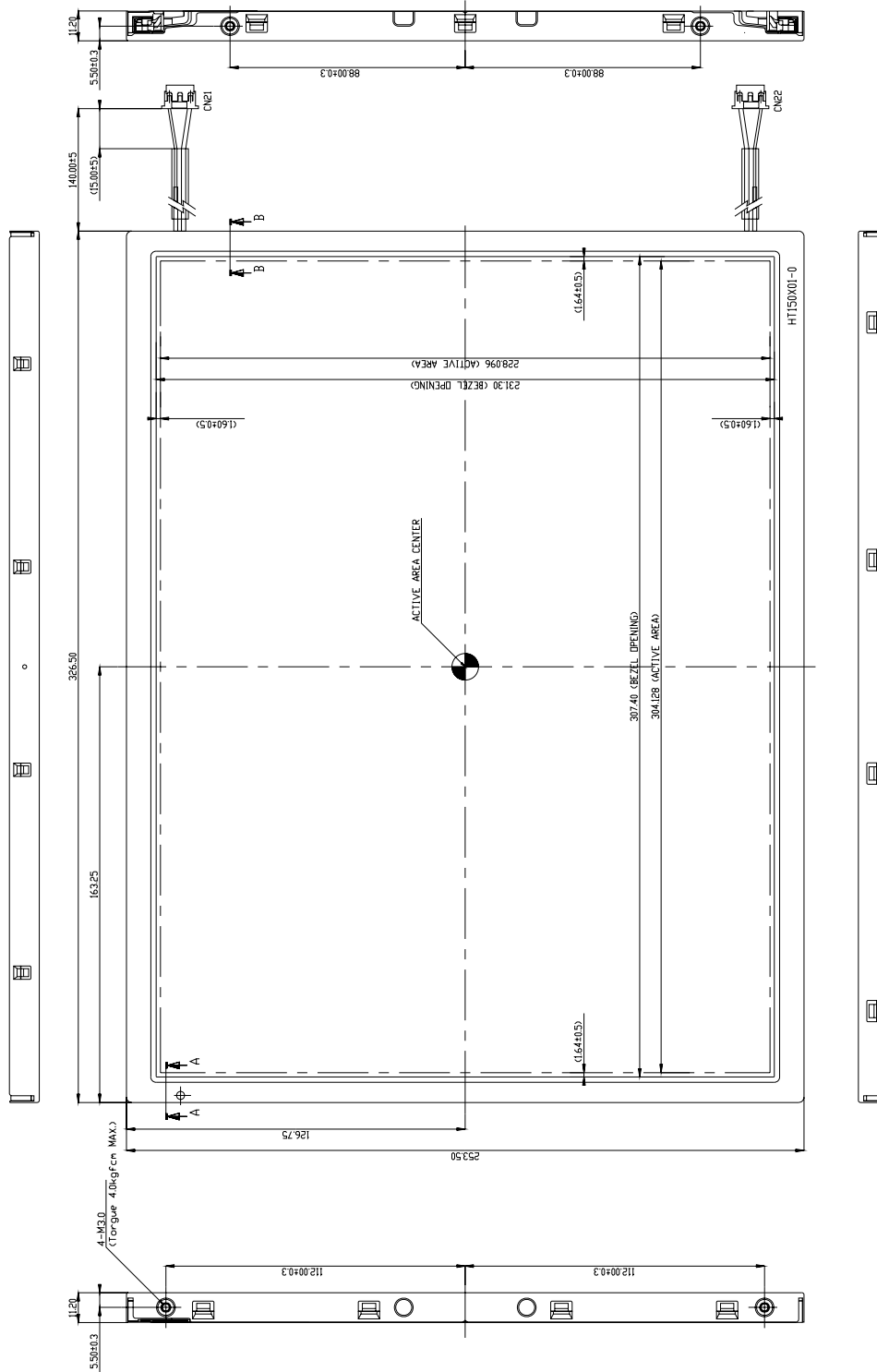

NOTE  
 1.(CN11=V, CONNECTOR) (H1R0SE\_DF14H-20P-1.25H(01))  
 2.(CN1,2=FL, CONNECTOR) (JST\_BHR-03VS-1)  
 3.OTHER SPECIFICATION: REFERS TO SPEC SHEET  
 4.GENERAL TOLERANCE: ±0.5

SPEC. NUMBER

SPEC. TITLE

PAGE

HT150X02-100 Preliminary Product Specification

27 OF 28

Figure 6. TFT-LCD Module Outline Dimensions (Rear view)

