

BCR12PM-14

MEDIUM POWER USE
INSULATED TYPE, PLANAR PASSIVATION TYPE

BCR12PM-14

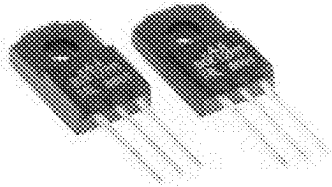

- ∧ IT (RMS) 12A
- ∧ VDRM 700V
- ∧ I_{FGT} ! , I_{RGT} ! , I_{RGT} # 30mA
- ∧ V_{iso} 1500V
- ∧ UL Recognized: File No. E80276

OUTLINE DRAWING

Dimensions
in mm

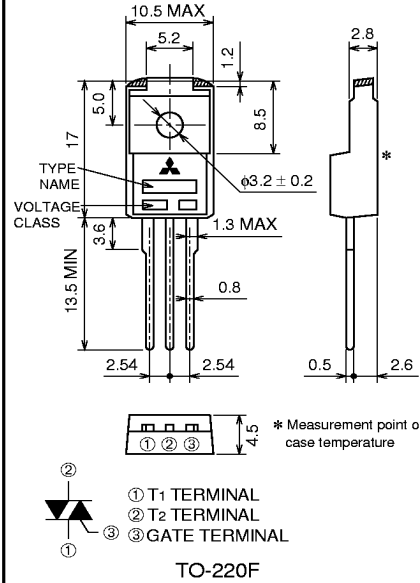

APPLICATION

Switching mode power supply, light dimmer, electric flasher unit, hair driver, control of household equipment such as TV sets · stereo · refrigerator · washing machine · infrared kotatsu · carpet, solenoid drivers, small motor control, copying machine, electric tool

MAXIMUM RATINGS

Symbol	Parameter	Voltage class		Unit
		14		
V _{DRM}	Repetitive peak off-state voltage *1	700		V
V _{DSM}	Non-repetitive peak off-state voltage *1	840		V

Symbol	Parameter	Conditions	Ratings	Unit
I _T (RMS)	RMS on-state current	Commercial frequency, sine full wave 360° conduction, T _c =74°C	12	A
I _{TSM}	Surge on-state current	60Hz sinewave 1 full cycle, peak value, non-repetitive	120	A
I _T ²	I _T ² for fusing	Value corresponding to 1 cycle of half wave 60Hz, surge on-state current	60	A ² s
P _{GM}	Peak gate power dissipation		5	W
P _G (AV)	Average gate power dissipation		0.5	W
V _{GM}	Peak gate voltage		10	V
I _{GM}	Peak gate current		2	A
T _j	Junction temperature		-40 ~ +125	°C
T _{stg}	Storage temperature		-40 ~ +125	°C
—	Weight	Typical value	2.0	g
V _{iso}	Isolation voltage	T _a =25°C, AC 1 minute, T ₁ · T ₂ · G terminal to case	1500	V

*1. Gate open.



BCR12PM-14

MEDIUM POWER USE
INSULATED TYPE, PLANAR PASSIVATION TYPE

ELECTRICAL CHARACTERISTICS

Symbol	Parameter	Test conditions	Limits			Unit	
			Min.	Typ.	Max.		
I _{DRM}	Repetitive peak off-state current	T _j =125°C, V _{DRM} applied	—	—	2.0	mA	
V _{TM}	On-state voltage	T _c =25°C, I _{TM} =20A, Instantaneous measurement	—	—	1.6	V	
V _{FGT} !	Gate trigger voltage *2	T _j =25°C, V _D =6V, R _L =6Ω, R _G =330Ω	!	—	—	1.5	V
V _{RGT} !			@	—	—	1.5	V
V _{RGT} #			#	—	—	1.5	V
I _{FGT} !	Gate trigger current *2	T _j =25°C, V _D =6V, R _L =6Ω, R _G =330Ω	!	—	—	30	mA
I _{RGT} !			@	—	—	30	mA
I _{RGT} #			#	—	—	30	mA
V _{GD}	Gate non-trigger voltage	T _j =125°C, V _D =1/2V _{DRM}	0.2	—	—	V	
R _{th(j-c)}	Thermal resistance	Junction to case *4	—	—	3.5	°C/W	
(dv/dt) _c	Critical-rate of rise of off-state commutating voltage		*3	—	—	V/μs	

*2. Measurement using the gate trigger characteristics measurement circuit.
 *3. The critical-rate of rise of the off-state commutating voltage is shown in the table below.
 *4. The contact thermal resistance R_{th(c-i)} in case of greasing is 0.5°C/W.

Voltage class	V _{DRM} (V)	(dv/dt) _c			Test conditions	Commutating voltage and current waveforms (inductive load)
		Symbol	Min.	Unit		
14	700	R	—	V/μs	1. Junction temperature T _j =125°C 2. Rate of decay of on-state commutating current (di/dt) _c =-6.0A/ms 3. Peak off-state voltage V _D =400V	
		L	10			

PERFORMANCE CURVES

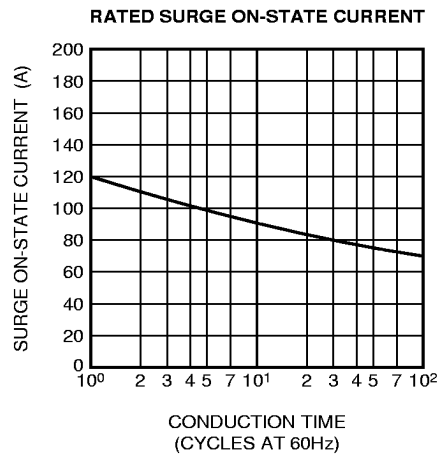
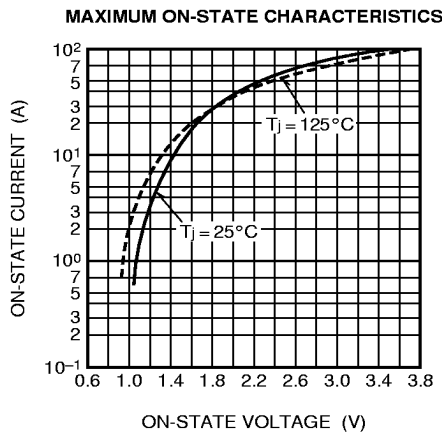

Feb.1999



BCR12PM-14

MEDIUM POWER USE
INSULATED TYPE, PLANAR PASSIVATION TYPE

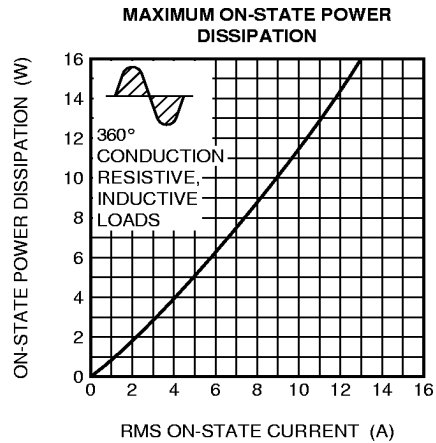
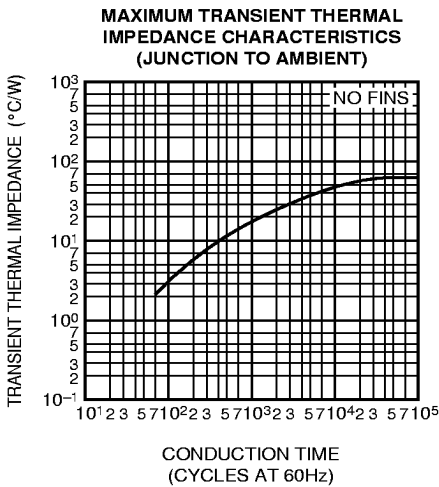
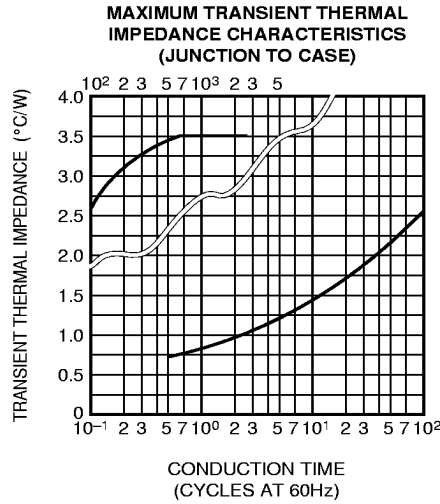
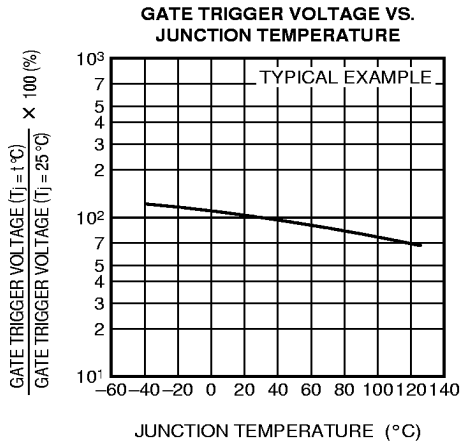
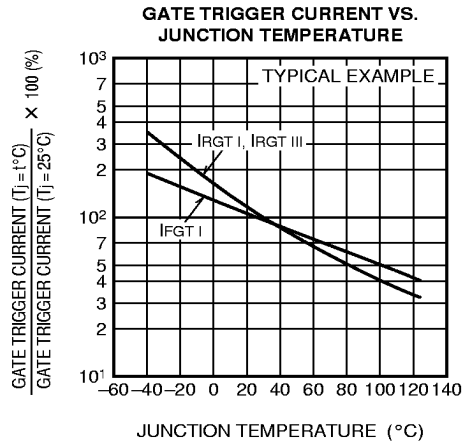
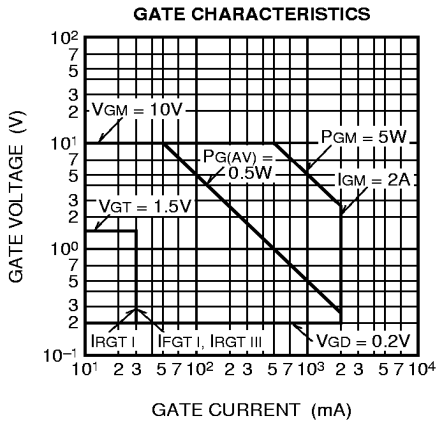

BCR12PM-14

MEDIUM POWER USE
INSULATED TYPE, PLANAR PASSIVATION TYPE

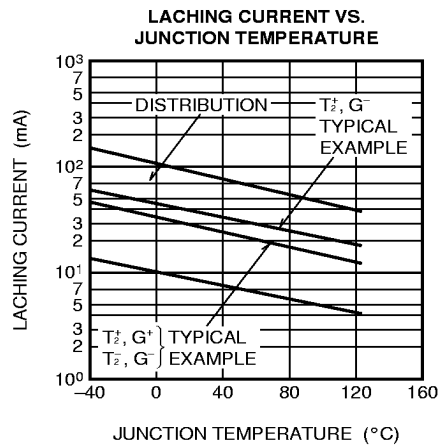
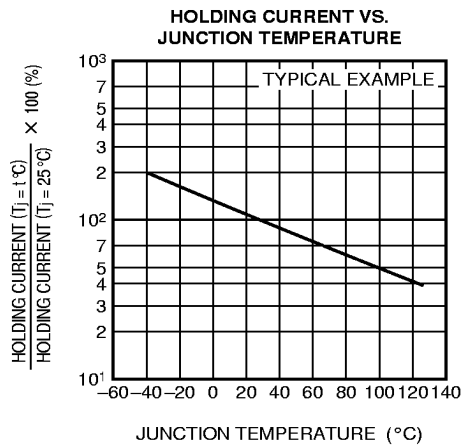
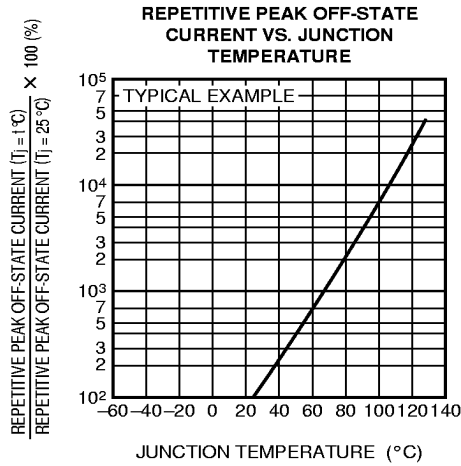
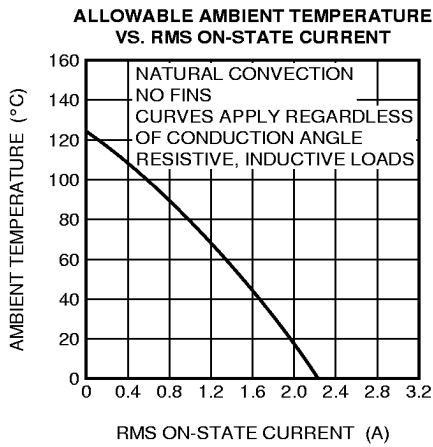
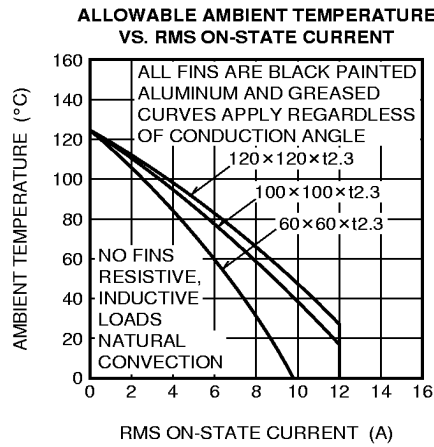
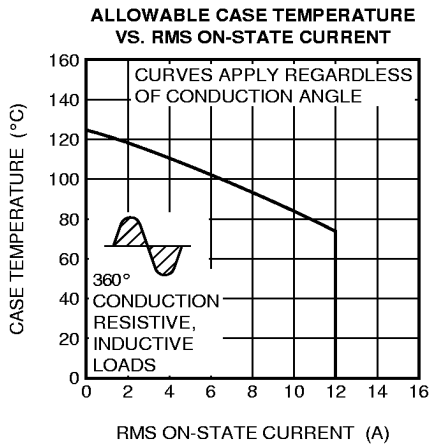

BCR12PM-14

MEDIUM POWER USE
INSULATED TYPE, PLANAR PASSIVATION TYPE

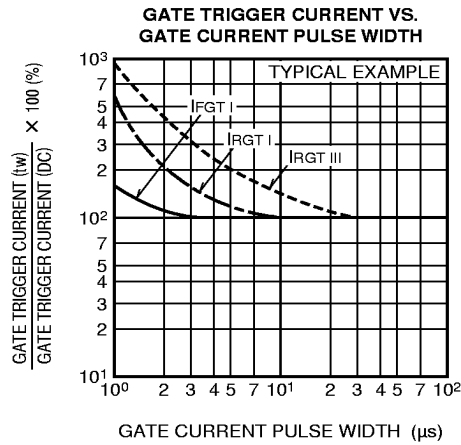
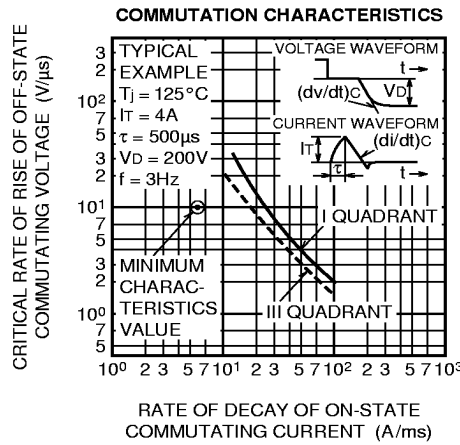
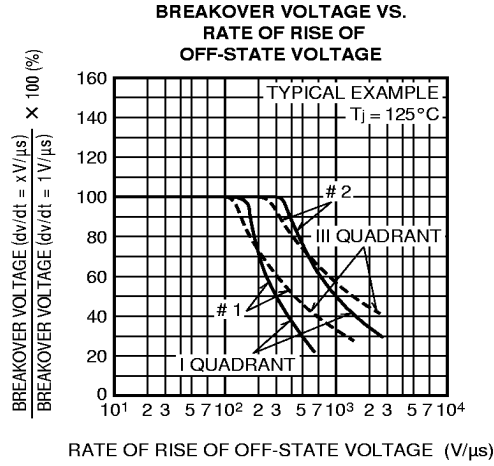
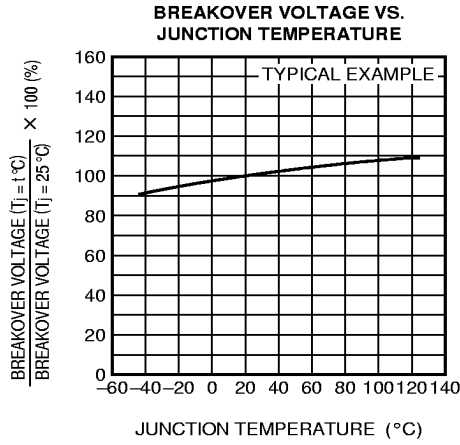

GATE TRIGGER CHARACTERISTICS TEST CIRCUITS

