

TOSHIBA Bi-CMOS INTEGRATED CIRCUIT SILICON MONOLITHIC

**TB62003P, TB62003F, TB62003FW, TB62004P, TB62004F, TB62004FW, TB62006P
TB62006F, TB62006FW, TB62007P, TB62007F, TB62007FW, TB62008P, TB62008F
TB62008FW, TB62009P, TB62009F, TB62009FW**

8CH DMOS TRANSISTOR ARRAY WITH GATE

TB62003P, TB62003F, TB62003FW
INVERTER & DMOS DRIVER

TB62004P, TB62004F, TB62004FW
THROUGH & DMOS DRIVER

TB62006P, TB62006F, TB62006FW
NAND & DMOS DRIVER

TB62007P, TB62007F, TB62007FW
AND & DMOS DRIVER

TB62008P, TB62008F, TB62008FW
NOR & DMOS DRIVER

TB62009P, TB62009F, TB62009FW
OR & DMOS DRIVER

The TB62003 Series are high-voltage, high-current arrays comprised of eight N-ch DMOS pairs.

FEATURES

- Package : Type-P DIP-20 pin
Type-F SOP-20 pin (200 mil)
Type-FW SOL-20 pin (300 mil)
- Output rating : 35 V (Min.) / 200 mA (Max.)
- Low power

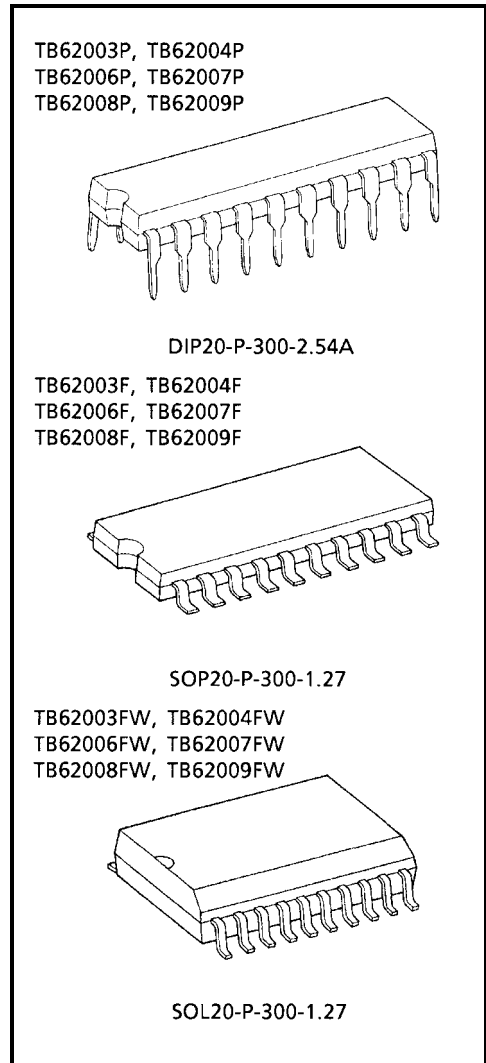

Weight

DIP20-P-300-2.54 A : 2.25 g (Typ.)
SOP20-P-300-1.27 : 0.25 g (Typ.)
SOL20-P-300-1.27 : 0.48 g (Typ.)

PIN CONNECTION (TOP VIEW)

TB62003P / F / FW

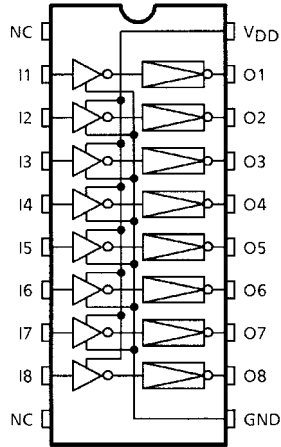

TB62004P / F / FW

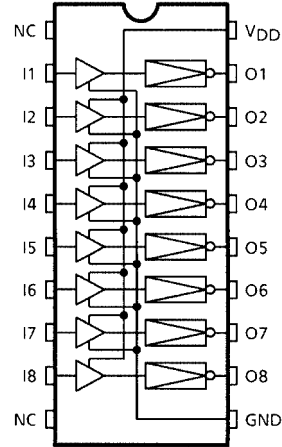

TB62003P / F / FW

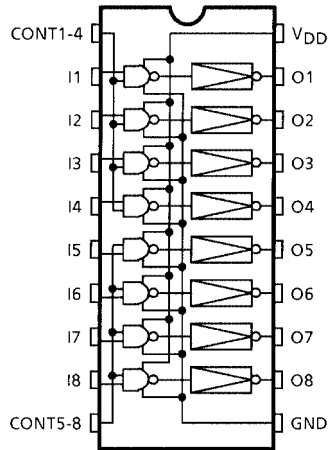

TB62007P / F / FW

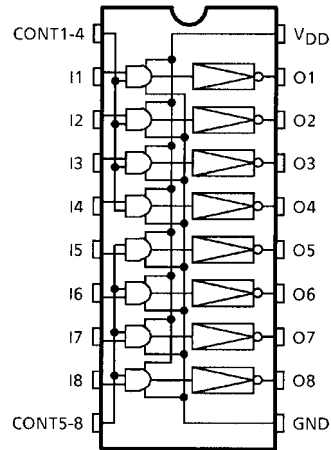

TB62008P / F / FW

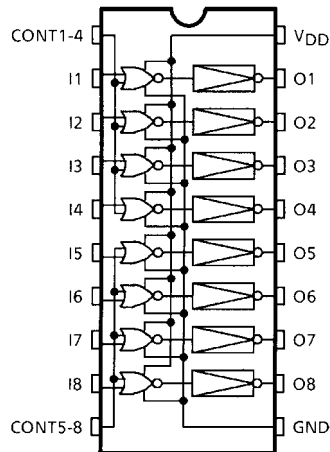

TB62009P / F / FW

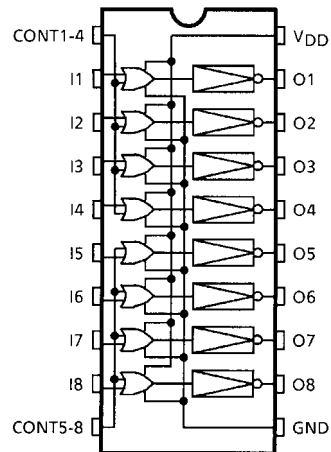

TRUTH TABLE

TB62006P / F / FW

INPUT				OUTPUT	
I1~4	I5~8	CONT1~4	CONT5~8	O3~4	O5~8
H	X	H	X	OFF	NOT FIX
H	X	L	X	ON	NOT FIX
L	X	H	X	ON	NOT FIX
L	X	L	X	ON	NOT FIX
X	H	X	H	NOT FIX	OFF
X	H	X	L	NOT FIX	ON
X	L	X	H	NOT FIX	ON
X	L	X	L	NOT FIX	ON

X: Don't Care

TB62007P / F / FW

INPUT				OUTPUT	
I1~4	I5~8	CONT1~4	CONT5~8	O3~4	O5~8
H	X	H	X	ON	NOT FIX
H	X	L	X	OFF	NOT FIX
L	X	H	X	OFF	NOT FIX
L	X	L	X	OFF	NOT FIX
X	H	X	H	NOT FIX	ON
X	H	X	L	NOT FIX	OFF
X	L	X	H	NOT FIX	OFF
X	L	X	L	NOT FIX	OFF

X: Don't Care

TB62008P / F / FW

INPUT				OUTPUT	
I1~4	I5~8	CONT1~4	CONT5~8	O3~4	O5~8
H	X	H	X	OFF	NOT FIX
H	X	L	X	OFF	NOT FIX
L	X	H	X	OFF	NOT FIX
L	X	L	X	ON	NOT FIX
X	H	X	H	NOT FIX	OFF
X	H	X	L	NOT FIX	OFF
X	L	X	H	NOT FIX	OFF
X	L	X	L	NOT FIX	ON

X: Don't Care

TB62009P / F / FW

INPUT				OUTPUT	
I1~4	I5~8	CONT1~4	CONT5~8	O3~4	O5~8
H	X	H	X	ON	NOT FIX
H	X	L	X	ON	NOT FIX
L	X	H	X	ON	NOT FIX
L	X	L	X	OFF	NOT FIX
X	H	X	H	NOT FIX	ON
X	H	X	L	NOT FIX	ON
X	L	X	H	NOT FIX	ON
X	L	X	L	NOT FIX	OFF

X: Don't Care

MAXIMUM RATINGS (Ta = 25°C)

CHARACTERISTIC		SYMBOL	RATING	UNIT
Supply Voltage		V _{DD}	7	V
DC Output Voltage		V _{DS}	-0.5~35	V
DC Output Current		I _{DS}	200	mA / ch
DC Input Voltage		V _{IN}	-0.4+V _{DD} +0.4	V
DC Input Current		I _{IN}	±5	mA
Input Diode Current		I _{ID}	±5	mA
Output Diode Current		I _{OK}	5	mA
Power Dissipation	P	P _D	1.47	W
	F		0.96 (Note 1)	
	FW		1.00 (Note 2)	
Operating Temperature		T _{opr}	-40~85	°C
Storage Temperature		T _{stg}	-55~150	°C

Note 1: On Glass Epoxy PCB (50 × 50 × 1.6 mm Cu 40%)

Note 2: Delated above 25°C in the proportion of 7.7 mW / °C (F Type), 8.0 mW / °C (FW Type).

RECOMMENDED OPERATING CONDITION (Ta = -40~85°C)

CHARACTERISTIC		SYMBOL	CONDITION		MIN	TYP.	MAX	UNIT
Supply Voltage Range		V _{DD}	—		4.5	—	5.5	V
DC Output Voltage		V _{DS}	—		—	—	30	V
DC Output Current	P	I _{DS}	Duty 80%	8ch On V _{DD} = 5.0 V	—	—	170	mA / ch
	F				—	—	90	
	FW				—	—	140	
	P		Duty 100%		—	—	150	
	F				—	—	80	
	FW				—	—	120	
DC Input Voltage		V _{IN}	—		GND	—	V _{DD}	V

ELECTRICAL CHARACTERISTICS (Ta = 25°C, VDD = 5.0 V)

CHARACTERISTIC	SYMBOL	TEST CIR-CUIT	TEST CONDITION	MIN	TYP.	MAX	UNIT
Output Leakage Current	I _{OZ}	—	V _{DS} = 35 V	—	—	50	μA
Low-Level Output Voltage	V _{DS}	—	I _{DS} = 150 mA	—	0.70	0.8	V
		—	I _{DS} = 200 mA	—	0.94	1.2	
Output Resistance	R _{ON}	—	I _{DS} = 200 mA	—	4.7	6.0	Ω
DC Input Current	I _{IN}	—	V _{IN} = GND, V _{IN} = V _{DD}	—	—	±1.0	μA
High-Level Input Voltage	V _{IN} (H)	—	—	3.5	—	V _{DD} +0.4	V
	V _{IN} (L)	—	—	-0.4	—	1.5	
Operating Supply Current	I _{DDopr}	—	8ch On, Output open f _{IN} = 1MHz	—	2	—	μA
Output Diode Forward Voltage	V _{FK}	—	I _{OK} = 5 mA	—	0.6	—	V
Turn-On Delay	t _{ON}	—	I _{OUT} = 170 mA	—	300	—	ns
Turn-Off Delay	t _{OFF}	—	—	—	300	—	
Supply Current	I _{DD}	—	—	—	—	10	μA
Input Capacitance	C _{IN}	—	—	—	15	—	pF

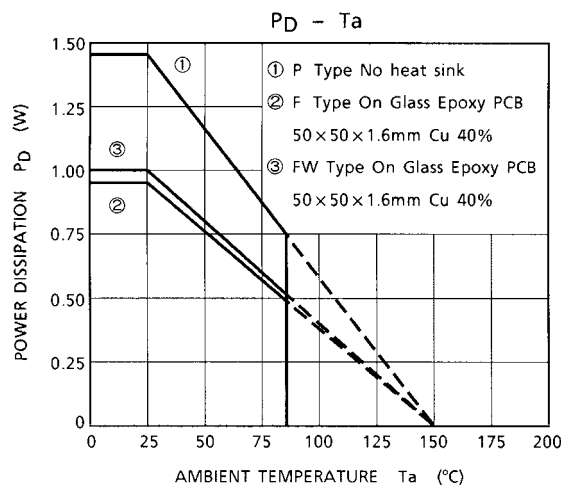

PRECAUTIONS for USING

This IC does not integrate protection circuits such as overcurrent and overvoltage protectors.

Thus, if excess current or voltage is applied to the IC, the IC may be damaged. Please design the IC so that excess current or voltage will not be applied to the IC.

Utmost care is necessary in the design of the output line, VCC (VDD) and GND line since IC may be destroyed due to short-circuit between outputs, air contamination fault, or fault by improper grounding.

PACKAGE DIMENSIONS

DIP20-P-300-2.54A

Unit: mm

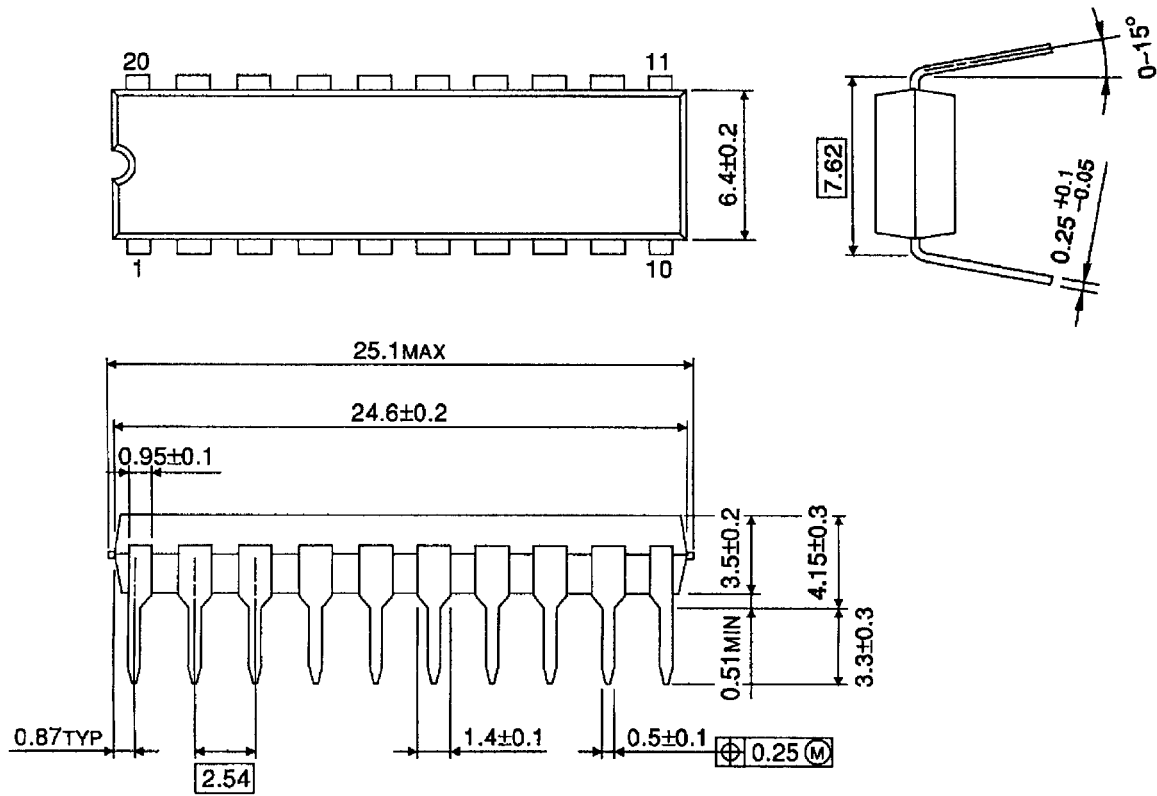

Weight: 2.25 g (Typ.)

PACKAGE DIMENSIONS

SOP20-P-300-1.27

Unit: mm

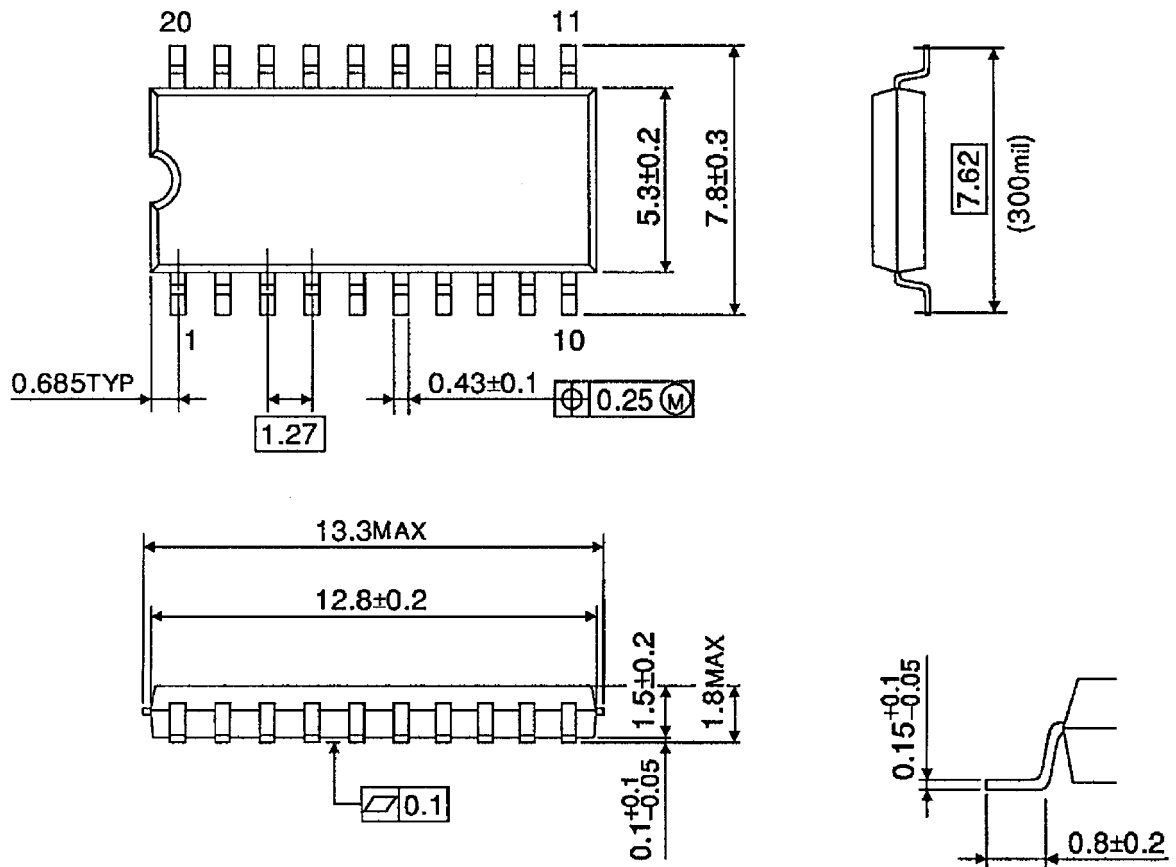

Weight: 0.25 g (Typ.)

PACKAGE DIMENSIONS

SOL20-P-300-1.27

Unit: mm

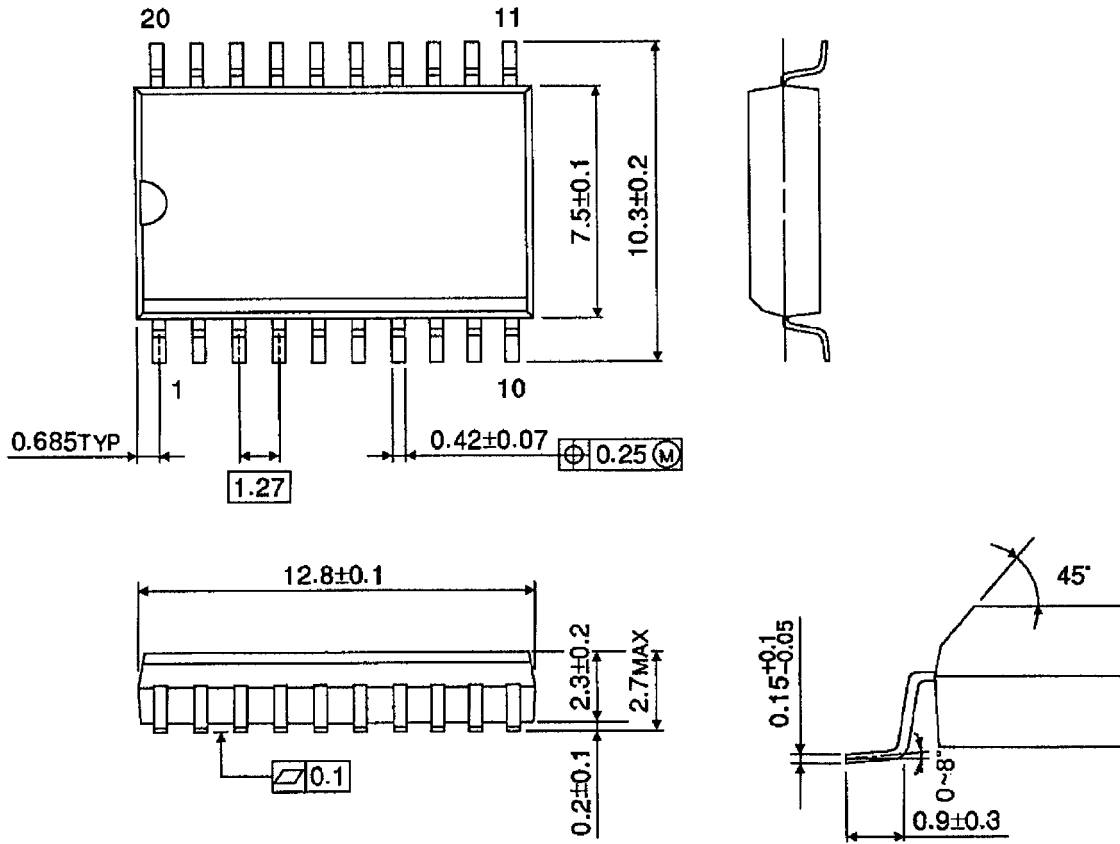

Weight: 0.48 g (Typ.)

RESTRICTIONS ON PRODUCT USE

000707EBA

- TOSHIBA is continually working to improve the quality and reliability of its products. Nevertheless, semiconductor devices in general can malfunction or fail due to their inherent electrical sensitivity and vulnerability to physical stress. It is the responsibility of the buyer, when utilizing TOSHIBA products, to comply with the standards of safety in making a safe design for the entire system, and to avoid situations in which a malfunction or failure of such TOSHIBA products could cause loss of human life, bodily injury or damage to property.
In developing your designs, please ensure that TOSHIBA products are used within specified operating ranges as set forth in the most recent TOSHIBA products specifications. Also, please keep in mind the precautions and conditions set forth in the "Handling Guide for Semiconductor Devices," or "TOSHIBA Semiconductor Reliability Handbook" etc..
- The TOSHIBA products listed in this document are intended for usage in general electronics applications (computer, personal equipment, office equipment, measuring equipment, industrial robotics, domestic appliances, etc.). These TOSHIBA products are neither intended nor warranted for usage in equipment that requires extraordinarily high quality and/or reliability or a malfunction or failure of which may cause loss of human life or bodily injury ("Unintended Usage"). Unintended Usage include atomic energy control instruments, airplane or spaceship instruments, transportation instruments, traffic signal instruments, combustion control instruments, medical instruments, all types of safety devices, etc.. Unintended Usage of TOSHIBA products listed in this document shall be made at the customer's own risk.
- The products described in this document are subject to the foreign exchange and foreign trade laws.
- The information contained herein is presented only as a guide for the applications of our products. No responsibility is assumed by TOSHIBA CORPORATION for any infringements of intellectual property or other rights of the third parties which may result from its use. No license is granted by implication or otherwise under any intellectual property or other rights of TOSHIBA CORPORATION or others.
- The information contained herein is subject to change without notice.