

## CMOS 4-BIT MICROCONTROLLER

**TMP47C221ADF, TMP47C421ADF**

The 47C221A/421A is a high speed and high performance 4-bit single chip microcomputer with LCD drive based on the TLC5-47 CMOS series with LCD driver.

| PART No.     | ROM          | RAM         | PACKAGE            | OTP          |
|--------------|--------------|-------------|--------------------|--------------|
| TMP47C221ADF | 2048 × 8-bit | 192 × 4-bit | QFP64-P-1420-1.00A | TMP47P421ADF |
| TMP47C421ADF | 4096 × 8-bit | 256 × 4-bit |                    |              |

**FEATURES**

- ◆ 4-bit single chip microcomputer
- ◆ Instruction execution time : 1.9  $\mu$ s (at 4.2 MHz)
- ◆ 89 basic instructions
  - Table look-up instructions
- ◆ Subroutine nesting : 15 levels max.
- ◆ 6 interrupt sources (External : 2, Internal : 4)
  - All sources have independent latches each, and multiple interrupt control is available.
- ◆ I/O port (28 pins)
  - Input     2 ports     5 pins
  - I/O       6 ports     23 pins
- ◆ Interval Timer
- ◆ Two 12-bit Timer / Counters
  - Timer, event counter, and pulse width measurement mode
- ◆ Serial Interface with 4-bit buffer
  - External / internal clock, and leading / trailing edge shift mode
- ◆ LCD driver
  - LCD direct drive is available (Max. 12-digit display at 1/4 duty LCD)
  - 1/4, 1/3, 1/2 duties or static drive are programmably selectable.
- ◆ Hold function
  - Battery / Capacitor back-up
- ◆ Real Time Emulator : BM4721A + BM4723A

QFP64-P1420-1.00A

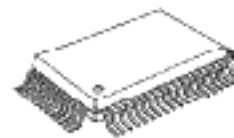

TMP47C221ADF  
 TMP47C421ADF  
 TMP47P421ADF

PIN ASSIGNMENT (TOP VIEW)

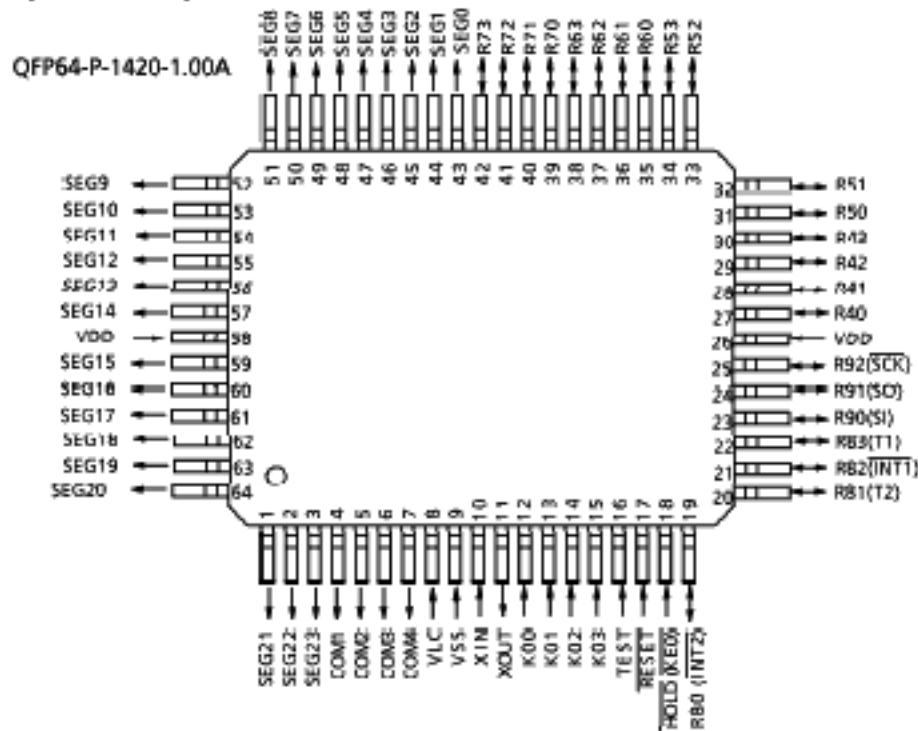

BLOCK DIAGRAM

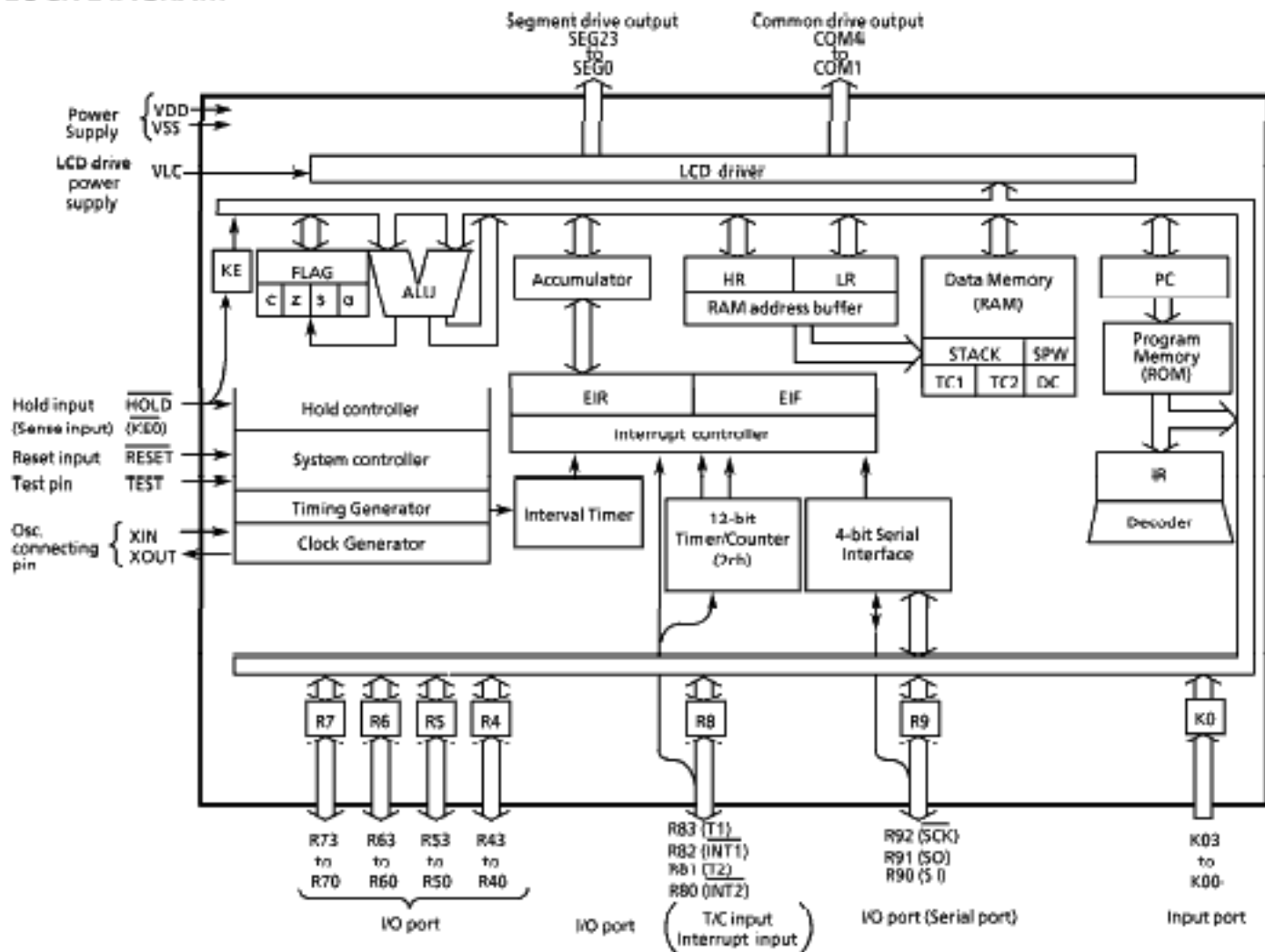

## PIN FUNCTION

| PIN NAME   | Input/Output  | FUNCTIONS   |                                  |
|--|---------------|---|----------------------------------|
| K03 to K00   | Input         | 4-bit input port  |                                  |
| R43 to R40   | I/O           | 4-bit I/O port with latch.  |                                  |
| R53 to R50   |               | When using as input port, the latch must be set to "1".                             |                                  |
| R63 to R60   |               | Every bit data is possible to be set, cleared and tested by the manipulation of the |                                  |
| R73 to R70   |               | L-register indirect addressing.   |                                  |
| R83 (T1)   | I/O (Input)   | 4-bit I/O port with latch.  | Timer / Counter 1 external input |
| R82 ( $\overline{\text{INT1}}$ )                     |               | When used as input port, external interrupt   | External interrupt 1 input       |
| R81 (T2)   |               | input pin, or Timer/Counter external input pin,                                     | Timer / Counter 2 external input |
| R80 ( $\overline{\text{INT2}}$ )                     |               | the latch must be set to "1".   | External interrupt 2 input       |
| R92 (SCK)  | I/O (I/O)     | 3-bit I/O port with latch.  | Serial clock I/O                 |
| R91 (SO)   | I/O (Output)  |   | Serial data output               |
| R90 (SI)   | I/O (Input)   |   | Serial data input                |
| SEG23 to SEG0  | Output        | LCD Segment drive output  |                                  |
| COM4 to COM1   |               | LCD Common drive output   |                                  |
| XIN  | Input         | Resonator connecting pin.   |                                  |
| XOUT   | Output        | For inputting external clock, XIN is used and XOUT is opened.                       |                                  |
| $\overline{\text{RESET}}$                            | Input         | Reset signal input  |                                  |
| $\overline{\text{HOLD}}$ ( $\overline{\text{KE0}}$ ) | Input (Input) | Hold request / release signal input   | Sense input                      |
| TEST   | Input         | Test pin for out-going test. Be opened or fixed to low level.                       |                                  |
| VDD  | Power supply  | + 5 V   |                                  |
| VSS  |               | 0 V (GND)   |                                  |
| VLC  |               | LCD drive power supply  |                                  |

## OPERATIONAL DESCRIPTION

Concerning the 47C221A/421A, the configuration and functions of hardwares are described. As the description has been provided with priority on those parts differing from the 47C200B/400B, the technical data sheets for the 47C200B/400B shall also be referred to.

### 1. SYSTEM CONFIGURATION

#### ◆ INTERNAL CPU FUNCTION

2.1 Program Memory (ROM)

2.2 Data Memory (ROM)

The others are the same as those of the 47C200B/400B.

#### ◆ PERIPHERAL HARDWARE FUNCTION

- ① I/O Ports
- ② Interval Timer
- ③ Timer / Counters (TC1, TC2)
- ④ LCD Driver
- ⑤ Serial Interface

The description has been provided with priority on functions (①, ③ and ④) added to and changed from the 47C200B/400B and ROM / RAM configurations.

### 2. INTERNAL CPU FUNCTION

#### 2.1 Program Memory (ROM)

Program memory of the 47C221A/421A are similar to the 47C200B/400B except that data conversion table cannot be used.

#### 2.2 Data Memory (RAM)

Data memory contained in the 47C221A has a  $192 \times 4$ -bit (addresses 00 to 7F<sub>H</sub>, C0 to FF<sub>H</sub>) capacity, and that contained in the 47C421A has a  $256 \times 4$ -bit (addresses 00-FF<sub>H</sub>) capacity.

There is no physical RAM in address 80-BF<sub>H</sub> in the 47C221A.

Therefore, when addresses 80-BF<sub>H</sub> are accessed on a program, RAM equivalent to address C0-FF<sub>H</sub> is accessed.

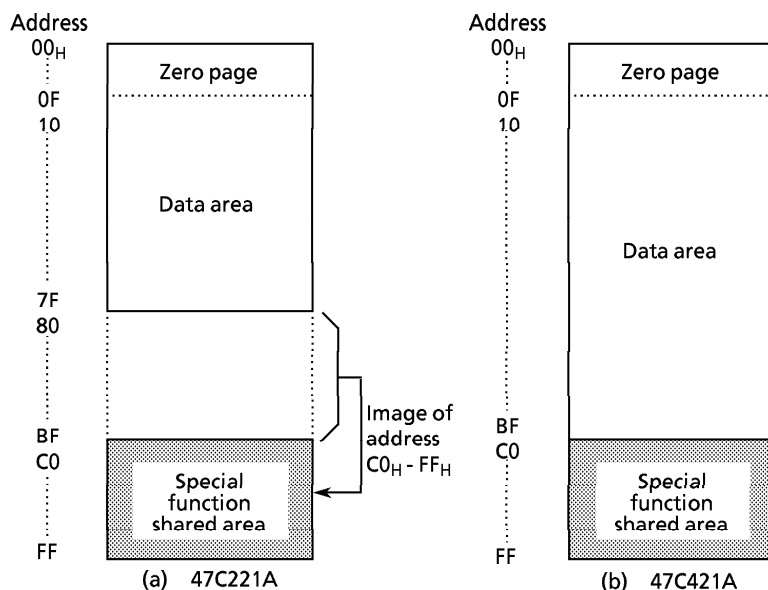

Figure 2-1. Data Memory Capacity and Address Assignment

### 3. PERIPHERAL HARDWARE FUNCTION

#### 3.1 I/O port

The 47C221A/421A have 8 I/O ports (28 pins) each as follows.

- ① K0 ; 4-bit input
- ② R4, R5, R6, R7 ; 4-bit input/output
- ③ R8 ; 4-bit input/output (shared by external interrupt input and Timer / Counter input)
- ④ R9 ; 3-bit input / output (shared by serial port)
- ⑤ KE ; 1-bit sense input (shared by hold request/release signal input)

For the 47C221A/421A, P1 and P2 ports are eliminated.

The operations and functions of other ports are similar to that of the 47C200B/400B.

Table 3-1 lists the port address assignments and the I/O instruction that can access the port. Further, the [OUTB @ HL] instruction and 5-bit to 8-bit data conversion table cannot be used.

Table 3-1. Port Address Assignments and Available I/O Instructions.

| Port address (**) | Port                  |                               | Input/Output instruction |                         |            |          |                        |                           |                             |   |   |   |   |   |   |   |   |   |   |
|-------------------|-----------------------|-------------------------------|--------------------------|-------------------------|------------|----------|------------------------|---------------------------|-----------------------------|---|---|---|---|---|---|---|---|---|---|
|                   | Input (IP**)          | Output (OP**)                 | IN %p, A<br>IN %p, @HL   | OUT A, %p<br>OUT@HL, %p | OUT #k, %p | OUTB @HL | SET %p, b<br>CLR %p, b | TEST %p, b<br>TESTP %p, b | SET @L<br>CLR @L<br>TEST @L |   |   |   |   |   |   |   |   |   |   |
| 00 <sub>H</sub>   | K0 input port         | —                             | ○                        | —                       | —          | —        | —                      | ○                         | —                           | — | — | — | — | — | — | — | — | — | — |
| 01                | —                     | —                             | —                        | —                       | —          | —        | —                      | —                         | —                           | — | — | — | — | — | — | — | — | — | — |
| 02                | —                     | —                             | —                        | —                       | —          | —        | —                      | —                         | —                           | — | — | — | — | — | — | — | — | — | — |
| 03                | —                     | —                             | —                        | —                       | —          | —        | —                      | —                         | —                           | — | — | — | — | — | — | — | — | — | — |
| 04                | R4 input port         | R4 output port                | ○                        | ○                       | ○          | —        | —                      | ○                         | —                           | — | — | — | — | — | — | — | — | — | ○ |
| 05                | R5 input port         | R5 output port                | ○                        | ○                       | ○          | —        | —                      | ○                         | —                           | — | — | — | — | — | — | — | — | — | ○ |
| 06                | R6 input port         | R6 output port                | ○                        | ○                       | ○          | —        | —                      | ○                         | —                           | — | — | — | — | — | — | — | — | — | ○ |
| 07                | R7 input port         | R7 output port                | ○                        | ○                       | ○          | —        | —                      | ○                         | —                           | — | — | — | — | — | — | — | — | — | ○ |
| 08                | R8 input port         | R8 output port                | ○                        | ○                       | ○          | —        | —                      | ○                         | —                           | — | — | — | — | — | — | — | — | — | ○ |
| 09                | R9 input port         | R9 output port                | ○                        | ○                       | ○          | —        | —                      | ○                         | —                           | — | — | — | — | — | — | — | — | — | ○ |
| 0A                | —                     | —                             | —                        | —                       | —          | —        | —                      | —                         | —                           | — | — | — | — | — | — | — | — | — | — |
| 0B                | —                     | —                             | —                        | —                       | —          | —        | —                      | —                         | —                           | — | — | — | — | — | — | — | — | — | — |
| 0C                | —                     | —                             | —                        | —                       | —          | —        | —                      | —                         | —                           | — | — | — | — | — | — | — | — | — | — |
| 0D                | —                     | —                             | —                        | —                       | —          | —        | —                      | —                         | —                           | — | — | — | — | — | — | — | — | — | — |
| 0E                | SIO, HOLD status      | —                             | ○                        | —                       | —          | —        | —                      | —                         | —                           | — | — | — | — | — | — | — | — | — | — |
| 0F                | Serial receive buffer | Serial transmit buffer        | ○                        | ○                       | ○          | —        | —                      | ○                         | —                           | — | — | — | — | — | — | — | — | — | — |
| 10 <sub>H</sub>   | Undefined             | Serial operating mode control | —                        | ○                       | —          | —        | —                      | —                         | —                           | — | — | — | — | — | — | — | — | — | — |
| 11                | Undefined             | —                             | —                        | —                       | —          | —        | —                      | —                         | —                           | — | — | — | — | — | — | — | — | — | — |
| 12                | Undefined             | —                             | —                        | —                       | —          | —        | —                      | —                         | —                           | — | — | — | — | — | — | — | — | — | — |
| 13                | Undefined             | —                             | —                        | —                       | —          | —        | —                      | —                         | —                           | — | — | — | — | — | — | — | — | — | — |
| 14                | Undefined             | —                             | —                        | —                       | —          | —        | —                      | —                         | —                           | — | — | — | — | — | — | — | — | — | — |
| 15                | Undefined             | —                             | —                        | —                       | —          | —        | —                      | —                         | —                           | — | — | — | — | — | — | — | — | — | — |
| 16                | Undefined             | —                             | —                        | —                       | —          | —        | —                      | —                         | —                           | — | — | — | — | — | — | — | — | — | — |
| 17                | Undefined             | —                             | —                        | —                       | —          | —        | —                      | —                         | —                           | — | — | — | — | — | — | — | — | — | — |
| 18                | Undefined             | —                             | —                        | —                       | —          | —        | —                      | —                         | —                           | — | — | — | — | — | — | — | — | — | — |
| 19                | Undefined             | Interval timer control        | —                        | ○                       | —          | —        | —                      | —                         | —                           | — | — | — | — | — | — | — | — | — | — |
| 1A                | Undefined             | LCD driver control 1          | —                        | ○                       | —          | —        | —                      | —                         | —                           | — | — | — | — | — | — | — | — | — | — |
| 1B                | Undefined             | LCD driver control 2          | —                        | ○                       | —          | —        | —                      | —                         | —                           | — | — | — | — | — | — | — | — | — | — |
| 1C                | Undefined             | Timer/Counter 1 control       | —                        | ○                       | —          | —        | —                      | —                         | —                           | — | — | — | — | — | — | — | — | — | — |
| 1D                | Undefined             | Timer/Counter 2 control       | —                        | ○                       | —          | —        | —                      | —                         | —                           | — | — | — | — | — | — | — | — | — | — |
| 1E                | Undefined             | —                             | —                        | —                       | —          | —        | —                      | —                         | —                           | — | — | — | — | — | — | — | — | — | — |
| 1F                | Undefined             | Serial interface control      | —                        | ○                       | —          | —        | —                      | —                         | —                           | — | — | — | — | — | — | — | — | — | — |

Note. " — " means the reserved state. Unavailable for the user programs.

### 3.2 Timer/Counter (TC1, TC2)

The timer/counter of 47C221A/421A are similar to that of the 47C200B/400B except for the following point. The maximum frequency applied to the external input pin under the event counter mode is dependent upon the operating state of the LCD drive circuit.

Table 3-2. The maximum frequency applied to the external input pin under the event counter mode.

| Operating state of the LCD driver | Maximum frequency applied [Hz] |     |                     |       |
|-----------------------------------|--------------------------------|-----|---------------------|-------|
|                                   | 1-channel operation            |     | 2-channel operation |       |
|                                   | TC1                            | TC2 | TC1                 | TC2   |
| At time of blanking operation     | fc/32                          |     | fc/32               | fc/40 |
| When LCD display is enabled       | fc/64                          |     | fc/72               |       |

Note. *fc* ; Basic clock frequency

### 3.3 LCD Driver

The 47C221A/421A have the circuit that directly drives the liquid crystal display (LCD) and its control circuit.

The 42C221/421A have the following connecting pins with LCD.

- ① Segment output pins 24 pins (SEG23-SEG0)
- ② Common output pins 4 pins (COM4-COM1)

In addition, VLC pin is provided as the driver power.

The devices that can be directly driven is selectable from LCD of following drive methods.

- ① 1/4 duty (1/3 bias) LCD ..... Max. 96 segments (8 segments × 12 digits)
- ② 1/3 duty (1/3 bias) LCD ..... Max. 72 segments (8 segments × 9 digits)
- ③ 1/2 duty (1/2 bias) LCD ..... Max. 48 segments (8 segments × 6 digits)
- ④ Static LCD ..... Max. 24 segments (8 segments × 3 digits)

#### 3.3.1 Configuration of LCD driver

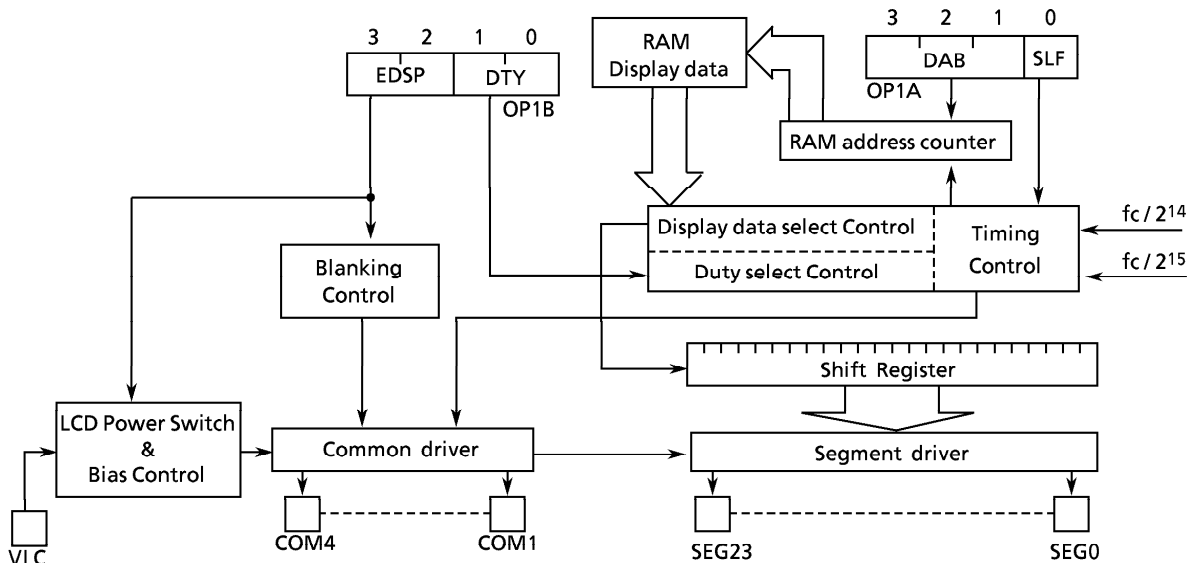

Figure 3-1. Configuration of LCD driver

### 3.3.2 Control of LCD driver

The LCD driver is controlled by the command register 1, 2 (OP1A, OP1B).

Note that, the MSB of the command register 2 must be cleared to "0" (set to blanking or designation of driving method) during accessing the command register 1.

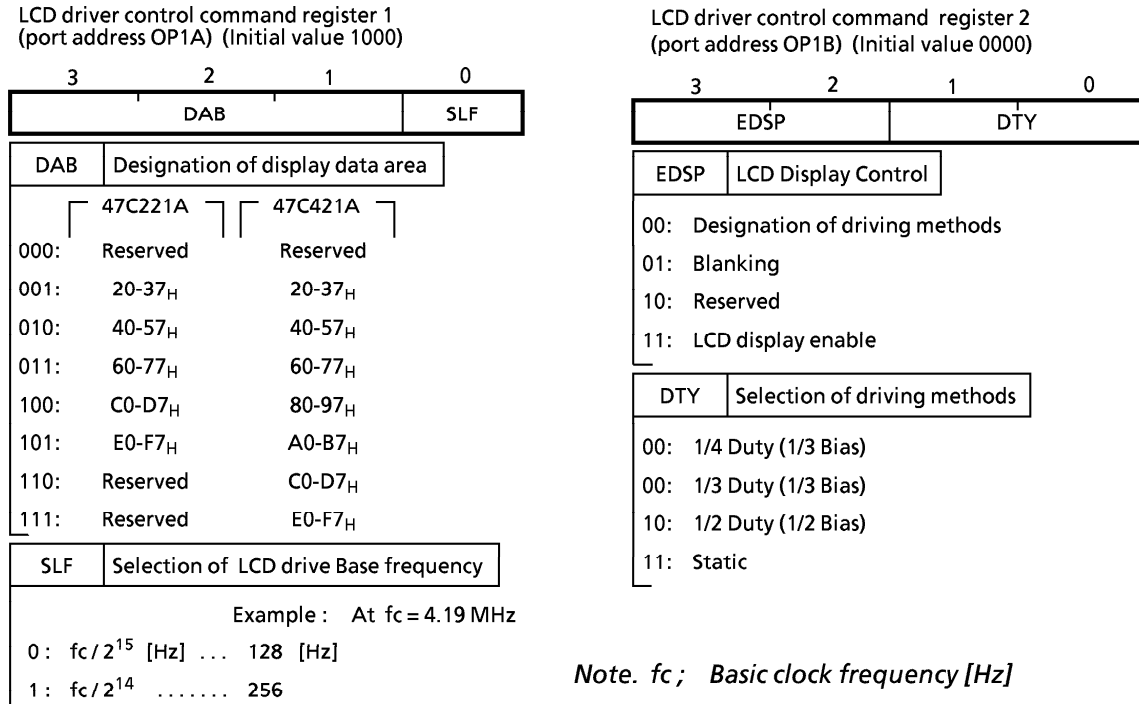
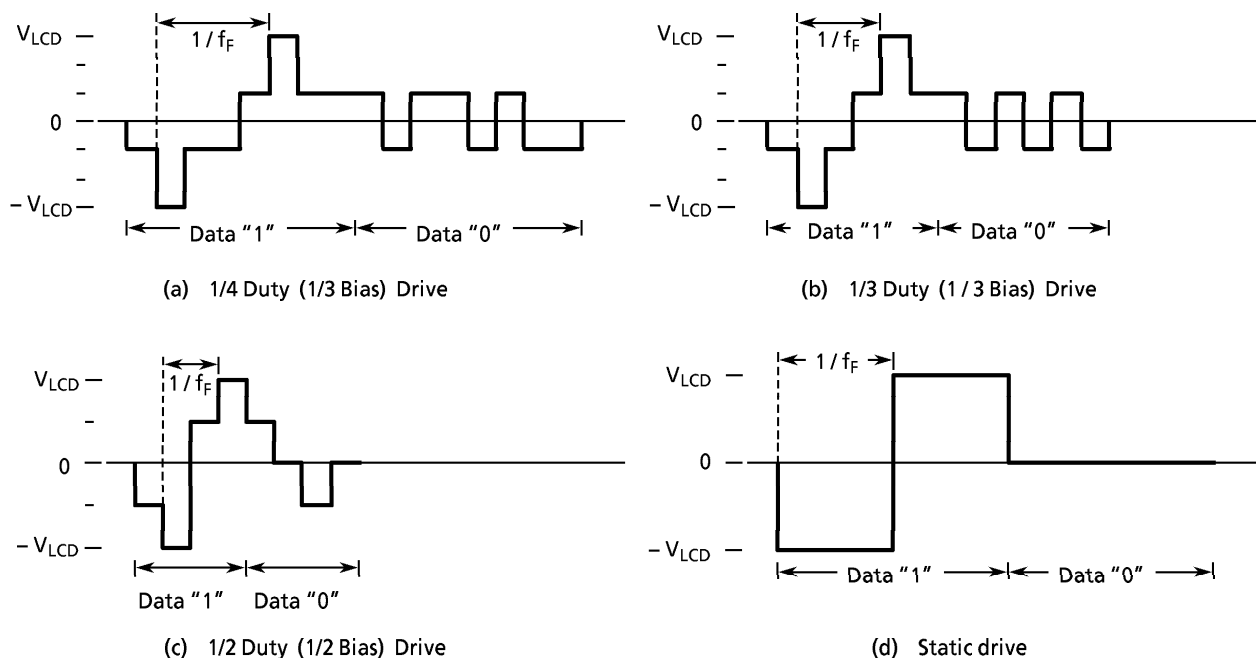

Figure 3-2. LCD driver control command register



(1) Driving methods of LCD driver

4 kinds of driving methods can be selected by DTY (bits 1 and 0 of command register). Figure 3-3 shows driving waveforms for LCD.



Note.  $f_F$ ; LCD Frame frequency  $V_{LCD}$ ; LCD drive voltage ( $= V_{DD} - V_{LC}$ )

Figure 3-3. LCD drive waveform (Voltage COM-SEG Pins)

(2) Frame frequency

Frame frequency is set according to the drive method and base frequency as shown in the following table 3-3.

It is possible to select base frequency (either one of 2 kind frequencies obtained from the driver) by SLF (bit 0 of command register 1).

Table 3-3. Setting of LCD frame frequency

| Driving methods<br>Base frequency | Frame Frequency [Hz] |  |  |                      |
|-----------------------------------|----------------------|--|--|----------------------|
|                                   | 1/4 Duty             | 1/3 Duty                               | 1/2 Duty                               | Static               |
| $\frac{f_c}{2^{15}}$              | $\frac{f_c}{2^{15}}$ | $\frac{4}{3} \cdot \frac{f_c}{2^{15}}$ | $\frac{4}{2} \cdot \frac{f_c}{2^{15}}$ | $\frac{f_c}{2^{15}}$ |
| Ex. at $f_c = 4.19 \text{ MHz}$   | 128                  | 171                                    | 256                                    | 128                  |
| $\frac{f_c}{2^{14}}$              | $\frac{f_c}{2^{14}}$ | $\frac{4}{3} \cdot \frac{f_c}{2^{14}}$ | $\frac{4}{2} \cdot \frac{f_c}{2^{14}}$ | $\frac{f_c}{2^{14}}$ |
| Ex. at $f_c = 2.10 \text{ MHz}$   | 128                  | 171                                    | 256                                    | 128                  |

Note.  $f_c$ ; Basic clock frequency [Hz]

(3) LCD drive voltage

The LCD drive voltage ( $V_{LCD}$ ) is given by the difference in potential ( $V_{DD} - VLC$ ) between pins VDD and VLC. Therefore, when the CPU operating voltage and LCD drive voltage are the same, the VLC pin is connected to the VSS pin.

The LCD light only when the difference in potential between the segment output and common output is  $\pm V_{LCD}$ , and turn off at all other times.

During reset, the power switch of the LCD driver is turned off automatically, shutting off the VLC voltage.

Both the segment output and common output become  $V_{DD}$  level at this time and the LCD turn off. The power switch is turned on to supply VLC voltage to the LCD driver by setting EDSP (bits 2 and 3 of the command register 2) to "11<sub>B</sub>". After that, the power switch will not turn off even during blanking (setting EDSP to "01<sub>B</sub>") and the VLC voltage continues to flow.

The power switch is turned off during hold operation low power consumption by turning off the LCD. When hold operation is released the status in effect immediately before the hold operation is reinstated.

3.3.3LCD display operation

(1) Display data setting

Display data are stored to the display data area (Max.24 words) in the data memory.

The display data area is set using DAB (bits 1 to 3 of command register 1). During reset, the display data area is set to addresses C0-D7<sub>H</sub> (47C221A) and 80-97<sub>H</sub> (47C421A).

The display data stored to the display data area are read automatically and sent to the LCD driver by the hardware.

The LCD driver generates the segment signals and common signals in accordance with the display data and drive methods. Therefore, display patterns can be changed by only overwriting the contents of the display data area with a program. The table look-up instruction is mainly used for this overwriting. Figure 3-4 shows the correspondence between the display data area and the SEG/COM pins. The LCD light when the display data is "1" and turn off when "0".

The number of segment which canbe driven differs depending on the LCD drive method, therefore, the number of display data area bits used to store the data also differs (Refer to Table 3-4). Consequently, data memory not used to store display data and data memory for which the addresses are not connected to LCD can be used to store ordinary user's processing data.

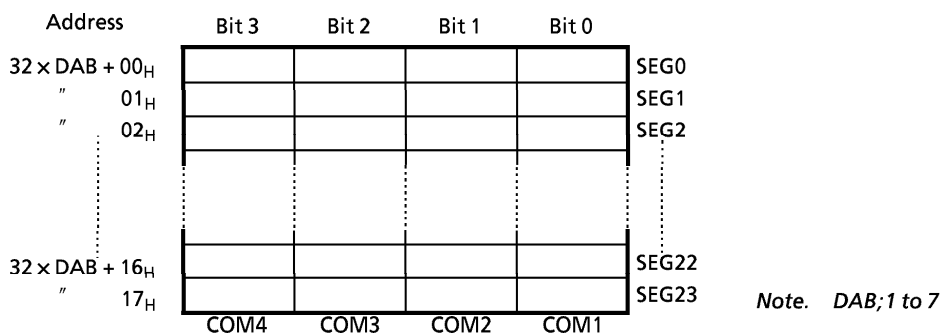

Figure 3-4. The correspondence between the display data area and the SEG/COM pins

Table 3-4. The data memory bits that are used for driving method and storing display data.

| drive methods | Bit 3 | Bit 2 | Bit 1 | Bit 0 |
|---------------|-------|-------|-------|-------|
| 1/4 Duty      | COM4  | COM3  | COM2  | COM1  |
| 1/3 Duty      | -     | COM3  | COM2  | COM1  |
| 1/2 Duty      | -     | -     | COM2  | COM1  |
| Static        | -     | -     | -     | COM1  |

Note. - ; The data memory bits that are not used for storing display data

(2) Transfer of display data

The display data stored to the display data area are automatically transferred to the LCD driver. The processing is performed in the following sequence.

- ① The LCD driver issues a display data send request to the CPU
- ② When the instruction (or Timer / Counter processing, interrupt receive processing) currently being executed is completed, the CPU reads out the data for one cycle and sends it to the LCD driver.

The data sending cycle is generated when the VLC voltage is being applied to the LCD driver. That is, after reset is canceled, it is not generated until EDSP is set to "11<sub>B</sub>". Table 3-5 shows the data sending cycle generation frequency.

When LCD display is enabled, the virtual instruction execution speed drops. For example, when SLF = 0 and using 1/4 duty drive, this would be 2.05 μs, for an instruction execution speed of 2 μs.

Table 3-5. Frequency of data sending cycle insertion

| SLF | Driving method      | Frequency of data sending cycle insertion |
|-----|---------------------|---|
| 0   | Static drive        | 24 times in 4,096 instruction cycles      |
|     | Except Static drive | 24 times in 1,024 instruction cycles      |
| 1   | Static drive        | 24 times in 2,048 instruction cycles      |
|     | Except Static drive | 24 times in 512 instruction cycles        |

(3) Blanking

Blanking is applied by setting EDSP to "01<sub>B</sub>" and turns off the LCD by outputting non light operation level to the COM pin.

The SEG pin continuously outputs the signal level in accordance with the display data and drive method. With static drive, no voltage is applied between the COM and SEG pins when the LCD is turned off by data (display data cleared to "0"), but the COM pin output becomes constant at the V<sub>LCD</sub>/2 level when turning off the LCD by blanking, so the COM and SEG pins are then driven by V<sub>LCD</sub>/2.

3.3.4 Control method of LCD driver

(1) Initial setting

Flow chart of initial setting is shown Figure 3-5.

Example: When operating the 47C421A with 1/4 duty LCD using a frame frequency of  $f_c/2^{15}$ [Hz] (display data area at addresses 80-97<sub>H</sub>).

```

LD      A, #0000B; Sets the 1/4 duty drive.
OUT     A, %OP1B
LD      A, #1000B; Setting of base frequency.
OUT     A, %OP1A ; Setting of display area in the
           memory.
:       Setting of clear or initial value of
:       display area in the memory.
LD      A, #1100B; Display enable (Release of
           blanking)
OUT     A, %OP1B
:
    
```

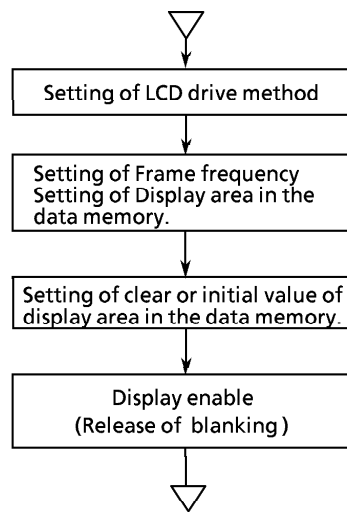

Figure 3-5. Initial setting of LCD driver

(2) Display data setting

Normally, display data are kept permanently in the program memory and are then stored to the display data area by the table look up instruction.

This can be explained using numerical display with 1/4 duty LCD as an example. The COM and SEG connections to the LCD are the same as those shown in Figure 3-6, and the display data are as shown in Table 3-6. Programming example for displaying numerals corresponding to BCD data stored at address 10<sub>H</sub> in the data memory is shown below. The display data area is at addresses 20<sub>H</sub> and 21<sub>H</sub>.

```

LD     HL, #0FCH           ;To set the DC
LD     A,  10H
ST     A,  @HL+
ST     #DTBL/16, @HL+
ST     #DTBL/256,@HL+
LD     HL, #20H           ;Display of data corresponding
LDL    A, @DC
ST     A, @HL+
LDH    A, @DC+
ST     A, @HL+
:
DTBL: DATA 11011111B, 00000110B,
            11100011B, 10100111B,
            00110110B, 10110101B,
            11110101B, 00010111B,
            11110111B, 10110111B
    
```

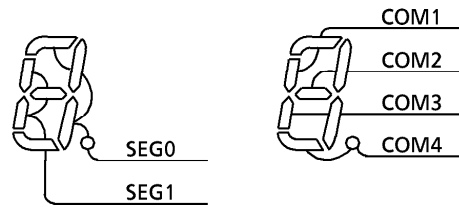

Figure 3-6. Example of COM and SEG connections

Table 3-6. Examples of Display Data (1/4 Duty LCD)

| Numeral | Display | Display data memory |       | Numeral | Display | Display data memory |       |
|---------|---------|---------------------|-------|---------|---------|---------------------|-------|
|         |         | Upper               | Lower |         |         | Upper               | Lower |
| 0       | 0.      | 1101                | 1111  | 5       | 5       | 1011                | 0101  |
| 1       | 1       | 0000                | 0110  | 6       | 6       | 1111                | 0101  |
| 2       | 2       | 1110                | 0011  | 7       | 7       | 0001                | 0111  |
| 3       | 3       | 1010                | 0111  | 8       | 8       | 1111                | 0111  |
| 4       | 4       | 0011                | 0110  | 9       | 9       | 1011                | 0111  |

Table 3-7 shows the same numerical display used in Table 3-6, but using 1/2 duty LCD. The connections of the COM and SEG pins to the LCD are the same as those shown in Figure 3-7. The display data area is at addresses 20-23H.

```

LD      HL, #0FCH      ; To set the DC
LD      A, 10H
ST      A, @HL+
ST      #DTBL/16, @HL+
ST      #DTBL/256, @HL+
LD      HL, #20H      ; Display of data corresponding
LDL     A, @DC
ST      A, @HL+
RORC   A
RORC   A
ST      A, @HL+
LDH     A, @DC+
ST      A, @HL+
RORC   A
RORC   A
ST      A, @HL+
:
DTBL:  DATA  01110111B, 00100010B,
              10010111B, 10100111B,
              11100010B, 11100101B,
              11110101B, 01100011B,
              11110111B, 11100111B
    
```



Figure 3-7. Example of COM and SEG connections

Table 3-7. Example of Display Data (1/2 duty LCD)

| Nu-meral | Display data memory |      |       |      | Nu-meral | Display data memory |      |       |      |
|----------|---------------------|------|-------|------|----------|---------------------|------|-------|------|
|          | Upper               |      | Lower |      |          | Upper               |      | Lower |      |
| 0        | **01                | **11 | **01  | **11 | 5        | **11                | **10 | **01  | **01 |
| 1        | **00                | **10 | **00  | **10 | 6        | **11                | **11 | **01  | **01 |
| 2        | **10                | **01 | **01  | **11 | 7        | **01                | **10 | **00  | **11 |
| 3        | **10                | **10 | **01  | **11 | 8        | **11                | **11 | **01  | **11 |
| 4        | **11                | **10 | **00  | **10 | 9        | **11                | **10 | **01  | **11 |

Note. \* ; don't care

(3) Example of drive output

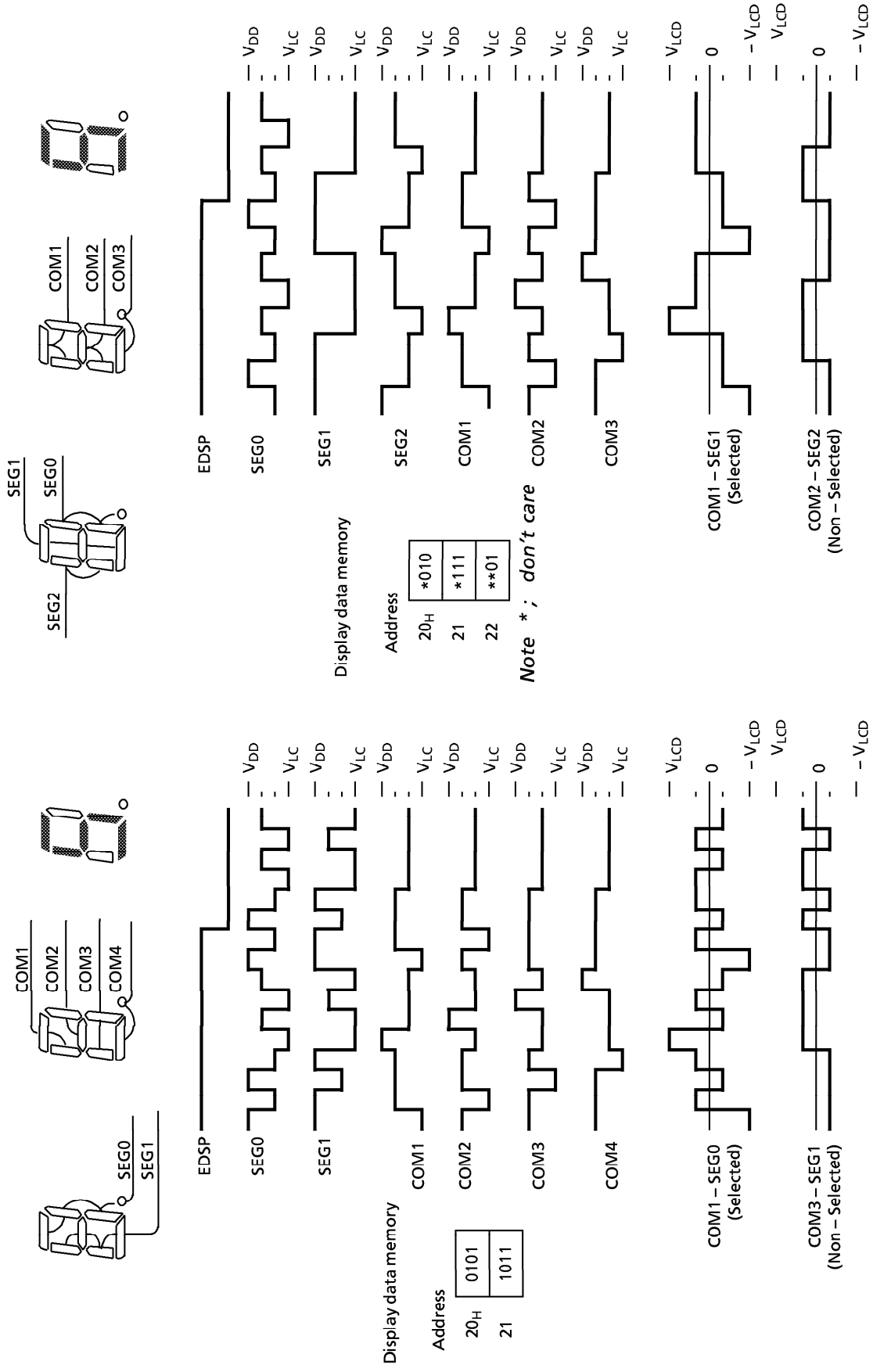

Figure 3-8. 1/4Duty (1/3Bias) Drive

Figure 3-9. 1/3Duty (1/3Bias) Drive

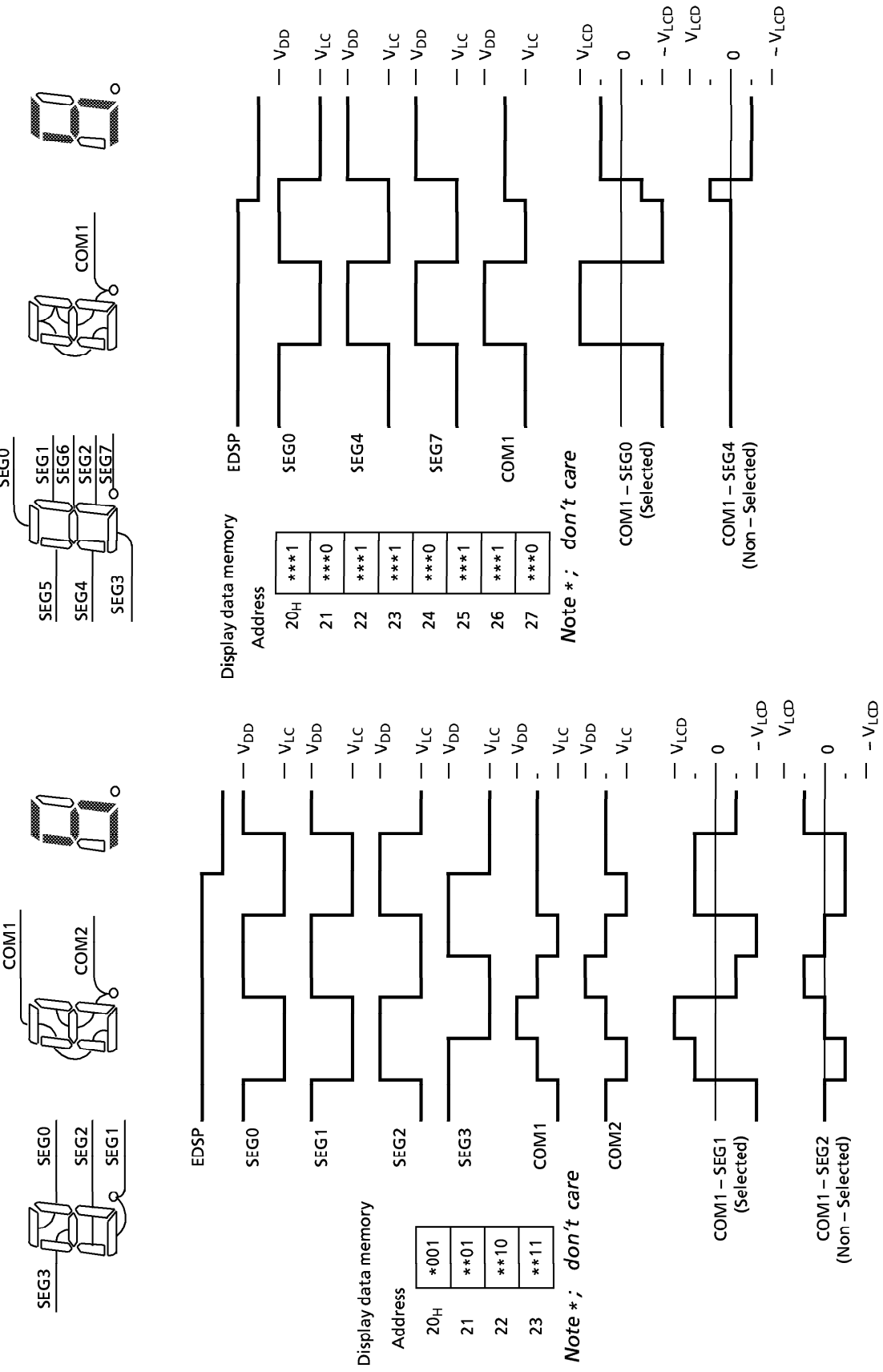

Figure 3-11. Static Drive

Figure 3-10. 1/2 Duty (1/2 Bias) Drive

**INPUT / OUTPUT CIRCUITRY**

(1) Control pins

Input / Output circuitries of the 47C221A/421A control pins are similar to that of the 47C200B/400B.

(2) I/O Ports

The input/output circuitries of the 47C221A/421A I/O ports are shown below, any one of the circuitries can be chosen by a code (GA-GF) as a mask option.

| PORT           | I/O   | INPUT/OUTPUT CIRCUITRY and CODE |        |                       | REMARKS   |
|----------------|-------|---------------------------------|--------|-----------------------|---|
|                |       | GA, GD                          | GB, GE | GC, GF                |   |
| K0             | Input |                                 |        |                       | pull-up/pull-down resistor<br><br>R <sub>IN</sub> = 70 kΩ (typ.)<br>R = 1 kΩ (typ.) |
| R4<br>R5<br>R6 | I/O   | <p>Initial "Hi-Z"</p>           |        | <p>Initial "High"</p> | Sink open drain or push-pull output<br><br>R = 1 kΩ (typ.)                          |
| R7             | I/O   |                                 |        |                       | Sink open drain output<br>Initial "Hi-Z"<br>R = 1 kΩ (typ.)                         |
| R8<br>R9       | I/O   |                                 |        |                       | Sink open drain output<br>Initial "Hi-Z"<br>Hysteresis input<br>R = 1 kΩ (typ.)     |



## ELECTRICAL CHARACTERISTICS

ABSOLUTE MAXIMUM RATINGS (V<sub>SS</sub> = 0 V)

| PARAMETER                                    | SYMBOL            | PINS                       | RATING                         | UNIT |
|--|-------------------|----------------------------|--------------------------------|------|
| Supply Voltage                               | V <sub>DD</sub>   |                            | - 0.5 to 7                     | V    |
| Supply Voltage (LCD drive)                   | V <sub>LC</sub>   |                            | - 0.5 to V <sub>DD</sub> + 0.5 | V    |
| Input Voltage                                | V <sub>IN</sub>   |                            | - 0.5 to V <sub>DD</sub> + 0.5 | V    |
| Output Voltage                               | V <sub>OUT1</sub> | Except sink open drain pin | - 0.5 to V <sub>DD</sub> + 0.5 | V    |
|  | V <sub>OUT2</sub> | Sink open drain pin        | - 0.5 to 10                    |      |
| Output Current (per 1 pin)                   | I <sub>OUT</sub>  |                            | 3.2                            | mA   |
| Power Dissipation [T <sub>opr</sub> = 70 °C] | PD                |                            | 400                            | mW   |
| Soldering Temperature (time)                 | T <sub>slid</sub> |                            | 260 (10 s)                     | °C   |
| Storage Temperature                          | T <sub>stg</sub>  |                            | - 55 to 125                    | °C   |
| Operating Temperature                        | T <sub>opr</sub>  |                            | - 30 to 70                     | °C   |

RECOMMENDED OPERATING CONDITIONS (V<sub>SS</sub> = 0 V, T<sub>opr</sub> = - 30 to 70 °C)

| PARAMETER          | SYMBOL           | PINS                    | CONDITIONS                   | Min.                   | Max.                   | UNIT |
|--------------------|------------------|-------------------------|------------------------------|------------------------|------------------------|------|
| Supply Voltage     | V <sub>DD</sub>  |                         | In the Normal operating mode | 4.5                    | 6.0                    | V    |
|                    |                  |                         | In the Hold operating mode   | 2.0                    |                        |      |
| Input High Voltage | V <sub>IH1</sub> | Except Hysteresis Input | V <sub>DD</sub> ≥ 4.5 V      | V <sub>DD</sub> × 0.7  | V <sub>DD</sub>        | V    |
|                    | V <sub>IH2</sub> | Hysteresis Input        |                              | V <sub>DD</sub> × 0.75 |                        |      |
|                    | V <sub>IH3</sub> |                         | V <sub>DD</sub> < 4.5 V      | V <sub>DD</sub> × 0.9  |                        |      |
| Input Low Voltage  | V <sub>IL1</sub> | Except Hysteresis Input | V <sub>DD</sub> ≥ 4.5 V      | 0                      | V <sub>DD</sub> × 0.3  | V    |
|                    | V <sub>IL2</sub> | Hysteresis Input        |                              |                        | V <sub>DD</sub> × 0.25 |      |
|                    | V <sub>IL3</sub> |                         | V <sub>DD</sub> < 4.5 V      |                        | V <sub>DD</sub> × 0.1  |      |
| Clock Frequency    | f <sub>c</sub>   |                         |                              | 0.4                    | 4.2                    | MHz  |

Note 1. Input Voltage V<sub>IH3</sub>, V<sub>IL3</sub> : in the HOLD operating mode.

Note 2. 1MHz is recommended as minimum frequency when SLF = 1. And 2MHz is when SLF = 0.

## D.C. CHARACTERISTICS

(V<sub>SS</sub> = 0 V, V<sub>DD</sub> = 4.5 to 6.0 V, T<sub>opr</sub> = -30 to 70 °C)

| PARAMETER                           | SYMBOL            | PINS                                    | CONDITIONS   | Min. | Typ. | Max. | UNIT |
|-------------------------------------|-------------------|---|--|------|------|------|------|
| Hysteresis Voltage                  | V <sub>HS</sub>   | Hysteresis Input                        |  | —    | 0.7  | —    | V    |
| Input Current                       | I <sub>IN1</sub>  | Port K0, TEST, RESET, HOLD              | V <sub>DD</sub> = 5.5 V,   | —    | —    | ± 2  | μA   |
|                                     | I <sub>IN2</sub>  | Ports R (open drain)                    | V <sub>IN</sub> = 5.5 V / 0 V  |      |      |      |      |
| Low Input Current                   | I <sub>IL</sub>   | Ports R (push-pull)                     | V <sub>DD</sub> = 5.5 V, V <sub>IN</sub> = 0.4 V                                     | —    | —    | - 2  | mA   |
| Input Resistance                    | R <sub>IN1</sub>  | Port K0 with pull-up/pull-down resistor |  | 30   | 70   | 150  | kΩ   |
|                                     | R <sub>IN2</sub>  | RESET                                   |  | 100  | 220  | 450  |      |
| Output Leakage Current              | I <sub>LO</sub>   | Ports R (open drain)                    | V <sub>DD</sub> = 5.5 V, V <sub>OUT</sub> = 5.5 V                                    | —    | —    | 2    | μA   |
| Output High Voltage                 | V <sub>OH</sub>   | Ports R (push-pull)                     | V <sub>DD</sub> = 4.5 V, I <sub>OH</sub> = - 200 μA                                  | 2.4  | —    | —    | V    |
| Output Low Voltage                  | V <sub>OL2</sub>  | Except XOUT                             | V <sub>DD</sub> = 4.5 V, I <sub>OL</sub> = 1.6 mA                                    | —    | —    | 0.4  | V    |
| Segment Output Low Resistance       | R <sub>OS1</sub>  | SEG pin                                 | V <sub>DD</sub> = 5 V, V <sub>DD</sub> - V <sub>LC</sub> = 3 V                       | —    | 10   | —    | kΩ   |
| Common Output Low Resistance        | R <sub>OC1</sub>  | COM pin                                 |  |      |      |      |      |
| Segment Output High Resistance      | R <sub>OS2</sub>  | SEG pin                                 |  |      |      |      |      |
| Common Output High Resistance       | R <sub>OC2</sub>  | COM pin                                 |  |      |      |      |      |
| Segment / Common Output Voltage     | V <sub>O2/3</sub> | SEG / COM pin                           |  | 3.8  | 4.0  | 4.2  | V    |
|                                     | V <sub>O1/2</sub> |   |  | 3.3  | 3.5  | 3.7  |      |
|                                     | V <sub>O1/3</sub> |   |  | 2.8  | 3.0  | 3.2  |      |
| Supply Current (in the Normal mode) | I <sub>DD</sub>   |   | V <sub>DD</sub> = 5.5 V, V <sub>LC</sub> = V <sub>SS</sub><br>f <sub>c</sub> = 4 MHz | —    | 3    | 6    | mA   |
| Supply Current (in the HOLD mode)   | I <sub>DDH</sub>  |   | V <sub>DD</sub> = 5.5 V  | —    | 0.5  | 10   | μA   |

Note1. Typ. values show those at T<sub>opr</sub> = 25 °C, V<sub>DD</sub> = 5 V.

Note2. Input Current I<sub>IN1</sub> : The current through resistor is not included, when the input resistor (pull-up / pull-down) is contained.

Note3. Output resistance R<sub>OS</sub>, R<sub>OC</sub> : indicates the on resistance during level switching.

Note4. V<sub>O2/3</sub> : indicates 2/3 level output voltage when driving at 1/4 or 1/3 duty.

Note5. V<sub>O1/2</sub> : indicates 1/2 level output voltage for 1/2 duty or static drive.

Note6. V<sub>O1/3</sub> : indicates 1/3 level output voltage when driving at 1/4 or 1/3 duty.

Note7. Supply Current : V<sub>IN</sub> = 5.3 V / 0.2 V.

The voltage applied to the port R is within the valid range V<sub>IL</sub> or V<sub>IH</sub>.

Note 8. When using LCD, it is necessary to consider values of R<sub>OS1/2</sub> and R<sub>OC1/2</sub>.

Note 9. Times for SEG / COM output resistance switching on :

$$R_{OS1}, R_{OC1} : 2/f_s (s)$$

$$R_{OS2}, R_{OC2} : 1/(n \cdot f_F) \quad (1/n : \text{duty}, f_F : \text{frame frequency})$$

**A.C. CHARACTERISTICS** ( $V_{SS} = 0\text{ V}$ ,  $V_{DD} = 4.5\text{ to }6.0\text{ V}$ ,  $T_{opr} = -30\text{ to }70\text{ }^\circ\text{C}$ )

| PARAMETER                    | SYMBOL    | CONDITIONS          | Min.               | Typ. | Max. | UNIT          |
|------------------------------|-----------|---------------------|--------------------|------|------|---------------|
| Instruction Cycle Time       | $t_{cy}$  |                     | 1.9                | —    | 20   | $\mu\text{s}$ |
| High level Clock pulse Width | $t_{WCH}$ | External clock mode | 80                 | —    | —    | ns            |
| Low level Clock pulse Width  | $t_{WCL}$ |                     |                    |      |      |               |
| Shift data Hold Time         | $t_{SDH}$ |                     | $0.5 t_{cy} - 300$ | —    | —    | ns            |

**Note.** Shift data Hold Time:

External circuit for  $\overline{\text{SCK}}$  pin and SO pin

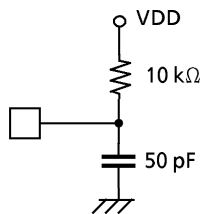

Serial port (completion of transmission)

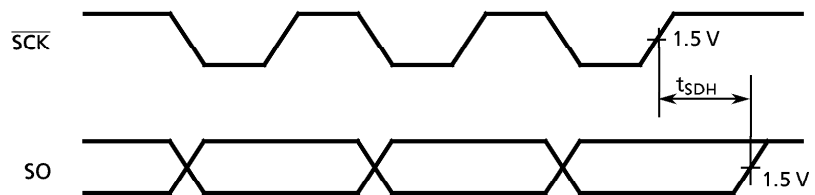

**RECOMMENDED OSCILLATING CONDITIONS** ( $V_{SS} = 0\text{ V}$ ,  $V_{DD} = 4.5\text{ to }6.0\text{ V}$ ,  $T_{opr} = -30\text{ to }70\text{ }^\circ\text{C}$ )

(1) 4 MHz

Ceramic Resonator

CSA4.00MG (MURATA)

$C_{XIN} = C_{XOUT} = 30\text{ pF}$

KBR-4.00MS (KYOCERA)

$C_{XIN} = C_{XOUT} = 30\text{ pF}$

Crystal Oscillator

204B-6F 4.0000 (TOYOCOM)

$C_{XIN} = C_{XOUT} = 20\text{ pF}$

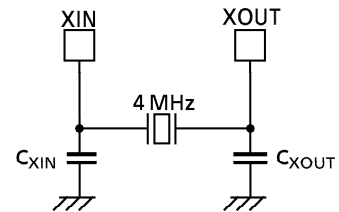

(2) 400 kHz

Ceramic Resonator

CSB400B (MURATA)

$C_{XIN} = C_{XOUT} = 220\text{ pF}$ ,  $R_{XOUT} = 6.8\text{ k}\Omega$

KBR-400B (KYOCERA)

$C_{XIN} = C_{XOUT} = 100\text{ pF}$ ,  $R_{XOUT} = 10\text{ k}\Omega$

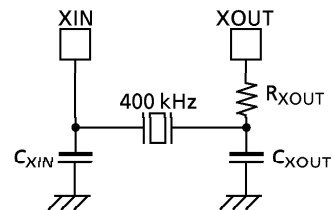

TYPICAL CHARACTERISTICS

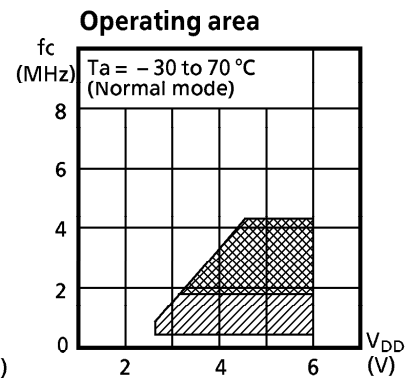
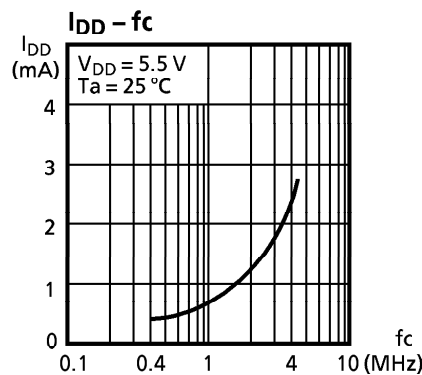
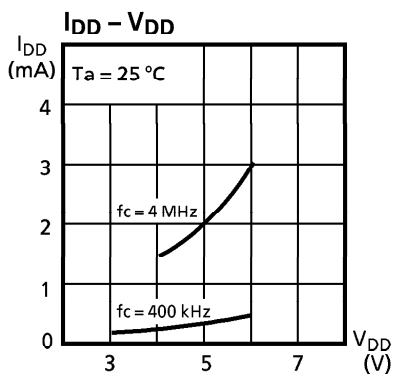
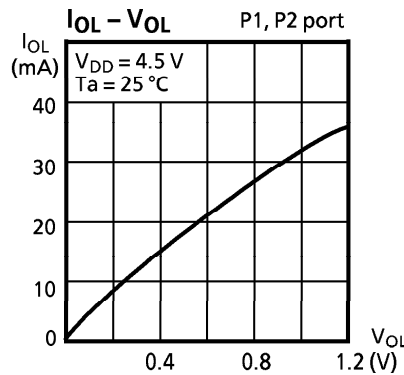
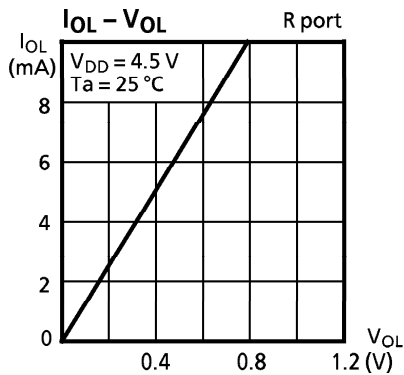
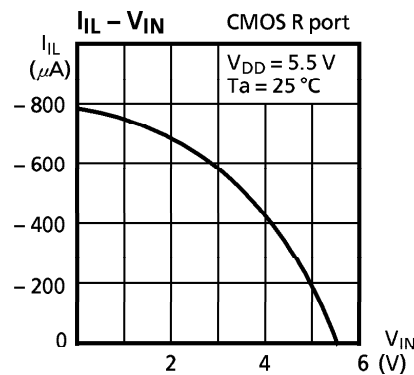
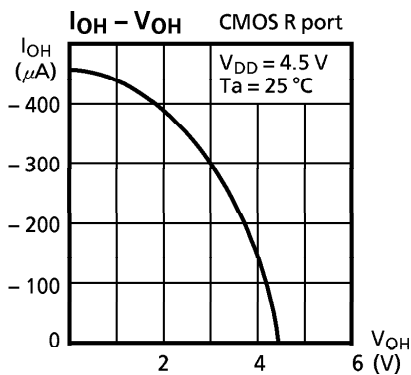
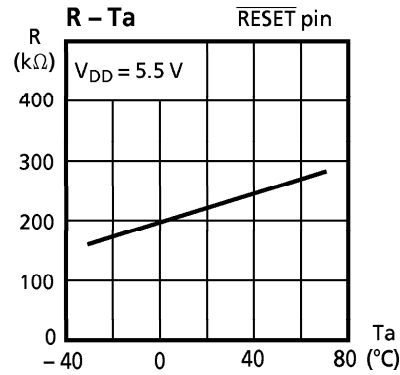
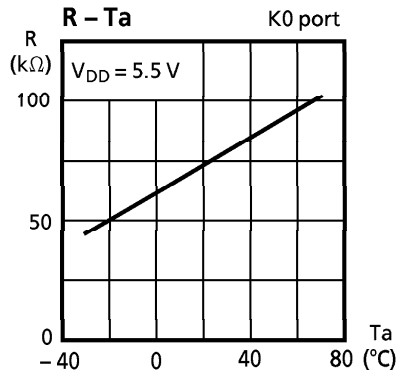

( ; LCD operation)

Note . 1 MHz is recommended as minimum frequency when SLF = 1. And 2 MHz is when SLF = 0.