

AT27HC256R/RL

Features

- Bipolar Speed in JEDEC Standard EPROM Pinout
Read Access Time - 55ns
28-Lead 600 mil CERDIP and OTP Plastic DIP
32-Pad LCC, JLCC and OTP PLCC
- Low Power CMOS Operation
100 μ A max. Standby
50 mA max. Active at 10 MHz
- High Output Drive Capability
- High Reliability Latch-Up Resistant CMOS Technology
- Rapid Programming - 100 μ s/byte (typical)
- Two-line Control
- CMOS and TTL Compatible Inputs and Outputs
- Integrated Product Identification Code
- Full Military, Industrial and Commercial Temperature Ranges
- Fully Compatible with AT27HC256/L

T-46-13-29
T-46-13-25

Block Diagram

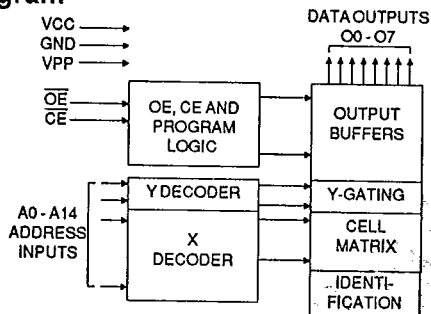

256K (32K x 8)
High Speed
UV
Erasable
CMOS
EPROM



Preliminary

Description

The AT27HC256R/RL chip family is a high-speed, low-power 262,144 bit Ultraviolet Erasable and Electrically Programmable Read Only Memory (EPROM) organized as 32K x 8 bits. The AT27HC256R is suited for very high-speed applications, while the AT27HC256RL features low Vcc Standby Current. Both require only one 5V power supply in normal read mode operation. Any byte can be accessed in less than 55ns on the AT27HC256, making this part ideal for high-performance systems. Power consumption is typically only 35mA in Active Mode on both parts, and less than 10 μ A in Standby Mode on the AT27HC256RL or 15mA on the AT27HC256R.

Atmel's 1.2-micron, high-speed CMOS technology provides optimum speed, lower power and high noise immunity. The high-speed CMOS process is an extension of Atmel's high quality and highly manufacturable floating poly EPROM technology.

Pin Configurations

Pin Name	Function
A0-A14	Addresses
CE	Chip Enable
OE	Output Enable
NC	No Connect
O0-O7	Outputs

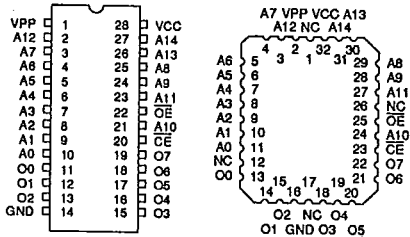

Note: PLCC package pins 1 and 17 are DON'T CONNECT.





T-46-13-29

T-46-13-25

Description (Continued)

The AT27HC256R/256RL come in a choice of industry standard JEDEC-approved packages including: 28-pin DIP ceramic or one time programmable (OTP) plastic, 32-pad ceramic leadless chip carrier (LCC), and 32-lead ceramic (JLCC), or OTP plastic (PLCC) J-leaded chip carrier. The device features two-line control (\overline{CE} , \overline{OE}) to give designers the flexibility to prevent bus contention.

With a storage capacity of 32K bytes, Atmel's 27HC256R/256RL allow firmware to be stored reliably and to be accessed at very high speeds. The AT27HC256R/256RL have exceptional output drive capability - source 4mA and sink 16mA per output.

The AT27HC256R/256RL have additional features to ensure high-quality and efficient production use. The Rapid programming algorithm reduces the time required to program the chip and guarantees reliable programming. The Integrated Product Identification Code electronically identifies the device and manufacturing origin. This feature is used by industry standard programming equipment to select the proper programming algorithms and voltages.

Erasure Characteristics

The entire memory array of the AT27HC256R/256RL is erased (all outputs read as V_{OH}) after exposure to ultraviolet light at a wavelength of 2537Å. Complete erasure is assured after a minimum of 20 minutes exposure using 12,000 $\mu W/cm^2$ intensity lamps spaced one inch away from the chip. Minimum erase time for lamps at other intensity ratings can be calculated from the minimum integrated erasure dose of 15W·sec/cm². To prevent unintentional erasure, an opaque label is recommended to cover the clear window on any UV erasable EPROM which will be subjected to continuous fluorescent indoor lighting or sunlight.

Absolute Maximum Ratings*

Temperature Under Bias	-55°C to +125°C
Storage Temperature.....	-65°C to +150°C
Voltage on Any Pin with Respect to Ground.....	-2.0V to +7.0V ⁽¹⁾
Voltage on A9 with Respect to Ground	-2.0V to +14.0V ⁽¹⁾
V _{pp} Supply Voltage with Respect to Ground.....	-2.0V to +14.0V ⁽¹⁾
Integrated UV Erase Dose.....	7258 W·sec/cm ²

*NOTICE: Stresses beyond those listed under "Absolute Maximum Ratings" may cause permanent damage to the device. This is a stress rating only and functional operation of the device at these or any other conditions beyond those indicated in the operational sections of this specification is not implied. Exposure to absolute maximum rating conditions for extended periods may affect device reliability.

Notes:

1. Minimum voltage is -0.6V dc which may undershoot to -2.0V for pulses of less than 20ns. Maximum output pin voltage is $V_{CC}+0.75V$ dc which may overshoot to +7.0V for pulses of less than 20ns.

Operating Modes

MODE \ PIN	\overline{CE}	\overline{OE}	Ai	V _{pp}	V _{cc}	Outputs
Read	V _{IL}	V _{IL}	Ai	V _{CC}	V _{CC}	DOUT
Output Disable	V _{IL}	V _{IH}	X ⁽¹⁾	V _{CC}	V _{CC}	High Z
Standby	V _{IH}	X	X	V _{CC}	V _{CC}	High Z
Rapid Program ⁽²⁾	V _{IL}	V _{IH}	Ai	V _{PP}	V _{CC}	DIN
PGM Verify ⁽²⁾	X	V _{IL}	Ai	V _{PP}	V _{CC}	DOUT
Optional PGM Verify ⁽²⁾	V _{IL}	V _{IL}	Ai	V _{CC}	V _{CC}	DOUT
PGM Inhibit ⁽²⁾	V _{IH}	V _{IH}	X	V _{PP}	V _{CC}	High Z
Product Identification ⁽⁴⁾	V _{IL}	V _{IL}	A9=V _H ⁽³⁾ A0=V _{IH} or V _{IL} A1-A14=V _{IL}	V _{CC}	V _{CC}	Identification Code

1. X can be V_{IL} or V_{IH}.
2. Refer to Programming characteristics.
3. V_H = 12.0 ± 0.5V.

4. Two identifier bytes may be selected. All Ai inputs are held low (V_{IL}), except A9 which is set to V_H and A0 which is toggled low (V_{IL}) to select the Manufacturer's Identification byte and high (V_{IH}) to select the Device Code byte.

AT27HC256R/RL

T-46-13-29

D.C. and A.C. Operating Conditions for Read Operation

T-46-13-25

AT27HC256R		AT27HC256R / AT27HC256RL			
		-55	-70	-90	-12
Operating Temperature (Case)	Com.	0°C - 70°C	0°C - 70°C	0°C - 70°C	0°C - 70°C
	Ind.	-40°C - 85°C	-40°C - 85°C	-40°C - 85°C	-40°C - 85°C
	Mil.		-55°C - 125°C ⁽¹⁾	-55°C - 125°C	-55°C - 125°C
V _{CC} Power Supply		5V ± 10%	5V ± 10%	5V ± 10%	5V ± 10%

Notes: 1. AT27HC256R only.

D.C. and Operating Characteristics for Read Operation

Symbol	Parameter	Condition	Min	Max	Units
I _{LI}	Input Load Current	V _{IN} =-0.1V to V _{CC} +1V		10	µA
I _{LO}	Output Leakage Current	V _{OUT} =-0.1V to V _{CC} +0.1V		10	µA
I _{PP} ⁽²⁾	V _{PP} ⁽¹⁾ Read/Standby Current	V _{PP} =3.8 to V _{CC} +0.3V		20	µA
I _{SB1} /I _{SB2}	V _{CC} ⁽¹⁾ Standby Current	I _{SB1} (CMOS) C _E =V _{CC} -0.3 to V _{CC} +1.0V	AT27HC256RL Com. Ind.,Mil.		0.1/2 0.2/3 mA mA
		I _{SB2} (TTL) C _E =2.0 to V _{CC} +1.0V	AT27HC256R Com. Ind.,Mil.		30/35 30/35 mA mA
I _{CC}	V _{CC} Active Current	f=10MHz, I _{OUT} =0mA, C _E =V _{IL}	Com. Ind.,Mil.		50 55 mA mA
V _{IL}	Input Low Voltage		-0.6	0.8	V
V _{IH}	Input High Voltage		2.0	V _{CC} +1	V
V _{OL}	Output Low Voltage	I _{OL} =16mA		.45	V
V _{OH}	Output High Voltage	I _{OH} =-100µA	V _{CC} -0.3		V
		I _{OH} =-2.5mA	3.5		V
		I _{OH} =-4.0mA	2.4		V
V _{PP}	V _{PP} Read Voltage	V _{CC} =5 ± 0.5V	3.8	V _{CC} +0.3	V

Notes: 1. V_{CC} must be applied simultaneously or before V_{PP}, and removed simultaneously or after V_{PP}.
 2. V_{PP} may be connected directly to V_{CC}, except during programming. The supply current would then be the sum of I_{CC} and I_{PP}.

A.C. Characteristics for Read Operation

Symbol	Parameter	Condition	AT27HC256R		AT27HC256R / AT27HC256RL				Units
			-55	-70	-90	-12			
t _{ACC} ⁽⁴⁾	Address to Output Delay	C _E = \overline{OE} =V _{IL}	Com.,Ind.		55	70	90	120	ns
			Mil.			70 ⁽¹⁾	90	120	ns
t _{CE} ⁽³⁾	C _E to Output Delay	\overline{OE} =V _{IL}			55	70	90	120	ns
t _{OE} ^(3,4)	\overline{OE} to Output Delay	\overline{OE} =V _{IL}			25	30	30	35	ns
t _{DF} ^(2,5)	\overline{OE} or C _E High to Output Float	\overline{OE} =V _{IL}			25	30	30	35	ns
t _{OH}	Output Hold from Address, C _E or \overline{OE} , whichever occurred first	\overline{OE} = \overline{OE} =V _{IL}			0	0	0	0	ns

Notes: 1. AT27HC256R only. 2, 3, 4, 5. - see AC Waveforms for Read Operation.





T-46-13-29

T-46-13-25

A.C. Waveforms for Read Operation ⁽¹⁾

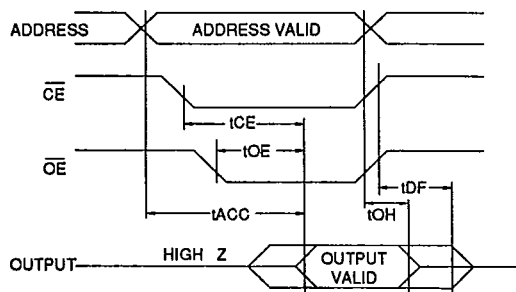

Notes:

1. Timing measurement reference is 1.5V. Input AC driving levels are 0.0V and 3.0V, unless otherwise specified. $C_L = 30\text{pF}$, add 10ns for $C_L = 100\text{pF}$.
2. t_{DF} is specified from \overline{OE} or \overline{CE} , whichever occurs first. t_{DF} is measured at $V_{OH}-0.5V$ or $V_{OL}+0.5V$ with $C_L=5\text{pF}$.
3. \overline{OE} may be delayed up to $t_{CE}-t_{OE}$ after the falling edge of \overline{CE} without impact on t_{CE} .
4. \overline{OE} may be delayed up to $t_{ACC}-t_{OE}$ after the address is valid without impact on t_{ACC} .
5. This parameter is only sampled and is not 100% tested.

Input Test Waveforms and Measurement Levels

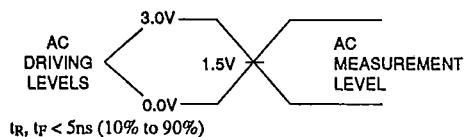

Output Test Load

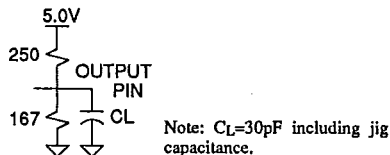

Note: $C_L=30\text{pF}$ including jig capacitance.

Pin Capacitance ($f=1\text{MHz}$ $T=25^\circ\text{C}$) ⁽¹⁾

	Typ	Max	Units	Conditions
C_{IN}	4	6	pF	$V_{IN} = 0V$
C_{OUT}	8	12	pF	$V_{OUT} = 0V$

Notes: 1. Typical values for nominal supply voltage. This parameter is only sampled and is not 100% tested.

Programming Waveforms ⁽¹⁾

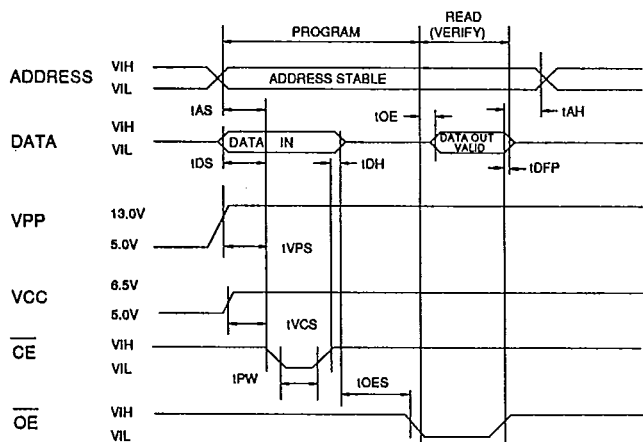

Notes:

1. The Input Timing Reference is 0.0V for V_{IL} and 3.0V for V_{IH} .
2. t_{OE} and t_{DFP} are characteristics of the device but must be accommodated by the programmer.
3. When programming the AT27HC256R/256RL a 0.1 μF capacitor is required across V_{pp} and ground to suppress spurious voltage transients.

T-46-13-29

AT27HC256R/RL

T-46-13-25

D.C. Programming Characteristics

T_A=25±5°C, V_{CC}=6.5±0.25V, V_{PP}=13.0±0.25V

Sym- bol	Parameter	Test Conditions	Limits		Units
			Min	Max	
I _{LI}	Input Load Current	V _{IN} =V _{IL} ,V _{IH}		10	μA
V _{IL}	Input Low Level	(All Inputs)	-0.6	0.8	V
V _{IH}	Input High Level		2.0	V _{CC} +1	V
V _{OL}	Output Low Volt.	I _{OL} =16mA		.45	V
V _{OH}	Output High Volt.	I _{OH} =-4.0mA	2.4		V
I _{CC2}	V _{CC} Supply Current (Program and Verify)			60	mA
I _{PP2}	V _{PP} Supply Current	C _E =V _{IL}		30	mA
V _{ID}	A9 Product Identifi- cation Voltage		11.5	12.5	V

Atmel's 27HC256R/RL Integrated Product Identification Code:

Codes	Pins								Hex Data	
	A0	O7	O6	O5	O4	O3	O2	O1		O0
Manufacturer	0	0	0	0	1	1	1	1	0	1E
Device Type	1	1	0	0	1	0	1	0	0	94

Rapid Programming Algorithm

A 100μs C_E pulse width is used to program. The address is set to the first location. V_{CC} is raised to 6.5V and V_{PP} is raised to 13.0V. Each address is first programmed with one 100μs C_E pulse without verification. Then a verification/reprogramming loop is executed for each address. In the event a byte fails to pass verification, up to 10 successive 100μs pulses are applied with a verification after each pulse. If the byte fails to verify after 10 pulses have been applied, the part is considered failed. After the byte verifies properly, the next address is selected until all have been checked. V_{PP} is then lowered to 5.0V and V_{CC} to 5.0V. All bytes are read again and compared with the original data to determine if the device passes or fails.



A.C. Programming Characteristics

T_A=25±5°C, V_{CC}=6.5±0.25V, V_{PP}=13.0±0.25V

Sym- bol	Parameter	Test Conditions* (see Note 1)	Limits		Units
			Min	Max	
t _{AS}	Address Setup Time		2		μs
t _{OES}	O _E Setup Time		2		μs
t _{DS}	Data Setup Time		2		μs
t _{AH}	Address Hold Time		0		μs
t _{DH}	Data Hold Time		2		μs
t _{DFP}	O _E High to Out- put Float Delay	(Note 2)	0	130	ns
t _{VPS}	V _{PP} Setup Time		2		μs
t _{VCS}	V _{CC} Setup Time		2		μs
t _{PW}	C _E Program Pulse Width	(Note 3)	95	105	μs
t _{OE}	Data Valid from O _E			150	ns

*A.C. Conditions of Test:

- Input Rise and Fall Times (10% to 90%)5ns
- Input Pulse Levels0.0V to 3.0V
- Input Timing Reference Level1.5V
- Output Timing Reference Level1.5V

Notes:

- V_{CC} must be applied simultaneously or before V_{PP} and re-
moved simultaneously or after V_{PP}.
- This parameter is only sampled and is not 100% tested.
Output Float is defined as the point where data is no longer
driven — see timing diagram.
- Program Pulse width tolerance is 100μsec±5%.

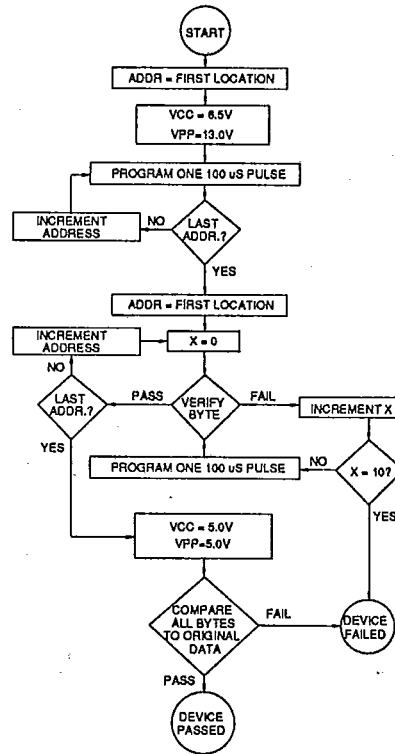



T-46-13-29

T-46-13-25

Ordering Information

tAcc (ns)	Icc (mA)		Ordering Code	Package	Operation Range
	Active	Standby			
55	50	30	AT27HC256R-55DC AT27HC256R-55KC AT27HC256R-55LC	28DW6 32KW 32LW	Commercial (0°C to 70°C)
55	55	35	AT27HC256R-55DI AT27HC256R-55KI AT27HC256R-55LI	28DW6 32KW 32LW	Industrial (-40°C to 85°C)
70	50	30	AT27HC256R-70DC AT27HC256R-70JC AT27HC256R-70KC AT27HC256R-70LC AT27HC256R-70PC	28DW6 32J 32KW 32LW 28P6	Commercial (0°C to 70°C)
70	55	35	AT27HC256R-70DI AT27HC256R-70JI AT27HC256R-70KI AT27HC256R-70LI AT27HC256R-70PI	28DW6 32J 32KW 32LW 28P6	Industrial (-40°C to 85°C)
			AT27HC256R-70DM AT27HC256R-70KM AT27HC256R-70LM	28DW6 32KW 32LW	Military (-55°C to 125°C)
			AT27HC256R-70DM/883 AT27HC256R-70KM/883 AT27HC256R-70LM/883	28DW6 32KW 32LW	Military/883C Class B, Fully Compliant (-55°C to 125°C)
90	50	30	AT27HC256R-90DC AT27HC256R-90JC AT27HC256R-90KC AT27HC256R-90LC AT27HC256R-90PC	28DW6 32J 32KW 32LW 28P6	Commercial (0°C to 70°C)
90	55	35	AT27HC256R-90DI AT27HC256R-90JI AT27HC256R-90KI AT27HC256R-90LI AT27HC256R-90PI	28DW6 32J 32KW 32LW 28P6	Industrial (-40°C to 85°C)
			AT27HC256R-90DM AT27HC256R-90KM AT27HC256R-90LM	28DW6 32KW 32LW	Military (-55°C to 125°C)
			AT27HC256R-90DM/883 AT27HC256R-90KM/883 AT27HC256R-90LM/883	28DW6 32KW 32LW	Military/883C Class B, Fully Compliant (-55°C to 125°C)
120	50	30	AT27HC256R-12DC AT27HC256R-12JC AT27HC256R-12KC AT27HC256R-12LC AT27HC256R-12PC	28DW6 32J 32KW 32LW 28P6	Commercial (0°C to 70°C)

AT27HC256R/RL

T-46-13-29

T-46-13-25

Ordering Information

t _{ACC} (ns)	I _{CC} (mA)		Ordering Code	Package	Operation Range
	Active	Standby			
120	55	35	AT27HC256R-12DI	28DW6	Industrial (-40°C to 85°C)
			AT27HC256R-12JI	32J	
			AT27HC256R-12KI	32KW	
			AT27HC256R-12LI	32LW	
			AT27HC256R-12PI	28P6	
			AT27HC256R-12DM	28DW6	Military (-55°C to 125°C)
			AT27HC256R-12KM	32KW	
			AT27HC256R-12LM	32LW	
			AT27HC256R-12DM/883	28DW6	Military/883C Class B, Fully Compliant (-55°C to 125°C)
			AT27HC256R-12KM/883	32KW	
			AT27HC256R-12LM/883	32LW	
70	55	35	5962-86063 08 XX	28DW6	Military/883C Class B, Fully Compliant (-55°C to 125°C)
			5962-86063 08 YX	32LW	



Package Type	
28DW6	28 Lead, 0.600" Wide, Windowed, Ceramic Dual Inline Package (Cerdip)
32J	32 Lead, Plastic J-Leaded Chip Carrier OTP (PLCC)
32KW	32 Lead, Windowed, Ceramic J-Leaded Chip Carrier (JLCC)
32LW	32 Pad, Windowed, Ceramic Leadless Chip Carrier (LCC)
28P6	28 Lead, 0.600" Wide, Plastic Dual Inline Package OTP (PDIP)





T-46-13-29

T-46-13-25

Ordering Information

I _{acc} (ns)	I _{cc} (mA)		Ordering Code	Package	Operation Range
	Active	Standby			
70	50	0.1	AT27HC256RL-70DC AT27HC256RL-70KC AT27HC256RL-70LC	28DW6 32KW 32LW	Commercial (0°C to 70°C)
70	55	0.2	AT27HC256RL-70DI AT27HC256RL-70KI AT27HC256RL-70LI	28DW6 32KW 32LW	Industrial (-40°C to 85°C)
90	50	0.1	AT27HC256RL-90DC AT27HC256RL-90JC AT27HC256RL-90KC AT27HC256RL-90LC AT27HC256RL-90PC	28DW6 32J 32KW 32LW 28P6	Commercial (0°C to 70°C)
90	55	0.2	AT27HC256RL-90DI AT27HC256RL-90JI AT27HC256RL-90KI AT27HC256RL-90LI AT27HC256RL-90PI	28DW6 32J 32KW 32LW 28P6	Industrial (-40°C to 85°C)
			AT27HC256RL-90DM AT27HC256RL-90KM AT27HC256RL-90LM	28DW6 32KW 32LW	Military (-55°C to 125°C)
			AT27HC256RL-90DM/883 AT27HC256RL-90KM/883 AT27HC256RL-90LM/883	28DW6 32KW 32LW	Military/883C Class B, Fully Compliant (-55°C to 125°C)
120	50	0.1	AT27HC256RL-12DC AT27HC256RL-12JC AT27HC256RL-12KC AT27HC256RL-12LC AT27HC256RL-12PC	28DW6 32J 32KW 32LW 28P6	Commercial (0°C to 70°C)
120	55	0.2	AT27HC256RL-12DI AT27HC256RL-12JI AT27HC256RL-12KI AT27HC256RL-12LI AT27HC256RL-12PI	28DW6 32J 32KW 32LW 28P6	Industrial (-40°C to 85°C)
			AT27HC256RL-12DM AT27HC256RL-12KM AT27HC256RL-12LM	28DW6 32KW 32LW	Military (-55°C to 125°C)
			AT27HC256RL-12DM/883 AT27HC256RL-12KM/883 AT27HC256RL-12LM/883	28DW6 32KW 32LW	Military/883C Class B, Fully Compliant (-55°C to 125°C)
90	55	0.2	5962-86063 07 XX 5962-86063 07 YX	28DW6 32LW	Military/883C Class B, Fully Compliant (-55°C to 125°C)
120	55	0.2	5962-86063 06 XX 5962-86063 06 YX	28DW6 32LW	Military/883C Class B, Fully Compliant (-55°C to 125°C)

AT27HC256R/RL

T-46-13-29

T-46-13-25

Ordering Information

Package Type	
28DW6	28 Lead, 0.600" Wide, Windowed, Ceramic Dual Inline Package (Cerdip)
32J	32 Lead, Plastic J-Leaded Chip Carrier OTP (PLCC)
32KW	32 Lead, Windowed, Ceramic J-Leaded Chip Carrier (JLCC)
32LW	32 Pad, Windowed, Ceramic Leadless Chip Carrier (LCC)
28P6	28 Lead, 0.600" Wide, Plastic Dual Inline Package OTP (PDIP)

