

256K x 16 Static RAM

Features

- High speed
 - $t_{AA} = 12 \text{ ns}$
- Low active power
 - 612 mW (max.)
- Low CMOS standby power (Commercial L version)
 - 1.8 mW (max.)
- 2.0V Data Retention (660 μW at 2.0V retention)
- Automatic power-down when deselected
- TTL-compatible inputs and outputs
- Easy memory expansion with $\overline{\text{CE}}$ and $\overline{\text{OE}}$ features

Functional Description

The CY7C1041BNV33 is a high-performance CMOS Static RAM organized as 262,144 words by 16 bits.

Writing to the device is accomplished by taking Chip Enable ($\overline{\text{CE}}$) and Write Enable ($\overline{\text{WE}}$) inputs LOW. If Byte Low Enable ($\overline{\text{BLE}}$) is LOW, then data from I/O pins (I/O_0 through I/O_7), is written into the location specified on the address pins (A_0 through A_{17}). If Byte High Enable ($\overline{\text{BHE}}$) is LOW, then data from I/O pins (I/O_8 through I/O_{15}) is written into the location specified on the address pins (A_0 through A_{17}).

Reading from the device is accomplished by taking Chip Enable ($\overline{\text{CE}}$) and Output Enable ($\overline{\text{OE}}$) LOW while forcing the Write Enable ($\overline{\text{WE}}$) HIGH. If Byte Low Enable ($\overline{\text{BLE}}$) is LOW, then data from the memory location specified by the address pins will appear on I/O_0 to I/O_7 . If Byte High Enable ($\overline{\text{BHE}}$) is LOW, then data from memory will appear on I/O_8 to I/O_{15} . See the truth table at the back of this data sheet for a complete description of read and write modes.

The input/output pins (I/O_0 through I/O_{15}) are placed in a high-impedance state when the device is deselected ($\overline{\text{CE}}$ HIGH), the outputs are disabled ($\overline{\text{OE}}$ HIGH), the $\overline{\text{BHE}}$ and $\overline{\text{BLE}}$ are disabled ($\overline{\text{BHE}}$, $\overline{\text{BLE}}$ HIGH), or during a write operation ($\overline{\text{CE}}$ LOW, and $\overline{\text{WE}}$ LOW).

The CY7C1041BNV33 is available in a standard 44-pin 400-mil-wide body width SOJ and 44-pin TSOP II package with center power and ground (revolutionary) pinout.

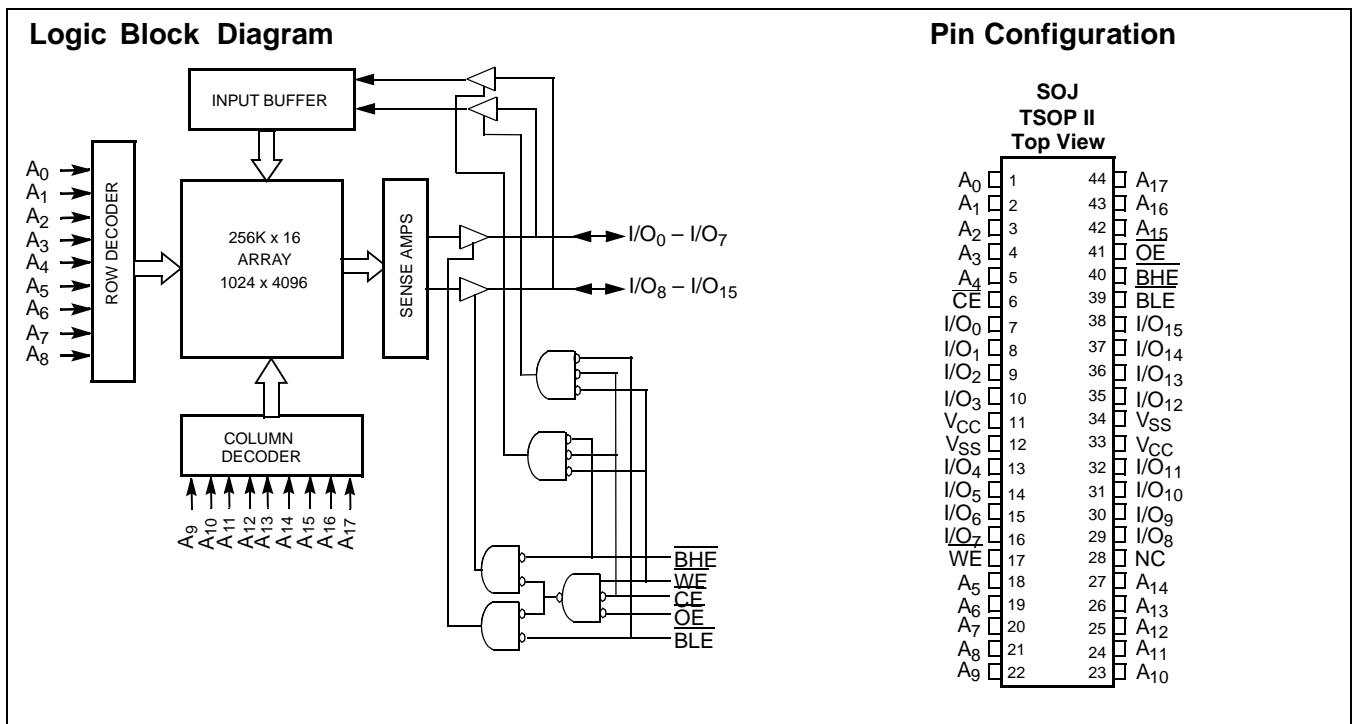

Selection Guide

		-12	-15
Maximum Access Time (ns)		12	15
Maximum Operating Current (mA)	Comm'l	190	170
	Ind'l	-	190
Maximum CMOS Standby Current (mA)	Com'l/Ind'l	8	8
	Com'l L	0.5	0.5

Maximum Ratings

(Above which the useful life may be impaired. For user guidelines, not tested.)

Storage Temperature -65°C to +150°C
 Ambient Temperature with Power Applied..... -55°C to +125°C
 Supply Voltage on V_{CC} to Relative GND^[1] -0.5V to +4.6V
 DC Voltage Applied to Outputs in High Z State^[1] -0.5V to V_{CC} + 0.5V

DC Input Voltage^[1] -0.5V to V_{CC} + 0.5V
 Current into Outputs (LOW)..... 20 mA

Operating Range

Range	Ambient Temperature ^[2]	V _{CC}
Commercial	0°C to +70°C	3.3V ± 0.3V
Industrial	-40°C to +85°C	

Electrical Characteristics Over the Operating Range

Parameter	Description	Test Conditions	-12		-15		Unit
			Min.	Max.	Min.	Max.	
V _{OH}	Output HIGH Voltage	V _{CC} = Min., I _{OH} = -4.0 mA	2.4		2.4		V
V _{OL}	Output LOW Voltage	V _{CC} = Min., I _{OL} = 8.0 mA		0.4		0.4	V
V _{IH}	Input HIGH Voltage		2.2	V _{CC} +0.5	2.2	V _{CC} +0.5	V
V _{IL}	Input LOW Voltage ^[1]		-0.5	0.8	-0.5	0.8	V
I _{Ix}	Input Leakage Current	GND ≤ V _I ≤ V _{CC}	-1	+1	-1	+1	mA
I _{oZ}	Output Leakage Current	GND ≤ V _{OUT} ≤ V _{CC} , Output Disabled	-1	+1	-1	+1	mA
I _{CC}	V _{CC} Operating Supply Current	V _{CC} = Max., f = f _{MAX} = 1/t _{RC}	Comm'l	190		170	mA
			Ind'l	-		190	mA
I _{SB1}	Automatic CE Power-Down Current — TTL Inputs	Max. V _{CC} , $\overline{CE} \geq V_{IH}$, V _{IN} ≥ V _{IH} or V _{IN} ≤ V _{IL} , f = f _{MAX}		40		40	mA
I _{SB2}	Automatic CE Power-Down Current — CMOS Inputs	Max. V _{CC} , $\overline{CE} \geq V_{CC} - 0.3V$, V _{IN} ≥ V _{CC} - 0.3V, or V _{IN} ≤ 0.3V, f = 0	Com'l/Ind'l	8		8	mA
			Com'l L	0.5		0.5	mA

Capacitance^[3]

Parameter	Description	Test Conditions	Max.	Unit
C _{IN}	Input Capacitance	T _A = 25°C, f = 1 MHz, V _{CC} = 3.3V	8	pF
C _{OUT}	I/O Capacitance		8	pF

AC Test Loads and Waveforms

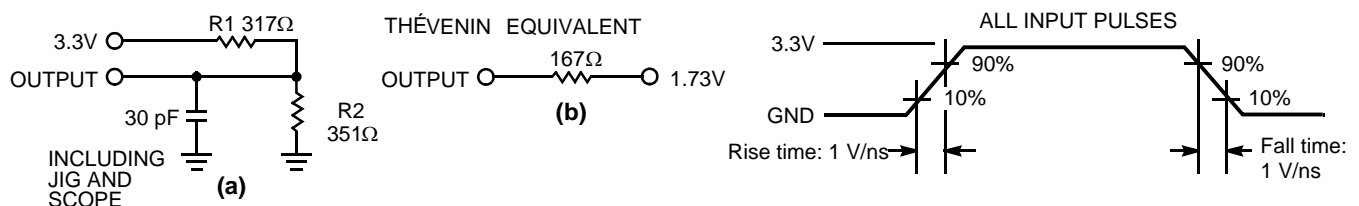

- Notes:**
- V_{IL} (min.) = -2.0V for pulse durations of less than 20 ns.
 - T_A is the "Instant On" case temperature.
 - Tested initially and after any design or process changes that may affect these parameters.

Switching Characteristics^[4] Over the Operating Range

Parameter	Description	-12		-15		Unit
		Min.	Max.	Min.	Max.	
READ CYCLE						
t _{RC}	Read Cycle Time	12		15		ns
t _{AA}	Address to Data Valid		12		15	ns
t _{OHA}	Data Hold from Address Change	3		3		ns
t _{ACE}	$\overline{\text{CE}}$ LOW to Data Valid		12		15	ns
t _{DOE}	$\overline{\text{OE}}$ LOW to Data Valid		6		7	ns
t _{LZOE}	$\overline{\text{OE}}$ LOW to Low Z	0		0		ns
t _{HZOE}	$\overline{\text{OE}}$ HIGH to High Z ^[5, 6]		6		7	ns
t _{LZCE}	$\overline{\text{CE}}$ LOW to Low Z ^[6]	3		3		ns
t _{HZCE}	$\overline{\text{CE}}$ HIGH to High Z ^[5, 6]		6		7	ns
t _{PU}	$\overline{\text{CE}}$ LOW to Power-Up	0		0		ns
t _{PD}	$\overline{\text{CE}}$ HIGH to Power-Down		12		15	ns
t _{DBE}	Byte Enable to Data Valid		6		7	ns
t _{LZBE}	Byte Enable to Low Z	0		0		ns
t _{HZBE}	Byte Disable to High Z		6		7	ns
WRITE CYCLE^[7, 8]						
t _{WC}	Write Cycle Time	12		15		ns
t _{SCE}	$\overline{\text{CE}}$ LOW to Write End	10		12		ns
t _{AW}	Address Set-Up to Write End	10		12		ns
t _{HA}	Address Hold from Write End	0		0		ns
t _{SA}	Address Set-Up to Write Start	0		0		ns
t _{PWE}	$\overline{\text{WE}}$ Pulse Width	10		12		ns
t _{SD}	Data Set-Up to Write End	7		8		ns
t _{HD}	Data Hold from Write End	0		0		ns
t _{LZWE}	$\overline{\text{WE}}$ HIGH to Low Z ^[6]	3		3		ns
t _{HZWE}	$\overline{\text{WE}}$ LOW to High Z ^[5, 6]		6		7	ns
t _{BW}	Byte Enable to End of Write	10		12		ns

Data Retention Characteristics Over the Operating Range (For L version only)

Parameter	Description	Conditions ^[10]	Min.	Max.	Unit
V _{DR}	V _{CC} for Data Retention		2.0		V
I _{CCDR}	Data Retention Current	V _{CC} = V _{DR} = 2.0V, CE ≥ V _{CC} - 0.3V, V _{IN} ≥ V _{CC} - 0.3V or V _{IN} ≤ 0.3V		330	μA
t _{CDR} ^[3]	Chip Deselect to Data Retention Time		0		ns
t _R ^[9]	Operation Recovery Time		t _{RC}		ns

Notes:

- Test conditions assume signal transition time of 3 ns or less, timing reference levels of 1.5V, input pulse levels of 0 to 3.0V, and output loading of the specified I_{OL}/I_{OH} and 30-pF load capacitance.
- t_{HZOE}, t_{HZCE}, and t_{HZWE} are specified with a load capacitance of 5 pF as in part (b) of AC Test Loads. Transition is measured ±500 mV from steady-state voltage.
- At any given temperature and voltage condition, t_{HZCE} is less than t_{LZCE}, t_{HZOE} is less than t_{LZOE}, and t_{HZWE} is less than t_{LZWE} for any given device.
- The internal write time of the memory is defined by the overlap of CE LOW, and WE LOW. CE and WE must be LOW to initiate a write, and the transition of either of these signals can terminate the write. The input data set-up and hold timing should be referenced to the leading edge of the signal that terminates the write.
- The minimum write cycle time for Write Cycle No. 3 (WE controlled, OE LOW) is the sum of t_{HZWE} and t_{SD}.
- t_r ≤ 3 ns for the -12 and -15 speeds.
- No input may exceed V_{CC} + 0.5V.

Data Retention Waveform

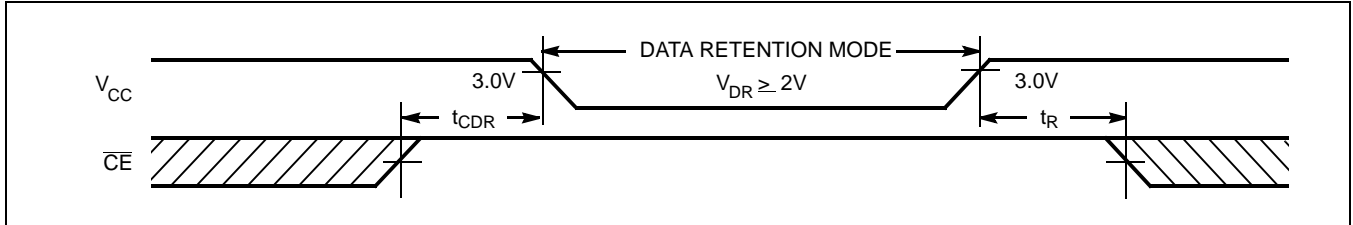

Switching Waveforms

Read Cycle No. 1^[11, 12]

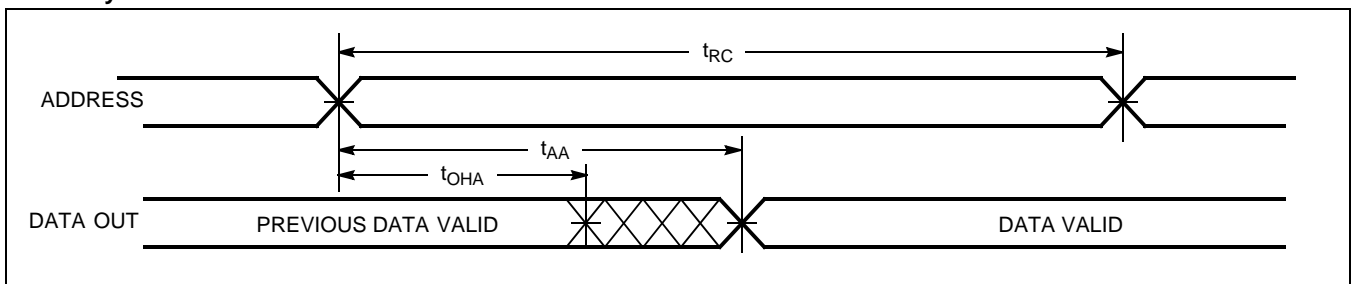

Read Cycle No. 2 (OE Controlled)^[12, 13]

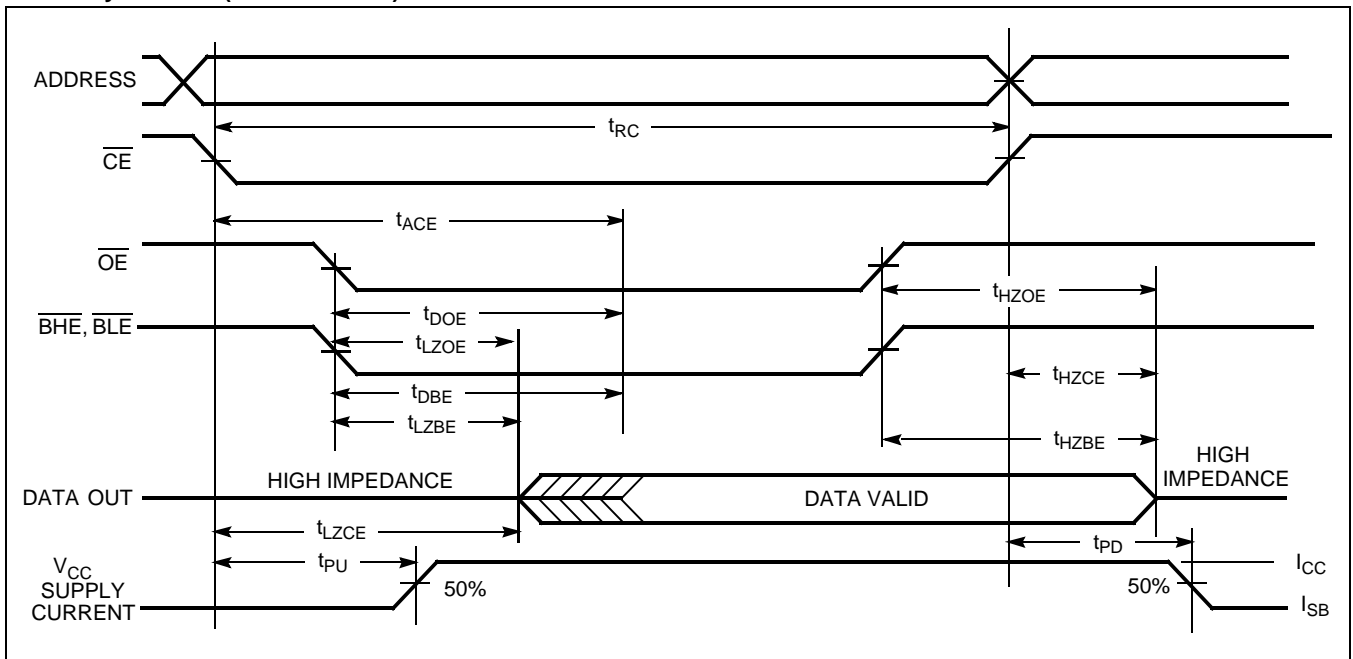

Notes:

- 11. Device is continuously selected. \overline{OE} , \overline{CE} , \overline{BHE} and/or \overline{BLE} = V_{IL} .
- 12. \overline{WE} is HIGH for read cycle.
- 13. Address valid prior to or coincident with \overline{CE} transition LOW.

Switching Waveforms (continued)

Write Cycle No. 1 ($\overline{\text{CE}}$ Controlled)^[14, 15]

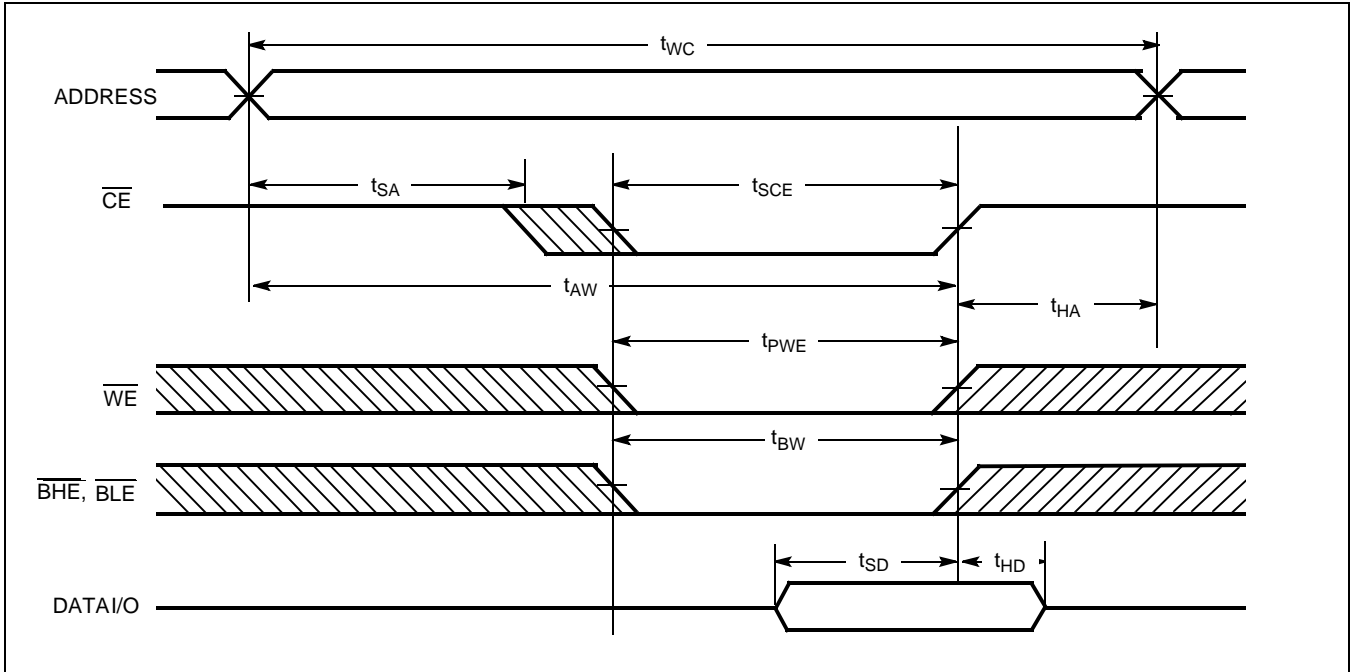

Write Cycle No. 2 ($\overline{\text{BLE}}$ or $\overline{\text{BHE}}$ Controlled)

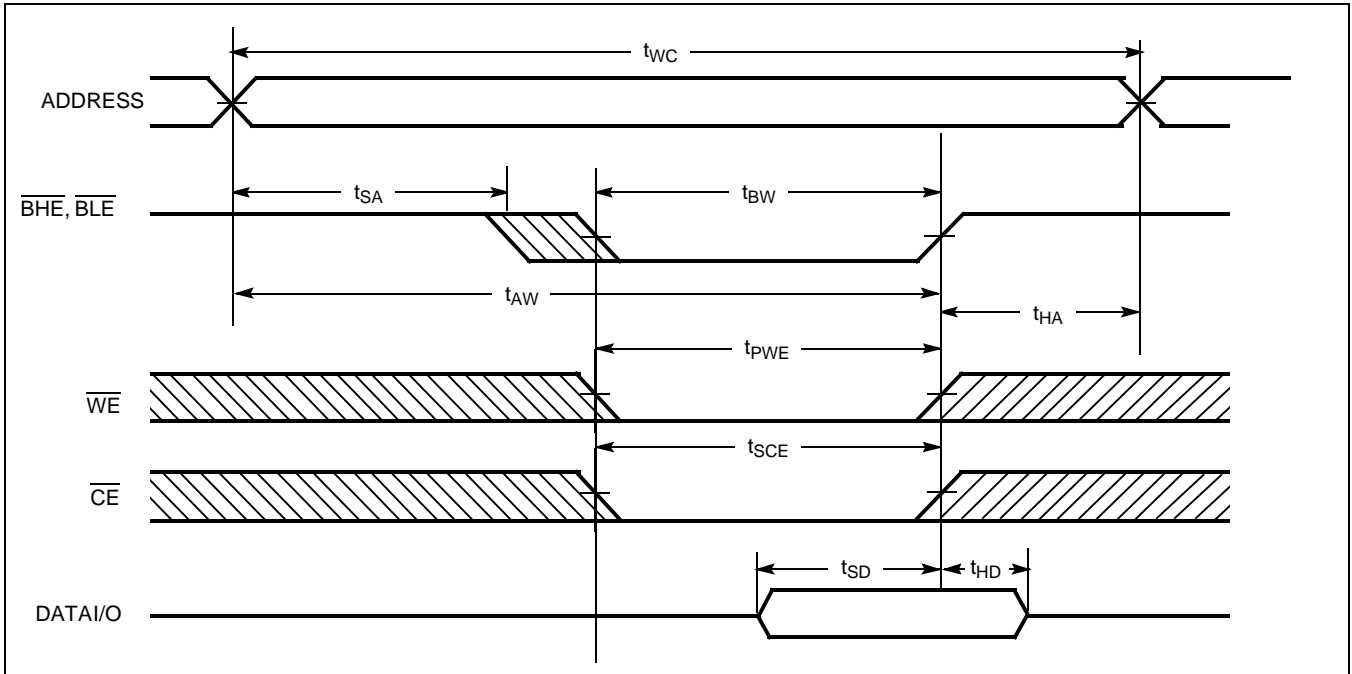

Notes:

- 14. Data I/O is high-impedance if $\overline{\text{OE}}$ or $\overline{\text{BHE}}$ and/or $\overline{\text{BLE}} = V_{IH}$.
- 15. If $\overline{\text{CE}}$ goes HIGH simultaneously with $\overline{\text{WE}}$ going HIGH, the output remains in a high-impedance state.

Switching Waveforms (continued)

Write Cycle No. 3 (\overline{WE} Controlled, \overline{OE} LOW)

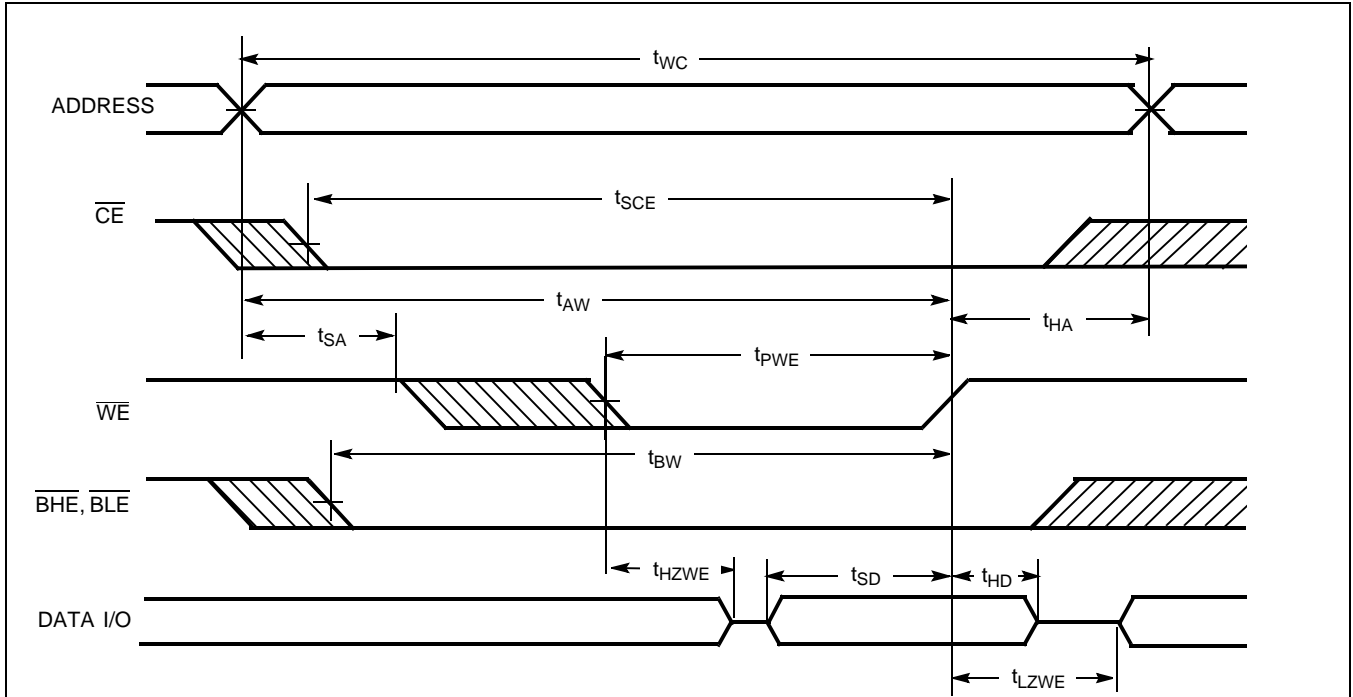

Truth Table

\overline{CE}	\overline{OE}	\overline{WE}	\overline{BLE}	\overline{BHE}	I/O ₀ -I/O ₇	I/O ₈ -I/O ₁₅	Mode	Power
H	X	X	X	X	High Z	High Z	Power Down	Standby (I_{SB})
L	L	H	L	L	Data Out	Data Out	Read All Bits	Active (I_{CC})
L	L	H	L	H	Data Out	High Z	Read Lower Bits Only	Active (I_{CC})
L	L	H	H	L	High Z	Data Out	Read Upper Bits Only	Active (I_{CC})
L	X	L	L	L	Data In	Data In	Write All Bits	Active (I_{CC})
L	X	L	L	H	Data In	High Z	Write Lower Bits Only	Active (I_{CC})
L	X	L	H	L	High Z	Data In	Write Upper Bits Only	Active (I_{CC})
L	H	H	X	X	High Z	High Z	Selected, Outputs Disabled	Active (I_{CC})

Ordering Information

Speed (ns)	Ordering Code	Package Diagram	Package Type	Operating Range
12	CY7C1041BNV33-12VXC	51-85082	44-Lead (400-Mil) Molded SOJ (Pb-free)	Commercial
	CY7C1041BNV33L-12VXC	51-85082	44-Lead (400-Mil) Molded SOJ (Pb-free)	
	CY7C1041BNV33L-12VC	51-85082	44-Lead (400-Mil) Molded SOJ	
	CY7C1041BNV33L-12ZC	51-85087	44-Pin TSOP II Z44	
	CY7C1041BNV33L-12ZXC	51-85087	44-Pin TSOP II Z44 (Pb-free)	
15	CY7C1041BNV33-15VXC	51-85082	44-Lead (400-Mil) Molded SOJ (Pb-free)	Commercial
	CY7C1041BNV33L-15VXC	51-85082	44-Lead (400-Mil) Molded SOJ (Pb-free)	
	CY7C1041BNV33L-15ZXC	51-85087	44-Pin TSOP II Z44 (Pb-free)	
	CY7C1041BNV33-15VXI	51-85082	44-Lead (400-Mil) Molded SOJ (Pb-free)	Industrial

Please contact local sales representative regarding availability of these parts.

Package Diagrams

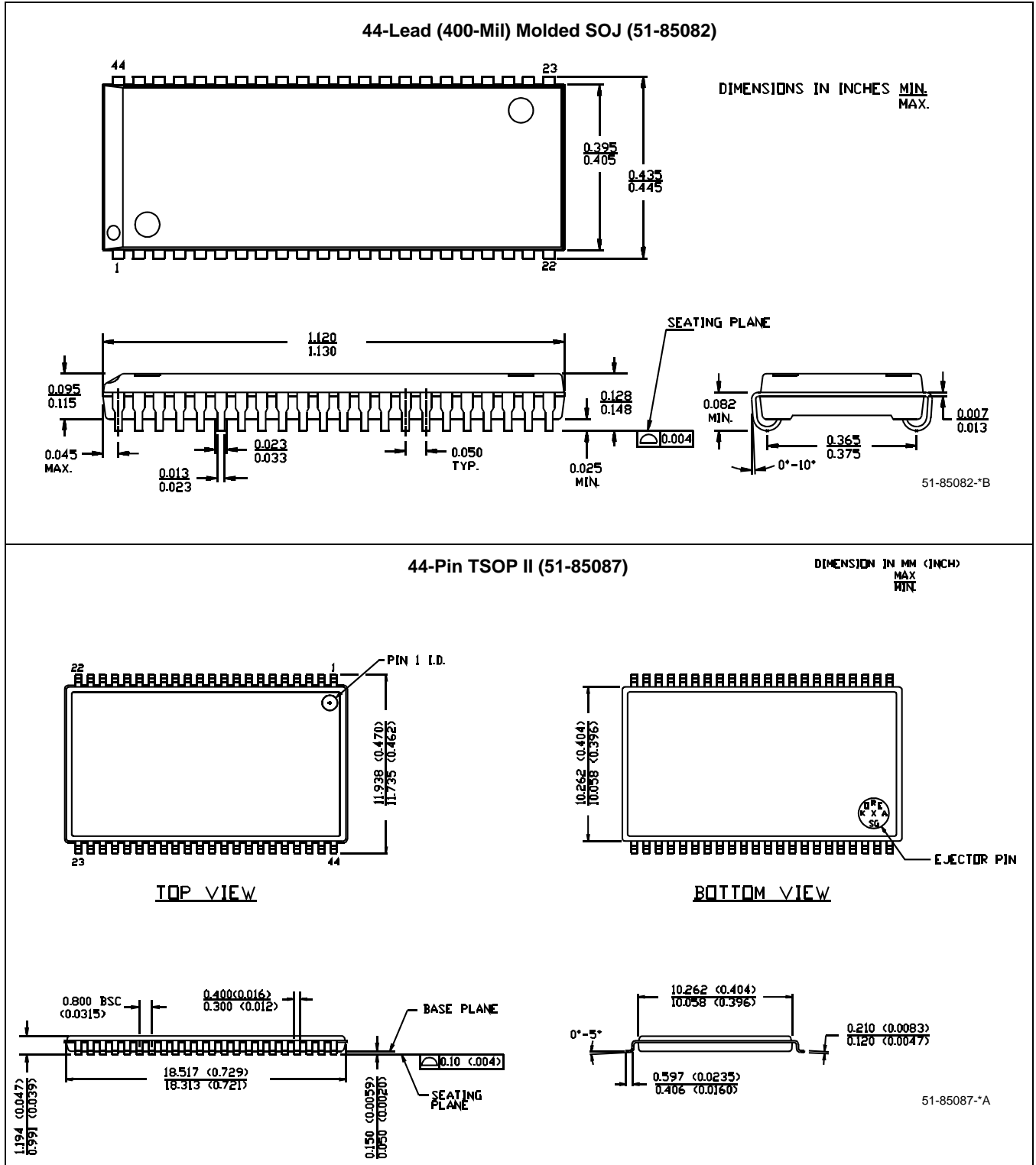

All product and company names mentioned in this document may be the trademarks of their respective holders.



Document History Page

Document Title: CY7C1041BNV33 256K x 16 Static RAM Document Number: 001-06434				
REV.	ECN NO.	Issue Date	Orig. of Change	Description of Change
**	423877	See ECN	NXR	New Data Sheet