



**40Pin Flash Disk Module Min.8MB ~ Max.1GB, True IDE Interface
Mode, 3.3V / 5.0V Operating**

Part No. HFDOM40MRxxx

1. PRODUCT OVERVIEW

GENERAL DESCRIPTION

The HFDOM40MRxxx series 40Pin Flash Disk Module is a flash technology based with True IDE interface flash memory card. It is constructed with flash disk controller chip and NAND-type (Samsung) flash memory device. The HFDOM40MRxxx series operates in both 3.3-Volt and 5.0-Volt power supplies. It comes in capacity of 16, 32, 64, 128, 192, 256, 512 MB and up to 1GB MB formatted 40Pin type .

By optimizing flash memory management, the life of this HFDOM40MRxxx series can be extended to its maximum level. Because the ECC function is included, the correctness of data transfer between the HFDOM40MRxxx series and a True IDE compatible interface device can be guaranteed.

The HFDOM40MRxxx series is fully compatible with applications such as CPU card / board, set top box, industry / military PC / Notebook, security equipment, measuring instrument and embedded systems.

FEATURES

- ATA / True IDE compatible host interface
- ATA command set compatible
- Automatic sensing of PC Card ATA or true IDE host interface.
- Very high performance, low power consumption
- Automatic error detection and error correction
- Auto Standby to save power consumption.
- Supports automatic power down and wake up
- Support for 8 or 16 bit host transfers
- 3.3V/5.0V operation voltage
- Host Interface bus width : 8/16 bit Access
- Flash Interface bus width : 8 bit Access
- Capacity : Min. 16MB ~ Max. 1GB

PRODUCT SPECIFICATIONS

Capacities :

16, 32, 48, 64, 96, 128, 192, 256, 512 and up to 1GB (formatted)

System Compatibility :

Please refer to the compatibility list of index.

Performance :

Host Data Transfer Rates : up to 16.6 MB/sec, PIO mode 4; 16.6MB/sec, Multi-word
DMA mode 2; 33MB/sec

Reliability :

MTBF	: xxx,xxx hours
ECC	: Embedded ECC Function
Data Retention	: 10 years

Operating Voltage : 3.3V / 5.0V \pm 10%

Power consumption : 3.3V \pm 5%

Read mode	<40 mA
Write mode	<60 mA
Stop mode	<2 mA

Environment conditions :

Operating temperature	0°C to + 65°C
Storage temperature	- °C to + °C
Relative humidity	8% to 95%, non-condensing

ELECTRICAL SPECIFICATIONS**Table 1.1 Absolute Maximum Ratings**

Symbol	Parameter	Rating	Units
V _{DD}	Power supply	-0.3 to 6.0	V
V _{IN}	Input voltage	-0.3 to V _{DD} +0.3	V
V _{OUT}	Output voltage	-0.3 to V _{DD} +0.3	V
T _{STG}	Storage temperature	-25 to 125	°C

Table 1.2 Recommended Operating Conditions

Symbol	Parameter	Min.	Max.	Units
V _{DD}	Power supply	3.0	5.5	V
V _{IN}	Input voltage	0	V _{DD}	V
T _{OPR}	Operating temperature	0	65	°C

Table 1.3 DC Characteristics

Sym.	Parameter	Min	Typ	Max	Units
V _{IL}	Input low voltage			0.6	V
V _{IH}	Input high voltage	2.4			V
V _{IL}	Schmitt input low voltage		1.0		V
V _{IH}	Schmitt input high voltage		1.8		V
V _{OL}	Output low voltage			0.4	V
V _{OH}	Output high voltage	2.5			V
R _I	Input pull up/down resistance	50			kΩ

CAPACITY SPECIFICATIONS

Table 1.4 Capacity Specifications

Part Number	Capacity (formatted)	Cylinders	Heads	Sectors	NOTE
HFDOM40MR032	32,24.3712 Mbytes	492	8	16	

INSTALLTION GUIDE

1) Setting Method

Make sure your computer is turned off before you open the case.

Plug the carefully into the 40pin IDE slot on your computer.

Caution: Make sure to align pin1 on host adapter interface connector with pin 1 on your Flash Disk Module. Pin 1 is indicated by a triangle on the Flash Disk Module connector.

The Flash Disk Module is used power connector cable of the computer.

Caution: If you need to remove your Flash Disk Module, use both hands to pull it out carefully.

Check all cable connections and then replace your computer cover.

2) BIOS setting Method

Before you format or partition your new drive, you must configure your computer's BIOS so that the computer can recognize your new drive.

Turn your computer on. As your computer start up, watch the screen for a message describing how to run the system setup program on the screen (sometimes called BIOS or CMOS setup). This is usually done by pressing a special key, such as **Delete**, **Esc** or **F1** during startup. See your computer manual for details. Press the appropriate key to run the system setup program.

If your BIOS provides automatic drive detection (an "AUTO" drive type), select this option. (We recommend to use Normal / CHS mode to partition your Flash Disk Module to get the maximum formatted capacity.)

This allows your computer to configure itself automatically for your new drive.

If your BIOS dose not provide "AUTO" drive detection, select "User-defined" drive setting and enter the CHS values from the table. BIOS Settings (see specification) Capacity Cylinders Heads Sectors(unformatted)

Save the settings and exit the System Setup program. (your computer will automatically reboot) After you configure your computer, you can use the standard DOS commands to partition and format your Flash Disk Module, as described below.

3) Formatting Method

To partition your new Flash Disk Module with Microsoft DOS program :

Insert a bootable DOS diskette into your diskette drive and restart your computer.

Insert a DOS program diskette that contains the **FDISK.EXE** and **FORMAT.COM** programs into your diskette drive. Use the same DOS version that is on your bootable diskette. At the **A:\ >** prompt, type "**FDISK**" and press **Enter**.

Select "**Create DOS partition or logical DOS drive**" by pressing **1**. Then press **Enter**.

Select "**Create primary DOS partition**" by pressing **1** again. Then press **Enter**.

Create your first drive partition. If you are creating a partition that will be used to boot your computer (drive C), make sure that the partition is marked active.

Create an extended partition and additional logical drives as necessary, until all the space on your new hard drive has been partitioned.

When the partitioning is complete, **FDISK** reboots your computer.

Caution: Make sure to use the correct drive letters so that you do not format a drive that already contains data.

At the **A:\ >** prompt, type "**format c:/s**", where **c** is the letter of your first new partition, Repeat the format process

for all the new partitions you have created.
After you format your drive, it is ready to use.

2. PIN INFORMATION

PIN ASSIGNMENTS AND PIN TYPE

Table 2.1 Pin Assignment and Pin type

Pin	Signal	Pin Type	Pin	Signal	Pin Type
1	/RESET	I	2	GND	Ground
3	D07	I/O	4	D08	I/O
5	D06	I/O	6	D09	I/O
7	D05	I/O	8	D10	I/O
9	D04	I/O	10	D11	I/O
11	D03	I/O	12	D12	I/O
13	D02	I/O	14	D13	I/O
15	D01	I/O	16	D14	I/O
17	D00	I/O	18	D15	I/O
19	GND	DC	20	Key Pin	--
21	INPACK	--	22	GND	Ground
23	/IOW	I	24	GND	Ground
25	/IOR	I	26	GND	Ground
27	IORDY	O	28	Reserved	--
29	REG	--	30	GND	Ground
31	IRQ	O	32	/IOIS16	O
33	A01	I	34	/PDIAG	I/O
35	A00	I	36	A02	I
37	/CS0	I	38	/CS1	I
39	/DASP	I/O	40	GND	Ground

Signal Descriptions

Table 2.2 Signal Descriptions

Signal Name	Dir.	Pin	Description
A[2:0]	I	33,35,36	In True IDE Mode only A[2:0] are used to select the one of eight registers in the Task File, the remaining address lines should be grounded by the host.
-PDIAG	I/O	34	This input / output is the Pass Diagnostic signal in the Master / Slave handshake protocol.
-DASP	I/O	39	In the True IDE Mode, this input/output is the Disk Active/Slave Present signal in the Master/Slave handshake protocol.
-CS0, -CS1	I	37,38	CS0 is the chip select for the task file registers while CS2 is used to select the Alternate Status Register and the Device Control Register.
D[15:00]	I/O	3,4,5,6, 7,8,9,10, 11,12,13, 14,15,16, 17,18	All Task File operations occur in byte mode on the low order bus D00-D07 while all data transfers are 16 bit using D00-D15.
GND	--	2,19,22, 24,26, 30,40,	Ground.
-IOR	I	25	This is an I/O Read strobe generated by the host.
-IOW	I	23	The I/O Write strobe pulse is used to clock I/O data on the Card Data bus into the Storage Card controller registers when the Storage Card is configured to use the I/O interface. The clocking will occur on the negative to positive edge of the signal (trailing edge).
IRQ	O	31	In True IDE Mode signal is the active high Interrupt Request to the host.
-RESET	I	1	This input pin is the active low hardware reset from the host.
IORDY	O	27	This output signal may be used as IORDY.
-IOIS16	O	32	This output signal is asserted low when this device is expecting a word data transfer cycle.

BLOCK DIAGRAM

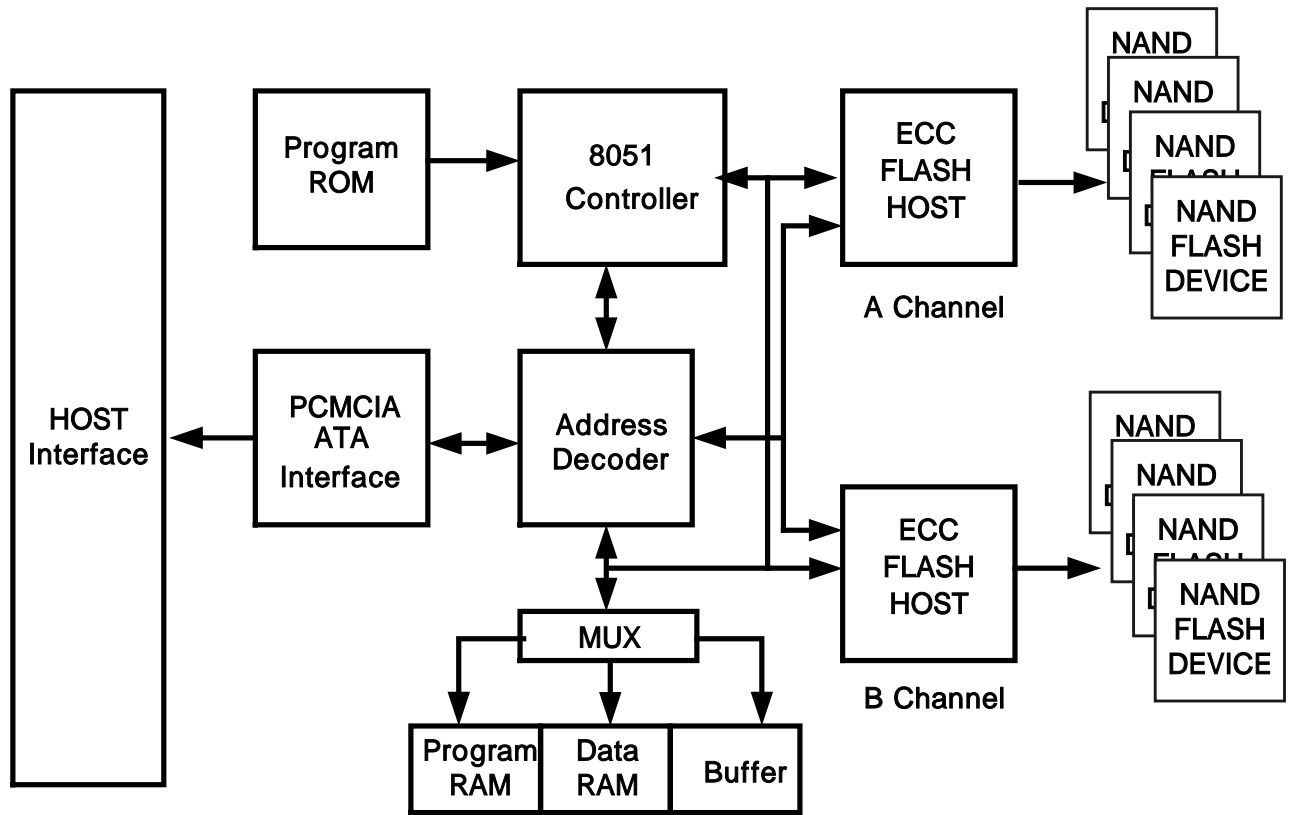

Figure 2.1 Block Diagram

REGISTERS

Overview

ATA register set definitions

- (1) . Error Register
- (2) . Device/Head Register
- (3) . Status & Alternate Status Register
- (4) . Device Control Register
- (5) . Card Address Register
- (6) . Data Register
- (7) . Feature Register
- (8) . Sector Count Register
- (9) . Sector Number Register
- (10) . Cylinder low register
- (11) . Cylinder high register

PCMCIA Register Set Definitions

- (1) . PCMCIA Configuration Option Register
- (2) . PCMCIA Configuration and Status Register
- (3) . PCMCIA pin Replacement Register
- (4) . PCMCIA Socket and Copy Register

ATA Register Set Definitions:

Error Register

This register contains additional information about the source of an error when an error is indicated in bit 0 of the Status register. The bits are defined as follows:

D7	D6	D5	D4	D3	D2	D1	D0
BBK	UNC	0	IDNF	0	ABRT	0	AMNF

This register is also accessed on data bits D15-D8 during a write operation to offset 0 with -CE2 low and -CE1 high.

Bit 7 (BBK): This bit is set when a Bad Block is detected.

Bit 6 (UNC): This bit is set when an Uncorrectable Error is encountered.

Bit 5: This bit is 0.

Bit 4 (IDNF): The requested sector ID is in error or cannot be found.

Bit 3: This bit is 0.

Bit 2 (Abort): This bit is set if the command has been aborted because of a CompactFlash Storage Card status condition: (Not Ready, Write Fault, etc.) or when an invalid command has been issued.

Bit 1 This bit is 0.

Bit 0 (AMNF) This bit is set in case of a general error.

Device/Head Register

The Drive/Head register is used to select the drive and head. It is also used to select LBA addressing instead of cylinder/head/sector addressing. The bits are defined as follows:

D7	D6	D5	D4	D3	D2	D1	D0
1	LBA	1	DRV	HS3	HS2	HS1	HS0

Bit 7: This bit is set to 1.

Bit 6: LBA is a flag to select either Cylinder/Head/Sector (CHS) or Logical Block Address Mode (LBA).

When LBA=0, Cylinder/Head/Sector mode is selected. When LBA=1, Logical Block Address is selected. In Logical Block Mode, the Logical Block Address is interpreted as follows:

LBA7-LBA0: Sector Number Register D7-D0.

LBA15-LBA8: Cylinder Low Register D7-D0.

LBA23-LBA16: Cylinder High Register D7-D0.

LBA27-LBA24: Drive/Head Register bits HS3-HS0.

Bit 5: This bit is set to 1.

Bit 4 (DRV): DRV is the drive number. When DRV=0, drive (card) 0 is selected. When DRV=1, drive (card) 1 is selected. The CompactFlash Storage Card is set to be Card 0 or 1 using the copy field (Drive #) of the PCMCIA Socket & Copy configuration register.

Bit 3 (HS3): When operating in the Cylinder, Head, Sector mode, this is bit 3 of the head number. It is Bit 27 in the Logical Block Address mode.

Bit 2 (HS2): When operating in the Cylinder, Head, Sector mode, this is bit 2 of the head number. It is Bit 26 in the Logical Block Address mode.

Bit 1 (HS1): When operating in the Cylinder, Head, Sector mode, this is bit 1 of the head number. It is Bit 25 in the Logical Block Address mode.

Bit 0 (HS0): When operating in the Cylinder, Head, Sector mode, this is bit 0 of the head number. It is Bit 24 in the Logical Block Address mode.

Status & Alternate Status Register

These registers return the CompactFlash Storage Card status when read by the host. Reading the Status register does clear a pending interrupt while reading the Auxiliary Status register does not. The status bits are described as follows:

D7	D6	D5	D4	D3	D2	D1	D0
BUSY	RDY	DWF	DSC	DRQ	CORR	0	ERR

Bit 7 (BUSY): The busy bit is set when the CompactFlash Storage Card has access to the command buffer

and registers and the host is locked out from accessing the command register and buffer. No other bits in this register are valid when this bit is set to a 1.

Bit 6 (RDY): RDY indicates whether the device is capable of performing CompactFlash Storage Card operations. This bit is cleared at power up and remains cleared until the CompactFlash Storage Card is ready to accept a command.

Bit 5 (DWF): This bit, if set, indicates a write fault has occurred.

Bit 4 (DSC): This bit is set when the CompactFlash Storage Card is ready.

Bit 3 (DRQ): The Data Request is set when the CompactFlash Storage Card requires that information be transferred either to or from the host through the Data register.

Bit 2 (CORR): This bit is set when a Correctable data error has been encountered and the data has been corrected. This condition does not terminate a multi-sector read operation.

Bit 1 (IDX): This bit is always set to 0.

Bit 0 (ERR): This bit is set when the previous command has terminated with some type of error. The bits in the Error register contain additional information describing the error. It is recommended that media access commands (such as Read Sectors and Write Sectors) that end with an error condition should have the address of the first sector in error in the command block registers.

Device Control Register

This register is used to control the CompactFlash Storage Card interrupt request and to issue an ATA soft reset to the card. This register can be written even if the device is BUSY. The bits are defined as follows:

D7	D6	D5	D4	D3	D2	D1	D0
X	X	X	X	1	SW Rst	-IEEn	0

Bit 7: This bit is an X (don't care).

Bit 6: This bit is an X (don't care).

Bit 5: This bit is an X (don't care).

Bit 4: This bit is an X (don't care).

Bit 3: This bit is ignored by the CompactFlash Storage Card.

Bit 2 (SW Rst): This bit is set to 1 in order to force the CompactFlash Storage Card to perform an AT Disk controller Soft Reset operation. This does not change the PCMCIA Card Configuration Registers (4.3.2 to 4.3.5) as a hardware Reset does. The Card remains Reset until this bit is reset to '0.'

Bit 1 (-IEEn): The Interrupt Enable bit enables interrupts when the bit is 0. When the bit is 1, interrupts from the CompactFlash Storage Card are disabled. This bit also controls the Int bit in the Configuration and Status Register. This bit is set to 0 at power on and Reset.

Bit 0: This bit is ignored by the CompactFlash Storage Card.

Card Address Register

This register is provided for compatibility with the AT disk drive interface. It is recommended that this register not be mapped into the host's I/O space because of potential conflicts on Bit 7. The bits are defined as follows:

D7	D6	D5	D4	D3	D2	D1	D0
X	-WTG	-HS3	-HS2	-HS1	-HS0	-nDS1	-nDS0

Bit 7: This bit is reserved.

Implementation Note:

Conflicts may occur on the host data bus when this bit is provided by a Floppy Disk Controller operating at the same addresses as the CompactFlash Storage Card. Following are some possible solutions to this problem for the PCMCIA implementation:

- 1) Locate the CompactFlash Storage Card at a non-conflicting address, i.e. Secondary address (377) or in an independently decoded Address Space when a Floppy Disk Controller is located at the Primary addresses.
- 2) Do not install a Floppy and a CompactFlash Storage Card in the system at the same time.
- 3) Implement a socket adapter which can be programmed to (conditionally) tri-state D7 of I/O address 3F7h/377h when a CompactFlash Storage Card is installed and conversely to tri-state D6-D0 of I/O addresses 3F7h/377h when a floppy controller is installed.
- 4) Do not use the CompactFlash Storage Card's Drive Address register. This may be accomplished by either a) If possible, program the host adapter to enable only I/O addresses 1F0h-1F7h, 3F6h (or 170h-177h, 176h) to the CompactFlash Storage Card or b) if provided use an additional Primary / Secondary configuration in the CompactFlash Storage Card which does not respond to accesses to I/O locations 3F7h and 377h. With either of these implementations, the host software must not attempt to use information in the Drive Address Register.

Bit 6 (-WTG): This bit is 0 when a write operation is in progress, otherwise, it is 1.

Bit 5 (-HS3): This bit is the negation of bit 3 in the Drive/Head register.

Bit 4 (-HS2): This bit is the negation of bit 2 in the Drive/Head register.

Bit 3 (-HS1): This bit is the negation of bit 1 in the Drive/Head register.

Bit 2 (-HS0): This bit is the negation of bit 0 in the Drive/Head register.

Bit 1 (-nDS1): This bit is 0 when drive 1 is active and selected.

Bit 0 (-nDS0): This bit is 0 when the drive 0 is active and selected.

Data Register

The Data Register is a 16-bit register, and it is used to transfer data blocks between the CompactFlash Storage Card data buffer and the Host. This register overlaps the Error Register. The table below describes the combinations of data register access and is provided to assist in understanding the overlapped Data Register and Error/Feature Register rather than to attempt to define general PCMCIA word and byte access modes and operations. See the PCMCIA PC Card Standard Release 2.0 for definitions of the Card Accessing Modes for I/O and Memory cycles.

15	14	13	12	11	10	9	8
Data (15:8)							

7	6	5	4	3	2	1	0
Data (7:0)							

Feature Register

This register provides information regarding features of the CompactFlash Storage Card that the host can utilize. This register is also accessed on data bits D15-D8 during a write operation to Offset 0 with -CE2 low and -CE1 high.

7	6	5	4	3	2	1	0
Command specific							

Sector Count Register

This register contains the numbers of sectors of data requested to be transferred on a read or write operation between the host and the CompactFlash Storage Card. If the value in this register is zero, a count of 256 sectors is specified. If the command was successful, this register is zero at command completion. If not successfully completed, the register contains the number of sectors that need to be transferred in order to complete the request.

7	6	5	4	3	2	1	0
Sector Count							

Sector Number Register

This register contains the starting sector number or bits 7-0 of the Logical Block Address (LBA) for any CompactFlash Storage Card data access for the subsequent command.

BIT DESCRIPTION -----

CHS							
7	6	5	4	3	2	1	0
Sector (7:0)							

LBA							
7	6	5	4	3	2	1	0
LBA (15:8)							

Cylinder Low Register

This register contains the low order 8 bits of the starting cylinder address or bits 15-8 of the Logical Block Address.

BIT DESCRIPTION-----

CHS							
7	6	5	4	3	2	1	0
Cylinder (7:0)							

LBA							
7	6	5	4	3	2	1	0
LBA (15:8)							

Cylinder High Register

This register contains the high order bits of the starting cylinder address or bits 23-16 of the Logical Block Address.

BIT DESCRIPTION -

CHS							
7	6	5	4	3	2	1	0
Cylinder (7:0)							

LBA							
7	6	5	4	3	2	1	0
LBA (15:8)							

3. INTERFACE BUS TIMING

ACCESS SPCIFICATIONS

True IDE Mode I/O Read Timing

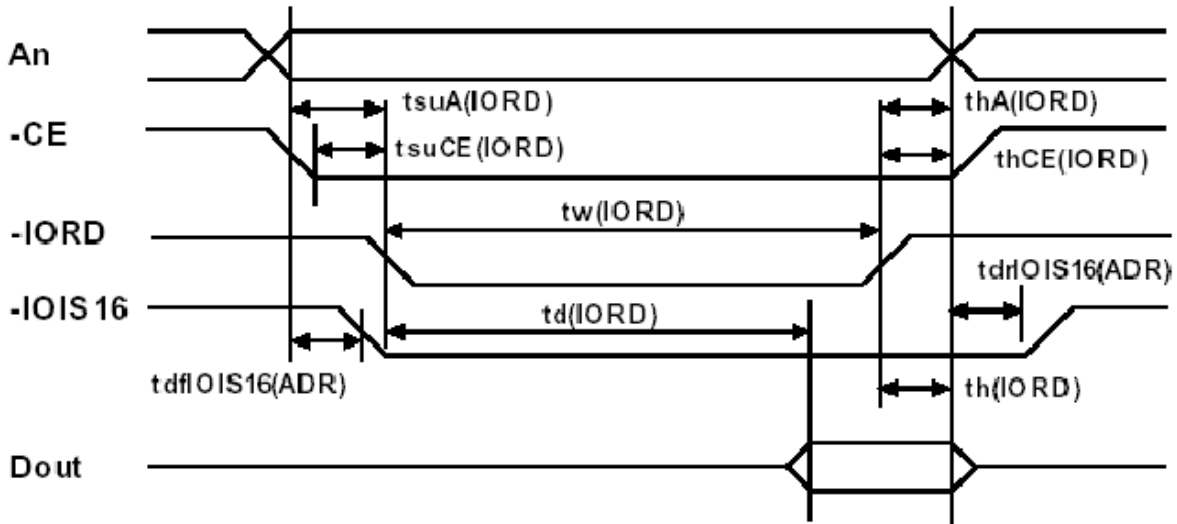

Table 3.1 True IDE Read Timing

Item	Symbol	Min	Max	Unit
Data Delay after \overline{IORD}	td(IORD)	-	100	ns
Data Hold following \overline{IORD}	th(IORD)	0	-	ns
\overline{IORD} Width Time	tw(IORD)	165	-	ns
Address Setup before \overline{IORD}	tsuA(IORD)	70	-	ns
Address Hold following \overline{IORD}	thA(IORD)	20	-	ns
\overline{CE} Setup before \overline{IORD}	tsuCE(IORD)	5	-	ns
\overline{CE} Hold following \overline{IORD}	thCE(IORD)	20	-	ns
$\overline{IOIS16}$ Delay Falling from Address	tdfIOIS16(ADR)	-	35	ns
$\overline{IOIS16}$ Delay Rising from Address	tdrIOIS16(ADR)	-	35	ns

True IDE Mode I/O Write Timing

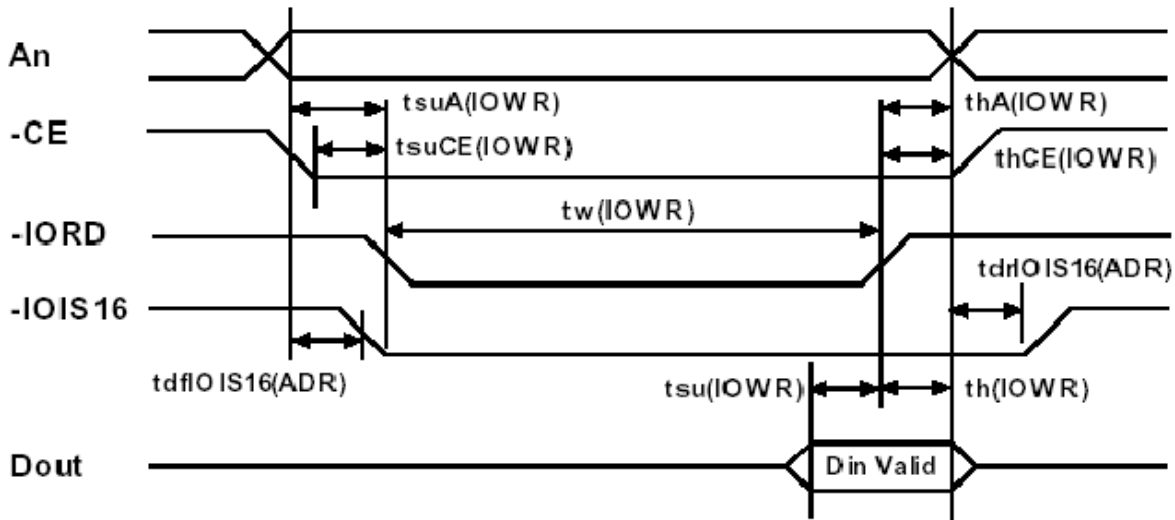

Table 3.2 True IDE Write Timing

Item	Symbol	Min	Max	Unit
Data Setup before \overline{IOWR}	$t_{su(IOWR)}$	60	-	ns
Data Hold following \overline{IOWR}	$t_{th(IOWR)}$	30	-	ns
\overline{IOWR} Width Time	$t_w(IOWR)$	165	-	ns
Address Setup before \overline{IOWR}	$t_{suA(IOWR)}$	70	-	ns
Address Hold following \overline{IOWR}	$t_{thA(IOWR)}$	20	-	ns
\overline{CE} Setup before \overline{IOWR}	$t_{suCE(IOWR)}$	5	-	ns
\overline{CE} Hold following \overline{IOWR}	$t_{thCE(IOWR)}$	20	-	ns
$\overline{IOIS16}$ Delay Falling from Address	$t_{dfIOIS16(ADR)}$	-	35	ns
$\overline{IOIS16}$ Delay Rising from Address	$t_{drIOIS16(ADR)}$	-	35	ns

Ordering Information

NO	Parts	Capacity	Media transfer mode	Chip Number	Operation Mode
1	DOM40MR016	16Mbyte	BYTE	1	True IDE
2	DOM40MR032	32Mbyte	BYTE	1	True IDE
3	DOM40MR064	64Mbyte	BYTE	1	True IDE
4	DOM40MR128	128Mbyte	BYTE	1	True IDE
5	DOM40MR256	256Mbyte	BYTE	1	True IDE
6	DOM40MR512	512Mbyte	BYTE	4	True IDE
7	DOM40MR16	1Gbyte	BYTE	4	True IDE
8	DOM40MR16	1Gbyte	BYTE	4	True IDE

PACKAGING

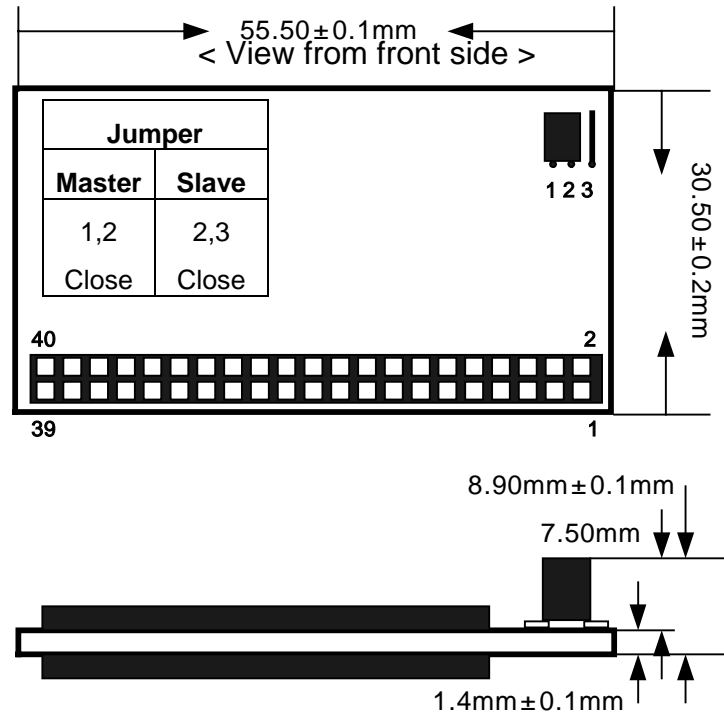

Figure 1.1 40 pin Type Flash Disk Module Dimensions

