

# MC10EP131, MC100EP131

## 3.3V / 5V ECL Quad D Flip-Flop with Set, Reset, and Differential Clock

The MC10/100EP131 is a Quad Master-slaved D flip-flop with common set and separate resets. The device is an expansion of the E131 with differential common clock and individual clock enables. With AC performance faster than the E131 device, the EP131 is ideal for applications requiring the fastest AC performance available.

Each flip-flop may be clocked separately by holding Common Clock ( $C_C$ ) LOW and  $\overline{C_C}$  HIGH, then using the differential Clock Enable inputs for clocking ( $C_{0-3}$ ,  $\overline{C_{0-3}}$ ).

Common clocking is achieved by holding the differential inputs  $C_{0-3}$  LOW and  $\overline{C_{0-3}}$  HIGH while using the differential Common Clock ( $C_C$ ) to clock all four flip-flops. When left floating open, any differential input will disable operation due to input pulldown resistors forcing an output default state.

Individual asynchronous resets ( $R_{0-3}$ ) and an asynchronous set (SET) are provided.

Data enters the master when both  $C_C$  and  $C_{0-3}$  are LOW, and transfers to the slave when either  $C_C$  or  $C_{0-3}$  (or both) go HIGH.

The 100 Series contains temperature compensation.

- 460 ps Typical Propagation Delay
- Maximum Frequency > 3 GHz Typical
- Differential Individual and Common Clocks
- Individual Asynchronous Resets
- Asynchronous Set
- PECL Mode Operating Range:  $V_{CC} = 3.0\text{ V}$  to  $5.5\text{ V}$  with  $V_{EE} = 0\text{ V}$
- NECL Mode Operating Range:  $V_{CC} = 0\text{ V}$  with  $V_{EE} = -3.0\text{ V}$  to  $-5.5\text{ V}$
- Open Input Default State
- Safety Clamp on Inputs
- Q Output Will Default LOW with Inputs Open or at  $V_{EE}$



ON Semiconductor®

<http://onsemi.com>

### MARKING DIAGRAM\*

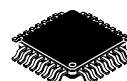

LQFP-32  
FA SUFFIX  
CASE 873A

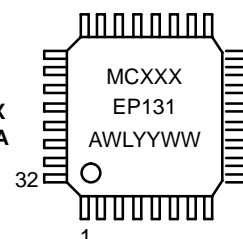

XXX = 10 or 100  
A = Assembly Location  
WL = Wafer Lot  
YY = Year  
WW = Work Week

\*For additional information, see Application Note AND8002/D

### ORDERING INFORMATION

Device	Package	Shipping
MC10EP131FA	LQFP-32	250 Units/Tray
MC10EP131FAR2	LQFP-32	2000 Tape & Reel
MC100EP131FA	LQFP-32	250 Units/Tray
MC100EP131FAR2	LQFP-32	2000 Tape & Reel

# MC10EP131, MC100EP131

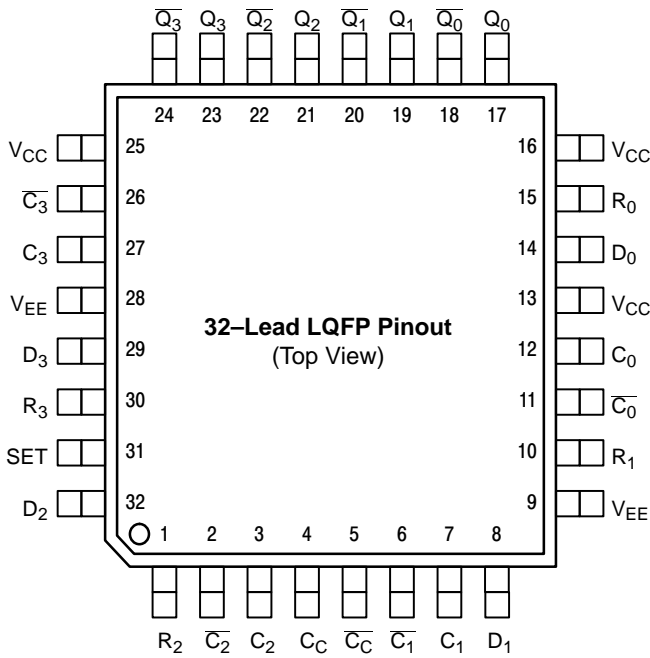

Warning: All V<sub>CC</sub> and V<sub>EE</sub> pins must be externally connected to Power Supply to guarantee proper operation.

Figure 1. 32-Lead LQFP Pinout (Top View)

### PIN DESCRIPTION

PIN	FUNCTION
D <sub>0-3</sub> *	ECL Data Inputs
C <sub>0-3</sub> *, $\overline{C}_{0-3}$ *	ECL Separate Clock Inputs
C <sub>C</sub> *, $\overline{C}_C$ *	ECL Common Clock Inputs
R <sub>0-3</sub> *	ECL Asynchronous Reset
SET*	ECL Asynchronous Set
Q <sub>0-3</sub> , $\overline{Q}_{0-3}$	ECL Data Outputs
V <sub>CC</sub>	Positive Supply
V <sub>EE</sub>	Negative Supply

\* Pins will default LOW when left open.

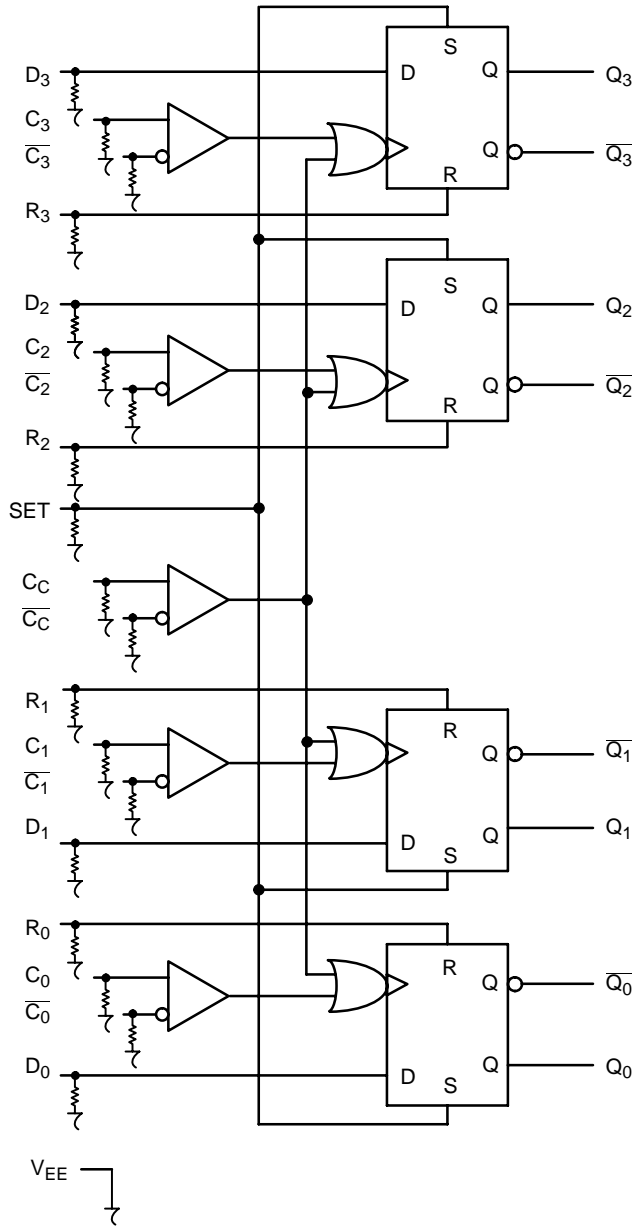

Figure 2. Logic Diagram

### ATTRIBUTES

Characteristics		Value
Internal Input Pulldown Resistor		75 kΩ
Internal Input Pullup Resistor		N/A
ESD Protection	Human Body Model	> 2 kV
	Machine Model	> 100 V
	Charged Device Model	> 2 kV
Moisture Sensitivity (Note 1)		Level 2
Flammability Rating Oxygen Index: 28 to 34		UL 94 V-0 @ 0.125 in
Transistor Count		935 Devices
Meets or exceeds JEDEC Spec EIA/JESD78 IC Latchup Test		

1. For additional information, see Application Note AND8003/D.

# MC10EP131, MC100EP131

## MAXIMUM RATINGS (Note 2)

Symbol	Parameter	Condition 1	Condition 2	Rating	Units
V <sub>CC</sub>	PECL Mode Power Supply	V <sub>EE</sub> = 0 V		6	V
V <sub>EE</sub>	NECL Mode Power Supply	V <sub>CC</sub> = 0 V		-6	V
V <sub>I</sub>	PECL Mode Input Voltage NECL Mode Input Voltage	V <sub>EE</sub> = 0 V V <sub>CC</sub> = 0 V	V <sub>I</sub> ≤ V <sub>CC</sub> V <sub>I</sub> ≥ V <sub>EE</sub>	6 -6	V V
I <sub>out</sub>	Output Current	Continuous Surge		50 100	mA mA
I <sub>BB</sub>	V <sub>BB</sub> Sink/Source			± 0.5	mA
T <sub>A</sub>	Operating Temperature Range			-40 to +85	°C
T <sub>stg</sub>	Storage Temperature Range			-65 to +150	°C
θ <sub>JA</sub>	Thermal Resistance (Junction-to-Ambient)	0 LFPM 500 LFPM	32 LQFP 32 LQFP	80 55	°C/W °C/W
θ <sub>JC</sub>	Thermal Resistance (Junction-to-Case)	std bd	32 LQFP	12 to 17	°C/W
T <sub>sol</sub>	Wave Solder	> 2 to 3 sec @ 248°C		265	°C

2. Maximum Ratings are those values beyond which device damage may occur.

## 10EP DC CHARACTERISTICS, PECL V<sub>CC</sub> = 3.3 V, V<sub>EE</sub> = 0 V (Note 3)

Symbol	Characteristic	-40°C			25°C			85°C			Unit
		Min	Typ	Max	Min	Typ	Max	Min	Typ	Max	
I <sub>EE</sub>	Power Supply Current	70	95	120	70	95	120	70	95	120	mA
V <sub>OH</sub>	Output HIGH Voltage (Note 4)	2165	2290	2415	2230	2355	2480	2290	2415	2540	mV
V <sub>OL</sub>	Output LOW Voltage (Note 4)	1365	1490	1615	1430	1555	1680	1490	1615	1740	mV
V <sub>IH</sub>	Input HIGH Voltage (Single-Ended)	2090		2415	2155		2480	2215		2540	mV
V <sub>IL</sub>	Input LOW Voltage (Single-Ended)	1365		1690	1460		1755	1490		1815	mV
V <sub>IHCMR</sub>	Input HIGH Voltage Common Mode Range (Differential) (Note 5)	2.0		3.3	2.0		3.3	2.0		3.3	V
I <sub>IH</sub>	Input HIGH Current			150			150			150	μA
I <sub>IL</sub>	Input LOW Current	0.5			0.5			0.5			μA

NOTE: EP circuits are designed to meet the DC specifications shown in the above table after thermal equilibrium has been established. The circuit is in a test socket or mounted on a printed circuit board and transverse airflow greater than 500 lfpm is maintained.

3. Input and output parameters vary 1:1 with V<sub>CC</sub>. V<sub>EE</sub> can vary +0.3 V to -2.2 V.

4. All loading with 50 Ω to V<sub>CC</sub>-2.0 volts.

5. V<sub>IHCMR</sub> min varies 1:1 with V<sub>EE</sub>, V<sub>IHCMR</sub> max varies 1:1 with V<sub>CC</sub>. The V<sub>IHCMR</sub> range is referenced to the most positive side of the differential input signal.

## 10EP DC CHARACTERISTICS, PECL V<sub>CC</sub> = 5.0 V, V<sub>EE</sub> = 0 V (Note 6)

Symbol	Characteristic	-40°C			25°C			85°C			Unit
		Min	Typ	Max	Min	Typ	Max	Min	Typ	Max	
I <sub>EE</sub>	Power Supply Current	70	95	120	70	95	120	70	95	120	mA
V <sub>OH</sub>	Output HIGH Voltage (Note 7)	3865	3990	4115	3930	4055	4180	3990	4115	4240	mV
V <sub>OL</sub>	Output LOW Voltage (Note 7)	3065	3190	3315	3130	3255	3380	3190	3315	3440	mV
V <sub>IH</sub>	Input HIGH Voltage (Single-Ended)	3790		4115	3855		4180	3915		4240	mV
V <sub>IL</sub>	Input LOW Voltage (Single-Ended)	3065		3390	3130		3455	3190		3515	mV
V <sub>IHCMR</sub>	Input HIGH Voltage Common Mode Range (Differential) (Note 8)	2.0		5.0	2.0		5.0	2.0		5.0	V
I <sub>IH</sub>	Input HIGH Current			150			150			150	μA
I <sub>IL</sub>	Input LOW Current	0.5			0.5			0.5			μA

NOTE: EP circuits are designed to meet the DC specifications shown in the above table after thermal equilibrium has been established. The circuit is in a test socket or mounted on a printed circuit board and transverse airflow greater than 500 lfpm is maintained.

6. Input and output parameters vary 1:1 with V<sub>CC</sub>. V<sub>EE</sub> can vary +2.0 V to -0.5 V.

7. All loading with 50 Ω to V<sub>CC</sub>-2.0 volts.

8. V<sub>IHCMR</sub> min varies 1:1 with V<sub>EE</sub>, V<sub>IHCMR</sub> max varies 1:1 with V<sub>CC</sub>. The V<sub>IHCMR</sub> range is referenced to the most positive side of the differential input signal.

# MC10EP131, MC100EP131

## 10EP DC CHARACTERISTICS, NECL $V_{CC} = 0\text{ V}$ , $V_{EE} = -5.5\text{ V}$ to $-3.0\text{ V}$ (Note 9)

Symbol	Characteristic	-40°C			25°C			85°C			Unit
		Min	Typ	Max	Min	Typ	Max	Min	Typ	Max	
$I_{EE}$	Power Supply Current	70	95	120	70	95	120	70	95	120	mA
$V_{OH}$	Output HIGH Voltage (Note 10)	-1135	-1010	-885	-1070	-945	-820	-1010	-885	-760	mV
$V_{OL}$	Output LOW Voltage (Note 10)	-1935	-1810	-1685	-1870	-1745	-1620	-1810	-1685	-1560	mV
$V_{IH}$	Input HIGH Voltage (Single-Ended)	-1210		-885	-1145		-820	-1085		-760	mV
$V_{IL}$	Input LOW Voltage (Single-Ended)	-1935		-1610	-1870		-1545	-1810		-1485	mV
$V_{IHCMR}$	Input HIGH Voltage Common Mode Range (Differential) (Note 11)	$V_{EE}+2.0$		0.0	$V_{EE}+2.0$		0.0	$V_{EE}+2.0$		0.0	V
$I_{IH}$	Input HIGH Current			150			150			150	$\mu\text{A}$
$I_{IL}$	Input LOW Current	0.5			0.5			0.5			$\mu\text{A}$

NOTE: EP circuits are designed to meet the DC specifications shown in the above table after thermal equilibrium has been established. The circuit is in a test socket or mounted on a printed circuit board and transverse airflow greater than 500 lfpm is maintained.

9. Input and output parameters vary 1:1 with  $V_{CC}$ .

10. All loading with  $50\ \Omega$  to  $V_{CC}-2.0$  volts.

11.  $V_{IHCMR}$  min varies 1:1 with  $V_{EE}$ ,  $V_{IHCMR}$  max varies 1:1 with  $V_{CC}$ . The  $V_{IHCMR}$  range is referenced to the most positive side of the differential input signal.

## 100EP DC CHARACTERISTICS, PECL $V_{CC} = 3.3\text{ V}$ , $V_{EE} = 0\text{ V}$ (Note 12)

Symbol	Characteristic	-40°C			25°C			85°C			Unit
		Min	Typ	Max	Min	Typ	Max	Min	Typ	Max	
$I_{EE}$	Power Supply Current	70	95	120	75	97	120	80	105	130	mA
$V_{OH}$	Output HIGH Voltage (Note 13)	2155	2280	2405	2155	2280	2405	2155	2280	2405	mV
$V_{OL}$	Output LOW Voltage (Note 13)	1355	1480	1605	1355	1480	1605	1355	1480	1605	mV
$V_{IH}$	Input HIGH Voltage (Single-Ended)	2075		2420	2075		2420	2075		2420	mV
$V_{IL}$	Input LOW Voltage (Single-Ended)	1355		1675	1355		1675	1355		1675	mV
$V_{IHCMR}$	Input HIGH Voltage Common Mode Range (Differential) (Note 14)	2.0		3.3	2.0		3.3	2.0		3.3	V
$I_{IH}$	Input HIGH Current			150			150			150	$\mu\text{A}$
$I_{IL}$	Input LOW Current	0.5			0.5			0.5			$\mu\text{A}$

NOTE: EP circuits are designed to meet the DC specifications shown in the above table after thermal equilibrium has been established. The circuit is in a test socket or mounted on a printed circuit board and transverse airflow greater than 500 lfpm is maintained.

12. Input and output parameters vary 1:1 with  $V_{CC}$ .  $V_{EE}$  can vary +0.3 V to -2.2 V.

13. All loading with  $50\ \Omega$  to  $V_{CC}-2.0$  volts.

14.  $V_{IHCMR}$  min varies 1:1 with  $V_{EE}$ ,  $V_{IHCMR}$  max varies 1:1 with  $V_{CC}$ . The  $V_{IHCMR}$  range is referenced to the most positive side of the differential input signal.

## 100EP DC CHARACTERISTICS, PECL $V_{CC} = 5.0\text{ V}$ , $V_{EE} = 0\text{ V}$ (Note 15)

Symbol	Characteristic	-40°C			25°C			85°C			Unit
		Min	Typ	Max	Min	Typ	Max	Min	Typ	Max	
$I_{EE}$	Power Supply Current	70	95	120	75	97	120	80	105	130	mA
$V_{OH}$	Output HIGH Voltage (Note 16)	3855	3980	4105	3855	3980	4105	3855	3980	4105	mV
$V_{OL}$	Output LOW Voltage (Note 16)	3055	3180	3305	3055	3180	3305	3055	3180	3305	mV
$V_{IH}$	Input HIGH Voltage (Single-Ended)	3775		4120	3775		4120	3775		4120	mV
$V_{IL}$	Input LOW Voltage (Single-Ended)	3055		3375	3055		3375	3055		3375	mV
$V_{IHCMR}$	Input HIGH Voltage Common Mode Range (Differential) (Note 17)	2.0		5.0	2.0		5.0	2.0		5.0	V
$I_{IH}$	Input HIGH Current			150			150			150	$\mu\text{A}$
$I_{IL}$	Input LOW Current	0.5			0.5			0.5			$\mu\text{A}$

NOTE: EP circuits are designed to meet the DC specifications shown in the above table after thermal equilibrium has been established. The circuit is in a test socket or mounted on a printed circuit board and transverse airflow greater than 500 lfpm is maintained.

15. Input and output parameters vary 1:1 with  $V_{CC}$ .  $V_{EE}$  can vary +2.0 V to -0.5 V.

16. All loading with  $50\ \Omega$  to  $V_{CC}-2.0$  volts.

17.  $V_{IHCMR}$  min varies 1:1 with  $V_{EE}$ ,  $V_{IHCMR}$  max varies 1:1 with  $V_{CC}$ . The  $V_{IHCMR}$  range is referenced to the most positive side of the differential input signal.

# MC10EP131, MC100EP131

## 100EP DC CHARACTERISTICS, NECL $V_{CC} = 0\text{ V}$ , $V_{EE} = -5.5\text{ V}$ to $-3.0\text{ V}$ (Note 18)

Symbol	Characteristic	-40°C			25°C			85°C			Unit
		Min	Typ	Max	Min	Typ	Max	Min	Typ	Max	
$I_{EE}$	Power Supply Current	70	95	120	75	97	120	80	105	130	mA
$V_{OH}$	Output HIGH Voltage (Note 19)	-1145	-1020	-895	-1145	-1020	-895	-1145	-1020	-895	mV
$V_{OL}$	Output LOW Voltage (Note 19)	-1945	-1820	-1695	-1945	-1820	-1695	-1945	-1820	-1695	mV
$V_{IH}$	Input HIGH Voltage (Single-Ended)	-1225		-880	-1225		-880	-1225		-880	mV
$V_{IL}$	Input LOW Voltage (Single-Ended)	-1945		-1625	-1945		-1625	-1945		-1625	mV
$V_{IHCMR}$	Input HIGH Voltage Common Mode Range (Differential) (Note 20)	$V_{EE}+2.0$		0.0	$V_{EE}+2.0$		0.0	$V_{EE}+2.0$		0.0	V
$I_{IH}$	Input HIGH Current			150			150			150	$\mu\text{A}$
$I_{IL}$	Input LOW Current	0.5			0.5			0.5			$\mu\text{A}$

NOTE: EP circuits are designed to meet the DC specifications shown in the above table after thermal equilibrium has been established. The circuit is in a test socket or mounted on a printed circuit board and transverse airflow greater than 500 lfpm is maintained.

18. Input and output parameters vary 1:1 with  $V_{CC}$ .

19. All loading with  $50\ \Omega$  to  $V_{CC}-2.0$  volts.

20.  $V_{IHCMR}$  min varies 1:1 with  $V_{EE}$ ,  $V_{IHCMR}$  max varies 1:1 with  $V_{CC}$ . The  $V_{IHCMR}$  range is referenced to the most positive side of the differential input signal.

## AC CHARACTERISTICS $V_{CC} = 0\text{ V}$ ; $V_{EE} = -3.0\text{ V}$ to $-5.5\text{ V}$ or $V_{CC} = 3.0\text{ V}$ to $5.5\text{ V}$ ; $V_{EE} = 0\text{ V}$ (Note 21)

Symbol	Characteristic	-40°C			25°C			85°C			Unit	
		Min	Typ	Max	Min	Typ	Max	Min	Typ	Max		
$f_{max}$	Maximum Frequency (See Figure 3. Frequency vs. $V_{OUTpp}$ and JITTER)		> 3			> 3			> 3		GHz	
$t_{PLH}$ , $t_{PHL}$	Propagation Delay to Output Differential	$C_{0-3}$ $C_C$ $R_{0-3}$ SET	320 320 320 300	450 450 430 430	520 520 520 550	380 400 380 380	460 500 480 460	580 600 580 580	450 450 450 400	560 560 560 530	650 650 700 650	ps
$t_{RR}$	Set/ $R_{0-3}$ Recovery		290	210		290	210		350	280		ps
$t_S$ $t_H$	Setup Time Hold Time		120	80		120	80		120	80		ps
$t_{PW}$	Minimum Pulse Rate SET, $R_{0-3}$		550	400		550	400		550	400		
$t_{JITTER}$	Cycle-to-Cycle Jitter (See Figure 3. Frequency vs. $V_{OUTpp}$ and JITTER)			0.2	< 1		0.2	< 1		0.2	< 1	ps
$t_r$ $t_f$	Output Rise/Fall Times (20% – 80%)	$Q$ , $\bar{Q}$	110	180	250	125	200	275	150	230	300	ps

21. Measured using a 750 mV source, 50% duty cycle clock source. All loading with  $50\ \Omega$  to  $V_{CC}-2.0\text{ V}$ .

## MC10EP131, MC100EP131

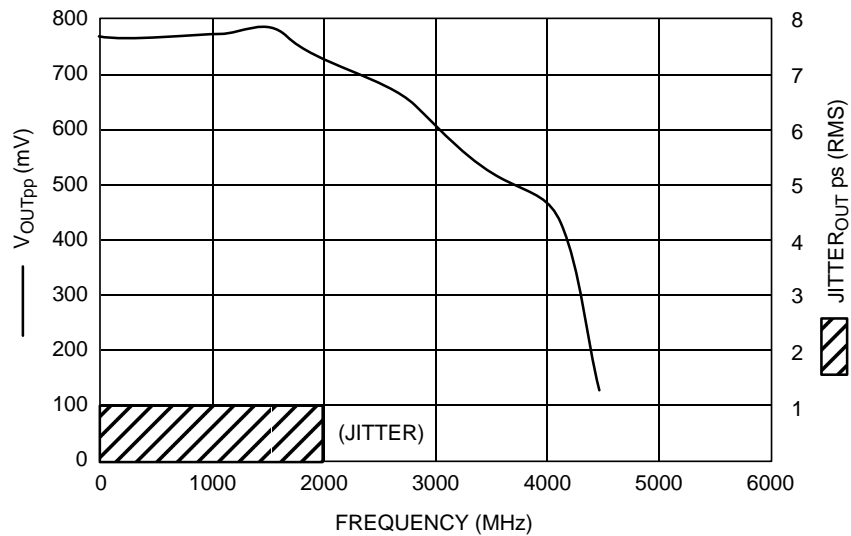

Figure 3. Frequency vs. V<sub>OUTpp</sub> and JITTER

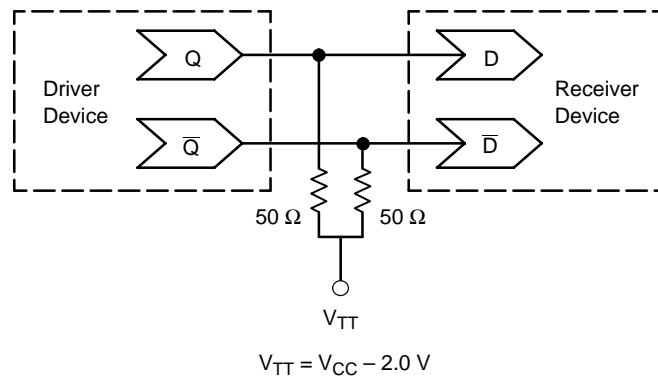

Figure 4. Typical Termination for Output Driver and Device Evaluation  
(See Application Note AND8020 – Termination of ECL Logic Devices.)

### Resource Reference of Application Notes

- AN1404** – ECLinPS Circuit Performance at Non–Standard V<sub>IH</sub> Levels
- AN1405** – ECL Clock Distribution Techniques
- AN1406** – Designing with PECL (ECL at +5.0 V)
- AN1504** – Metastability and the ECLinPS Family
- AN1568** – Interfacing Between LVDS and ECL
- AN1650** – Using Wire–OR Ties in ECLinPS Designs
- AN1672** – The ECL Translator Guide
- AND8001** – Odd Number Counters Design
- AND8002** – Marking and Date Codes
- AND8009** – ECLinPS Plus Spice I/O Model Kit
- AND8020** – Termination of ECL Logic Devices

For an updated list of Application Notes, please see our website at <http://onsemi.com>.

# MC10EP131, MC100EP131

## PACKAGE DIMENSIONS

LQFP  
FA SUFFIX  
32-LEAD PLASTIC PACKAGE  
CASE 873A-02  
ISSUE A

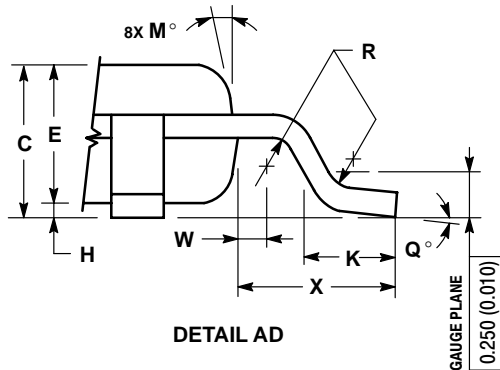
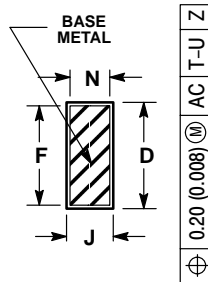
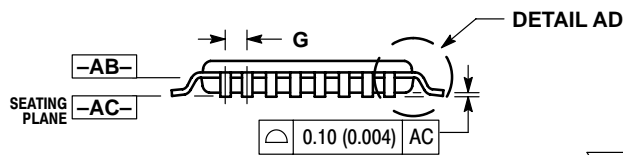
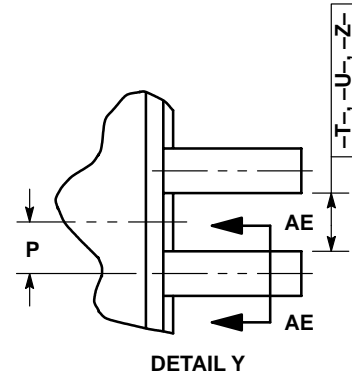
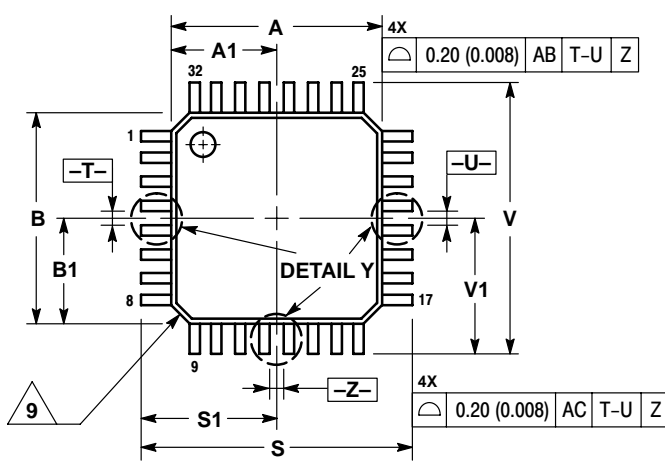

NOTES:

- DIMENSIONING AND TOLERANCING PER ANSI Y14.5M, 1982.
- CONTROLLING DIMENSION: MILLIMETER.
- DATUM PLANE -AB- IS LOCATED AT BOTTOM OF LEAD AND IS COINCIDENT WITH THE LEAD WHERE THE LEAD EXITS THE PLASTIC BODY AT THE BOTTOM OF THE PARTING LINE.
- DATUMS -T-, -U-, AND -Z- TO BE DETERMINED AT DATUM PLANE -AB-.
- DIMENSIONS S AND V TO BE DETERMINED AT SEATING PLANE -AC-.
- DIMENSIONS A AND B DO NOT INCLUDE MOLD PROTRUSION. ALLOWABLE PROTRUSION IS 0.250 (0.010) PER SIDE. DIMENSIONS A AND B DO INCLUDE MOLD MISMATCH AND ARE DETERMINED AT DATUM PLANE -AB-.
- DIMENSION D DOES NOT INCLUDE DAMBAR PROTRUSION. DAMBAR PROTRUSION SHALL NOT CAUSE THE D DIMENSION TO EXCEED 0.520 (0.020).
- MINIMUM SOLDER PLATE THICKNESS SHALL BE 0.0076 (0.0003).
- EXACT SHAPE OF EACH CORNER MAY VARY FROM DEPICTION.

DIM	MILLIMETERS		INCHES	
	MIN	MAX	MIN	MAX
A	7.000 BSC		0.276 BSC	
A1	3.500 BSC		0.138 BSC	
B	7.000 BSC		0.276 BSC	
B1	3.500 BSC		0.138 BSC	
C	1.400	1.600	0.055	0.063
D	0.300	0.450	0.012	0.018
E	1.350	1.450	0.053	0.057
F	0.300	0.400	0.012	0.016
G	0.800 BSC		0.031 BSC	
H	0.050	0.150	0.002	0.006
J	0.090	0.200	0.004	0.008
K	0.500	0.700	0.020	0.028
M	12° REF		12° REF	
N	0.090	0.160	0.004	0.006
P	0.400 BSC		0.016 BSC	
Q	1°	5°	1°	5°
R	0.150	0.250	0.006	0.010
S	9.000 BSC		0.354 BSC	
S1	4.500 BSC		0.177 BSC	
V	9.000 BSC		0.354 BSC	
V1	4.500 BSC		0.177 BSC	
W	0.200 REF		0.008 REF	
X	1.000 REF		0.039 REF	

# MC10EP131, MC100EP131

**ON Semiconductor** and  are registered trademarks of Semiconductor Components Industries, LLC (SCILLC). SCILLC reserves the right to make changes without further notice to any products herein. SCILLC makes no warranty, representation or guarantee regarding the suitability of its products for any particular purpose, nor does SCILLC assume any liability arising out of the application or use of any product or circuit, and specifically disclaims any and all liability, including without limitation special, consequential or incidental damages. "Typical" parameters which may be provided in SCILLC data sheets and/or specifications can and do vary in different applications and actual performance may vary over time. All operating parameters, including "Typicals" must be validated for each customer application by customer's technical experts. SCILLC does not convey any license under its patent rights nor the rights of others. SCILLC products are not designed, intended, or authorized for use as components in systems intended for surgical implant into the body, or other applications intended to support or sustain life, or for any other application in which the failure of the SCILLC product could create a situation where personal injury or death may occur. Should Buyer purchase or use SCILLC products for any such unintended or unauthorized application, Buyer shall indemnify and hold SCILLC and its officers, employees, subsidiaries, affiliates, and distributors harmless against all claims, costs, damages, and expenses, and reasonable attorney fees arising out of, directly or indirectly, any claim of personal injury or death associated with such unintended or unauthorized use, even if such claim alleges that SCILLC was negligent regarding the design or manufacture of the part. SCILLC is an Equal Opportunity/Affirmative Action Employer.

## PUBLICATION ORDERING INFORMATION

### Literature Fulfillment:

Literature Distribution Center for ON Semiconductor  
P.O. Box 5163, Denver, Colorado 80217 USA  
**Phone:** 303-675-2175 or 800-344-3860 Toll Free USA/Canada  
**Fax:** 303-675-2176 or 800-344-3867 Toll Free USA/Canada  
**Email:** ONlit@hibbertco.com

**N. American Technical Support:** 800-282-9855 Toll Free USA/Canada

**JAPAN:** ON Semiconductor, Japan Customer Focus Center  
4-32-1 Nishi-Gotanda, Shinagawa-ku, Tokyo, Japan 141-0031  
**Phone:** 81-3-5740-2700  
**Email:** r14525@onsemi.com

**ON Semiconductor Website:** <http://onsemi.com>

For additional information, please contact your local Sales Representative.