

# Dialight

## EXTERIOR STEPWELL LIGHT



Meets ADA requirement

### FEATURES / BENEFITS

- ▲ Low power consumption
- ▲ 10 - 30 Volts DC operation
- ▲ Wide angle uniform beam
- ▲ Long life
- ▲ Unique potted design
- ▲ Robust design
- ▲ Suitable for both indoor and outdoor applications
- ▲ Shatterproof lens
- ▲ Shock and vibration resistant
- ▲ Saves money - reduces maintenance cost

### APPLICATION

Dialight's Exterior Stepwell Light with white LED lamps offers a robust option suitable for interior and exterior stepwell illumination. The latest LED technology allows this light to meet the required ADA specification: illuminating a minimum of 1 foot candle in a 3'x3' area outside the stepwell. The vibration resistant design makes these devices ideal for use in rail, heavy-duty vehicle, and rugged industrial applications. The lamps potted construction provides a sealed operating environment for the LEDs and the integral wiring is readily adaptable to a wide variety of installations and applications.

### OPERATING CONDITIONS

- ▲ Operating Temperature: -40°C to +55°C
- ▲ Storage Temperature: -40°C to +120°C

### MATERIALS / FINISH

- ▲ Lens & housing Material: Polycarbonate

### PART NUMBERS

PART NUMBER	HOUSING COLOR	VOLTAGE
VSW-CC-19C-35-802	White	10-30 volts
VSW-CC-19B-35-801	Black	10-30 volts
VSW-CC-19M-35-803	Silver	10-30 volts

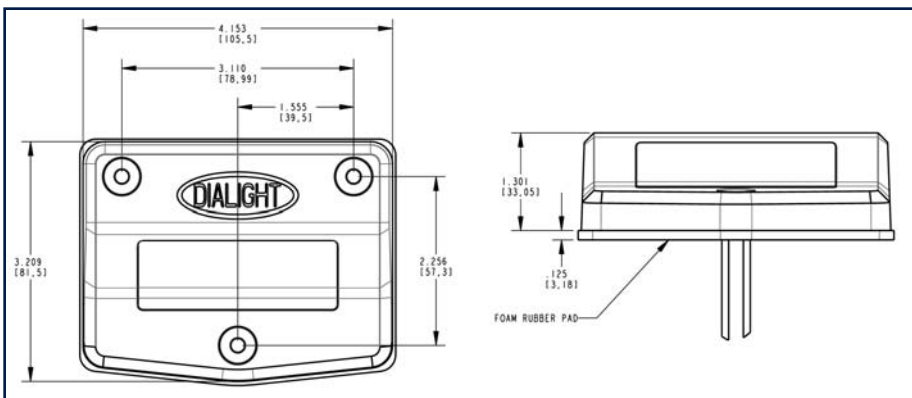

### Dialight Corporation

1501 Route 34 South • Farmingdale, NJ 07727 USA

Tel: (1) 732-919-3119 • Fax: (1) 732-751-5778 • www.dialight.com



MDTBSTPWL\_A