

Using the Xicor X5163/X5323/X5643 CPU Supervisors with the 68HC11 Microcontroller

by Applications Staff, September 1998

Description

The following code demonstrates how Xicor's CPU Supervisors with EEPROM can be interfaced to the 68HC11 microcontroller when connected as shown in Figure 1. The circuit uses the 68HC11's built-in SPI port with the PD4/SCK pin connected to the serial clock (SCK), the PD3/MOSI pin connected to serial data in (SI), the PD2/MISO pin connected to serial data out (SO), and the PD5/PCS0/CS pin connected to chip select (\overline{CS}). The SPI interface of the CPU Supervisors operate at 2MHz, so the

68HC11 can operate the SPI port at the maximum speed. This code allows the 68HC11 to read and write data from the EEPROM and select EEPROM Block Lock configurations. It also allows the 68HC11 to change the watchdog timer settings (if available) or turn off the watchdog timer.

More Information

Additional code can be found on the Xicor WWW site at <http://www.xicor.com>.

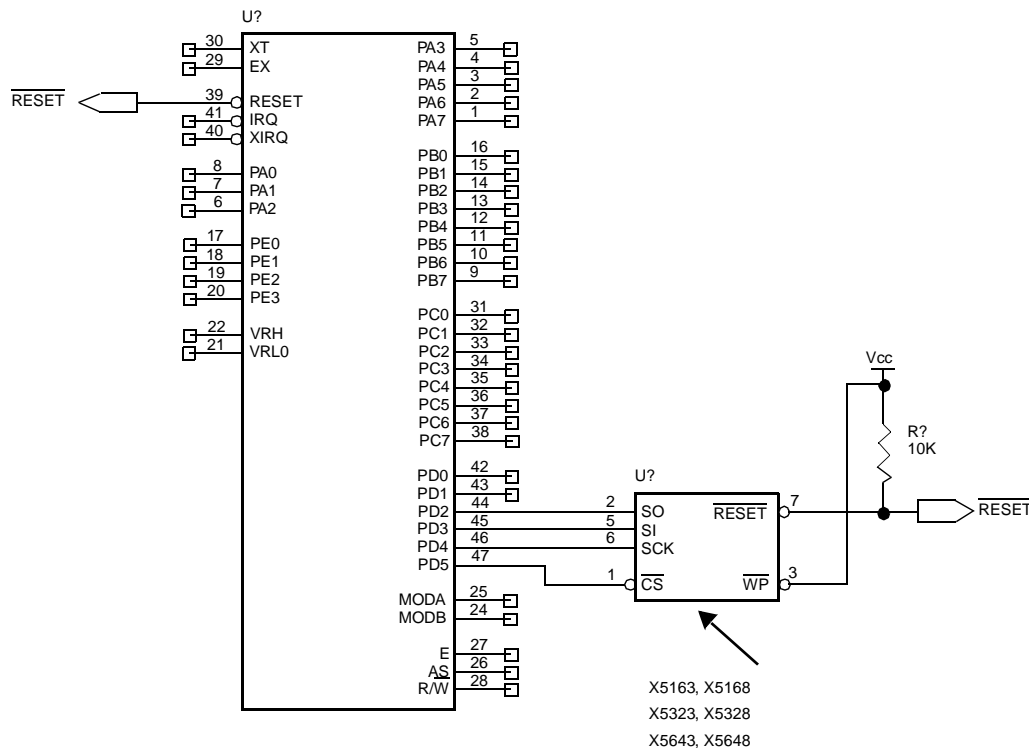

Figure 1. Interfacing the Xicor CPU Supervisors to the 68HC11 Microcontroller using the SPI Port

```

*****
** DESCRIPTION:
** The purpose of this program is to show the use of the M68HC11
** assembly language to program the XICOR CPU Supervisor device. The "WIP"
** status polling (ACKPOL program) is a unique feature of the SPI memories.
** The processor interfaces the EEPROM through its Serial Peripheral
** Interface Port (SPI). The SCK pin is connected to the serial clock (SCK),
** MOSI to serial data in(SI), MISO to the serial data out (SO), and PCS0/CS
** to the CS input of the EEPROM. The main section of the code calls up other
** modules in order to demonstrate the procedure to be followed when
** reading/writing from/to the device. Routines are provided that write and
** read data to/from the status register, including BlockLock and Watchdog
** Timer bits.
**
** This code supports the following supervisory products:
**
**         X5163, X5165, X5168, X5169*
**         X5323, X5325, X5328, X5329*
**         X5643, X5645, X5648, X5649*
**
** * These devices have no Watchdog Timer, so write '0' to the Wdx bits.
*****
* INTERNAL RAM LOCATIONS
ADDRL      EQU    $FF          MEMORY ADDRESS LOW BYTE
ADDRH      EQU    ADDR-1      MEMORY ADDRESS HIGH BYTE
PATTERN    EQU    ADDR-1      PATTERN REGISTER
STACK      EQU    PATTERN-1   STACK TOP
* CONSTANTS
WREN_CMD   EQU    006         WRITE ENABLE
WRITE_CMD  EQU    002         WRITE DATA TO EEPROM
READ_CMD   EQU    003         READ EEPROM DATA
WRDI_CMD   EQU    006         WRITE DISABLE
RDSR_CMD   EQU    005         READ STATUS REGISTER COMMAND
WRSR_CMD   EQU    001         WRITE STATUS REGISTER COMMAND
DUMMY      EQU    $FF        DUMMY STATUS OF MOSI PIN DURING BYTE READ
SPE_BIT    EQU    $40
SPIF_BIT   EQU    $80         BIT POSITION OF THE SPIF
CE_BIT     EQU    $20         BIT POSITION FOR PCS0/CS
* EQUATES FOR USE WITH INDEX OFFSET = $1000
PORTD      EQU    $08
DDR        EQU    $09
SPCR       EQU    $28
SPDR       EQU    $2A
SPSR       EQU    $29
BAUD       EQU    $2B
SCDAT      EQU    $2F
SCSR       EQU    $2E
SCCR2      EQU    $2D
STAT_BYTE  EQU    $00         Turn off BlockLock, Set WDT=1.4s
* ASSEMBLER REQUIREMENT- CPU TYPE
          P68H11
          PAGE
*      START OF USER CODE
          ORG    $E000
TEST:
          lds   #STACK        * LOAD STACK POINTER
          ldx   #$$1000       * SET REGISTER BASE
* INITIALIZE THE SPI
          ldaa  #$$3F
          staa DDRD,X         * PORT-D PINS ALL SET AS OUTPUTS
          ldaa  #$$50
          staa SPCR,X         * MODE = 0, CLK = 1MHZ
          ldaa  #$$00
          staa PATTERN       * DATA PATTERN TO WRITE

```

```

        ldy    #$100
        sty    ADDRH      * MEMORY ADDRESS TO WRITE
        tab                    * RECALL THE DATA PATTERN
        ldy    ADDRH      * LOAD THE MEMORY ADDRESS
        jsr    wr_byte     * WRITE THE BYTE
        jsr    ACK_POLL    * WAIT TILL DEVICE COMPLETS INTERNAL WRITE
        jsr    rd_byte     * READ THE BYTE
*
        ldab   #STAT_BYTE * GET THE STATUS BYTE
        jsr    wr_status   * WRITE THE STATUS
        jsr    ACK_POLL    * WAIT TILL DEVICE COMPLETS INTERNAL WRITE

        jmp    *
*****
*** Name: EE_WREN
*** Description: Enable write operation to the EEPROM
*** Function: This program sends out the command to enable the writes and
***           the store operations to the EEPROM
*** Calls: None
*** Input: None
*** Output: None
*** Register Usage: B
*****
EE_wren:
        bclr   PORTD,X,#CE_BIT    * ACTIVATE CE
        ldaa  #WREN_CMD          * WRITE ENABLE COMMAND
        jsr    outbyt            * OUTPUT THE COMMAND
        bset   PORTD,X,#CE_BIT    * DEACTIVATE CE
        rts

*****
*** Name: OUTBYT
*** Description: Sends a byte to the EEPROM
*** Function: This program shifts out a byte, MSB first to the EEPROM.
*** Calls: None
*** Input: A = Byte to be sent
*** Return Value: None
*** Register Usage: None
*****
outbyt:
        staa  SPDR,X

outbyt1:
        brclr SPSR,X,#SPIF_BIT,outbyt1 *WAIT FOR LAST ONE TO COMPLETE
        rts

*****
*** Name: RD_BYTE
*** Description: Reads content of the EEPROM at a specific location.
*** Function: This program sends out the command to read the content of a memory
***           location specified in the (E) register.
*** Calls: EE_read_cmd, outbyt
*** Input: Y = Address of the byte
*** Output: B = READ VALUE
*** Register Usage: B
*****
rd_byte:
        bclr   PORTD,X,#CE_BIT    * ACTIVATE CE
        jsr    EE_read_cmd        * ISSUE READ COMMAND
        pshy                    * SAVE ADDR
        tsy
        ldaa  0,y                * RECALL THE MSB OF ADDRESS
        jsr    outbyt            * SEND IT TO EEPROM
        ldaa  1,y                * RECALL THE LSB OF ADDRESS
        jsr    outbyt            * SEND IT TO EEPROM
        ldaa  #DUMMY             * SHIFT IN THE DATA FROM EEPROM
        jsr    outbyt
        ldaa  SPDR,X            * LOAD RECEIVED DATA FROM SPI
        bset   PORTD,X,#CE_BIT    * DEACTIVATE CE
        puly

```

```

        rts
*****
*** Name: EE_READ_CMD
*** Description: Sends the read command to the EEPROM
*** Function: This program sends a read command to the EEPROM
*** Calls: outbyt
*** Input: E = BYTE ADDRESS
*** Return Value: A = RECEIVED BYTE
*** Register Usage: B, E, IZ
*****
EE_read_cmd:
        ldaa    #READ_CMD          * SEND READ COMMAND TO THE EEPROM
        jmp     outbyt             * SEND THE COMMAND
*****
*** Name: WR_BYTE
*** Description: Writes a byte to the EEPROM at a specific location.
*** Function: This program writes the byte in the (B) register to the EEPROM
***             location specified by the (E) register.
*** Calls: EE_wren, EE_write_cmd, outbyt
*** Input: Y = byte Address, B = Data to write
*** Output: None
*** Register Usage: A,B
*****
wr_byte:
        jsr     EE_wren             * SEND WRITE ENABLE COMMAND
        bclr   PORTD,X,#CE_BIT     * ACTIVATE CE
        jsr     EE_write_cmd        * ISSUE WRITE COMMAND
        pshy                    * SAVE ADDR
        tsy
        ldaa   0,y                 * RECALL THE MSB OF ADDRESS
        jsr   outbyt               * SEND IT TO EEPROM
        ldaa   1,y                 * RECALL THE LSB OF ADDRESS
        jsr   outbyt               * SEND IT TO EEPROM
        tba
        jsr   outbyt               * SEND IT TO EEPROM
        bset   PORTD,X,#CE_BIT     * DEACTIVATE CE
        puly                    * RECALL ADDR
        rts
*****
*** Name: EE_write_cmd
*** Description: Sends the write command to the EEPROM
*** Function: This program creates the write command sequence and transmits
***             it to the EEPROM.
*** Calls: outbyt
*** Input: Y = BYTE ADDRESS
*** Return Value: None
*** Register Usage: A
*****
EE_write_cmd:
        ldaa   #WRITE_CMD         * SEND WRITE COMMAND TO THE EEPROM
        jmp   outbyt
*****
*** Name: WR_STATUS
*** Description: Writes a byte to the CPU Supervisor status register.
*** Function: This program writes the byte in the (B) register to the status
*** register. Since the command determines the address, no address is sent.
*** The data sent controls the operation of the BlockLock, InCircuit
*** Programmable ROM and Watchdog Timer Functions (if available). The content
*** of the byte sent is:
***
***
***             MSB                                     LSB
***             WPEN  X  WD1  WD0  BL1  BL0  WEL  WIP
***
*** Calls: EE_wren, EE_wrsr_cmd, outbyt
*** Input: Y = byte Address, B = Data to write
*** Output: None

```

```
*** Register Usage: A,B
```

```
*****
```

```
wr_status:
```

```
    jsr    EE_wren          * SEND WRITE ENABLE COMMAND
    bclr   PORTD,X,#CE_BIT  * ACTIVATE CE
    jsr    EE_wrsr_cmd      * ISSUE WRITE STATUS COMMAND
    tba                    * GET THE STATUS BYTE
    jsr    outbyt           * SEND IT TO EEPROM
    bset   PORTD,X,#CE_BIT  * DEACTIVATE CE
    rts
```

```
*****
```

```
*** Name: EE_wrsr_cmd
```

```
*** Description: Sends the write command to the EEPROM
```

```
*** Function: This program creates the write command sequence and transmits
***           it to the EEPROM.
```

```
*** Calls: outbyt
```

```
*** Input: Y = BYTE ADDRESS
```

```
*** Return Value: None
```

```
*** Register Usage: A
```

```
*****
```

```
EE_wrsr_cmd:
```

```
    ldaa   #WRSR_CMD        * SEND WRITE COMMAND TO THE EEPROM
    jmp    outbyt
```

```
*****
```

```
*** Name: ACK_POLL
```

```
*** Description: Verifies if the EEPROM is ready and accepting commands
```

```
*** Function: This program sends the status register read command to the
```

```
***           EEPROM and returns to the caller when the WIP bit in the status
***           byte is cleared or the maximum number of retries is reached.
```

```
***           This routine can also be used to read the status of the WdX and
```

```
***           BLx bits.
```

```
*** Calls: outbyt
```

```
*** Input: None
```

```
*** Return Value: None
```

```
*** Register Usage: A,B
```

```
*****
```

```
ACK_POLL:
```

```
ackpoll:
```

```
    bclr   PORTD,X,#CE_BIT  * ACTIVATE CE
    ldaa   #RDSR_CMD        * READ STATUS COMMAND
    jsr    outbyt           * SEND THE COMMAND
    ldaa   #DUMMY           * DUMMY COMMAND
    jsr    outbyt           * SEND THE COMMAND
    bset   PORTD,X,#CE_BIT  * DEACTIVATE CE
    ldaa   SPDR,X           * LOAD RECEIVED DATA FROM SPI
    asra
    bcc    ackpoll1
    rts
```

```
    ORG $FFFE
```

```
FDB TEST
```

```
END
```