



**PHOTOELECTRIC SMOKE DETECTOR
WITH INTERCONNECT**

GENERAL DESCRIPTION

The M75012 is a very low-power IC providing all of the required features for a photoelectric type smoke detector. This device can be used in conjunction with an infrared photoelectric chamber to sense scattered light from smoke particles.

A variable-gain photo amplifier can be directly interfaced to an infrared emitter / detector pair. The amplifier gain levels are determined by two external capacitors that are then internally selected depending on the operating mode. Low gain is selected during standby and timer modes. During a local alarm this low gain is increased (internally) by ~ 10% to reduce false triggering. High gain is used during the push-button test and during standby to periodically monitor the chamber sensitivity.

FEATURES

- Interconnect up to 50 detectors.
- Piezoelectric horn driver.
- Power-on reset.
- Built-in circuits to reduce false triggering.
- 6V to 12V operating voltage range.
- ESD-Protection circuitry on all pins.
- Temporal horn pattern.

APPLICATIONS

- Smoke detector.

PIN ASSIGNMENT

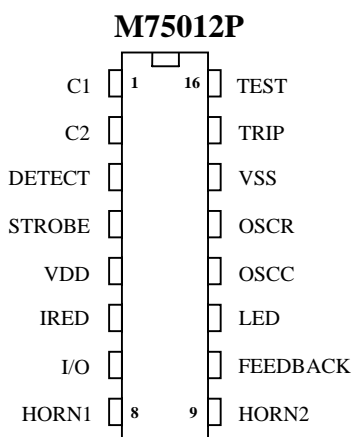



**PHOTOELECTRIC SMOKE DETECTOR
WITH INTERCONNECT**

M75012

ABSOLUTE MAXIMUM RATING

Parameter	Sym.	Rating	Unit
Supply Voltage Range	V_{DD}	-0.5 ~ 13	V
Input Voltage Range	V_{IN}	-0.3 to $V_{DD} + 0.3$	V
Input Current	I_{IN}	10	mA
Operating Temperature Range	T_A	-25 ~ 75	°C
Storage Temperature Range	T_S	-55 to 125	°C

PIN AND CIRCUIT DESCRIPTION

Pin No	Pin Name	Description
1	C1	A capacitor connected to this pin determines the gain of the photo amplifier during the push-to-test mode and during the chamber monitor test. A typical value for this high-gain mode is 0.047 μ F but should be selected based on the photo chamber background reflections reaching the detector and the desired level of sensitivity. $Ae \cong 1 + (C1 / 10)$ where C1 is in pF. Ae should not exceed 10,000.
2	C2	A capacitor connected to this pin determines the gain of the photo amplifier during standby. A typical value for this low-gain mode is 4700 pF but should be selected based on a specific photo chamber and the desired level of sensitivity to smoke. $Ae \cong 1 + (C2 / 10)$ where C2 is in pF. Ae should not exceed 10,000.
3	DETECT	This is the input to the photo amplifier and is connected to the cathode of the photo diode. The photo diode is operated at zero bias and should have low darkleakage current and low capacitance.
4	STROBE	This output provides a strobed , regulated voltage of VDD-5V. The minus side of all internal and external photo amplifier circuitry is referenced to this pin.
5	VDD	This pin is connected to the most-positive supply potential and can range from 6V to 12V with respect to VSS.
6	IRED	This output provides a pulsed base current for the external NPN transistor , which drives the IR emitter. Its beta should be greater than 100. The IRED output is not active , to minimize noise impact , when the horn and visible LED outputs are active.
7	I/O	A connection at this pin allows multiple smoke detectors to be interconnected. If a local smoke condition occurs , this pin is driven high. As an input , this pin is sampled nominally every 1.35 seconds during standby. Any local-alarm condition causes this pin to be ignored as an input. An internal NMOS device acts as a charge dump to aid in applications involving a large (distributed) capacitance. The charge dump is activated at the end of local or test alarm. This pin also has an on-chip pull-down resistor and must be left unconnected if not used. In application , there is a series current-limiting resistor to other smoke alarms.
8	HORN1	These three pins are used in conjunction with external passive components and a self-resonating piezoelectric transducer. HORN1 is connected to the piezo metal support electrode ; the complementary output , HORN2 , is connected to the ceramic electrode and the FEEDBACK input to the feedback electrode.
9	HORN2	
10	FEEDBACK	A continuous modulated tone indicates either a local or remote alarm condition. A short (10ms) chirp indicates a low-battery chirp occurs almost simultaneous with the visible LED flash. If the FEEDBACK pin is not used , it must be connected to VDD or VSS.



**PHOTOELECTRIC SMOKE DETECTOR
WITH INTERCONNECT**

11	LED	<p>This open-drain NMOS output is used to directly drive a visible LED. The low-battery test does not occur coincident with any other test or alarm signal. The LED also indicates detector status as follows (with component values as in the typical application , all times nominal) :</p> <p>Standby — Pulses every 43 seconds.</p> <p>Local Smoke — Pulses every 0.67 seconds.</p> <p>Remote Alarm — No pulses.</p> <p>Test Mode — Pulses every 0.67 seconds.</p>
12	OSCC	<p>A capacitor between this pin and VDD, along with a parallel resistor , forms part of a two-terminal oscillator and sets the internal clock low time. With component values as shown , this nominal time is 11 ms and essentially the oscillator period.</p>
13	OSCR	<p>A resistor between this pin and OSCC (pin 12) is part of the two-terminal oscillator and sets the internal clock high time , which is also the I_{RED} pulse width. With component values as shown , this nominal time is 105 μs .</p>
14	VSS	<p>This pin is connected to the most negative supply potential (usually ground).</p>
15	TRIP	<p>This pin is connected to an external voltage which determines the low-supply alarm threshold. The trip voltage is obtained through a resistor divider connected between the VDD and LED pins. The low-supply alarm threshold voltage (in volts) $\cong (5R15/R14) + 5$ where R15 and R14 are in the same units.</p>
16	TEST	<p>This pin has an internal pull-down device and is used to manually invoke a test mode. The Push-to-Test Mode is initiated by a high logic level on this pin (usually the depression of a normally open push-button switch to VDD). After one oscillator cycle, I_{RED} pulse every 336 ms (nominal) and amplifier gain is increased by internal selection of C1. Background reflections in the smoke chamber can be used to simulate a smoke condition. After the third I_{RED} pulse , a successful test (three consecutive simulated smoke conditions) activates the horn drivers and the I/O pin. When the push-button is released , the input returns to VSS due to the internal pull down. After one oscillator cycle , the amplifier gain returns to normal and after three additional I_{RED} pulse (less than one second) , the device exits this mode and returns to standby.</p>



PHOTOELECTRIC SMOKE DETECTOR
WITH INTERCONNECT

LOCAL ALARM TIMING DIAGRAM (NOT TO SCALE) :

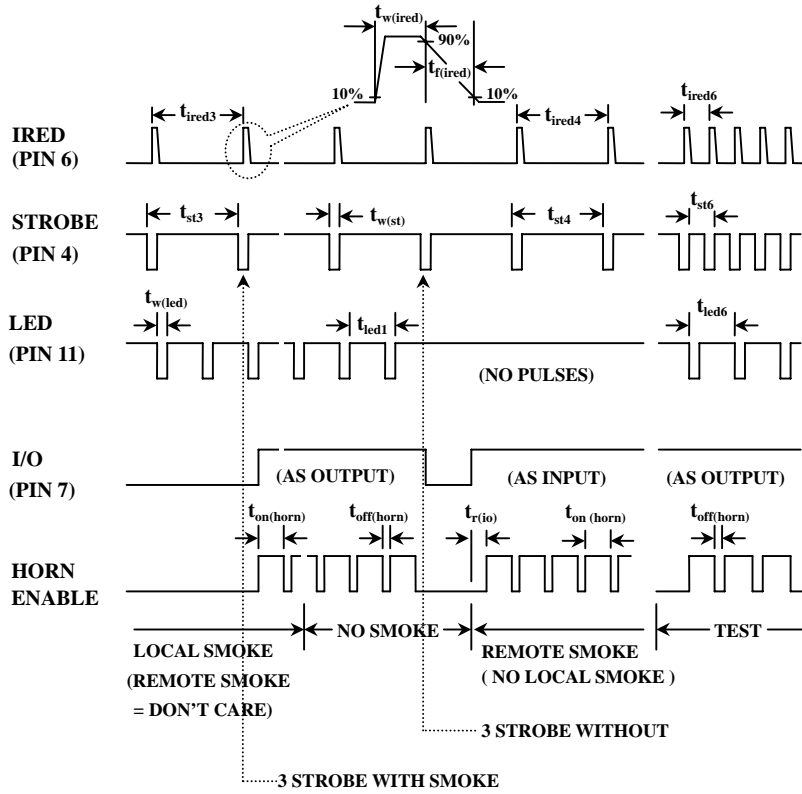



**PHOTOELECTRIC SMOKE DETECTOR
WITH INTERCONNECT**

STANDBY TIMING DIAGRAM (NOT TO SCALE) :

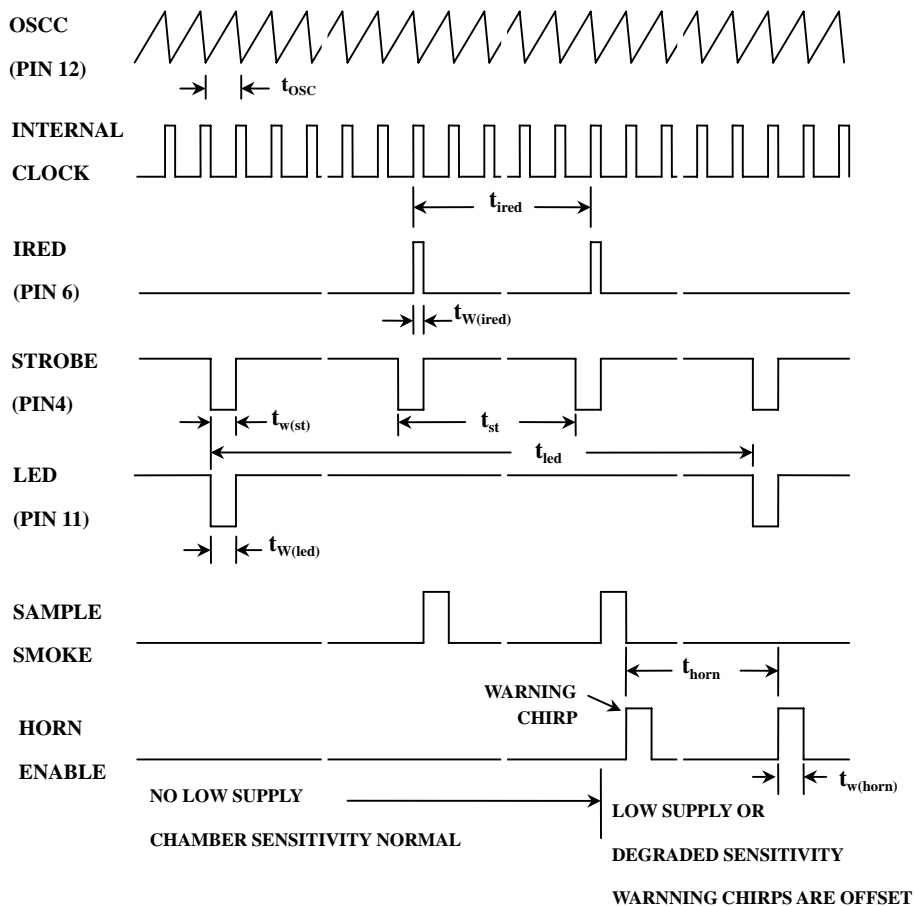



**PHOTOELECTRIC SMOKE DETECTOR
WITH INTERCONNECT**

FUNCTIONAL BLOCK DIAGRAM

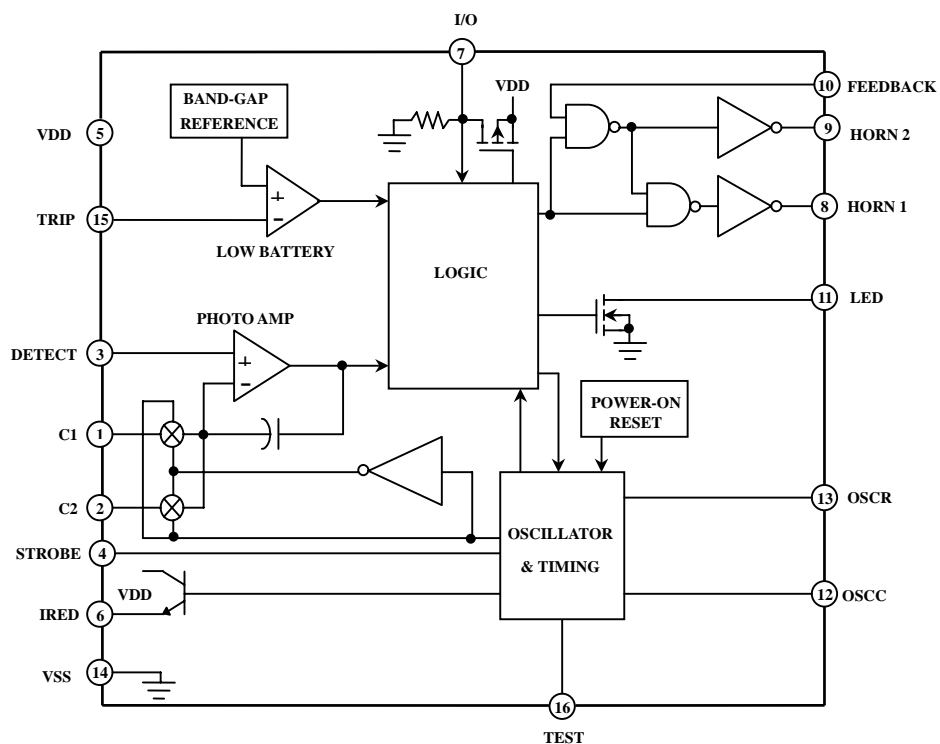



**PHOTOELECTRIC SMOKE DETECTOR
WITH INTERCONNECT**

DC ELECTRICAL CHARACTERISTICS

(TA=-25°C ~ 75°C)

Characteristics	Sym.	Pin	V _{DD}	Min.	Typ.	Max.	Unit	Conditions
Supply Voltage	V _{DD}		—	6.0	—	12	V	
Operating Supply Current	I _{DD}		12	—	—	12	μA	Average Standby
			12	—	—	2.0	mA	During Strobe ON, I _{RED} OFF
			12	—	—	3.0	mA	During Strobe ON, I _{RED} ON
Low-Level Input Voltage	V _{IL}	7	9	—	—	1.5	V	
		10	9	—	—	2.7	V	
		16	9	—	—	7.0	V	
		15	9	—	—	0.5	V	
High-Level Input Voltage	V _{IH}	7	9	3.2	—	—	V	
		10	9	6.3	—	—	V	
		16	9	8.5	—	—	V	
		15	9	1.6	—	—	V	
Input Leakage High	I _{IH}	12	12	—	—	100	nA	V _{IN} =V _{DD} , Strobe Active, Pin12 @V _{DD}
		15	12	—	—	100	nA	V _{IN} =V _{DD}
Input Leakage Low	I _{IL}	12	12	—	—	-100	nA	V _{IN} =V _{ST} , Strobe Active, Pin12 @V _{DD}
		15	12	—	—	-100	nA	
		16	12	—	—	-1.0	μA	
Input Pull-Down Current	I _{IN}	16	9	0.25	—	10	μA	V _{IN} =V _{DD} (@ V _{DD} =9V)
		7	9	20	—	80	μA	No Local Smoke, V _{IN} =V _{DD} (@V _{DD} =9V)
		7	12	—	—	140	μA	No Local Smoke, V _{IN} =17V (@V _{DD} =12V)
Low-Level Output Voltage	V _{OL}	11	6.5	—	—	0.6	V	I _O = 10mA
		8, 9	6.5	—	—	1.0	V	I _O = 16mA
		13	6.5	—	0.5	—	V	I _O = 5mA
High-Level Output Voltage	V _{OH}	8, 9	6.5	5.5	—	—	V	I _O = -16mA
Strobe Output Voltage	V _{ST}	4	12	V _{DD} -0.1	—	—	V	Inactive, I _O = -1 μA
			9	V _{DD} -5.6	—	V _{DD} -4.4	V	Active, I _O = 100 μA to 500 μA
Line Regulation	ΔV _{ST(ΔVDD)}		—	—	-60	—	dB	Active, V _{DD} =6V to 12V
I _{RED} Output Voltage	V _{IRED}	6	12	—	—	0.1	V	Inactive, I _O =1Ma, T _A = +25°C
			9	2.25	3.0	3.75	V	Active, I _O = -6mA, T _A = +25°C
Line Regulation	ΔV _{IRED(ΔVDD)}		—	—	-35	—	dB	Active, V _{DD} =6V to 12V
High-Level Output Voltage	I _{OH}	7	9	-4.0	—	—	mA	V _{DD} = Alarm, I/O active, V _O = V _{DD} -2V
OFF Leakage Current High	I _{OZ}	11	12	—	—	1.0	μA	V _O = V _{DD}
OFF Leakage Current Low	I _{OZ}	11	12	—	—	-1.0	μA	V _O = V _{SS}
Low V _{DD} Alarm Threshold	V _{DD(th)}		—	6.5	7.2	7.8	V	
Common Mode Voltage	V _{IC}	1, 2, 3	—	V _{DD} -4	—	V _{DD} -2	V	Any Alarm Condition
Smoke Comparator Ref. Volt.	V _{REF}	Int.	—	V _{DD} -3.92	—	V _{DD} -3.08	V	Any Alarm Condition

* Limits over the operating temperature range are based on characterization data.

Characteristics are production tested at +25°C.

Typical values are at +25°C and are given for circuit design information only.



**PHOTOELECTRIC SMOKE DETECTOR
WITH INTERCONNECT**

AC ELECTRICAL CHARACTERISTICS

(TA=-25°C ~ 75°C)

Characteristics	Sym.	V _{DD}	Min.	Typ.	Max.	Unit	Conditions
Oscillator Period	T _{OSC}	9	9.4	10.5	11.5	ms	
Led Pulse Period	T _{LED1}	9	39	—	48	s	No Local or Remote Smoke
	T _{LED2}	9	None	—	—	s	Remote Smoke only
	T _{LED3}	9	0.45	0.50	0.55	s	Local Smoke or Test
Led Pulse Width	T _{W(LED)}	9	9.5	—	11.5	ms	
Strobe Pulse Period	T _{ST1}	9	9.6	—	11.9	s	No Local or Remote Smoke
	T _{ST2}	9	1.8	2.0	2.2	s	After 1 or 3 Valid Samples
	T _{ST3}	9	0.8	1.0	1.1	s	After 2 or 3 Valid Samples and During Local Alarm
	T _{ST4}	9	7.2	8.0	8.9	s	Remote Alarm
	T _{ST5}	9	38.9	—	47.1	s	Chamber Test or Low Supply Test , No Local Alarm
	T _{ST6}	9	300	336	370	ms	Pushbutton Test , No Alarm
Strobe Pulse Width	T _{W(ST)}	9	9.5	—	11.5	ms	
I _{RED} Pulse Period	T _{IREDD1}	9	9.6	—	11.9	s	No Local or Remote Smoke
	T _{IREDD2}	9	1.8	2.0	2.2	s	After 1 or 3 Valid Samples
	T _{IREDD3}	9	0.8	1.0	1.1	s	After 2 or 3 Valid Samples and During Local Alarm
	T _{IREDD4}	9	7.2	8.0	8.9	s	Remote Alarm
	T _{IREDD5}	9	38.9	—	47.1	s	Chamber Test , No Local Alarm
	T _{IREDD6}	9	300	336	370	ms	Pushbutton Test , No Alarm
I _{RED} Pulse Width	T _{W(IREDD)}	9	94	—	116	μs	
I _{RED} Rise Time	T _{r(IREDD)}		—	—	30	μs	10% to 90%
I _{RED} Fall Time	T _{f(IREDD)}		—	—	200	μs	90% to 10%
I/O to Active Delay	T _{d(IO)}	9	—	0	—	s	Local Alarm
I/O Charge Dump Duration	T _{dump}	9	0.9	1.0	1.1	s	End of Local Alarm or Test
Rising Edge on I/O to Alarm	T _{r(IO)}	9	—	—	1.34	s	No Local Alarm
Horn Warning Pulse Period	T _{HORN}	9	38.9	—	47.1	s	Low Supply and Degraded Chamber Sensitivity
Horn Warning Pulse Width	T _{W(HORN)}	9	9.5	—	11.5	ms	Low Supply and Degraded Chamber Sensitivity
Horn ON Time	T _{ON(HORN)}	9	450	500	550	ms	Local or Remote Alarm
Horn OFF Time	T _{OFF1(HORN)}	9	450	500	550	ms	Local or Remote Alarm
	T _{OFF2(HORN)}	9	1350	1500	1650	ms	Local or Remote Alarm

* Limits over the operating temperature range are based on characterization data.

Characteristics are production tested at +25°C.

Typical values are at +25°C and are given for circuit design information only.



PHOTOELECTRIC SMOKE DETECTOR
WITH INTERCONNECT

APPLICATION DIAGRAM

(一) STAND-ALONE :

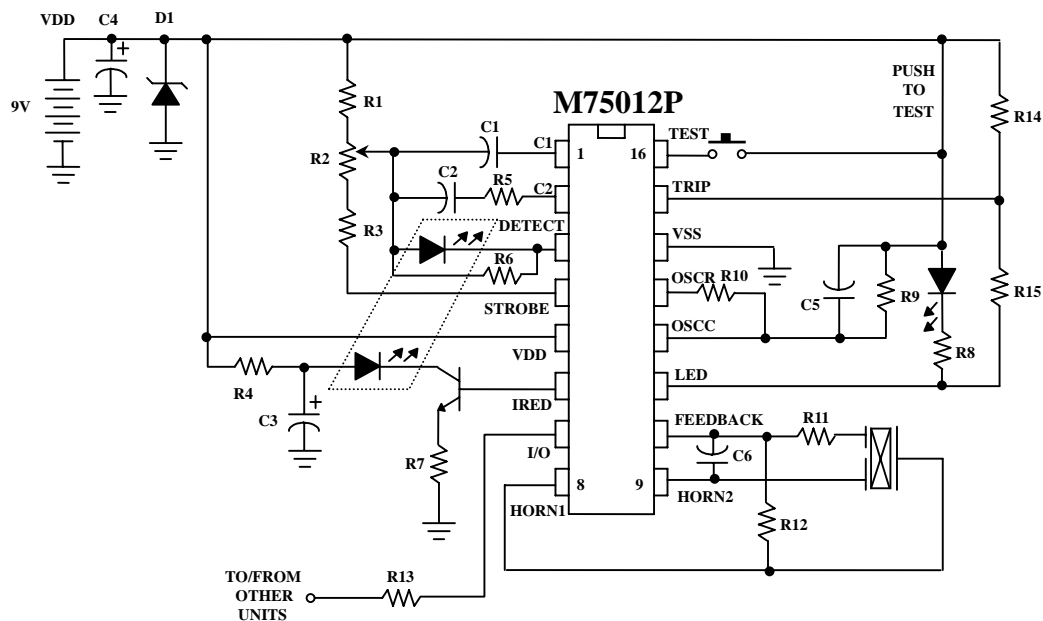

C1	0.047 μ F	R1	5.6K Ω
C2	4700pF	R2	5K Ω
C3	100 μ F	R3	8.2K Ω
C4	22 μ F	R4	1K Ω
C5	1500pF	R5	560 Ω
C6	1000pF	R6	200K Ω
		R7	4.7 Ω ~ 22 Ω
		R8	330 Ω
		R9	7.5M Ω
		R10	100K Ω
		R11	200K Ω
		R12	2M Ω
		R13	220 Ω
		R14	100K Ω
		R15	47K Ω

1. Value for R11、R12 and C6 may differ depending on type of piezoelectric horn used.
2. C2 and R7 are used for coarse sensitivity adjustment. Typical values are shown.
3. C4 should be 22 μ F if B1 is a carbon battery. C4 could be reduced to 1 μ F when an alkaline battery is used.



PHOTOELECTRIC SMOKE DETECTOR
WITH INTERCONNECT

(二) NETWORK :

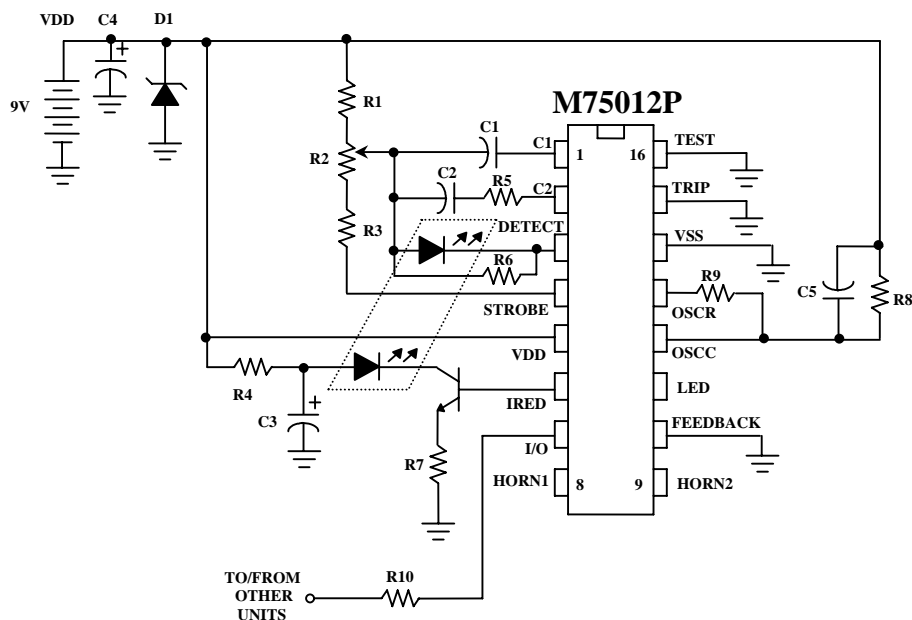

C1	0.047 μ F	R1	5.6K Ω
C2	4700pF	R2	5K Ω
C3	100 μ F	R3	8.2K Ω
C4	22 μ F	R4	1K Ω
C5	1500pF	R5	560 Ω
		R6	200K Ω
		R7	4.7 Ω ~ 22 Ω
		R8	7.5M Ω
		R9	100K Ω
		R10	220 Ω

1. C2 and R7 are used for coarse sensitivity adjustment. Typical values are shown.
2. C4 should be 22 μ F if B1 is a carbon battery. C4 could be reduced to 1 μ F when an alkaline battery is used.
3. FEEDBACK (PIN10)、TRIP (PIN15) and TEST (PIN16) must connect to ground.

* All specs and applications shown above subject to change without prior notice.
(以上電路及規格僅供參考,本公司得逕行修正)