

TOSHIBA Bi-CD Integrated Circuit Silicon Monolithic

TB6608FNG

Stepping Motor Driver IC

The TB6608FNG is a PWM constant-current type stepping motor driver IC designed for sinusoidal-input micro-step control of stepping motors.

The TB6608FNG can be used in applications that require 2-phase, 1-2-phase, W1-2-phase and 2W1-2 phase excitation modes. The TB6608FNG is capable of forward and reverse driving of a 2-phase bipolar stepping motor using only a clock signal.

Features

- Motor power supply voltage: $V_M = 15\text{ V}$ (max)
- Control power supply voltage: $V_{CC} = 2.7\text{ to }6\text{ V}$
- Output current: $I_{out} \leq 0.8\text{ A}$ (max)
- Output ON-resistance: $R_{on} = 1.5\ \Omega$ (upper and lower sum@ $V_M = 5\text{ V}$)
- Decoder that enables microstep control with the clock signal
- Selectable phase excitation modes (2, 1-2, W1-2 and 2W1-2)
- Internal pull-down resistors on inputs: $200\text{ k}\Omega$ (typ.)
- Output monitor pin (\overline{MO})
- Thermal shutdown (TSD) and undervoltage lockout (UVLO) circuits
- Small surface-mount package (SSOP20: 0.65 mm lead pitch)

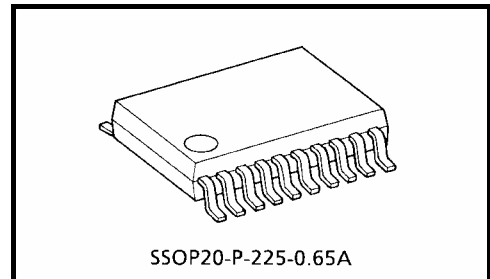

Weight: 0.09 g (typ.)

- This product has a MOS structure and is sensitive to electrostatic discharge. When handling this product, ensure that the environment is protected against electrostatic discharge by using an earth strap, a conductive mat and an ionizer. Ensure also that the ambient temperature and relative humidity are maintained at reasonable levels.
- Do not insert devices in the wrong orientation or incorrectly. Otherwise, it may cause the device breakdown, damage and/or deterioration.

About solderability, following conditions were confirmed

- Solderability
 - (1) Use of Sn-37Pb solder Bath
 - solder bath temperature = 230°C
 - dipping time = 5 seconds
 - the number of times = once
 - use of R-type flux
 - (2) Use of Sn-3.0Ag-0.5Cu solder Bath
 - solder bath temperature = 245°C
 - dipping time = 5 seconds
 - the number of times = once
 - use of R-type flux

Block Diagram

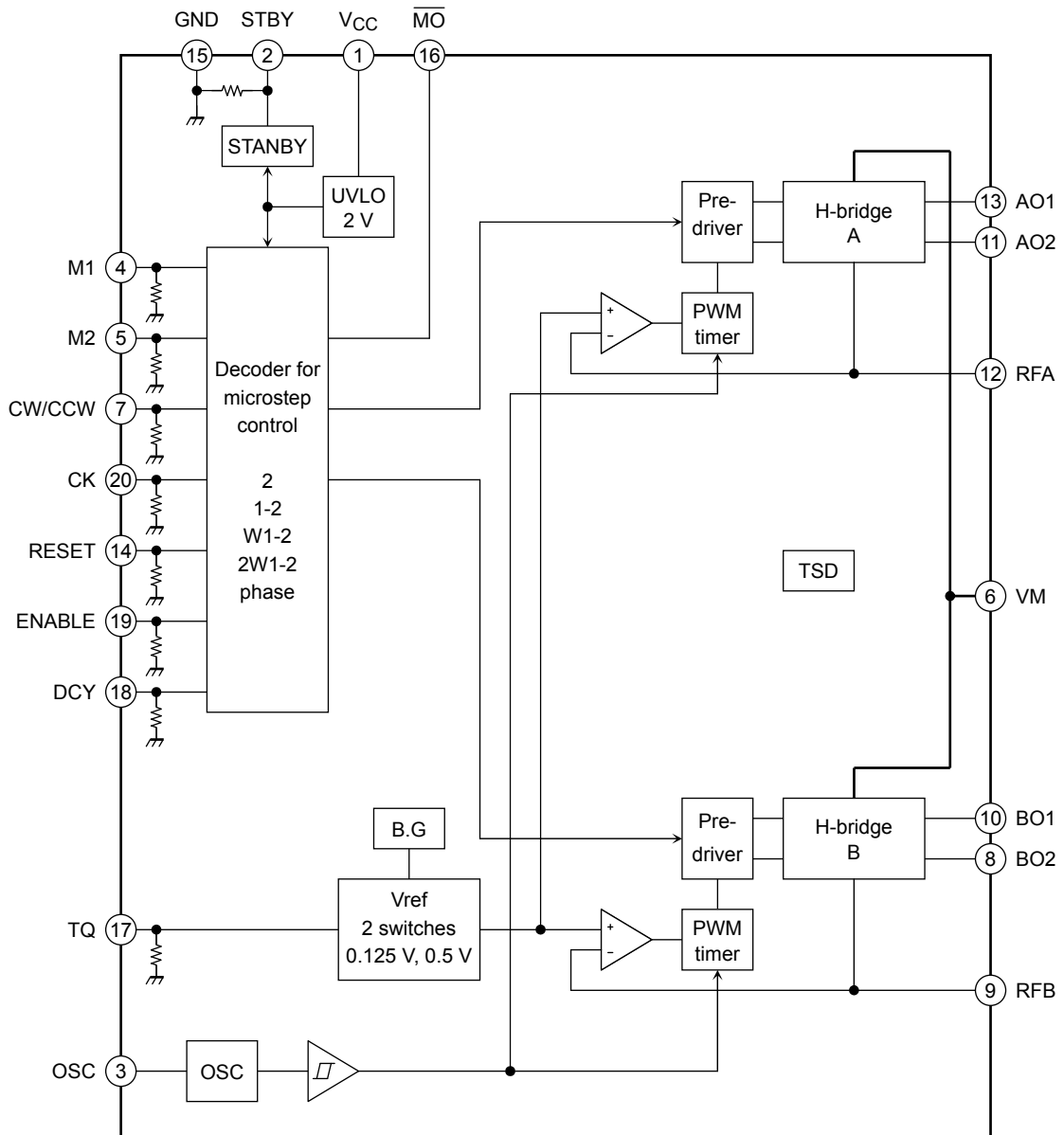

Vref Voltage Setting

Input	Vref
TQ	
L	0.125 V
H	0.5 V



Pin Function

Pin No.	Symbol	Functional Description	Remarks
1	V _{CC}	Power supply pin for logic block	V _{CC (opr)} = 2.7 to 5.5 V
2	STBY	Standby input	See the Input Signals and Operating Modes table.
3	OSC	Connection pin for an external capacitor used for internal oscillation	
4	M1	Excitation mode setting input 1	See the Excitation Mode Settings table.
5	M2	Excitation mode setting input 2	See the Excitation Mode Settings table.
6	V _M	Power supply pin for output	V _{M (opr)} = 2.5 to 13.5 V
7	CW/CCW	Rotation direction select input	See the Input Signals and Operating Modes table.
8	BO2	B-phase output 2	Connect BO2 to a motor coil pin.
9	RFB	Connection pin for a B-phase output current detection resistor	
10	BO1	B-phase output 1	Connect BO1 to a motor coil pin.
11	AO2	A-phase output 2	Connect AO2 to a motor coil pin.
12	RFA	Connection pin for an A-phase output current detection resistor	
13	AO1	A-phase output 1	Connect AO1 to a motor coil pin.
14	RESET	Reset input	See the Input Signal and Operating Modes table.
15	GND	Ground	
16	\overline{MO}	Monitor output	Initial state: \overline{MO} = Low (open drain, pulled up by an external resistor)
17	TQ	V _{ref} setting input	See the V _{ref} Voltage Setting table.
18	DCY	Decay setting input	See the Fast-Decay Time Inserted During the Current Decay Period table.
19	ENABLE	Enable input	See the Input Signal and Operating Modes table.
20	CK	Clock input	

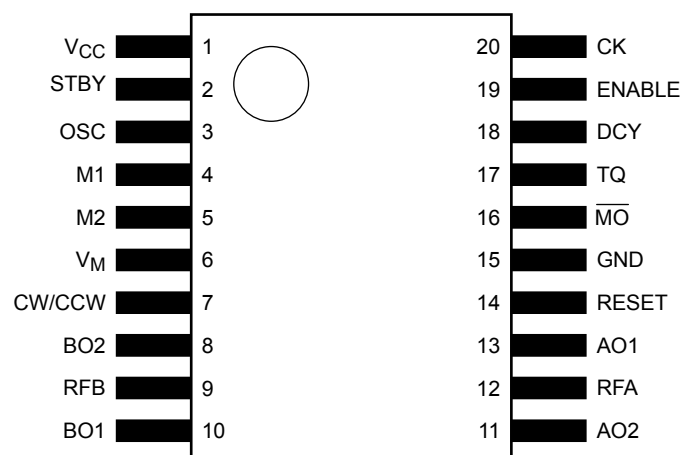
Pin Assignment



Input Signals and Operation Modes

Inputs					Operating Mode
CK	CW/CCW	RESET	ENABLE	STBY	
	L	H	H	H	CW
	H	H	H	H	CCW
X	X	L	H	H	Initial mode
X	X	X	L	H	Enable Wait mode (Outputs: high impedance)
X	X	X	X	L	Standby mode (Outputs: high impedance)

X: Don't Care

Excitation Mode Settings

Inputs		Excitation Mode
M1	M2	
L	L	2-phase
H	L	1-2-phase
L	H	W1-2-phase
H	H	2W1-2-phase

Initial A- and B-Phase Currents

(This table also applies to the currents on exit from standby mode.)

Excitation Mode	A-Phase Current	B-Phase Current
2-phase	100%	-100%
1-2-phase	100%	0%
W1-2-phase	100%	0%
2W1-2-phase	100%	0%

In this specification, the direction of current flows from AO1 to AO2 and from BO1 to BO2 are defined as the forward direction.

2-Phase Excitation (M1: L, M2: L, CW Mode)

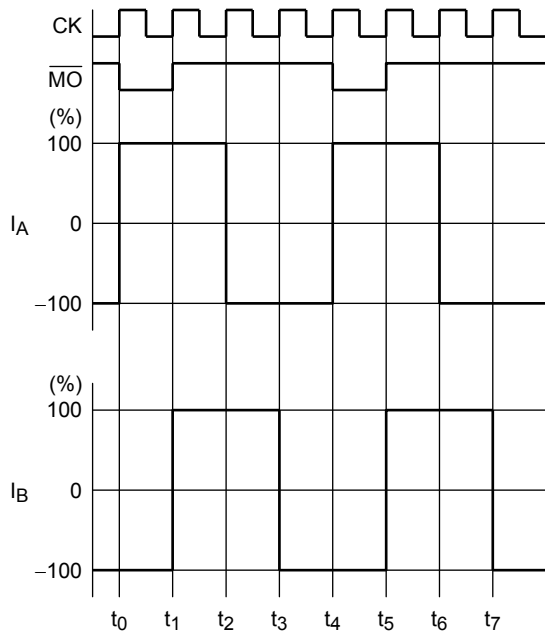

2-Phase Excitation (M1: L, M2: L, CCW Mode)

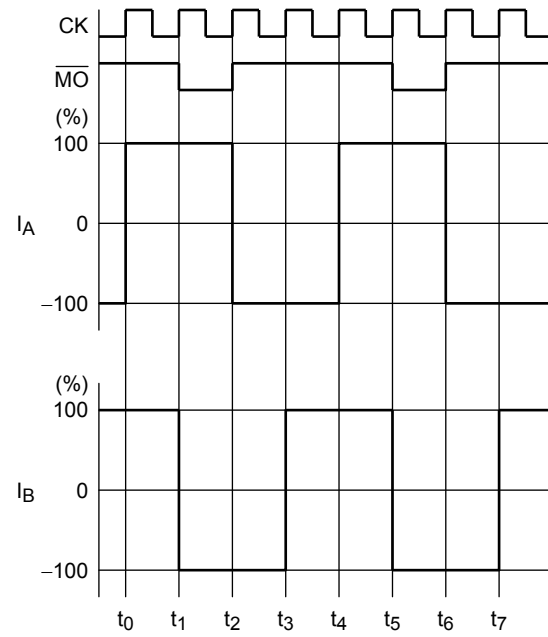

1-2-Phase Excitation (M1: H, M2: L, CW Mode)

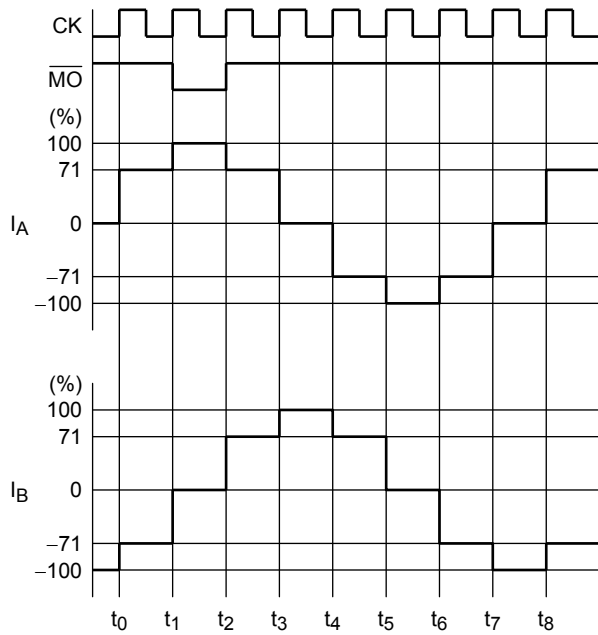

1-2-Phase Excitation (M1: H, M2: L, CCW Mode)

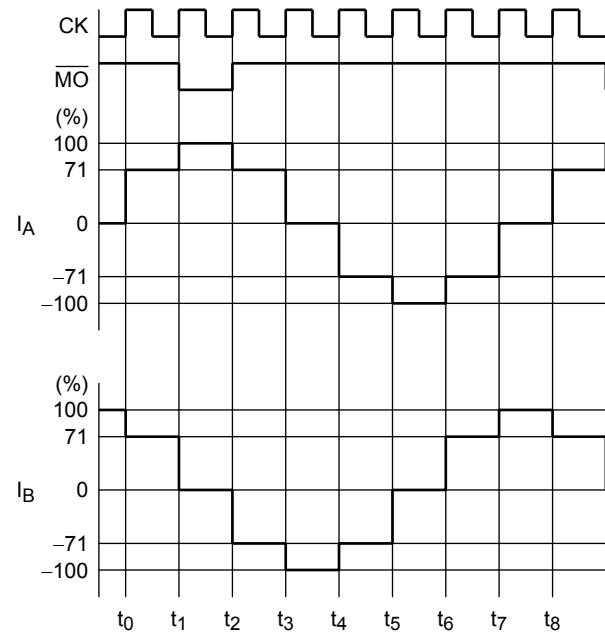

W1-2-Phase Excitation (M1: L, M2: H, CW Mode)

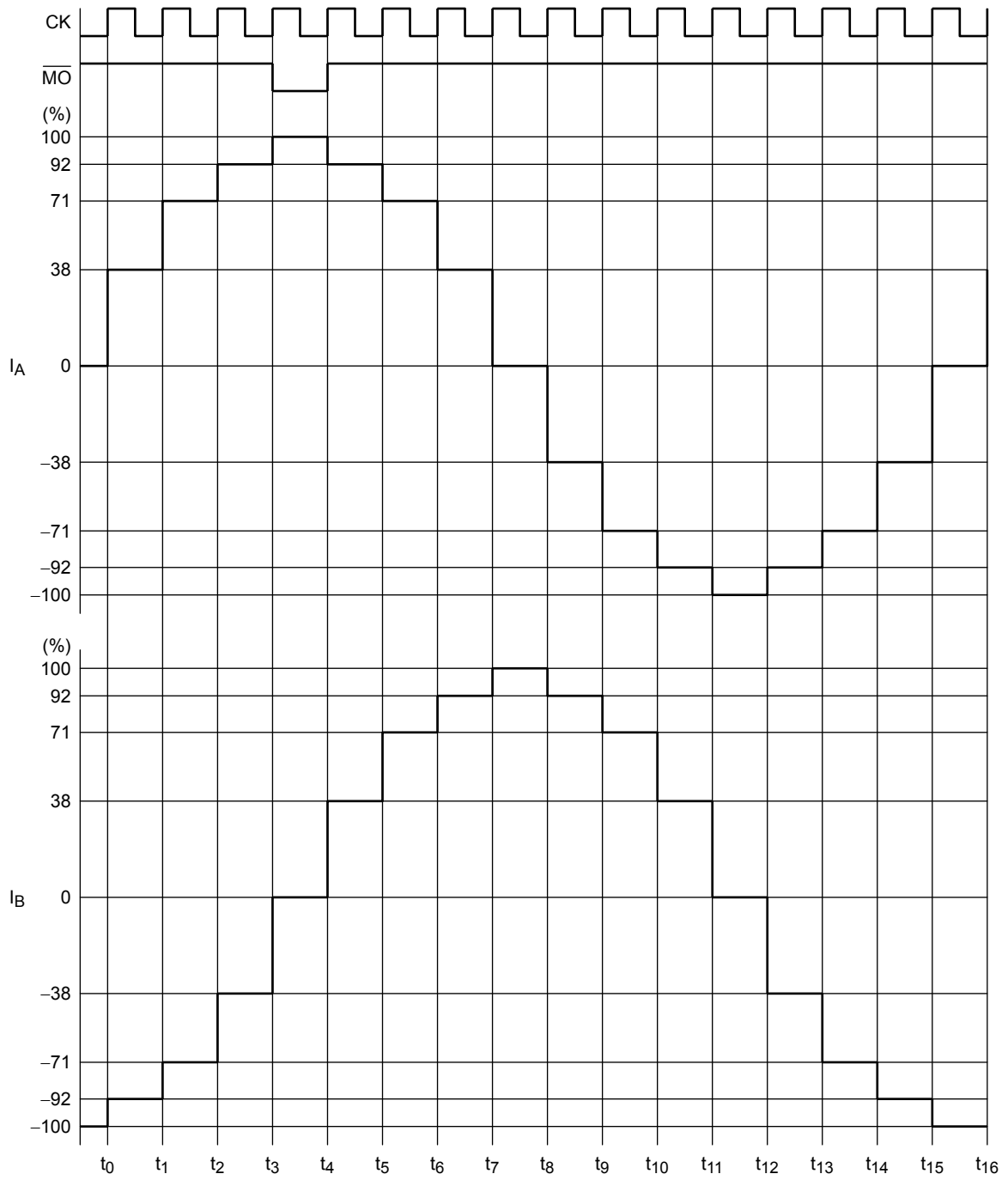

W1-2-Phase Excitation (M1: L, M2: H, CCW Mode)

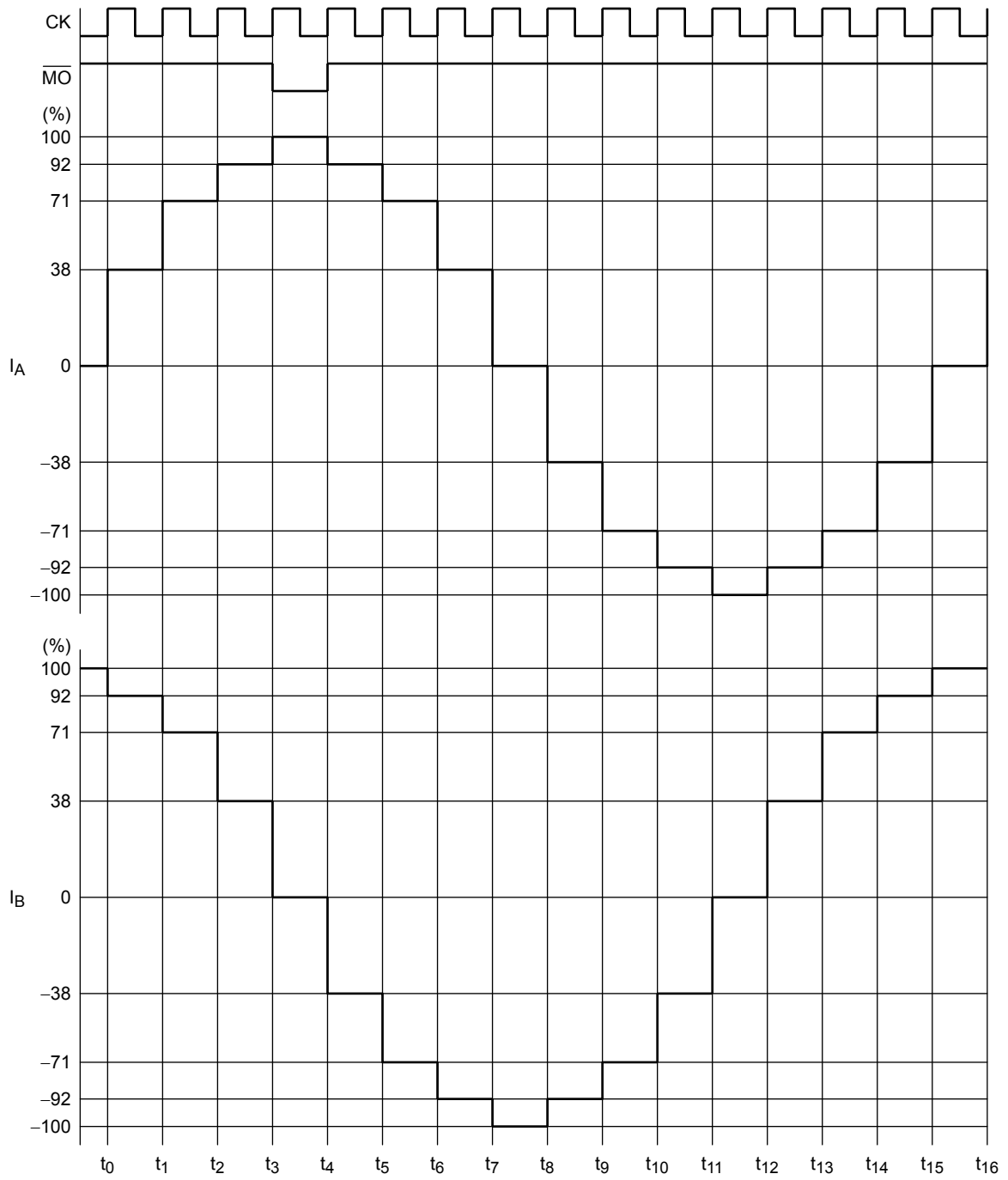

2W1-2-Phase Excitation (M1: H, M2: H, CW Mode)

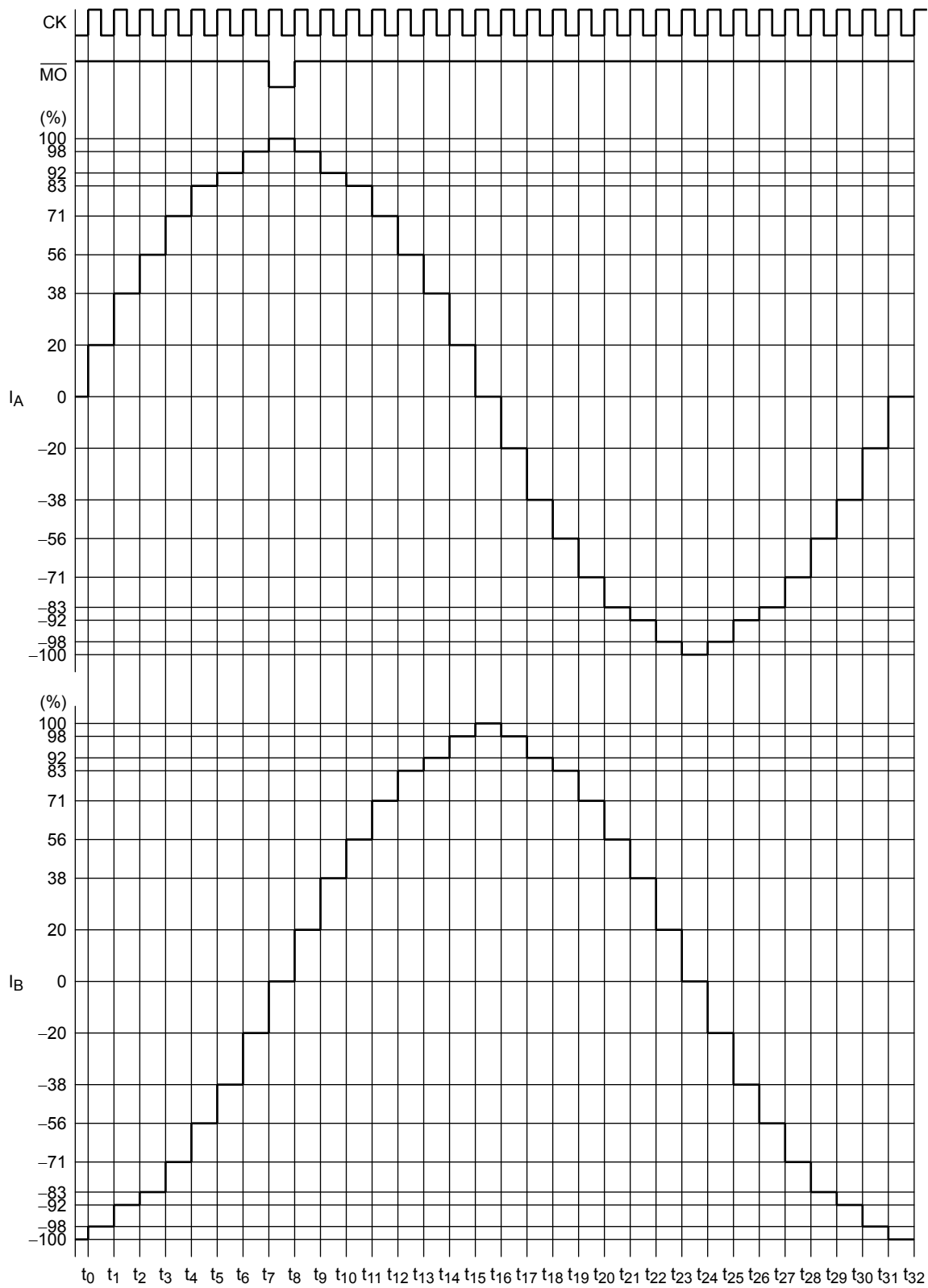

2W1-2-Phase Excitation (M1: H, M2: H, CCW Mode)

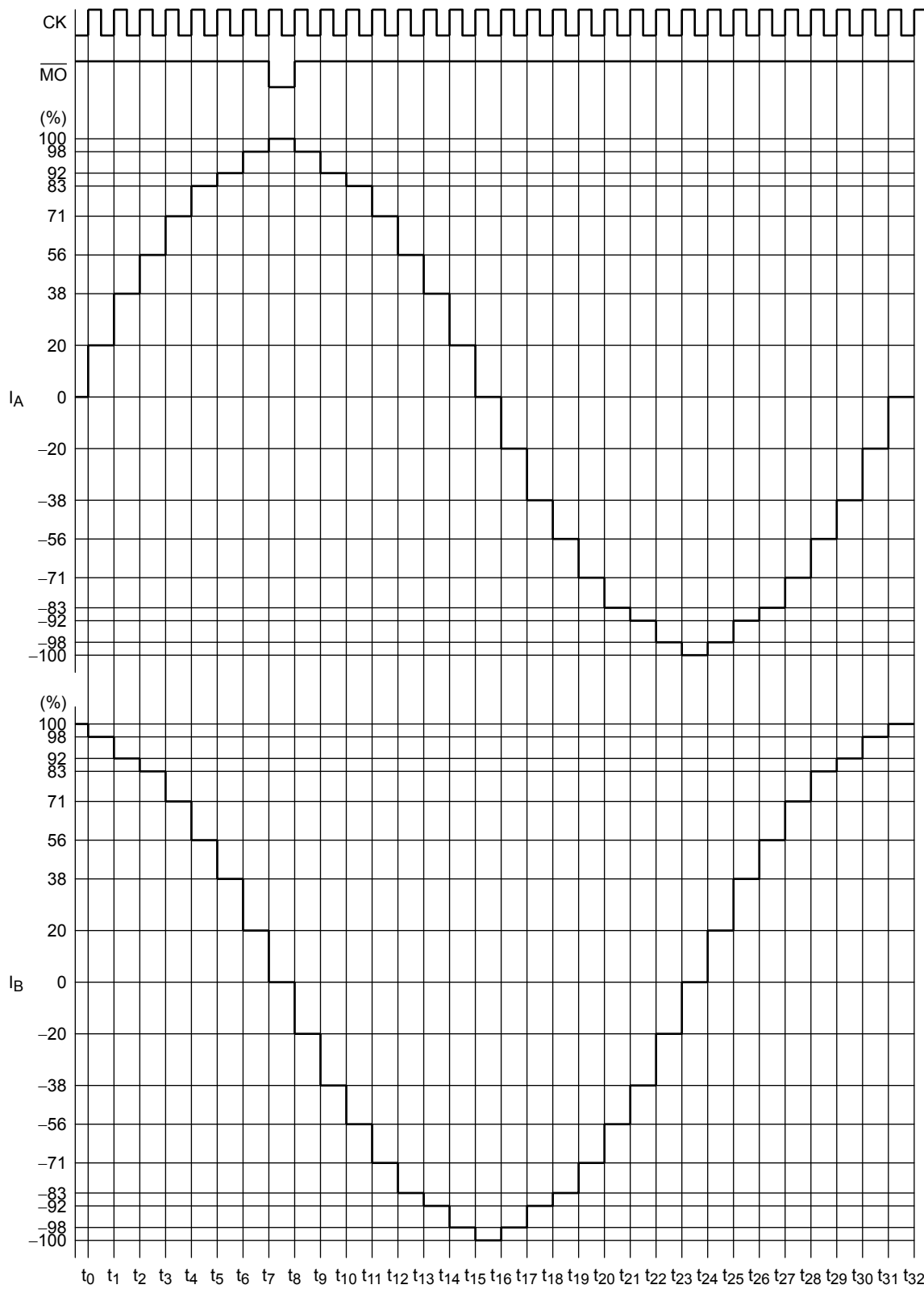

Output Current Vector Locus (Normalizing a single step to 90 degrees)

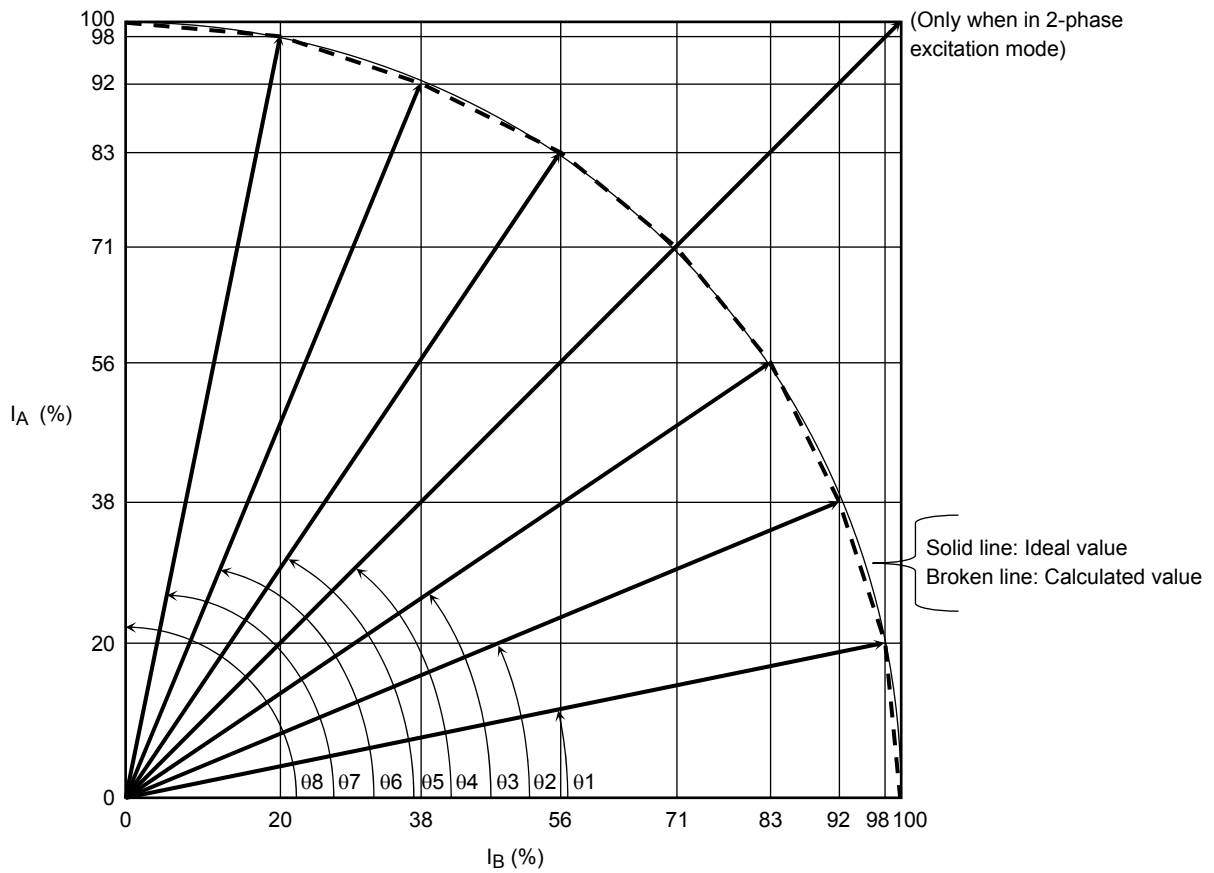

θ	Rotation Angle		Vector Length		
	Ideal	Calculated	Ideal	Calculated	
θ0	0.00°	0.00°	100	100.00	—
θ1	11.25°	11.53°	100	100.02	—
θ2	22.50°	22.44°	100	99.54	—
θ3	33.75°	34.01°	100	100.12	—
θ4	45.00°	45.00°	100	100.41	141.42
θ5	56.25°	55.99°	100	100.12	—
θ6	67.50°	67.56°	100	99.54	—
θ7	78.75°	78.47°	100	100.02	—
θ8	90.00°	90.00°	100	100.00	—
			1-2-/W1-2-/2W1-2-phase		2-phase

Relationship between the ENABLE Input and the Phase Current and \overline{MO} Outputs

Example 1: 1-2-phase excitation (M1: H, M2: L)

Setting the ENABLE signal Low disables only the output signals. On the other hand, internal logic functions continue to operate in accordance with the CK signal.

Therefore, when the ENABLE signal goes High again, the output current generation is restarted as if phases proceeded with the CK signal.

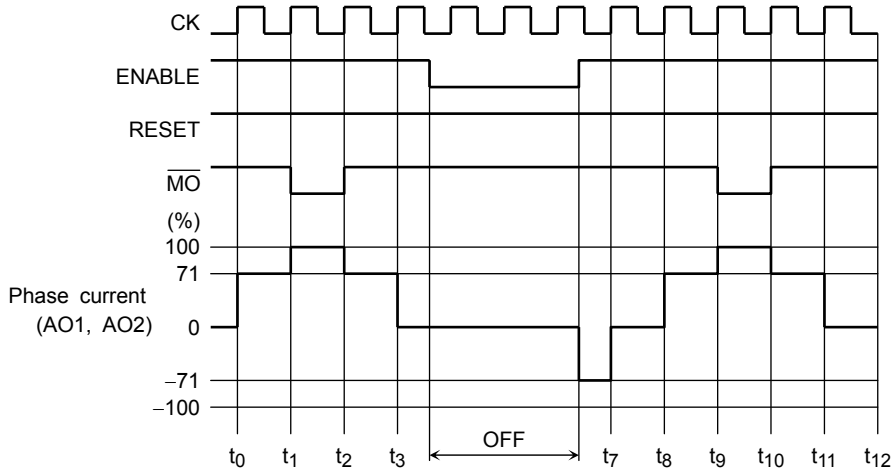

Example 2: 2W1-2-phase excitation (M1: H, M2: H)

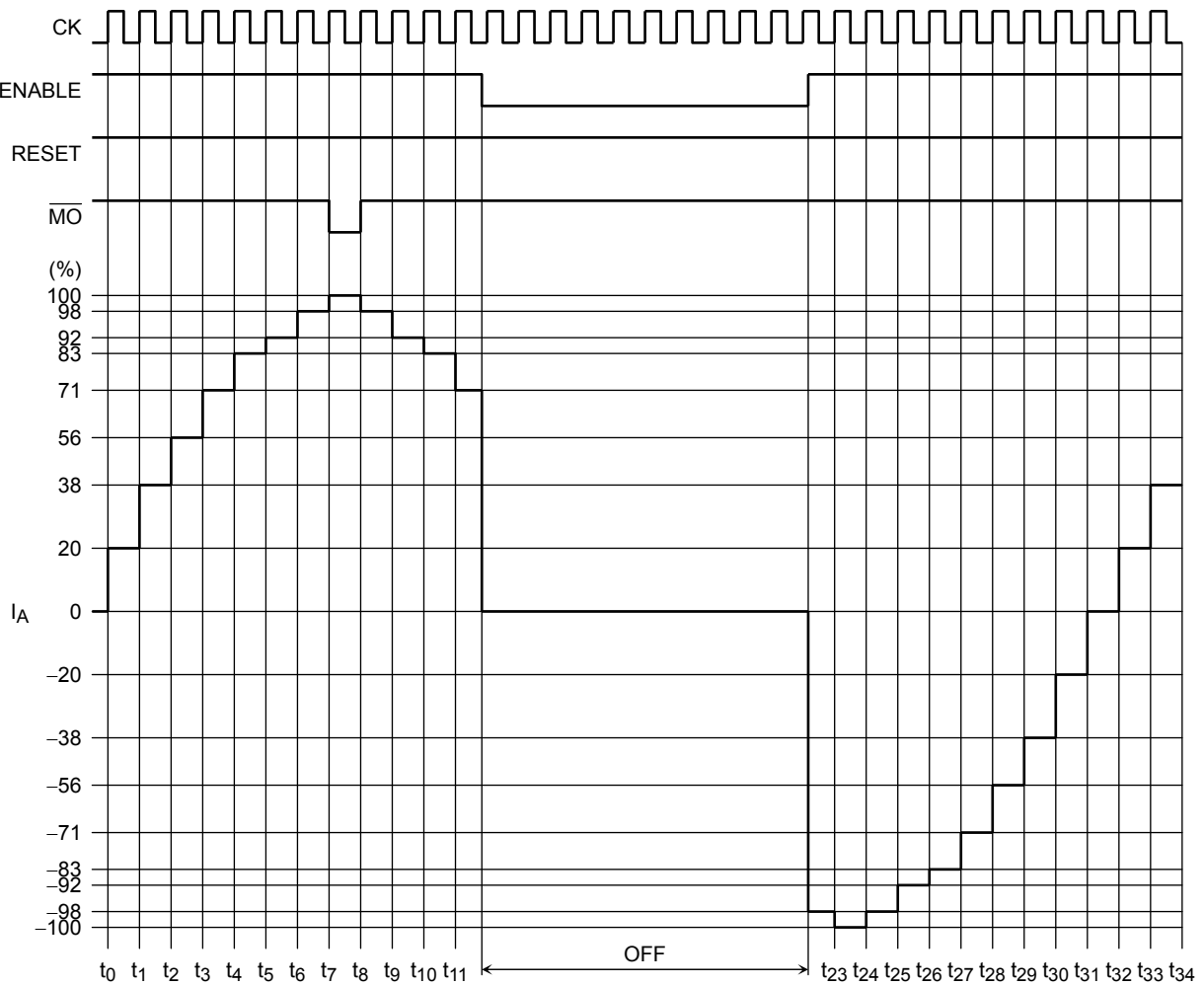

Relationship between the RESET Input and the Phase Current and \overline{MO} Outputs

Example 1: 1-2-phase excitation (M1: H, M2: L)

Setting the \overline{RESET} signal Low causes the outputs to be put in the Initial state and the \overline{MO} output to be Low. (Initial state: A-channel output current is at its peak (100%)) When the \overline{RESET} signal goes High again, the output current generation is resumed at the next rising edge of the CK signal with the state following the Initial state. If \overline{RESET} goes High when CK is already High, the output current generation is resumed immediately without waiting for the next rising edge of CK with the state following the Initial state.

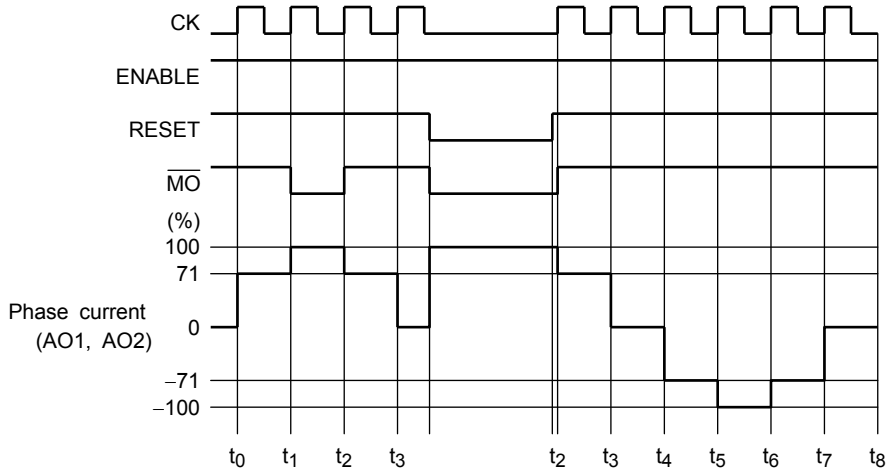

Example 2: 2W1-2 phase excitation (M1: H, M2: H)

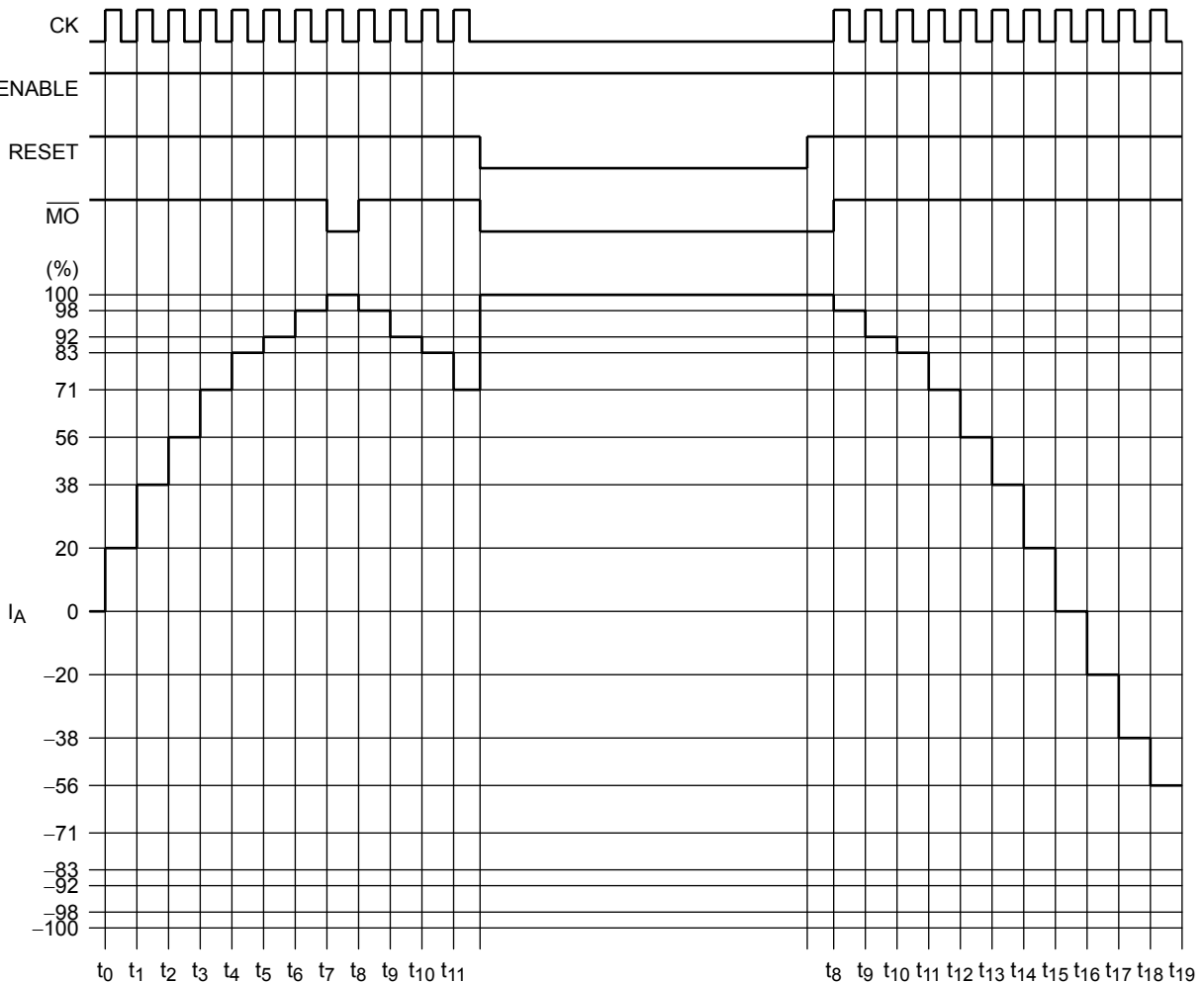

Absolute Maximum Ratings (Ta = 25°C)

Characteristics	Symbol	Rating	Unit
Power supply voltage	V _{CC}	6	V
	V _M	15	V
Output current	I _{out(AO), I_{out(BO)}}	0.8	A
	I _{MO}	1	mA
Withstand voltage of \overline{MO}	V _{MO}	V _{CC}	V
Input voltage	V _{IN}	-0.2 to V _{CC} + 0.2	V
Power dissipation	P _D	0.71 (Note 1)	W
		0.96 (Note 2)	
Operating temperature	T _{opr}	-20 to 85	°C
Storage temperature	T _{stg}	-55 to 150	°C

Note 1: IC only

Note 2: Mounted on a glass epoxy board (50 × 50 × 1.6 mm, Cu 40%)

Recommended Operating Conditions (Ta = -20 to 85°C)

Characteristics	Symbol	Test Condition	Min	Typ.	Max	Unit
Control power supply voltage	V _{CC (opr)}	—	2.7	3.3	5.5	V
Motor power supply voltage	V _{M (opr)}	—	2.5	5	13.5	V
Output current	I _{OUT}	2.5 V ≤ V _M ≤ 4.8 V	—	—	0.35	A
Output current	I _{OUT}	4.8 V < V _M ≤ 13.5 V	—	—	0.6	A
Input voltage	V _{IN}	—	—	—	V _{CC}	V
Clock frequency	f _{ck}	—	—	1	10	kHz
OSC frequency	f _{osc}	—	80	460	780	kHz
Chopping frequency	f _{chop}	—	20	115	195	kHz

Functional Descriptions

The oscillation frequency of a triangular wave f_{osc} can be calculated as follows:

$$\begin{aligned}
 f_{osc} &= \frac{I}{2 \times \Delta V_{osc} \times C_{osc}} \\
 &= \frac{101 \mu\text{A}}{2 \times (1.1 \text{ V} - 0.6 \text{ V}) \times C_{osc}} \\
 &= 1.1 \times 10^{-4} \times \frac{1}{C_{osc}}
 \end{aligned}$$

(Since this is an approximation formula, the calculation result may differ from the actual value.)

Chopper Control

Turning on the power (chop on) causes a current to flow into the coils. Once the V_{RF} voltage reaches V_{ref} , it is detected by the comparator and the power is turned off (chop off).

The off timer/counter counts the number of falling edges of the internal CK signal, which is derived from the OSC signal, and generates the motor-driving PWM signal based on the turn-off time of four CK cycles.

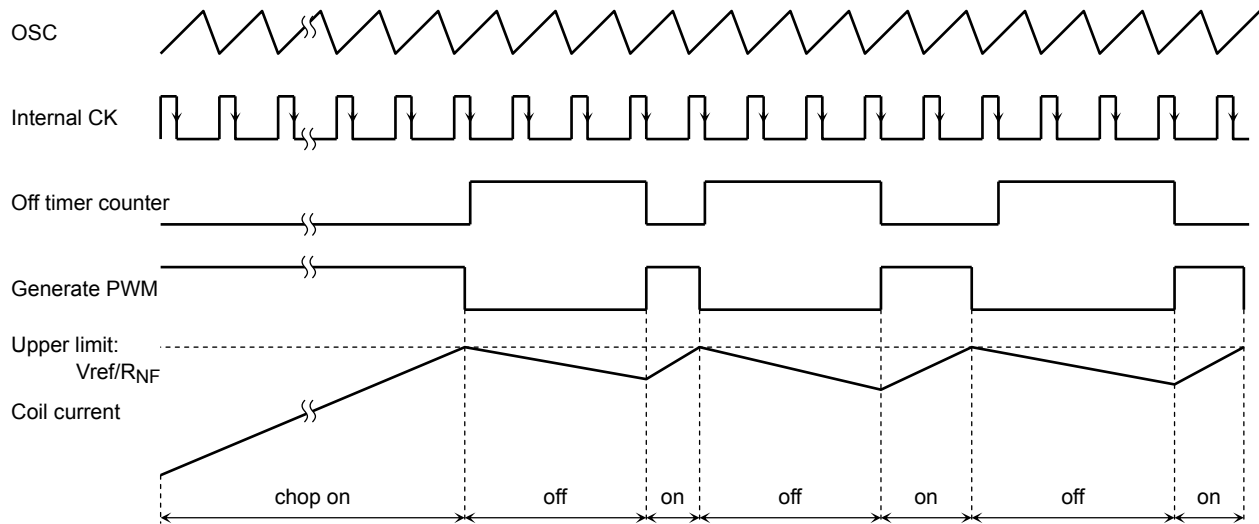

The upper limit of the current across the motor coil (i.e., the peak current in each excitation mode), I (Limit), can be calculated as follows:

$$I \text{ (Limit)} = V_{ref}/R_{NF}$$

V_{ref} equals to 0.125 V when TQ is Low, while it equals to 0.5 V when TQ is High.

R_{NF} is the value of resistors used for output current detection. One of those resistors is connected between RFA and GND, and the other is connected between RFB and GND.

Timing chart may be simplified for the sake of brevity.

PWM Control

In PWM mode, the motor operating mode changes between CW/CCW and short brake alternately.

To eliminate shoot-through current that flows from supply to ground due to the simultaneous conduction of high-side and low-side transistors in the bridge output, a dead time of 200 ns (design target value) is generated in the IC when transistors switch from on to off (t_2), or vice versa (t_4).

This permits a synchronous rectification PWM operation without controlling the dead time externally.

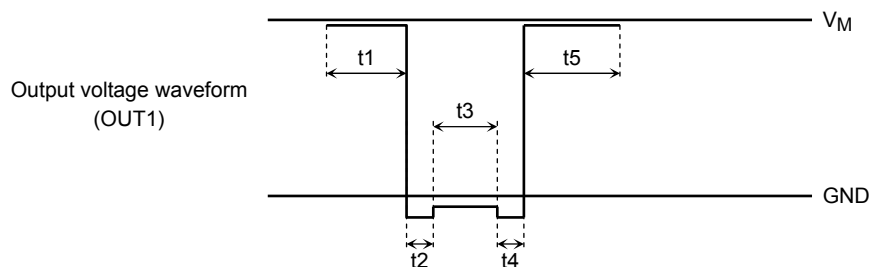
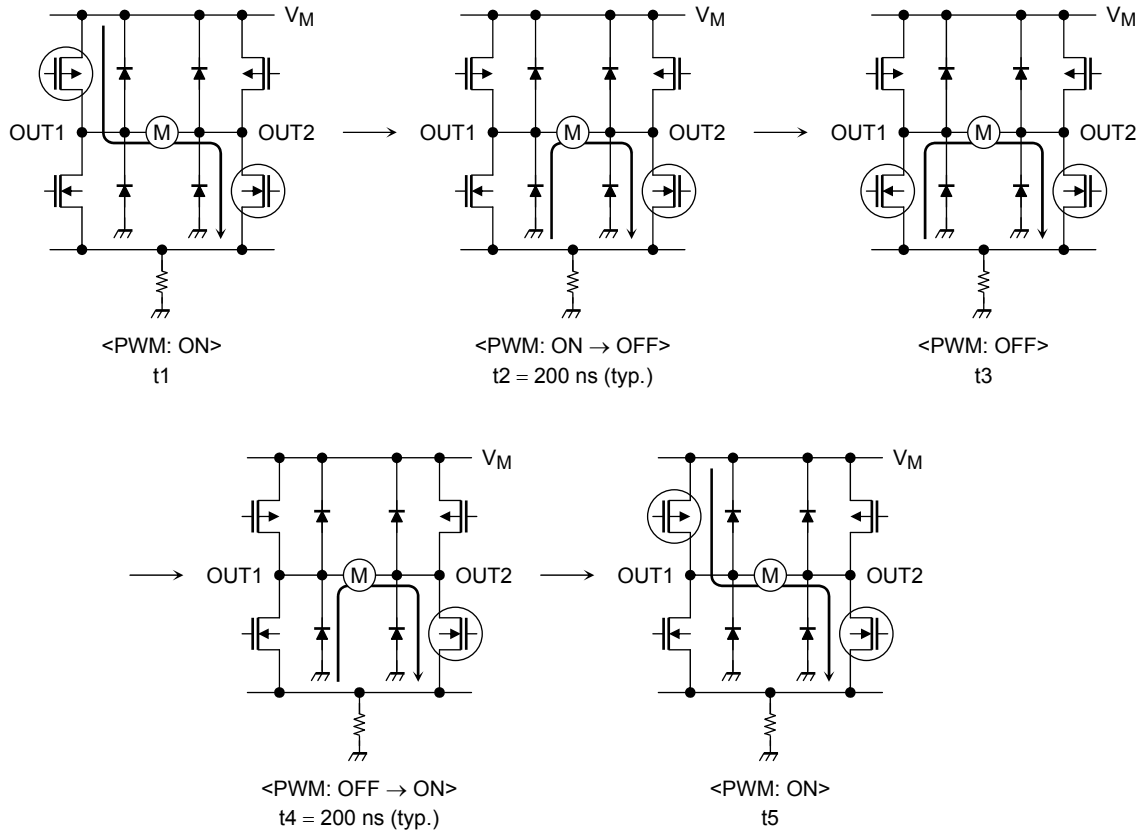

1. Constant-Current Chopping

When V_{RF} reaches the predefined V_{ref} voltage, the constant-current regulator enters Discharge mode. After four cycles of CK, an internal clock generated by OSC, the regulator moves from Discharge mode to Charge mode.

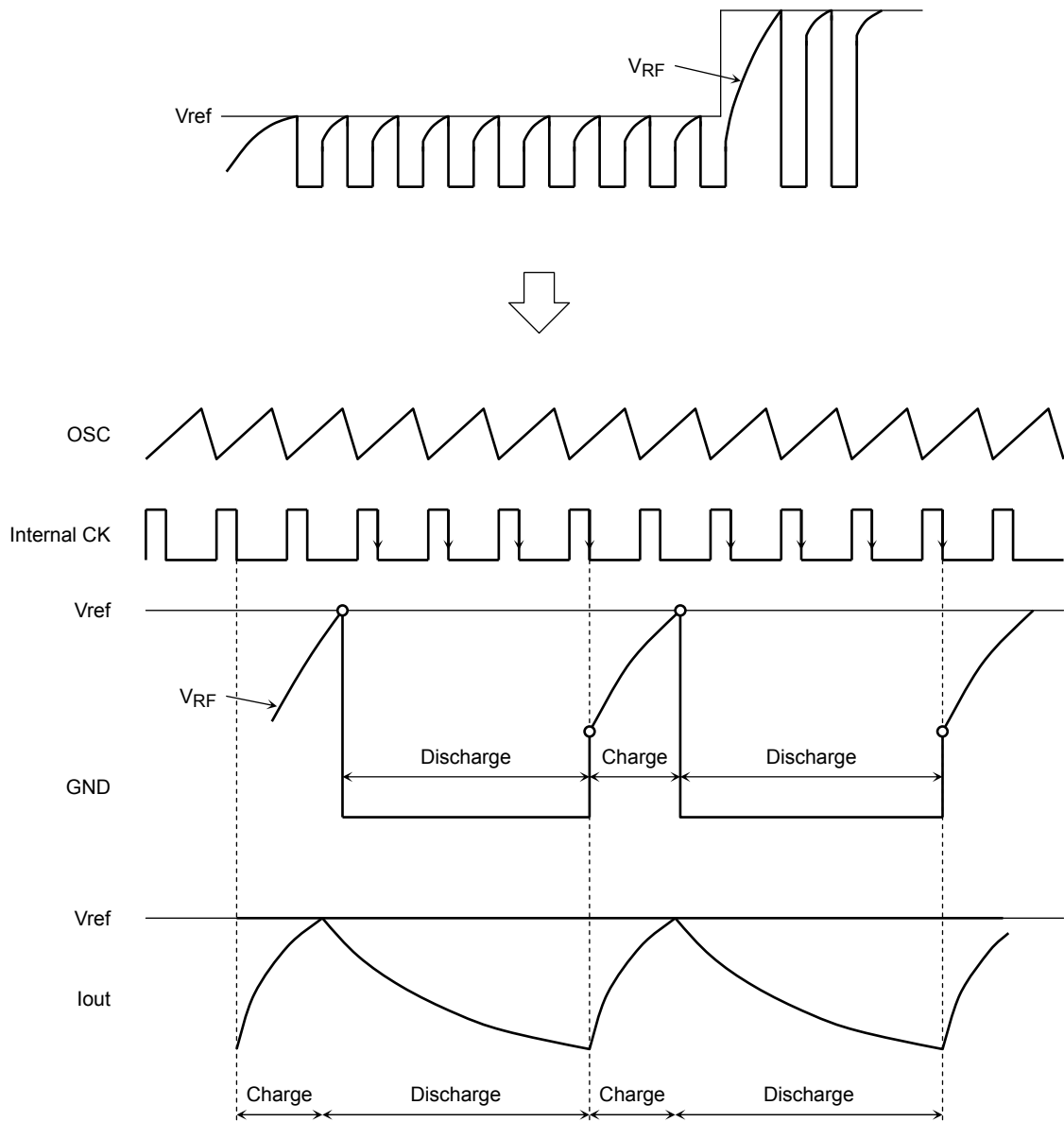

2. Changing the Predefined Current to the Lower Value

During deceleration, the regulator enters fast-decay mode immediately after the end of the current decay slope of slow-decay mode. The distortion of the current waveform can be reduced by the regenerative current from a coil that flows back to the power supply. Two CK cycles later, the regulator exits fast decay mode and enters Charge mode. (The fast-decay time, which is specified herein as two CK cycles, varies depending on the mode setting. A detailed description of the mode setting is provided in the Current Decay Mode section.)

When V_{RF} reaches the reference voltage (V_{ref}), the regulator enters Discharge mode. Four CK cycles later, the regulator exits Discharge mode and enters Charge mode. If $V_{RF} > V_{ref}$ when it enters Charge mode, however, it then reenters Discharge mode. Four CK cycles later, V_{RF} is again compared against V_{ref} . If $V_{RF} < V_{ref}$, the regulator remains in Charge mode until V_{RF} reaches V_{ref} .

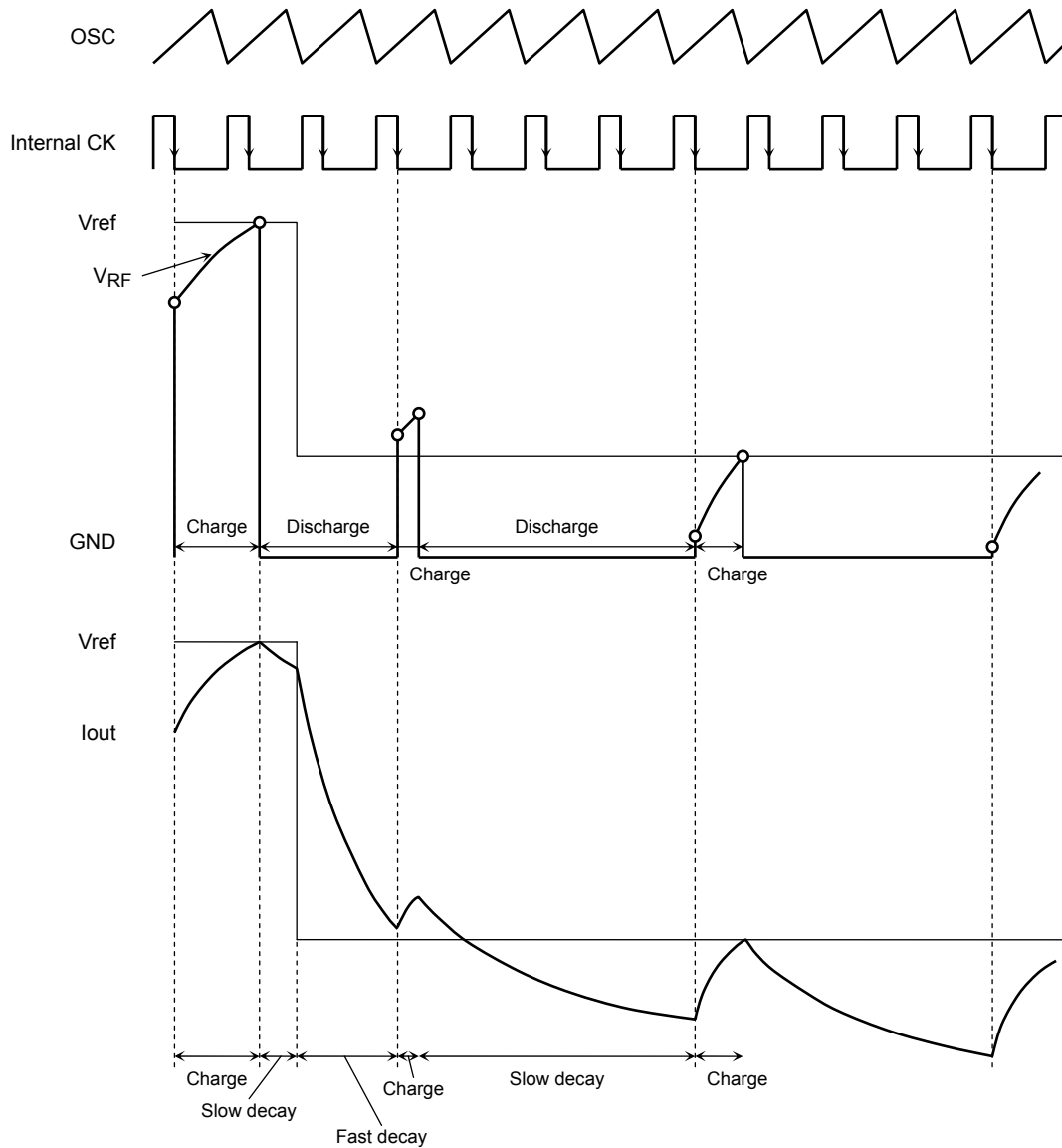

In fast-decay mode, the regenerative current from a coil flows back to the power supply as shown below.

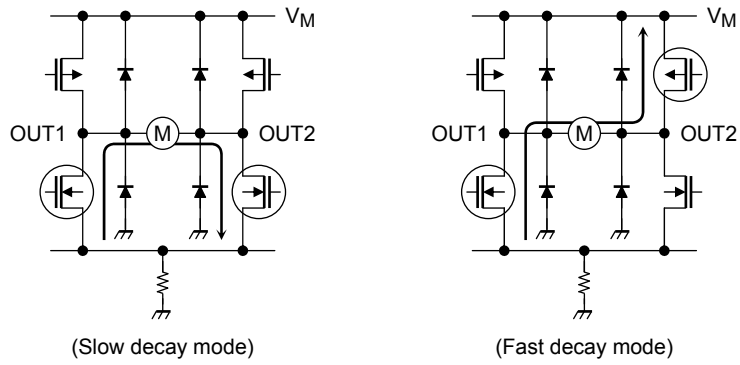

3. Changing the Predefined Current to the Higher Value

Even when the Vref voltage is increased, the regulator remains in Discharge mode for four CK cycles and then enters Charge mode. During acceleration, the current decays only in slow-decay mode.

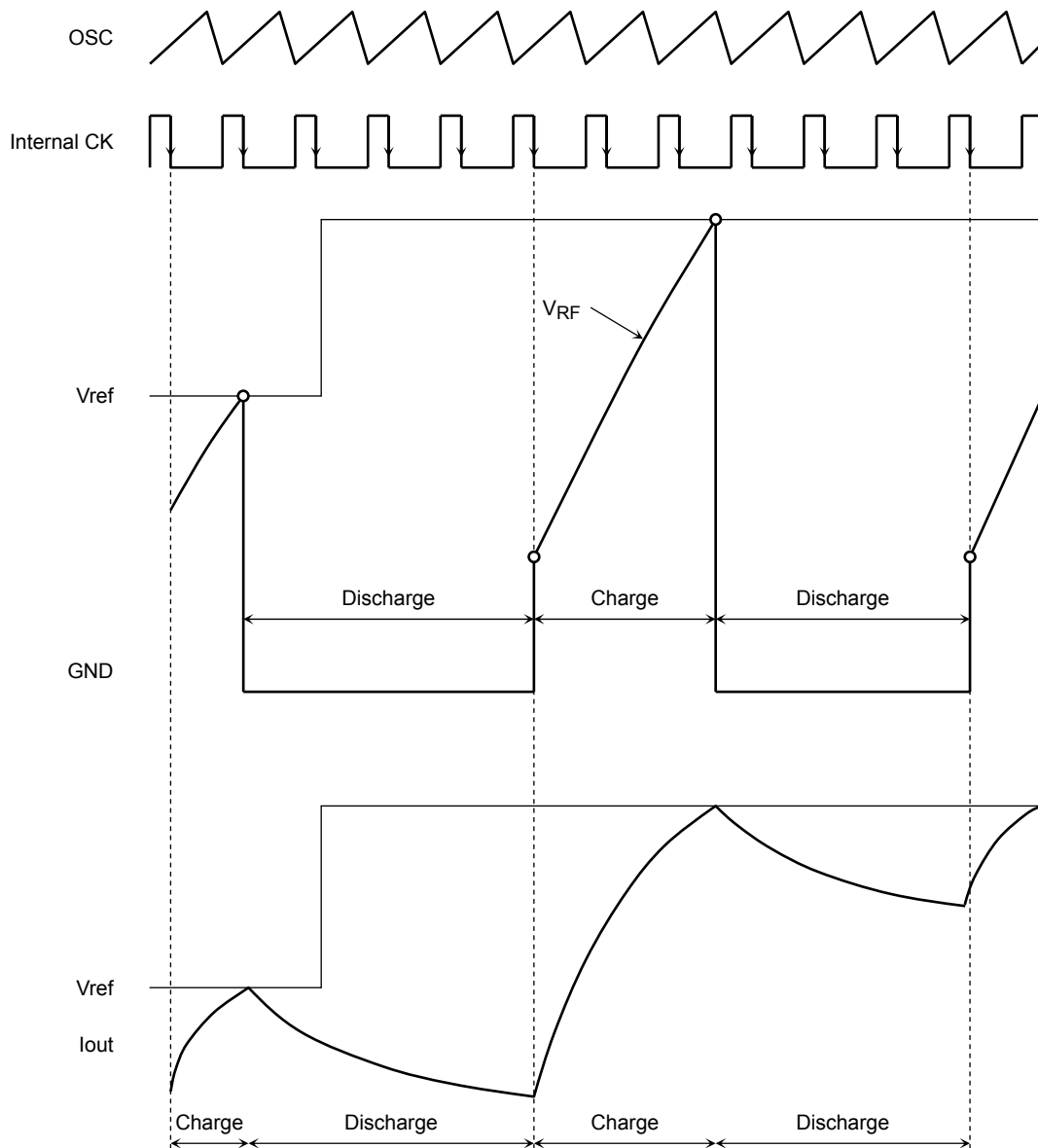

Setting the Current Decay Mode

Table Fast-Decay Time Inserted During the Current Decay Period

(, which is expressed as the number of CK cycles (an actual value may not exactly equal to the specified value).)

Input	2W1-2-Phase			W1-2-Phase			1-2-Phase		
	Predefined Current	Number of CK Cycles		Predefined Current	Number of CK Cycles		Predefined Current	Number of CK Cycles	
DCY	%	TQ = H	TQ = L	%	TQ = H	TQ = L	%	TQ = H	TQ = L
L	100			100			100		
	98	0	0						
	92	0	0	92	0	0			
	83	0	0						
	71	0	0	71	0	0	71	0	0
	56	0	0						
	38	0	0	38	0	0			
	20	0	0						
	0	0	0	0	0	0	0	0	0
H	100			100			100		
	98	2	1						
	92	2	1	92	2	1			
	83	2	1						
	71	2	1	71	4	2	71	4	2
	56	4	2						
	38	4	2	38	4	2			
	20	4	2						
	0	0	0	0	0	0	0	0	0

If no distortion can be observed in the output current waveform, the DCY pin should be kept High. The distortion reduction depends on the motor characteristics. If any distortion can be observed, the DCY pin should be kept Low. Also, it should be ensured that the DCY input is set High only when the coil of a motor has an inductance of 1.5 mH or higher where fosc is no less than 100 kHz.

Thermal Shutdown (TSD) Circuit

The TB6608FNG includes a thermal shutdown circuit, which turns the output transistors off when the junction temperature (T_j) exceeds 160°C (typ.).

The output transistors are automatically turned on when T_j cools past the shutdown threshold, which is lowered by a hysteresis of 40°C.

T_{SD} = 160°C (design target value)

ΔT_{SD} = 40°C (design target value)

- * In thermal shutdown mode, the internal circuitry and outputs assume the same states as in Enable Wait mode. Upon exit from thermal shutdown mode, they revert to those states which they assume when taken out of Enable Wait mode.

Undervoltage Lockout (UVLO) Circuit

The TB6608FNG includes an undervoltage lockout circuit, which puts the output transistors in the high-impedance state when V_{CC} decreases to 2.0 V (typ.) or lower.

The output transistors are automatically turned on when V_{CC} increases past the lockout threshold, which is raised to 2.03 V by a hysteresis of 0.03 V.

Even when UVLO circuit is tripped, internal circuitry continues to operate in accordance with the CK input like when ENABLE is set Low. Thus, after the TB6608FNG exits the UVLO mode, the RESET signal should be asserted for putting the TB6608FNG in the Initial state if necessary.

Electrical Characteristics

(Unless otherwise specified, $T_a = 25^\circ\text{C}$, $V_{CC} = 3.3\text{ V}$, $V_M = 5\text{ V}$, $R_{NF} = 2\ \Omega$, $C_{OSC} = 220\text{ pF}$.)

Characteristics	Symbol	Test Circuit	Test Condition	Min	Typ.	Max	Unit
Input voltage	$V_{IN(H)}(1)$	1	CW/CCW, CK, RESET, ENABLE, M1, M2 (@ $V_{CC} = 3.3\text{ V}$)	2	—	$V_{CC} + 0.2$	V
	$V_{IN(L)}(1)$			-0.2	—	0.8	V
	$V_{IN(H)}(2)$	1	CW/CCW, CK, RESET, ENABLE, M1, M2 (@ $V_{CC} = 5.5\text{ V}$)	2.8	—	$V_{CC} + 0.2$	V
	$V_{IN(L)}(2)$			-0.2	—	0.8	V
	$V_{IN(H)}(3)$	1	STBY, TQ, DCY	$V_{CC} \times 0.6$	—	$V_{CC} + 0.2$	V
	$V_{IN(L)}(3)$			-0.2	—	$V_{CC} \times 0.15$	V
Input hysteresis voltage	V_H	—	CW/CCW, CK, RESET, ENABLE, M1, M2	—	200	—	mV
Input current	I_{INH}	1	$V_{IN} = 3.0\text{ V}$	5	15	25	μA
	I_{INL}		$V_{IN} = \text{GND}$	—	—	1	μA
Dynamic supply current	I_{CC1}	2	Outputs: Open, ENABLE: H, RESET: H	—	4	6	mA
	I_{CC2}		ENABLE: L	—	4	6	mA
	I_{CC3}		Standby mode	—	5	10	μA
	I_{M1}		Outputs: Open, ENABLE: H, RESET: H	—	1	2	mA
	I_{M2}		ENABLE: L	—	0.5	1.0	mA
	I_{M3}		Standby mode	—	—	1	μA
Comparator reference voltage	$V_{RFA(1)}$, $V_{RFB(1)}$	3	TQ: L, 2-phase excitation	0.1	0.125	0.15	V
	$V_{RFA(2)}$, $V_{RFB(2)}$		TQ: H, 2-phase excitation	0.445	0.5	0.555	
Channel-to-channel voltage differential	ΔV_O	—	B/A, TQ: L	-11	—	11	%
Undervoltage lockout threshold at V_{CC}	Lower threshold	UVLD	(Design target value)	—	2.0	—	V
	Upper threshold	UVLC	(Design target value)	—	2.03	—	V
MO output voltage	$V_{\overline{MO}}$	—	$I_{\overline{MO}} = 1\text{ mA}$	—	—	0.5	V
OSC frequency	f_{OSC}	—	$C_{OSC} = 220\text{ pF}$	300	460	620	kHz

This table shows which inputs are TTL-compatible and which ones are CMOS-compatible. This also shows whether they are provided with hysteresis.

Input Pins	Input Level	Hysteresis
CW/CCW, CK, RESET, ENABLE, M1, M2	TTL	Yes
STBY, TQ, DCY	CMOS	No

Output Block

Characteristics			Symbol	Test Circuit	Test Condition	Min	Typ.	Max	Unit				
Output saturation voltage			$V_{SAT (U+L)}$	4	$I_{OUT} = 0.2 A$	—	0.3	0.4	V				
					$I_{OUT} = 0.6 A$	—	0.9	1.2					
Diode forward voltage			V_{FU} V_{FL}	5	$I_{OUT} = 0.6 A$	—	1	1.2	V				
						—	1	1.2					
A/B-phase chopping current (Note)	2W1-2-phase excitation	W1-2-phase excitation	1-2-phase excitation	Vector	3	$\theta = 0$ $\theta = 1/8$ $\theta = 2/8$ $\theta = 3/8$ $\theta = 4/8$ $\theta = 5/8$ $\theta = 6/8$ $\theta = 7/8$ TQ: L $R_{NF} = 2 \Omega$ $C_{OSC} = 220 pF$	—	100	—	%			
	2W1-2-phase excitation	—	—				92	98	101				
	2W1-2-phase excitation	W1-2-phase excitation	—				86	92	98				
	2W1-2-phase excitation	—	—				77	83	89				
	2W1-2-phase excitation	W1-2-phase excitation	1-2-phase excitation				65	71	77				
	2W1-2-phase excitation	—	—				50	56	62				
	2W1-2-phase excitation	W1-2-phase excitation	—				32	38	44				
	2W1-2-phase excitation	—	—				14	20	26				
	2-phase excitation						—	—	—		100	—	—
	Output transistor switching characteristics (Design target value)						t_r	7	@ load: 5 mH, 50 Ω		—	0.5	—
t_f				—	0.5	—							
t_{pLH}				CK to Output	—	5	—						
t_{pHL}					—	5	—						
t_{pLH}				RESET to Output	—	5	—						
t_{pHL}					—	5	—						
t_{pLH}				ENABLE to Output	—	1	—						
t_{pHL}					—	0.5	—						
Output leakage current			Upper	6	$V_M = 13 V$	—	—	1	μA				
			Lower			I_{OL}	—	—		1			

Note: Relative to the peak current at $\theta = 0$.

Test Circuit 1: $V_{IN(H)}$, $V_{IN(L)}$, I_{INH} , I_{INL}

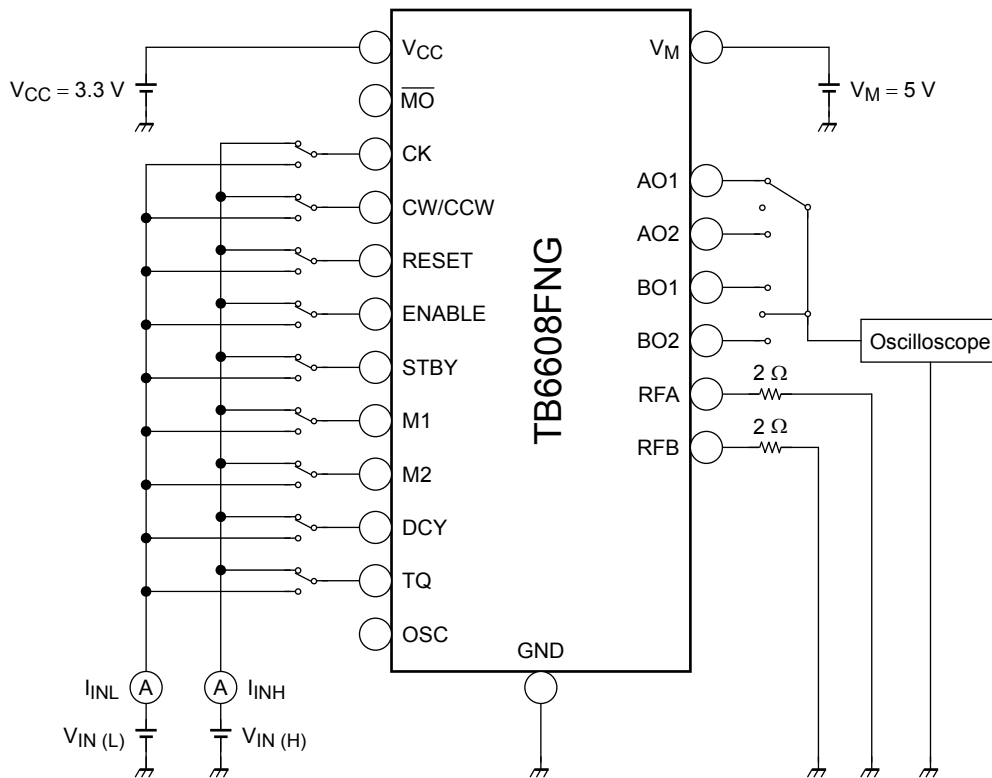

Test Circuit 2: I_{CC} , I_M

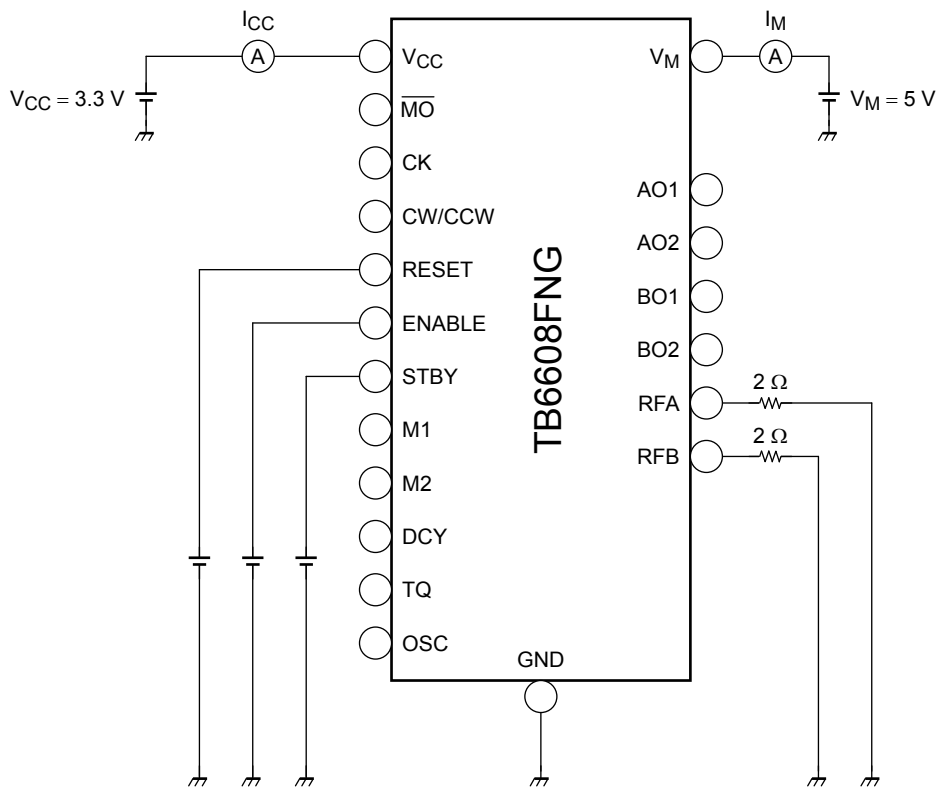

Test Circuit 3: V_{RFA} , V_{RFB}

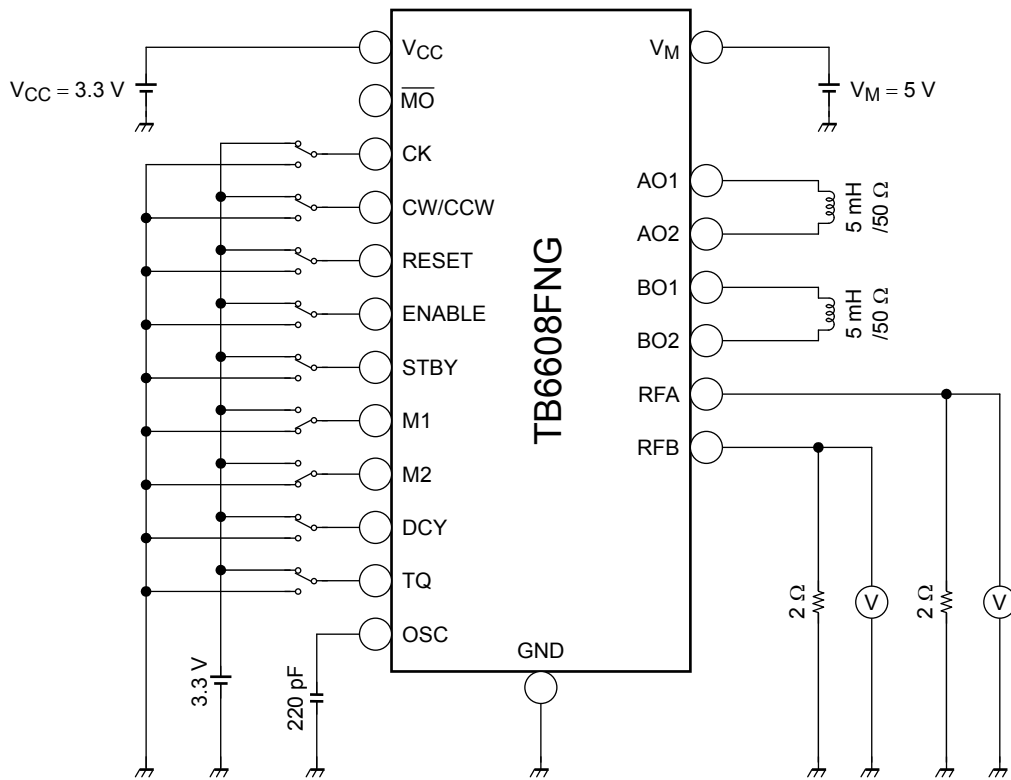

Test Circuit 4: V_{SAT} (UL)

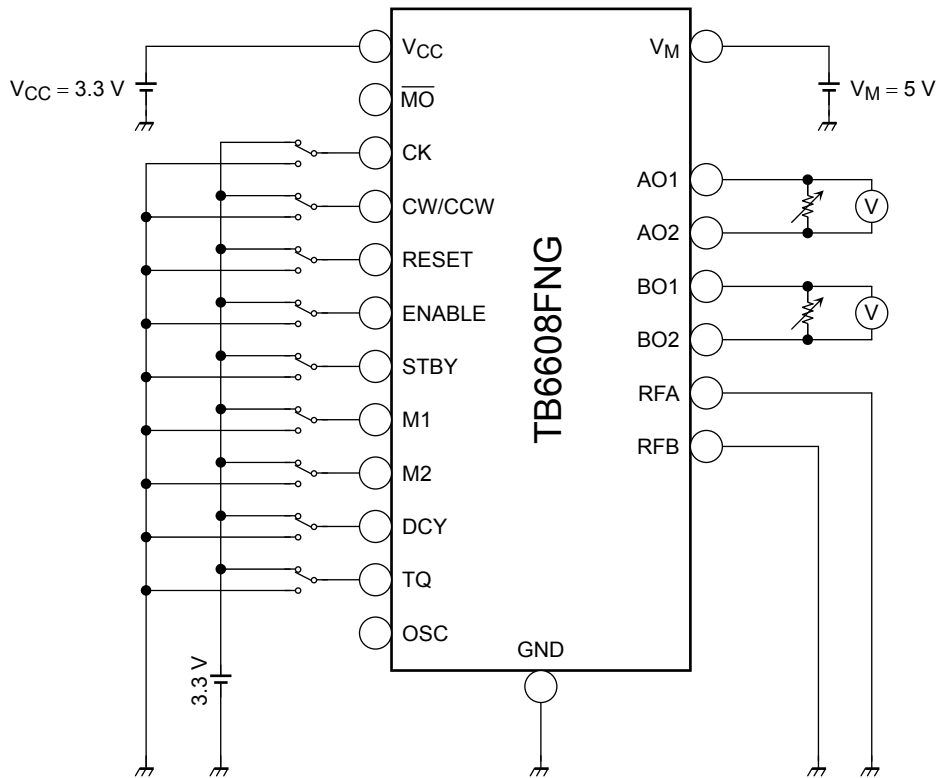

Test Circuit 5: V_{FU} , V_{FL}

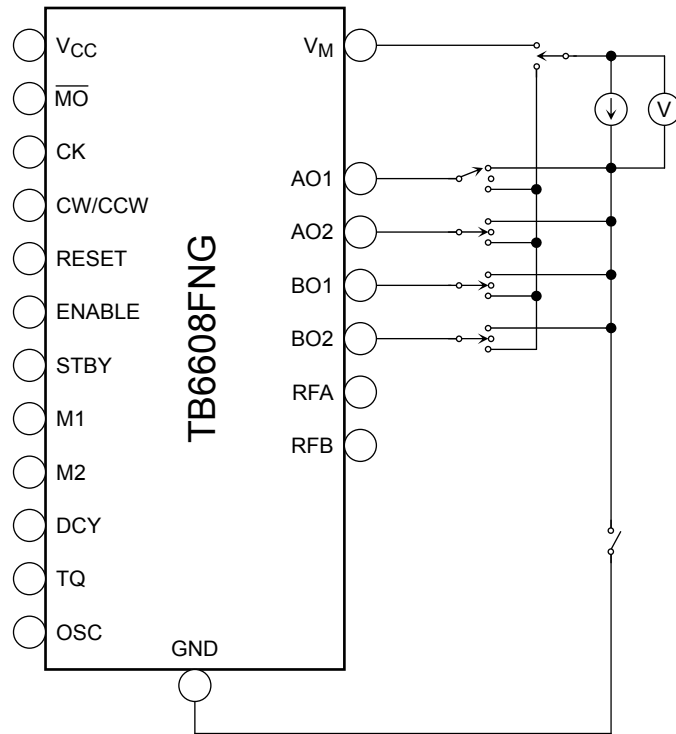

Test Circuit 6: I_{OH} , I_{OL}

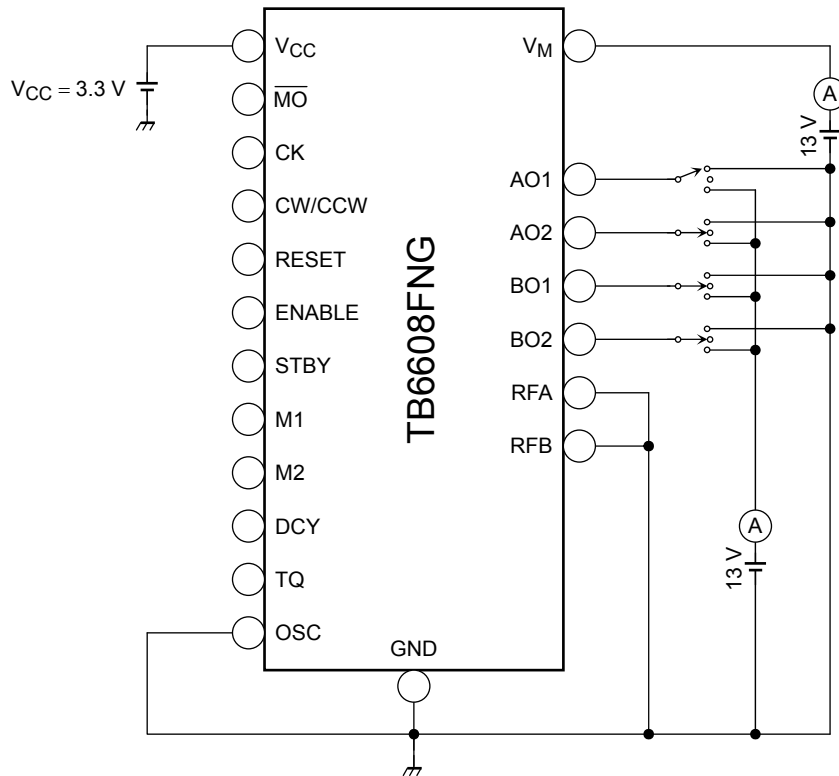

AC Electrical Characteristics, Test Circuit 7: CK (OSC) and Output Voltage

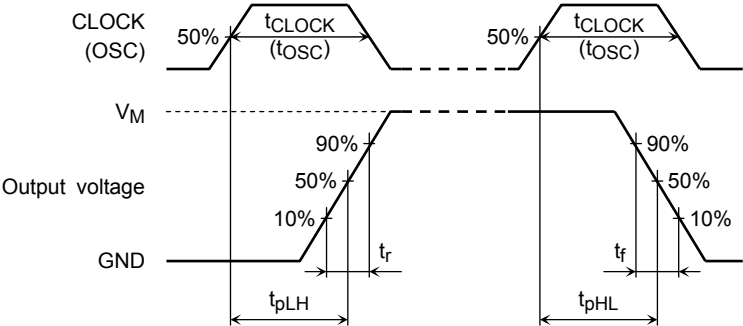

Application Circuit Example

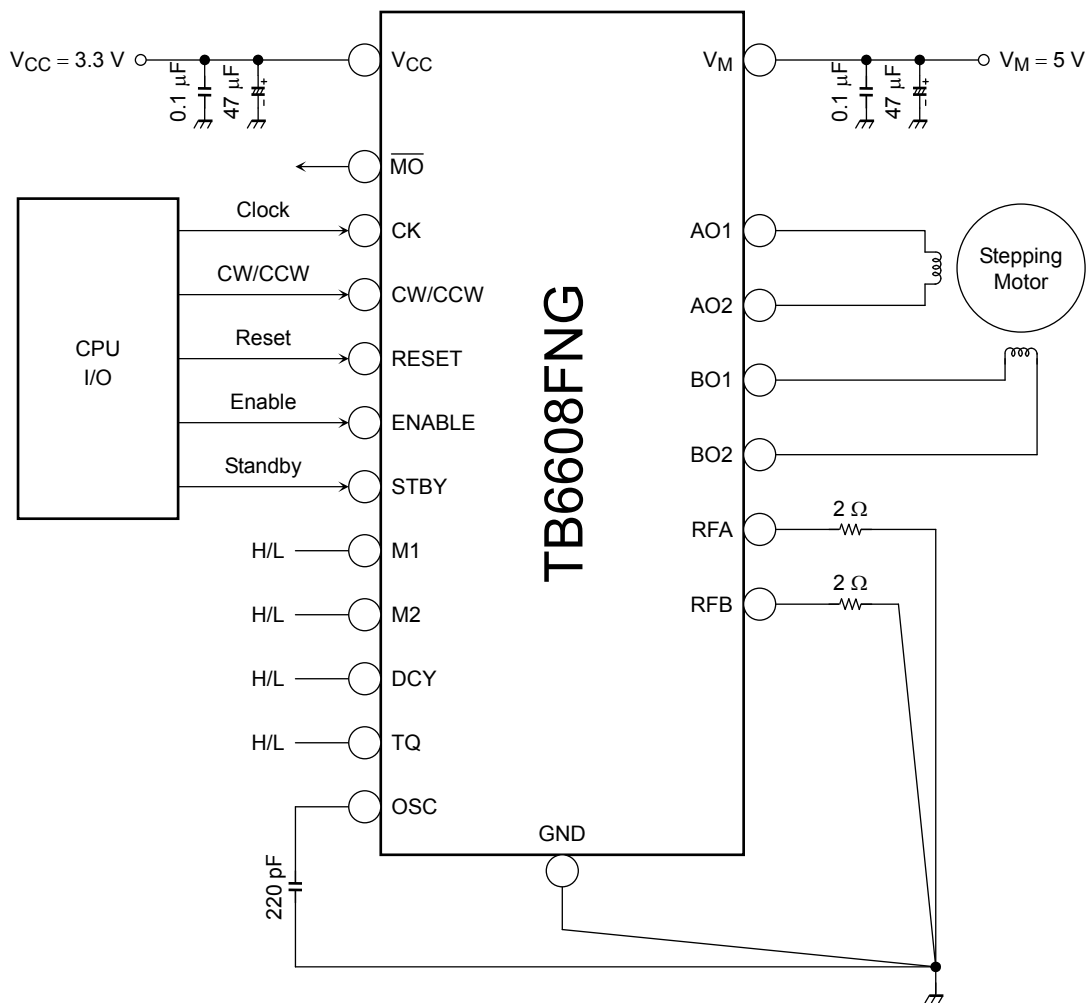

Note 1: Capacitors for the power supply lines should be connected as close to the IC as possible.

Note 2: The STBY pin must be set Low upon powering on and off the device. Otherwise, a large current might abruptly flow through the output pins.

Also, at the power-on, V_M must be applied after applying V_{CC} . At the power-off, V_{CC} must be turned off after turning off V_M .

Usage Considerations

A large current might abruptly flow through the IC in case of a short-circuit across its outputs, a short-circuit to power supply or a short-circuit to ground, leading to a damage of the IC. Also, the IC or peripheral parts may be permanently damaged or emit smoke or fire resulting in injury especially if a power supply pin (V_{CC} , V_M) or an output pin (AO1, AO2, BO1, BO2) is short-circuited to adjacent or any other pins.

These possibilities should be fully considered in the design of the output, V_{CC} , V_M and ground lines.

Install this IC correctly. If not, (e.g., installing it in the wrong position,) the IC may be damaged permanently.

Fuses should be connected to the power supply lines.

Package Dimensions

SSOP20-P-225-0.65A

Unit : mm

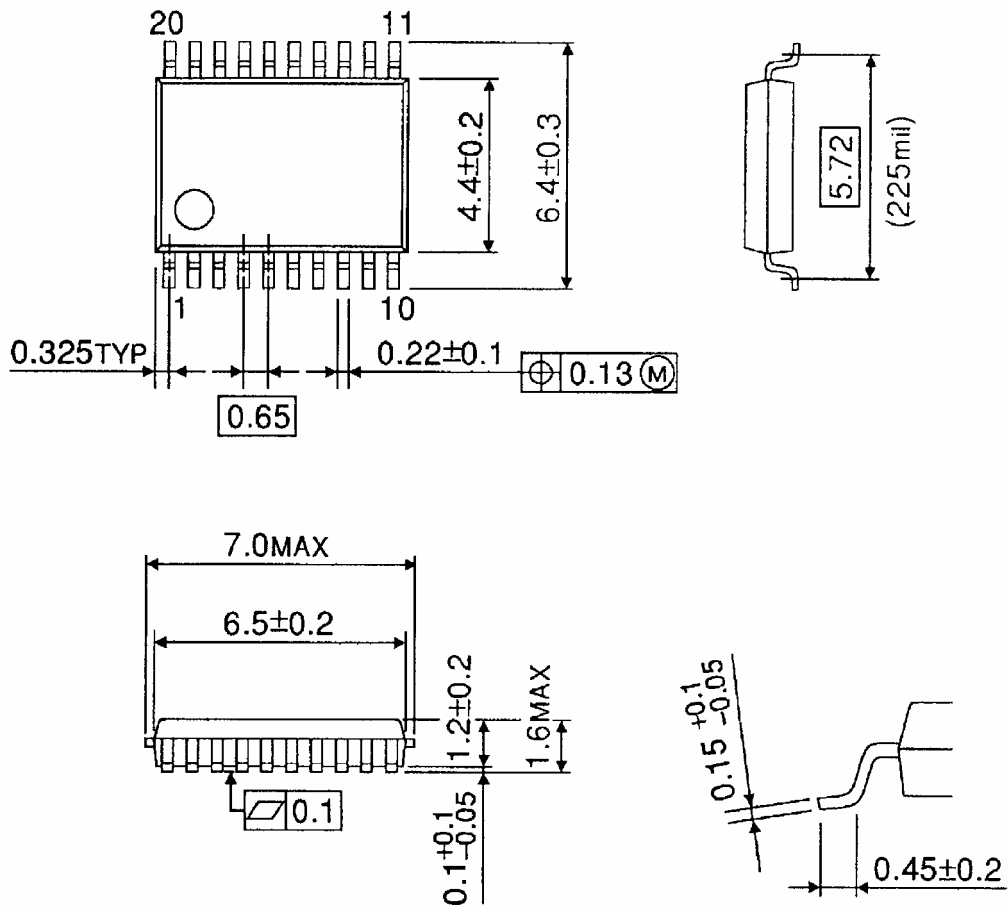

Weight: 0.09 g (typ.)

Notes on Contents

1. Block Diagrams

Some of the functional blocks, circuits, or constants in the block diagram may be omitted or simplified for explanatory purposes.

2. Equivalent Circuits

The equivalent circuit diagrams may be simplified or some parts of them may be omitted for explanatory purposes.

3. Timing Charts

Timing charts may be simplified for explanatory purposes.

4. Application Circuits

The application circuits shown in this document are provided for reference purposes only. Thorough evaluation is required, especially at the mass production design stage.

Toshiba does not grant any license to any industrial property rights by providing these examples of application circuits.

5. Test Circuits

Components in the test circuits are used only to obtain and confirm the device characteristics. These components and circuits are not guaranteed to prevent malfunction or failure from occurring in the application equipment.

IC Usage Considerations

Notes on Handling of ICs

- (1) The absolute maximum ratings of a semiconductor device are a set of ratings that must not be exceeded, even for a moment. Do not exceed any of these ratings.
Exceeding the rating(s) may cause the device breakdown, damage or deterioration, and may result injury by explosion or combustion.
- (2) Use an appropriate power supply fuse to ensure that a large current does not continuously flow in case of over current and/or IC failure. The IC will fully break down when used under conditions that exceed its absolute maximum ratings, when the wiring is routed improperly or when an abnormal pulse noise occurs from the wiring or load, causing a large current to continuously flow and the breakdown can lead smoke or ignition. To minimize the effects of the flow of a large current in case of breakdown, appropriate settings, such as fuse capacity, fusing time and insertion circuit location, are required.
- (3) If your design includes an inductive load such as a motor coil, incorporate a protection circuit into the design to prevent device malfunction or breakdown caused by the current resulting from the inrush current at power ON or the negative current resulting from the back electromotive force at power OFF. IC breakdown may cause injury, smoke or ignition.
Use a stable power supply with ICs with built-in protection functions. If the power supply is unstable, the protection function may not operate, causing IC breakdown. IC breakdown may cause injury, smoke or ignition.
- (4) Do not insert devices in the wrong orientation or incorrectly.
Make sure that the positive and negative terminals of power supplies are connected properly. Otherwise, the current or power consumption may exceed the absolute maximum rating, and exceeding the rating(s) may cause the device breakdown, damage or deterioration, and may result injury by explosion or combustion.
In addition, do not use any device that is applied the current with inserting in the wrong orientation or incorrectly even just one time.

Points to Remember on Handling of ICs

- (1) **Thermal Shutdown Circuit**
Thermal shutdown circuits do not necessarily protect ICs under all circumstances. If the thermal shutdown circuits operate against the over temperature, clear the heat generation status immediately. Depending on the method of use and usage conditions, such as exceeding absolute maximum ratings can cause the thermal shutdown circuit to not operate properly or IC breakdown before operation.
- (2) **Heat Radiation Design**
In using an IC with large current flow such as power amp, regulator or driver, please design the device so that heat is appropriately radiated, not to exceed the specified junction temperature (T_j) at any time and condition. These ICs generate heat even during normal use. An inadequate IC heat radiation design can lead to decrease in IC life, deterioration of IC characteristics or IC breakdown. In addition, please design the device taking into consideration the effect of IC heat radiation with peripheral components.
- (3) **Back-EMF**
When a motor rotates in the reverse direction, stops or slows down abruptly, a current flow back to the motor's power supply due to the effect of back-EMF. If the current sink capability of the power supply is small, the device's motor power supply and output pins might be exposed to conditions beyond maximum ratings. To avoid this problem, take the effect of back-EMF into consideration in system design.

RESTRICTIONS ON PRODUCT USE

070122EBA_R6

- The information contained herein is subject to change without notice. 021023_D
- TOSHIBA is continually working to improve the quality and reliability of its products. Nevertheless, semiconductor devices in general can malfunction or fail due to their inherent electrical sensitivity and vulnerability to physical stress. It is the responsibility of the buyer, when utilizing TOSHIBA products, to comply with the standards of safety in making a safe design for the entire system, and to avoid situations in which a malfunction or failure of such TOSHIBA products could cause loss of human life, bodily injury or damage to property.
In developing your designs, please ensure that TOSHIBA products are used within specified operating ranges as set forth in the most recent TOSHIBA products specifications. Also, please keep in mind the precautions and conditions set forth in the "Handling Guide for Semiconductor Devices," or "TOSHIBA Semiconductor Reliability Handbook" etc. 021023_A
- The TOSHIBA products listed in this document are intended for usage in general electronics applications (computer, personal equipment, office equipment, measuring equipment, industrial robotics, domestic appliances, etc.). These TOSHIBA products are neither intended nor warranted for usage in equipment that requires extraordinarily high quality and/or reliability or a malfunction or failure of which may cause loss of human life or bodily injury ("Unintended Usage"). Unintended Usage include atomic energy control instruments, airplane or spaceship instruments, transportation instruments, traffic signal instruments, combustion control instruments, medical instruments, all types of safety devices, etc. Unintended Usage of TOSHIBA products listed in this document shall be made at the customer's own risk. 021023_B
- The products described in this document shall not be used or embedded to any downstream products of which manufacture, use and/or sale are prohibited under any applicable laws and regulations. 060106_Q
- The information contained herein is presented only as a guide for the applications of our products. No responsibility is assumed by TOSHIBA for any infringements of patents or other rights of the third parties which may result from its use. No license is granted by implication or otherwise under any patents or other rights of TOSHIBA or the third parties. 070122_C
- Please use this product in compliance with all applicable laws and regulations that regulate the inclusion or use of controlled substances.
Toshiba assumes no liability for damage or losses occurring as a result of noncompliance with applicable laws and regulations. 060819_AF
- The products described in this document are subject to foreign exchange and foreign trade control laws. 060925_E