

Customer Information Sheet

DRAWING No.: M22-30500XX

SHEET 2 OF 2

IF IN DOUBT - ASK

(C)

NOT TO SCALE

THIRD ANGLE PROJECTION

ALL DIMENSIONS IN mm

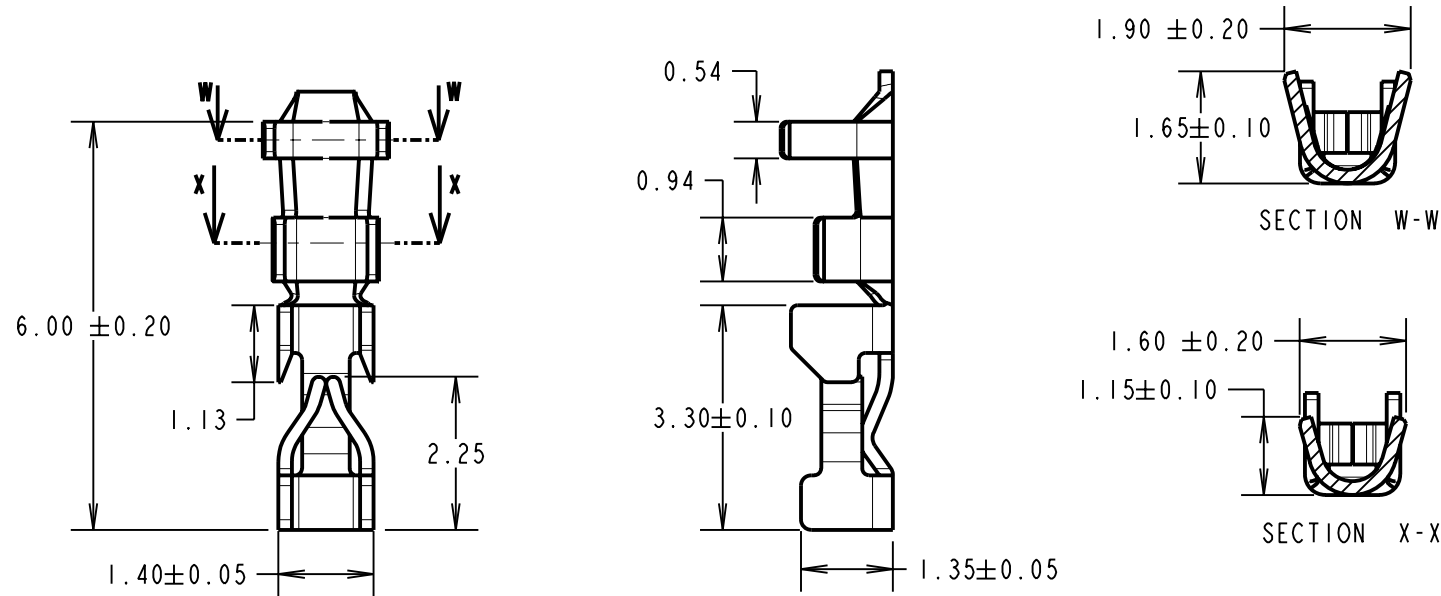

NOTES:

1. TO BE USED WITH CRIMP MOULDINGS M22-301XX00 OR M22-302XX00.
2. FOR HAND CRIMPING ONTO WIRE, USE HAND TOOL Z22-020 (INSTRUCTION SHEET IS-05), STRIP WIRE BY 1.0 - 1.5mm BEFORE CRIMPING.
3. SUITABLE FOR WIRE GAUGES 24-30 AWG.
4. CONTACTS SUPPLIED LOOSE IN QUANTITIES OF 100.

ORDER CODE:
M22-30500XX
 FINISH: _____
 42 = GOLD
 46 = 100% TIN

RA	9	09.06.10	10764
NAME	ISS.	DATE	C/NOTE
APPROVED:		R. ADDE	
CHECKED:		W. J. BOURNE	
DRAWN:		A. LIOTTA	
CUSTOMER REF.:			
ASSEMBLY DRG:			

HARWIN

HARWIN USA TEL: 603 893 5376 FAX: 603 893 5396 mis@harwin.com	HARWIN Europe (UK) TEL: 023 9231 4545 FAX: 023 9231 4590 mis@harwin.co.uk	HARWIN Asia TEL: +65 6 779 4909 FAX: +65 6 779 3868 mis@harwin.com.sg
--	--	--

THIS DRAWING AND ANY INFORMATION OR DESCRIPTIVE MATTER SET OUT HEREON ARE CONFIDENTIAL AND COPYRIGHT PROPERTY OF THE HARWIN GROUP AND MUST NOT BE DISCLOSED, LOANED, COPIED OR USED FOR MANUFACTURING, TENDERING OR FOR ANY OTHER PURPOSE WITHOUT THEIR WRITTEN PERMISSION.

TOLERANCES
 X. = ± 1 mm
 X.X = ± 0.25 mm
 X.XX = ± 0.10 mm
 X.XXX = ± 0.01 mm
 ANGLES = $\pm 5^\circ$
 UNLESS STATED

MATERIAL:
 PHOSPHOR BRONZE
FINISH: SEE ORDER CODE
S/AREA: mm²

TITLE:
 CRIMP CONTACT (LOOSE)
DRAWING NUMBER:
M22-30500XX
 SHT 2 OF 2