



Obsolescence Notice

This product is obsolete.

This information is available for your convenience only.

For more information on Zarlink's obsolete products and replacement product lists, please visit http://products.zarlink.com/obsolete_products/



EA-224 – 4-Port Fast Ethernet Access Controller (XpressFlow™ 2001 Series 10/100 Ethernet Switch Chipset)

1. DISTINCTIVE CHARACTERISTICS

- ◆ 4 independent 10/100Mbps Ethernet Access Ports
 - ◇ Direct interface with 10BaseT transceiver
 - ◇ IEEE 802.3u compliant MII (Media Independent Interface) and Serial Management interface
 - ◇ Direct interface with 100BaseTX, -T2, -T4, or -TF physical transceivers
- ◆ State of the art 0.5 micron 3.3Volt CMOS process
- ◆ 352-PIN BGA package
- ◆ Operating frequency
 - ◇ -33 33 MHz maximum
 - ◇ -40 40 MHz maximum
 - ◇ -50 50 MHz maximum
- ◆ 32-bit Local Buffer Memory Interface
 - ◇ Supports 128k to 1M bytes
 - ◇ Utilize high performance 32-bit Synchronous Burst SRAM
- ◆ Hardware assisted Buffer and Queue Management to minimized CPU overhead
- ◆ 16-bit Processor Bus I/O Interface
 - ◇ Allows host to access Control Registers & Local Buffer Memory
 - ◇ Supports Big and Little Endian CPUs
 - ◇ Direct interface with various different standard microprocessors including 386, 486 families and Motorola MPC series embedded processors.
- ◆ 32-bit XpressFlow Bus Interface
 - ◇ Uses Granule for frame transferring between Access Controllers
- ◆ Supports unicast, multicast, and broadcast frames
 - ◇ Also detects IEEE 802.3X MAC Control frames
- ◆ Works together with SC-201 XpressFlow Engine
 - ◇ Capable to forward frames at full line-rate
 - ◇ Distributed Flow Caching™ to reduce frame forwarding latency
- ◆ Supports both Half & Full Duplex operation
- ◆ Programmable Flow Control Enable
 - ◇ Jam Fake Collision for Half Duplex Mode
 - ◇ Transmit Flow Control Frame for IEEE 802.3x Full Duplex Mode

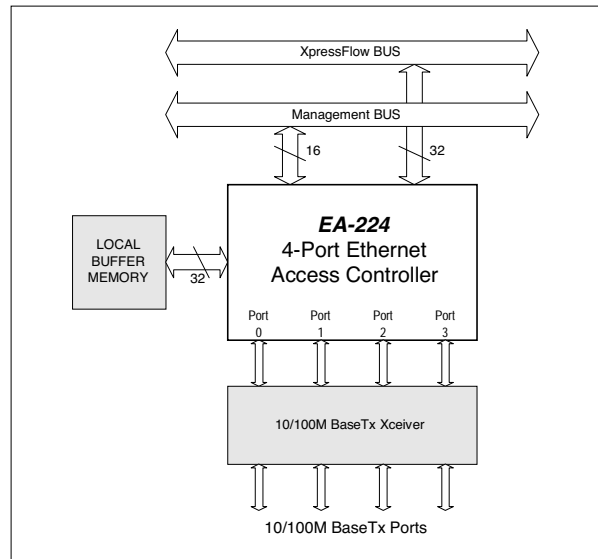

- ◆ Three frame forwarding modes
 - ◇ Store-&-Forward
 - ◇ Safe Cut-Thru (Runt Free)
 - ◇ Turbo Cut-Thru (10Mbps Mode only)
 - ◇ Automatically selects the optimized mode for forwarding
 - ◇ Allows manual frame forwarding mode selection override
- ◆ Multi-Media ready with QoS supports
 - ◇ Four frame transmission priority queues
- ◆ Complies with IEEE 802.1 Bridge Standard
 - ◇ Assigns one unique MAC Address for each port
- ◆ VLAN ID Tagging & Stripping
 - ◇ Auto padding if necessary after stripping
- ◆ Automatic retry frame transmission
 - ◇ Transmit collision
 - ◇ Transmit buffer under-run
- ◆ Automatic receive filtering for bad frames for Store & Forward Mode
 - ◇ Bad FCS
 - ◇ Short events or frames under 64 bytes
 - ◇ Long events or frames over 1518 bytes
- ◆ Automatic statistic collection for RMON

2. GENERAL DESCRIPTION:

The EA-224 provides four 10/100Mbps Ethernet network access interface ports. MII interface is used to connect external PHY devices for 100 Mbps Ethernet. They also can direct connect with standard 10Mbps serial interface.

The EA-224 provides the Ethernet MAC protocols, handles the local buffer memory interface and management, arbitrates among multiple priority queues, and interfaces with the XpressFlow Engine and other Access Controllers through the XpressFlow message passing protocol.

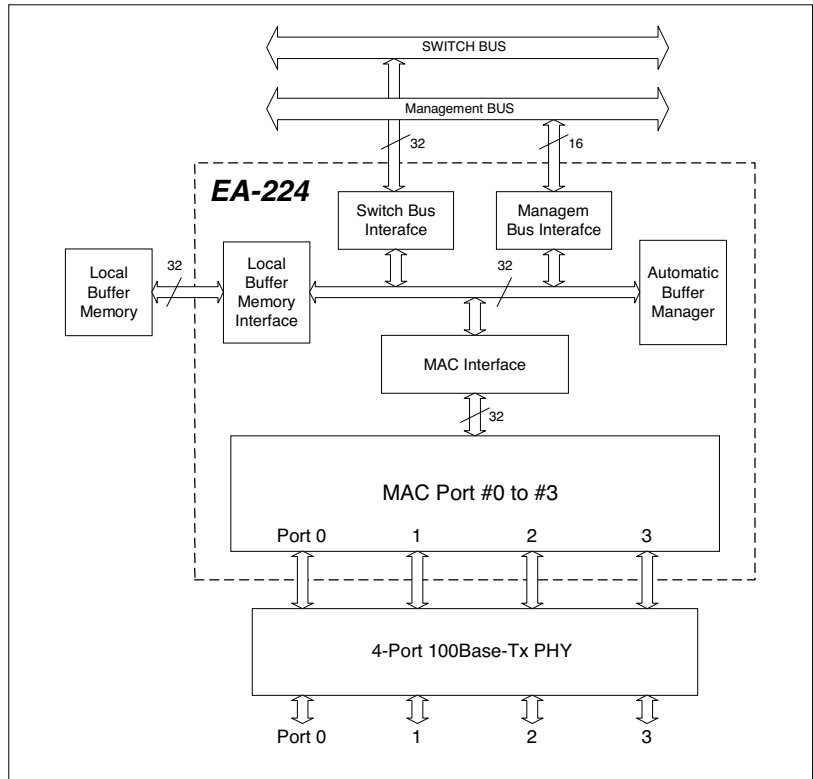

**Block Diagram –
EA-224 4-Port Ethernet Access Controller**

2.1 Related Components:

- ◆ **SC-201** – XpressFlow Engine
- ◆ **EA-208E** – 8-port 10Mbps Ethernet Access Controller
- ◆ **EA-208** – 6-port 10 + 2-port 10/100 Ethernet Access Controller
- ◆ **EA-222** – 2-port 10/100 Fast Ethernet Access Controller

2.2 Typical Application:

- ◆ A 16-port Ethernet Switch with 4 Fast Ethernet Up-Links

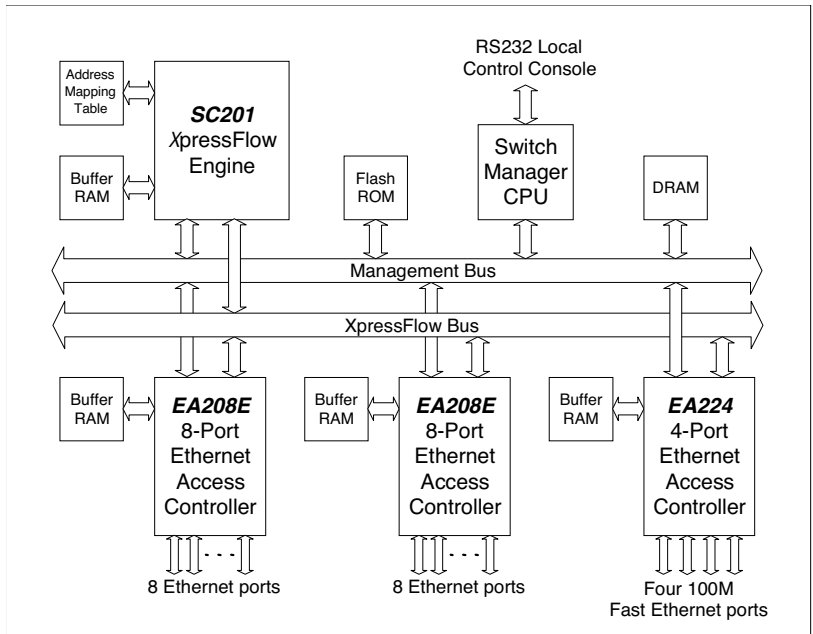

**System Block Diagram --
16-Port Ethernet Switch with 4 Fast Ethernet Up-Links**

3. PIN ASSIGNMENT

3.1 Logic Symbol

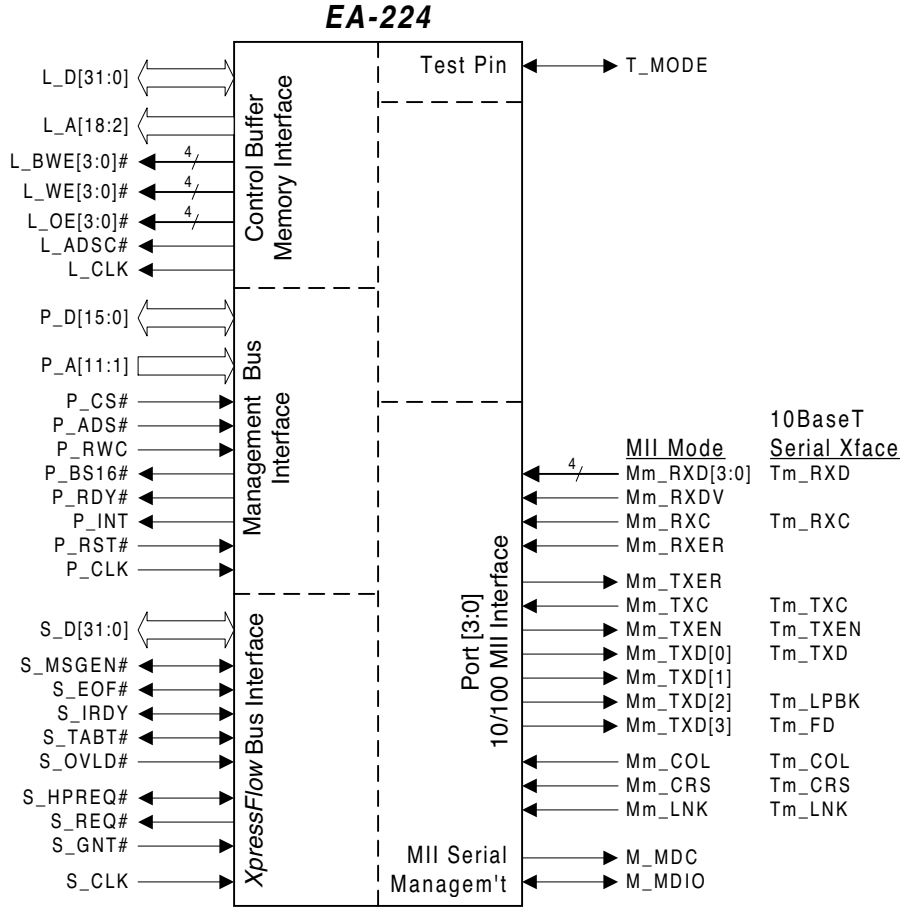

3.2 Pin Assignment (Preliminary)

Note:	#	Active low signal
	Input	Input signal
	I-ST	Input signal with Schmitt-Trigger
	Output	Output signal (Tri-State driver)
	Out-OD	Output signal with Open-Drain driver
	I/O-TS	Input & Output signal with Tri-State driver
	I/O-OD	Input & Output signal with Open-Drain driver
	5VT	Input with 5V Tolerance
	①	Output signal with programmable polarity.
	②	Input or output pins with weak internal pull up resistors (50k to 100k Ohms each)
	③	These pins are reserved for internal use only. They should be left unconnected.

Pin No(s).	Symbol	Type	Max I _{OL} / I _{OH}	Name & Functions
Management Bus Interface				
J25,K26,L24,K25,L26, M24,L25,M26,N24,M25, P24,N26,N25,R24,P26, P25	P_D[15:0]	TTL I/O-TS (5VT)	16mA	Management Bus – Data Bit [15:0]
C26,D24,C25,E24,D26, D25,F24,E26,E25,G24, F26	P_A[11:1]	TTL In (5VT)		Management Bus – Address Bit [11:1]
F25	P_ADS#	TTL In (5VT)		Management Bus – Address Strobe
H25	P_RWC	TTL In (5VT)		Management Bus – Read/Write Control
J24	P_RDY#	TTL Out-OD	16mA	Management Bus – Data Ready
G25	P_BS16#	TTL Out-OD	16mA	Management Bus – 16 bit Data Bus
G26	P_CS#	TTL In (5VT)		Management Bus – Chip Select
H26	P_INT ①	CMOS Output	4mA	Management Bus – Interrupt Request
J26	P_RST#	TTL In-ST (5VT)		Management Bus – Master Reset
K24	P_CLK	TTL In (5VT)		Management Bus – Bus Clock
XpressFlow Bus Interface				
C23,A23,B22,C22,A22	S_D[31:27] / P_C[0:4]	CMOS I/O-TS	12 mA	XpressFlow Bus – Data Bit [31:27] or Management Bus Interface Configuration bit [0:4]
B21,D20,C21,A21,B20, A20,C20,B19,A19,C19, B18,A18,B17,C18,A17, D17,B16,C17,A16,B15, A15,C16,B14,D15,A14, C15,B13	S_D[26:0]	CMOS I/O-TS	12mA	XpressFlow Bus – Data Bit [26:0]
B12	S_MSGEN#	CMOS I/O-TS	12 mA	XpressFlow Bus – Message Envelope
A12	S_EOF#	CMOS I/O-TS	12mA	XpressFlow Bus – End of Frame
C14	S_IRDY	CMOS I/O-TS	12 mA	XpressFlow Bus – Initiator Ready
C13	S_TABT#	CMOS I/O-OD	12 mA	XpressFlow Bus – Target Abort
B23	S_HPREQ#	CMOS I/O-OD	12mA	XpressFlow Bus – High Priority Request
A24	S_REQ#	CMOS Output	4mA	XpressFlow Bus – Bus Request to SC201
B24	S_GNT#	CMOS Input		XpressFlow Bus – Bus Grant from SC201
A13	S_OVLD#	CMOS Input		XpressFlow Bus – Bus Overload
D13	S_CLK	CMOS Input		XpressFlow Bus – Clock

**XpressFlow-2001 Series –
Ethernet Switch Chip-set****EA-224
4-Port 10/100M Ethernet Access Controller**

Pin No(s).	Symbol	Type	Max I _{OL} / I _{OH}	Name & Functions
Control Buffer Memory Interface				
M4,N2,L3,M1,M2,L1,K3, L2,K4,K1,J3,K2,J1,J2, H3,H1,H2,G3,G1,G2,F1, F3,F2,E1,E3,E2,D1,D3, D2,C1,C2,B1	L_D[31:0]	TTL I/O-TS ②	8mA	Local Memory Bus – Data Bit [31:0]
A6,B6,C8,A7,D8,D7,C9, A8,B8,A9,C10,B9,D10, A10,C11,B10,A11	L_A[18:2]	CMOS Output	8mA	Local Memory Bus – Address Bit [17:2]
C7	L_A[19] / L_OE[3]#	CMOS Output	8mA	Local Memory Bus – Address Bit [19] or Memory Read Chip Select [3]
D5,A5,A3	L_OE[2:0]#	CMOS Output	2mA	Local Memory Read Chip Select [2:0]
D7,E4,B5,C4	L_WE[3:0]#	CMOS Output	2mA	Local Memory Write Chip Select [3:0]
C6,B4,A4,C5	L_BWE[3:0]#	CMOS Output	8mA	Local Memory Byte Write Enable, Byte [3:0]
B3	L_ADSC#	CMOS Output	8mA	Local Memory Controller Address Status
G4	L_CLK	CMOS Output	8mA	Local Memory Clock input
Fast Ethernet Access Port [3:0]				
T24	M_MDC	CMOS Output	4mA	MII Management Data Clock – (common for all MII Ports – Port [1:0])
R26	M_MDIO	TTL IO-TS (5VT)	4mA	MII Management Data I/O – (common for all MII Ports – Port [1:0])
AB2,U25,AE26,AF5	M[3:0]_RXD[3]	TTL In (5VT) ②		Port [3:0] – MII Receive Data Bit [3]
AB1,V24,AD25,AE6	M[3:0]_RXD[2]	TTL In (5VT) ②		Port [3:0] -- Receive Data Bit [2]
AA3,U26,AD26,AD6	M[3:0]_RXD[1]	TTL In (5VT) ②		Port [3:0] -- Receive Data Bit [1]
AC2,T25	M[3:2]_RXD[0]	TTL In (5VT) ②		Port [3:0] -- Receive Data Bit [0]
AC25,AF6	M[1:0]_RXD[0]	TTL In (5VT)		
Y3,V26,AF24,AD5	M[3:0]_RXDV	TTL In (5VT) ②		Port [3:0] -- Receive Data Valid
AC1,U24	M[3:2]_RXC	TTL In (5VT) ②		Port [3:0] -- Receive Clock
AC24,AE7	M[1:0]_RXC	TTL In (5VT)		
AA1,V25,AD23,AE5	M[3:0]_RXER			Port [3:0] -- Receive Error
AA2,W24,AE24,AF4	M[3:0]_TXER	CMOS Output	4mA	Port [3:0] -- Transmit Error
W2,AA25,AE22,AD1	M[3:0]_TXC	TTL In (5VT)		Port [3:0] -- Transmit Clock
W1,AA24,AF22,AF2	M[3:0]_TXEN	CMOS Output	4mA	Port [3:0] -- Transmit Enable
V3,AA26,AD21,AE3	M[3:0]_TXD[3]	CMOS Output	4mA	Port [3:0] -- Transmit Data Bit [3]
Y2,Y26,AE23,AF3	M[3:0]_TXD[2]	CMOS Output	4mA	Port [3:0] -- Transmit Data Bit [2]
W3,W26,AD22,AD4	M[3:0]_TXD[1]	CMOS Output	4mA	Port [3:0] -- Transmit Data Bit [1]
Y1,W25,AF23,AE4	M[3:0]_TXD[0]	CMOS Output	4mA	Port [3:0] -- Transmit Data Bit [0]
V1,AB26	M[3:2]_COL	TTL In (5VT) ②		Port [3:0] -- Collision Detected
AD20,AC3	M[1:0]_COL	TTL In (5VT)		
U3,AB24	M[3:2]_CRS	TTL In (5VT) ②		Port [3:0] -- Carrier Sense
AF21,AD2	M[1:0]_CRS	TTL In (5VT)		
V2,AB25	M[3:2]_LNK ①	TTL In (5VT) ②		Port [3:0] -- Link Status
AE21,AB3	M[1:0]_LNK ①	TTL In (5VT)		
Test Facility				
A25	T_MODE	CMOS I/O-TS ②	2mA	Test Pin – Set Test Mode upon Reset, and provides test status output during test mode
N1,M3,P2,P1,N3,R2,P3, R1,T2,R3,T1,R4,U2,T3, U1,U4	T_D[15:10] ③	CMOS Output	4mA	Test Pins – Reserved for internal use only

**XpressFlow-2001 Series –
Ethernet Switch Chip-set**

**EA-224
4-Port 10/100M Ethernet Access Controller**

Pin No(s).	Symbol	Type	Name & Functions
Power Pins			
D6,D11,D16,D21,F4, F23,L4,L23,T4,T23,AA4, AA23,AC6,AC11,AC16, AC21	VDD	Power	+3.3 Volt DC Supply
A1,A2,A26,B2,B25,B26, C3,C24,D4,D9,D14,D19, D23,H4,J23,N4,P23,V4, W23,AC4,AC8,AC13, AC18,AC23,AD3,AD24, AE1,AE2,AE25,AF1, AF25	VSS	Power	Ground

**XpressFlow-2001 Series –
Ethernet Switch Chip-set**

**EA-224
4-Port 10/100M Ethernet Access Controller**

3.3 Pin Reference Table: (352 pin BGA)

Pin #	Signal Name	Pin #	Signal Name	Pin #	Signal Name	Pin #	Signal Name	Pin #	Signal Name
F26	P_A[1]	D17	S_D[11]	D2	L_D[3]	AF23	M1_TXD[0] / T1_TXD	R1	T_D[8]
G24	P_A[2]	A17	S_D[12]	D3	L_D[4]	AF22	M1_TXEN / T1_TXEN	P3	T_D[9]
E25	P_A[3]	C18	S_D[13]	D1	L_D[5]	AE22	M1_TXC / T1_TXC	R2	T_D[10]
E26	P_A[4]	B17	S_D[14]	E2	L_D[6]	AE24	M1_TXER	N3	T_D[11]
F24	P_A[5]	A18	S_D[15]	E3	L_D[7]	AD23	M1_RXER	P1	T_D[12]
D25	P_A[6]	B18	S_D[16]	E1	L_D[8]	AC24	M1_RXC / T1_RXC	P2	T_D[13]
D26	P_A[7]	C19	S_D[17]	F2	L_D[9]	AF24	M1_RXDV	M3	T_D[14]
E24	P_A[8]	A19	S_D[18]	F3	L_D[10]	AC25	M1_RXD[0] / T1_RXD	N1	T_D[15]
C25	P_A[9]	B19	S_D[19]	F1	L_D[11]	AD26	M1_RXD[1]		
D24	P_A[10]	C20	S_D[20]	G2	L_D[12]	AD25	M1_RXD[2]	D6	VDD
C26	P_A[11]	A20	S_D[21]	G1	L_D[13]	AE26	M1_RXD[3]	D11	VDD
F25	P_ADS#	B20	S_D[22]	G3	L_D[14]	AB25	M2_LNK / T2_LNK	D16	VDD
G26	P_CS#	A21	S_D[23]	H2	L_D[15]	AB24	M2_CRS / T2_CRS	D21	VDD
H25	P_RWC	C21	S_D[24]	H1	L_D[16]	AB26	M2_COL / T2_COL	F4	VDD
G25	P_BS16#	D20	S_D[25]	H3	L_D[17]	AA26	M2_TXD[3] / T2_FD	F23	VDD
J24	P_RDY#	B21	S_D[26]	J2	L_D[18]	Y26	M2_TXD[2] / T2_LPBK	L4	VDD
J26	P_RST#	A22	S_D[27] / P_C[4]	J1	L_D[19]	W26	M2_TXD[1]	L23	VDD
H26	P_INT	C22	S_D[28] / P_C[3]	K2	L_D[20]	W25	M2_TXD[0] / T2_TXD	T4	VDD
K24	P_CLK	B22	S_D[29] / P_C[2]	J3	L_D[21]	AA24	M2_TXEN / T2_TXEN	T23	VDD
P25	P_D[0]	A23	S_D[30] / P_C[1]	K1	L_D[22]	AA25	M2_TXC / T2_TXC	AA4	VDD
P26	P_D[1]	C23	S_D[31] / P_C[0]	K4	L_D[23]	W24	M2_TXER	AA23	VDD
R24	P_D[2]			L2	L_D[24]	V25	M2_RXER	AC6	VDD
N25	P_D[3]	A11	L_A[2]	K3	L_D[25]	U24	M2_RXC / T2_RXC	AC11	VDD
N26	P_D[4]	B10	L_A[3]	L1	L_D[26]	V26	M2_RXDV	AC16	VDD
P24	P_D[5]	C11	L_A[4]	M2	L_D[27]	T25	M2_RXD[0] / T2_RXD	AC21	VDD
M25	P_D[6]	A10	L_A[5]	M1	L_D[28]	U26	M2_RXD[1]	A1	GND
N24	P_D[7]	D10	L_A[6]	L3	L_D[29]	V24	M2_RXD[2]	A2	GND
M26	P_D[8]	B9	L_A[7]	N2	L_D[30]	U25	M2_RXD[3]	A26	GND
L25	P_D[9]	C10	L_A[8]	M4	L_D[31]	V2	M3_LNK / T3_LNK	B2	GND
M24	P_D[10]	A9	L_A[9]			U3	M3_CRS / T3_CRS	B25	GND
L26	P_D[11]	B8	L_A[10]	T24	M_MDC	V1	M3_COL / T3_COL	B26	GND
K25	P_D[12]	A8	L_A[11]	R26	M_MDIO	V3	M3_TXD[3] / T3_FD	C3	GND
L24	P_D[13]	C9	L_A[12]			Y2	M3_TXD[2] / T3_LPBK	C24	GND
K26	P_D[14]	B7	L_A[13]	AB3	M0_LNK / T0_LNK	W3	M3_TXD[1]	D4	GND
J25	P_D[15]	D8	L_A[14]	AD2	M0_CRS / T0_CRS	Y1	M3_TXD[0] / T3_TXD	D9	GND
		A7	L_A[15]	AC3	M0_COL / T0_COL	W1	M3_TXEN / T3_TXEN	D14	GND
D13	S_CLK	C8	L_A[16]	AE3	M0_TXD[3] / T0_FD	W2	M3_TXC / T3_TXC	D19	GND
A13	S_OVLD#	B6	L_A[17]	AF3	M0_TXD[2] / T0_LPBK	AA2	M3_TXER	D23	GND
B23	S_HPREQ#	A6	L_A[18]	AD4	M0_TXD[1]	AA1	M3_RXER	H4	GND
A24	S_REQ#	C7	L_A[19] / OE[3]#	AE4	M0_TXD[0] / T0_TXD	AC1	M3_RXC / T3_RXC	J23	GND
B24	S_GNT#	D5	L_OE[2]#	AF2	M0_TXEN / T0_TXEN	Y3	M3_RXDV	N4	GND
B12	S_MSGEN#	A5	L_OE[1]#	AD1	M0_TXC / T0_TXC	AC2	M3_RXD[0] / T3_RXD	P23	GND
A12	S_EOF#	A3	L_OE[0]	AF4	M0_TXER	AA3	M3_RXD[1]	V4	GND
C14	S_IRDY	D7	L_WE[3]#	AE5	M0_RXER	AB1	M3_RXD[2]	W23	GND
C13	S_TABT#	E4	L_WE[2]#	AE7	M0_RXC / T0_RXC	AB2	M3_RXD[3]	AC4	GND
B13	S_D[0]	B5	L_WE[1]#	AD5	M0_RXDV			AC8	GND
C15	S_D[1]	C4	L_WE[0]#	AF6	M0_RXD[0] / T0_RXD	A25	T_MODE	AC13	GND
A14	S_D[2]	C6	L_BWE[3]#	AD6	M0_RXD[1]			AC18	GND
D15	S_D[3]	B4	L_BWE[2]#	AE6	M0_RXD[2]	U4	T_D[0]	AC23	GND
B14	S_D[4]	A4	L_BWE[1]#	AF5	M0_RXD[3]	U1	T_D[1]	AD3	GND
C16	S_D[5]	C5	L_BWE[0]#	AE21	M1_LNK / T1_LNK	T3	T_D[2]	AD24	GND
A15	S_D[6]	B3	L_ADSC#	AF21	M1_CRS / T1_CRS	U2	T_D[3]	AE1	GND
B15	S_D[7]	G4	L_CLK	AD20	M1_COL / T1_COL	R4	T_D[4]	AE2	GND
A16	S_D[8]	B1	L_D[0]	AD21	M1_TXD[3] / T1_FD	T1	T_D[5]	AE25	GND
C17	S_D[9]	C2	L_D[1]	AE23	M1_TXD[2] / T1_LPBK	R3	T_D[6]	AF1	GND
B16	S_D[10]	C1	L_D[2]	AD22	M1_TXD[1]	T2	T_D[7]	AF25	GND

- Note:**
- ① Output signals with programmable polarity.
 - ② Input or output pins with weak internal pull up resistors (50k to 100k Ohms each)
 - ③ These pins are reserved for internal use only. They should be left unconnected.

4. FUNCTIONAL DESCRIPTION

4.1 Local Memory (Local Buffer Memory) Interface

- ◆ Use industry standard Synchronous Burst Mode SRAM up to 1M bytes
 - ◇ 32k x 32, 64k x 32, 128k x 32, or 256k x 32
- ◆ Provides 4 individual *Byte Write Enable* controls (L_BWE[3:0]#)
- ◆ Provides separate Read and Write Chip Selects (L_OE[3:0]# and L_WE[3:0]#) for each memory chip
- ◆ Supports back to back Read or Write operations across memory chips

4.1.1 Pin Description

Symbol	Type	Name & Functions
L_D[31:0] ②	TTL I/O-TS	Local Memory Data Bus Bit [31:0] – a 32-bit synchronous data bus.
L_A[18:2]	CMOS Output	Local Memory Address Bus Bit [18:2] – Bit [18:2] of a synchronous address bus. The memory address is sampled when L_CS# is enabled and L_ADSC# is asserted.
L_A[19] / L_OE[3]#	CMOS Output	Local Memory Address Bus Bit [19] or Local Memory Read Chip Select [3] – Depends on memory configuration, this pin can be used as the Local Memory Address Bit [19] or as the Local Memory Read Chip Select [3].
L_OE[2:0]#	CMOS Output	Local Memory Read Chip Select [2:0] – allows up to read one of the 4 banks of memory.
L_WE[3:0]#	CMOS Output	Local Memory Write Chip Select [3:0] – allows up to write one of the 4 banks of memory.
L_BWE[3:0]#	CMOS Output	Local Memory Byte Write Enable [3:0] – use to write individual bytes.
L_ADSC#	CMOS Output	Local Memory Controller Address Status – to load a new address.
L_CLK	CMOS Output	Local Memory Clock – a synchronous clock to memory devices.

Note: ② These pins have weak internal pull up resistors (50k to 100k Ohms each).

4.1.2 Supported Memory Configurations

RAM Chip Size	# of RAM Chips	Total Buffer Memory Size	Read/Write Chip Select and High Address Bits							
			Chip #3		Chip #2		Chip #1		Chip #0	
			L_WE[3]#	L_A[19] / L_OE[3]#	L_WE[2]#	L_OE[2]#	L_WE[1]#	L_OE[1]#	L_WE[0]#	L_OE[0]#
32k x 32	1	128k bytes	----	----	----	----	----	----	L_WE[0]#	L_OE[0]#
	2	256k bytes	----	----	----	----	L_WE[1]#	L_OE[1]#	L_WE[0]#	L_OE[0]#
	4	512k bytes	L_WE[3]#	L_OE[3]#	L_WE[2]#	L_OE[2]#	L_WE[1]#	L_OE[1]#	L_WE[0]#	L_OE[0]#
64k x 32	1	256k bytes	----	----	----	----	----	----	L_WE[0]#	L_OE[0]#
	2	512k bytes	----	----	----	----	L_WE[1]#	L_OE[1]#	L_WE[0]#	L_OE[0]#
	4	1M bytes	L_WE[3]#	L_OE[3]#	L_WE[2]#	L_OE[2]#	L_WE[1]#	L_OE[1]#	L_WE[0]#	L_OE[0]#
128k x32	1	512k bytes	----	----	----	----	----	----	L_WE[0]#	L_OE[0]#
	2	1M bytes	----	----	----	----	L_WE[1]#	L_OE[1]#	L_WE[0]#	L_OE[0]#
256k x32	1	1M bytes	----	L_A[19]	----	----	----	----	L_WE[0]#	L_OE[0]#

4.1.3 Bus Cycle Waveforms

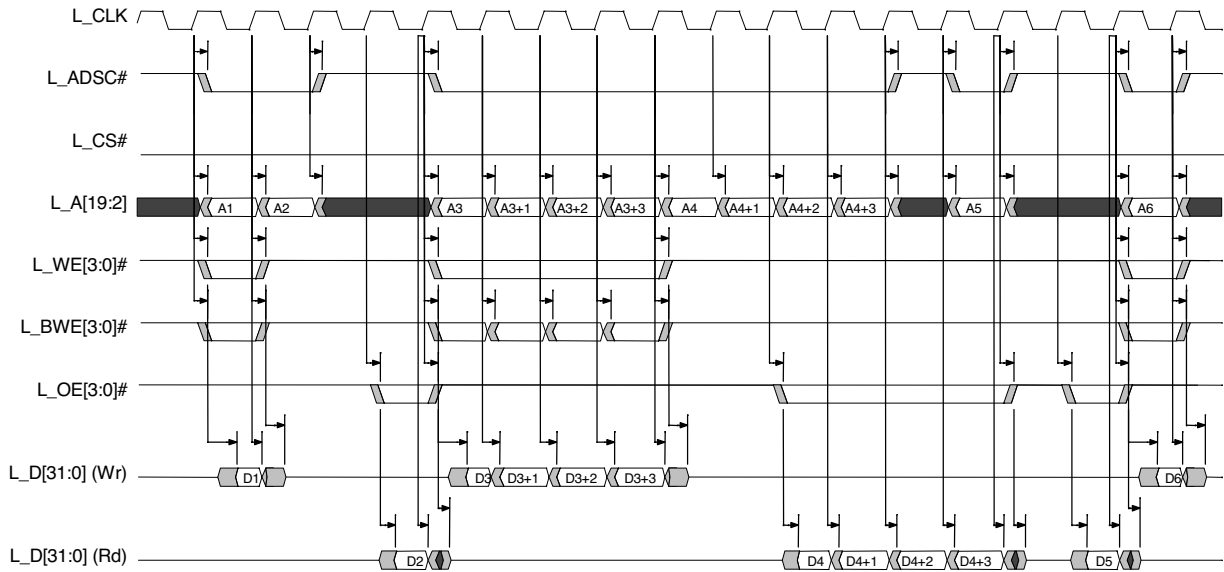

Typical Local Memory Access Operations

4.2 Management Bus Interface

- ◆ Supports various industry standard micro-processors including:
 - ◇ Intel 186, 386, and 486 family or equivalent
 - ◇ Motorola MPC series embedded processors
- ◆ Easily adapts to other industry standard CPUs
- ◆ Provides separate Address and Data bus
- ◆ Supports Big & Little Endian byte ordering
- ◆ Supports 16-bit Data Bus
- ◆ Supports early RDY cycle
 - ◇ Meets timing requirement for Intel/AMD 186 family processors
- ◆ Supports 1X or 2X CPU Clock
 - ◇ 2X CPU Clock for 386 family processors
- ◆ Provides a single interrupt signal to Switch Manager CPU

4.2.1 Pin Description

Symbol	Type	Name & Functions																								
P_C[4:0]	CMOS Input	<p>Processor Configuration bit [4:0]: – During the Reset Cycle, the P_C[4:0] pins provides the processor configuration. By using external weak pull-up or -down resistors, they define the External Management Bus Interface Configuration. These inputs are sampled at the trailing edge of the Reset cycle.</p> <p>C[0] – Defines the CPU Clock input is 1X or 2X clock C[1] – Selects either Big or Little Endian byte ordering C[2] – Defines the polarity of the P_RWC (Rd/Wr Control) input C[3] – Defines the CPU Bus width – For EA-208, it is default to 16-bit CPU Bus interface, and the setting of this bit is ignored. C[4] – Defines the timing relationship between P_RDY and P_D[15:0] valid. If C[4] is High, the P_D[15:0] are valid along in the same clock period as P_RDY is asserted. If C[4] is Low, the P_RDY is asserted one clock period <u>early</u> ahead of the P_D[15:0] are valid.</p> <table border="1" style="margin-left: 20px;"> <thead> <tr> <th></th> <th>C[0]</th> <th>C[1]</th> <th>C[2]</th> <th>C[3]</th> <th>C[4]</th> </tr> <tr> <th></th> <th>CPU Clock</th> <th>Byte Order</th> <th>RWC</th> <th>Bus Size</th> <th>RDY Timing</th> </tr> </thead> <tbody> <tr> <td>Lo</td> <td>1X Clock</td> <td>Little Endian</td> <td>P_R/W#</td> <td>n/a</td> <td>Normal</td> </tr> <tr> <td>Hi</td> <td>2x Clock</td> <td>Big Endian</td> <td>P_W/R#</td> <td>n/a</td> <td>Early</td> </tr> </tbody> </table> <p>After RESET, these pins are used as XpressFlow Bus Data bit [31:27].</p>		C[0]	C[1]	C[2]	C[3]	C[4]		CPU Clock	Byte Order	RWC	Bus Size	RDY Timing	Lo	1X Clock	Little Endian	P_R/W#	n/a	Normal	Hi	2x Clock	Big Endian	P_W/R#	n/a	Early
	C[0]	C[1]	C[2]	C[3]	C[4]																					
	CPU Clock	Byte Order	RWC	Bus Size	RDY Timing																					
Lo	1X Clock	Little Endian	P_R/W#	n/a	Normal																					
Hi	2x Clock	Big Endian	P_W/R#	n/a	Early																					
P_A[11:1]	TTL In (5VT)	Address Bus Bit [11:1] – I/O port address																								
P_D[15:0]	TTL I/O-TS (5VT)	Data Bus Bit [15:0] – a 16-bit synchronous data bus.																								
P_ADS#	TTL In (5VT)	Address Strobe – indicates valid address is on the bus																								
P_RWC	TTL Input (5VT)	Read/Write Control – indicates the current bus cycle is a read or write cycle. C[1] defines the polarity of this signal during the Reset cycle. C[1]=0 P_R/W# is used for PowerPC or other similar processors. C[1]=1 P_W/R# is used for 386, 486 or other similar processors																								
P_RDY#	TTL Out-OD	Data Ready – timing indicates for bus data valid																								
P_BS16#	TTL Out-OD	Bus Size 16 – response to bus master that the EA208 only supports 16-bit data bus width.																								
P_CS#	TTL Input (5VT)	Chip Select – indicates the XpressFlow Engine is the target for the current bus operation.																								
P_INT ①	CMOS Output	Interrupt Request to Switch Manager CPU <i>The polarity of this signal output is programmable via chip configuration register.</i>																								
P_RST#	TTL In-ST (5VT)	CPU Reset – Synchronous reset Input from Switch Manager CPU																								
P_CLK	TTL In (5VT)	CPU Clock – 2X Clock for 386 family, and 1X Clock for the others																								

4.2.2 Motorola MPC801 Processor Interface

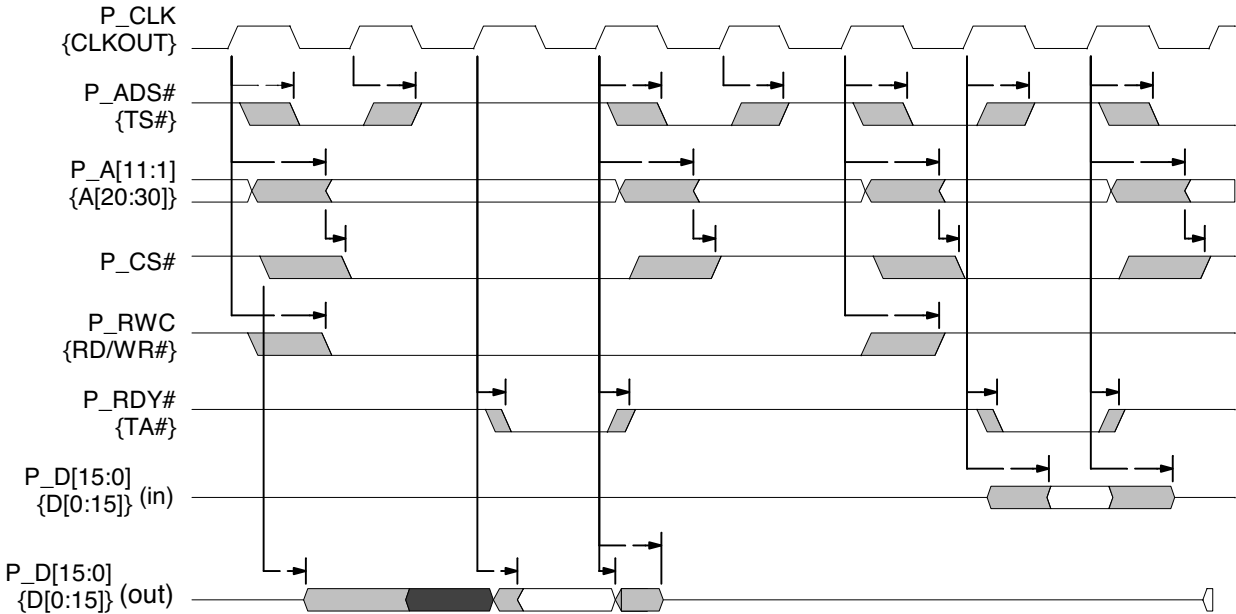

Note: Mnemonics with in {} are the equivalent signals defined by MPC801

Typical Motorola MPC801 CPU I/O Access Operations

4.2.3 Intel 486 Processor Interface

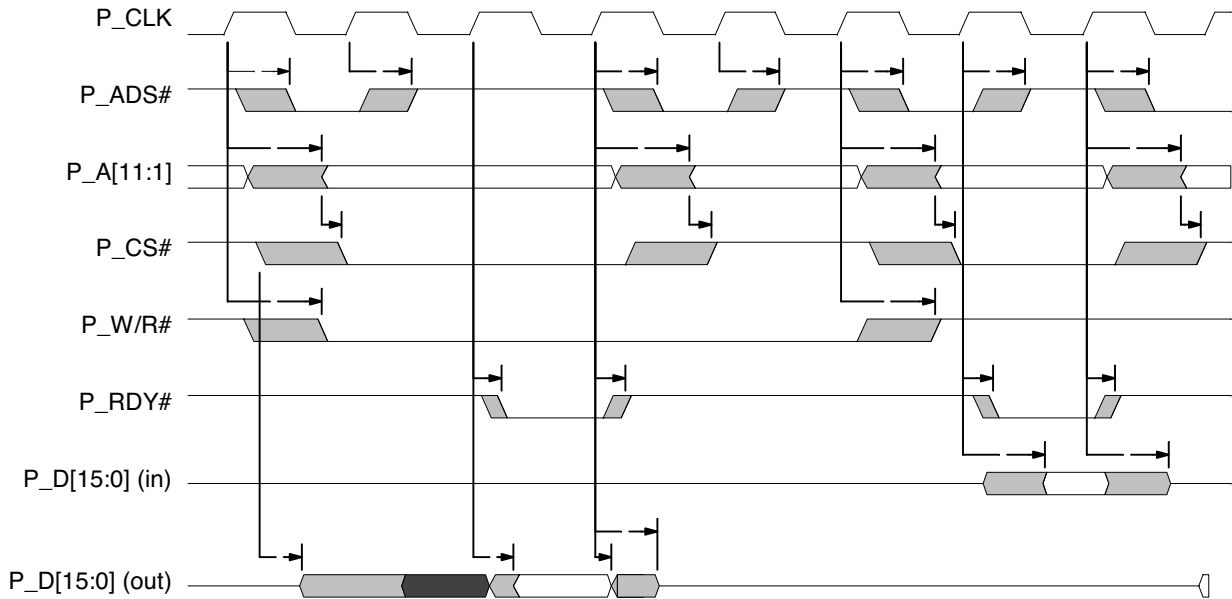

Typical 486 CPU I/O Access Operations

4.2.4 Intel 386 Processor Interface

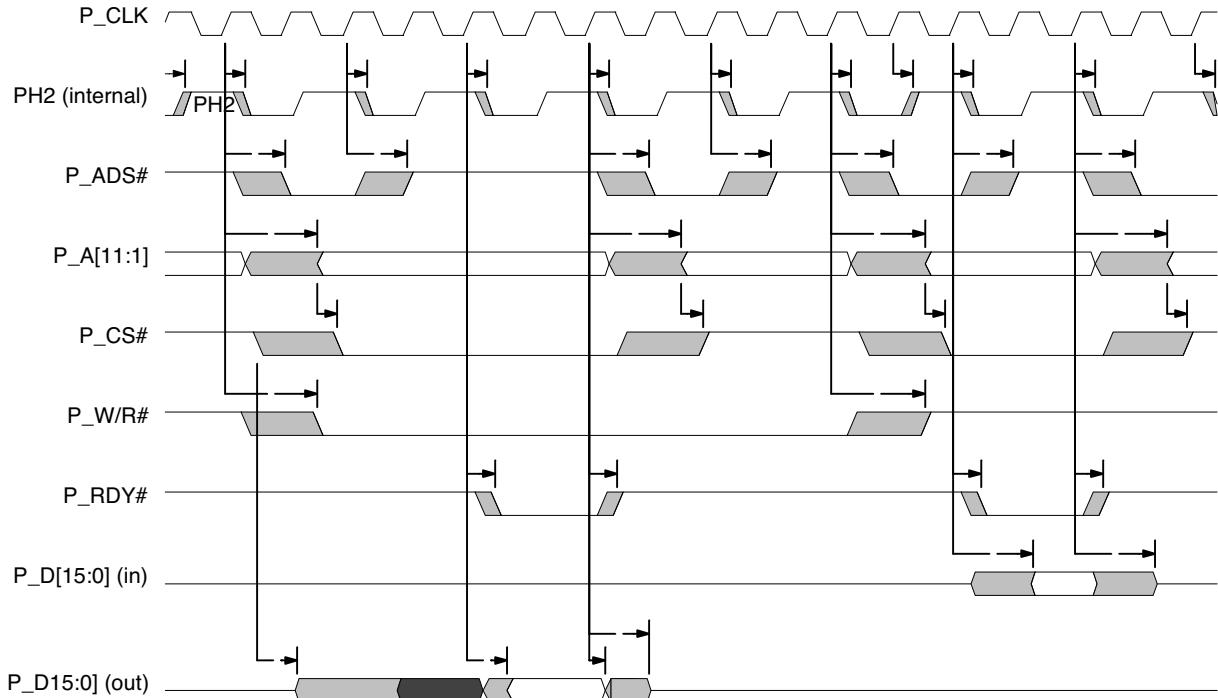

Typical 386 CPU I/O Access Operations

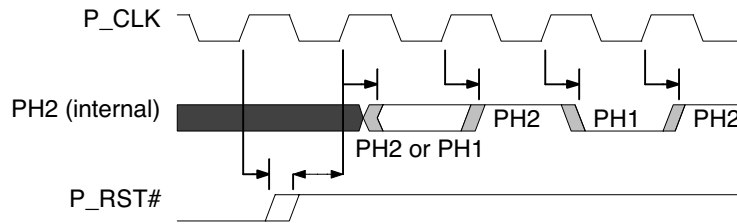

Internal PH2 Clock Synchronization **

Note: ** See Intel 386 Processor Data Book for more details

4.2.5 Register Map

Note: All 32-bit registers are D-word aligned.

All 16-bit registers are also D-word aligned and right justified.

For the Little Endian CPUs, register offset bit [1,0] are always set to be 00.

For the Big Endian CPUs, register offset bit [1,0] are always set to be 10.

- ① This is a Global Register. CPU is allowed to write the Global Register of all devices by a single operation.
- ② These registers are reserved for system diagnostic usage only.

Register	Description	I/O Offset		Reg. Size	W/R	Note:
		Little Endian	Big Endian			
Device Configuration Registers (DCR)						
GCR	Global Control Register	hF00	hF02	16-bit	W/--	①
DCR0	Device Status Register	hF00	hF02	16-bit	--/R	
DCR1	Signature & Revision Register	hF10	hF12	16-bit	--/R	
DCR2	ID Register	hF20	hF22	16-bit	W/R	
DCR3	Device Configuration Register	hF30	hF32	16-bit	W/R	
DCR4	Interfaces Status Register	hF40	hF42	16-bit	--/R	
DTSR	Test Register	hF70	hF72	16-bit	W/R	
Interrupt Controls						
ISR	Interrupt Status Register – Unmasked	hF80	hF82	16-bit	--/R	
ISRM	Interrupt Status Register – Masked	hF90	hF92	16-bit	--/R	
IMSK	Interrupt Mask Register	hFA0	hFA2	16-bit	W/R	
IAR	Interrupt Acknowledgment Register	hFB0	hFB2	16-bit	W/--	
Buffer Memory Interface						
MWAR	Memory Write Address Reg. – Single Cycle	hE08	hE08	32-bit	W/R	
MRAR	Memory Read Address Reg. – Single Cycle	hE18	hE18	32-bit	W/R	
MBAR	Memory Address Register – Burst Mode	hE28	hE28	32-bit	W/R	
MWBS	Memory Write Burst Size (in D-words)	hE40	hE42	16-bit	W/R	
MRBS	Memory Read Burst Size (in D-words)	hE50	hE52	16-bit	W/R	
MWDR	Memory Write Data Register	hE68	hE68	32-bit	W/--	
MWDX	Memory Write Data Reg. – Byte Swapping	hE6C	hE6C	32-bit	W/--	
MRDR	Memory Read Data Register	hE68	hE68	32-bit	--/R	
MRDX	Memory Read Data Reg. – Byte Swapping	hE6C	hE6C	32-bit	--/R	
FCB Buffer & Stack Management						
FCBBA	Frame Control Buffer – Base Address	hD00	hD02	16-bit	W/R	
FCBAG	Frame Control Buffer – Buffer Aging Status	hD30	hD32	16-bit	--/R	②
FCBSL	Frame Ctrl Buffer Stack – Size Limit	hD90	hD92	16-bit	W/R	
FCBST	Frame Ctrl Buffer Stack – Buffer Low Threshold	hDA0	hDA2	16-bit	W/R	
FCBSS	Frame Ctrl Buffer Stack – Allocation Status	hDB0	hDB2	16-bit	--/R	②

Register	Description	I/O Offset		Reg. Size	W/R	Note:
		Little Endian	Big Endian			
Access Control Function (Chip Level controls)						
AVXR	VLAN Control Table (VCT) Index Register	hC00	hC02	16-bit	W/--	
AVDR	VCT Data Register	hC10	hC12	16-bit	W/R	
AVTC	VLAN Type Code	hC20	hC22	16-bit	W/R	
AXSC	Transmission Scheduling Control Register	hC30	hC32	16-bit	W/R	
AMIIC	MII Command Register	hC40	hC40	32-bit	W/--	
AMIIS	MII Status Register	hC40	hC40	32-bit	--/R	
AFCR	Flow Control Register	hC70	hC72	16-bit	W/R	
AMAR0	Multicast Address. for MAC Control Frames Byte [1,0]	hC80	hC82	16-bit	W/R	
AMAR1	Byte [3,2]	hC90	hC92	16-bit	W/R	
AMAR2	Byte [5,4]	hCA0	hCA2	16-bit	W/R	
AMCT	MAC Control FrameType Code Register	hCB0	hCB2	16-bit	W/R	
ADAR0	Base MAC Address Register – Byte [1,0]	hCC0	hCC2	16-bit	W/R	
ADAR1	Base MAC Address Register – Byte [3,2]	hCD0	hCD2	16-bit	W/R	
ADAR2	Base MAC Address Register – Byte [5,4]	hCE0	hCE2	16-bit	W/R	
Ethernet MAC Port Control Registers – (substitute [n] with Port Number, n = {0..3})						
ECR0	MAC Port Control Register	hn00	hn02	16-bit	W/R	
ECR1	MAC Port Configuration Register	hn10	hn12	16-bit	W/R	
ECR2	MAC Port Interrupt Mask Register	hn20	hn22	16-bit	W/R	
ECR3	MAC Port Interrupt Status Register	hn30	hn32	16-bit	--/R	
EXSR	MAC Tx Status Register	hn40	hn42	16-bit	--/R	②
EXEC	MAC Tx Error Counters	hn50	hn52	16-bit	--/R	②
ERSR	MAC Rx Status Register	hn68	hn68	32-bit	--/R	②
EREC	MAC Rx Error Counters	hn78	hn78	32-bit	--/R	②

4.3 XpressFlow Bus Operation

- ◆ Zarlink's optimized XpressFlow Bus architecture
- ◆ Provides up to 1.6G bps switching bandwidth
 - ◇ -33 1.07G bps
 - ◇ -40 1.28G bps
 - ◇ -50 1.60G bps
- ◆ Full multi bus master structure
- ◆ Allows Access Controllers to communicate with XpressFlow Engine and other Access Controllers via a message passing protocol
- ◆ Two level bus request priorities
 - ◇ High priority for Data Messages
 - ◆ for forwarding an Ethernet frame from receiving port to transmission port
 - ◇ Low priority for Command Messages
 - ◆ for passing control information between devices

4.3.1 Pin Description

Symbol	Type	Name & Functions
S_D[31:0]	CMOS I/O-TS	Data Bus Bit [31:0] – a 32-bit synchronous data bus. Note: During the system RESET period, Data Bit [31:27] are used as Processor Interface Configuration bit [0:3]
S_MSGEN#	CMOS I/O-TS	Message Envelope – encompasses the entire period of a message transfer. Targets use the leading edge of this signal to detect the beginning of a message transfer, and to decode the message header for the intended target(s).
S_EOF#	CMOS I/O-TS	End of Frame – only used by frame data transfer messages to identify the end of frame condition. This signal is synchronous with the Rx Frame Status word appended to the end of the message.
S_IRDY	CMOS I/O-TS	Initiator Ready – a normal true signal. When negated, it indicates the initiator had asserted wait state(s) in between command words. Target should use this signal as enable signal for latching the data from the bus.
S_TABT#	CMOS I/O-OD	Target Abort – when asserted, the target had aborted the reception of current message on the bus.
S_HPREQ#	CMOS I/O-OD	High Priority Request – indicates one or more Bus Requester is requesting for high priority message transfer.
S_REQ#	CMOS Output	Bus Request – Bus Request signal from Access Controller to Bus Access Arbitrator in XpressFlow Engine
S_GNT#	CMOS Input	Bus Grant – Bus Grant signal from Bus Arbitrator to Bus Requester
S_OVLD#	CMOS Input	Bus Over-load – when asserted, all data forwarding bus bandwidth has been allocated. Cannot support additional load for data forwarding traffic.
S_CLK	CMOS Input	XpressFlow Bus Clock – up to 50MHz system clock

4.3.2 Bus Cycle Waveforms

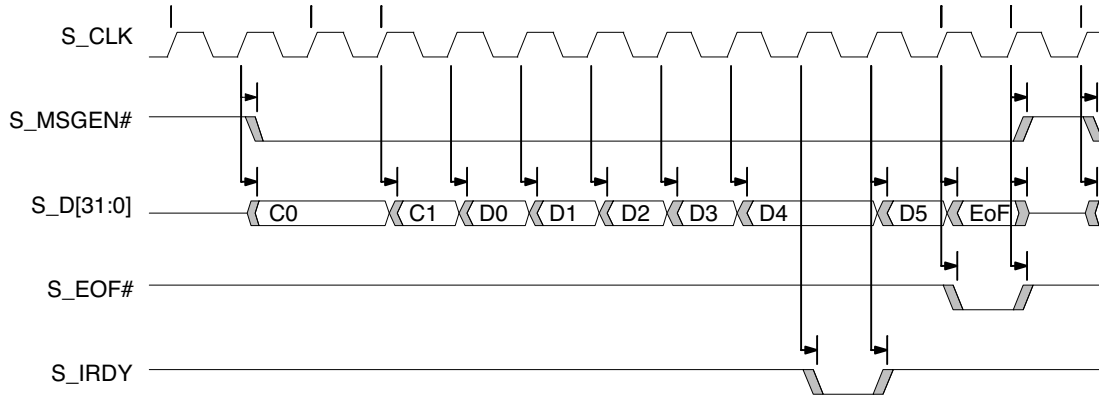

XpressFlow Bus Data Transfer Cycle

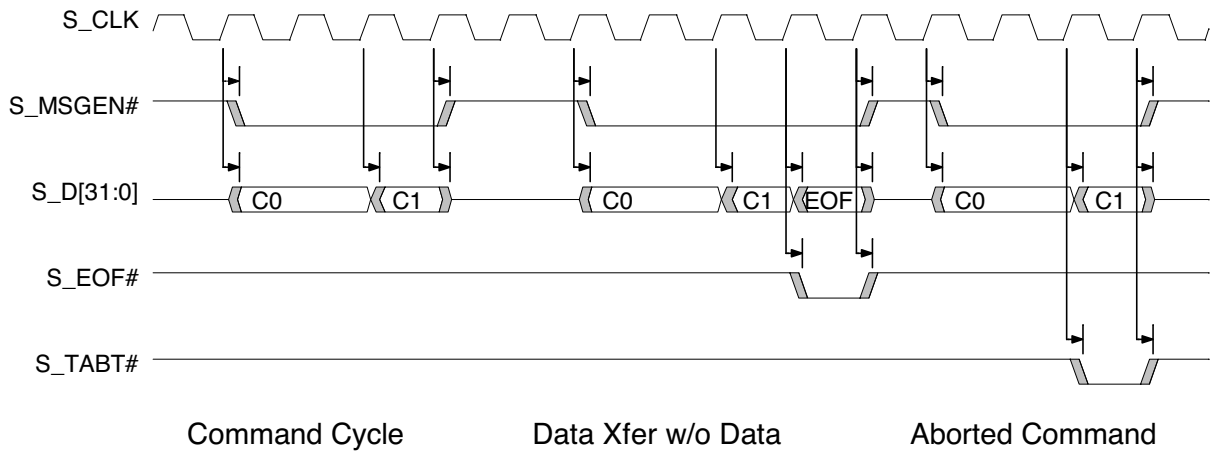

Other XpressFlow Bus Cycles

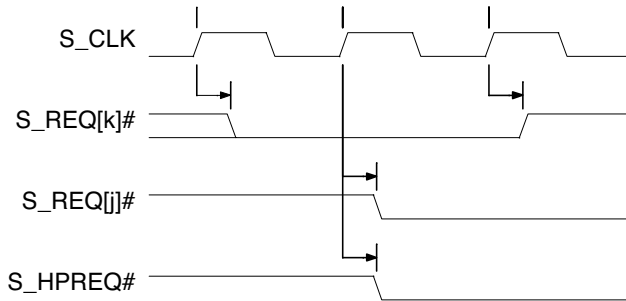

High Priority Request pre-empts the low priority request.

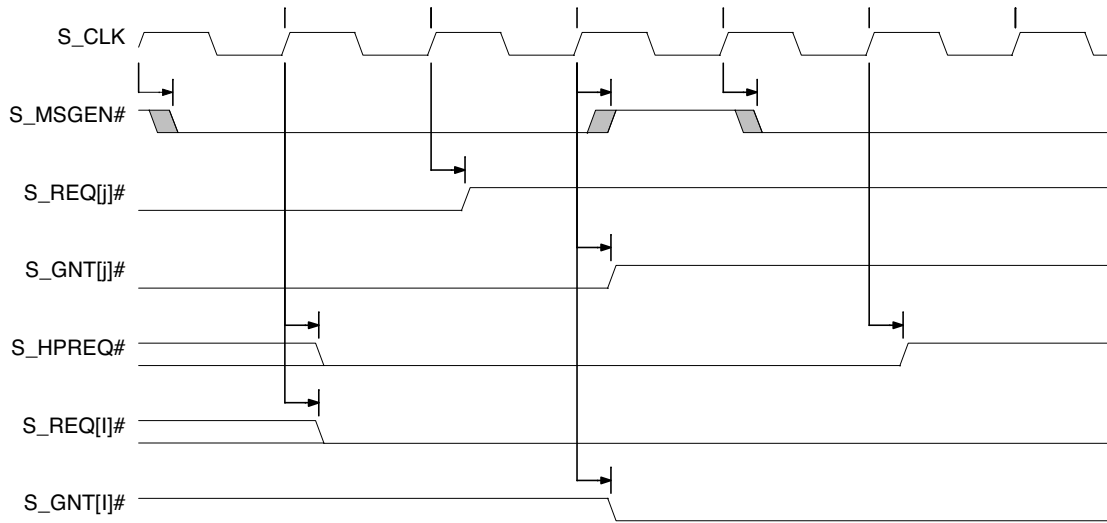

XpressFlow Bus arbitration

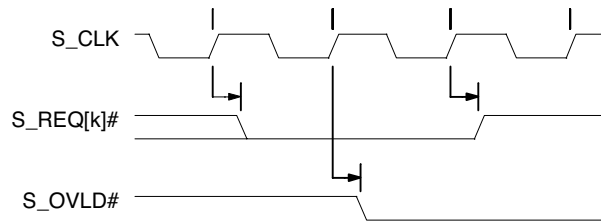

Bus Overload pre-empts the data transfer request

4.4 MII Interface

- ◆ Fully compliant with IEEE 802.3u Media Independent Interface for connecting with external 10/100M Ethernet Physical Layer Transceiver
- ◆ Supports both 10Mbps 10BaseT interface and 100Mbps 100BaseTx interface
- ◆ Supports both half and full duplex operation
- ◆ Shared Station Management interface (one for all MII channels with in the Access Controller)
- ◆ All ports can also support 10Mbps Serial Interface
 - ◇ If 10Mbps Serial Interface is used, the MII port pin assignment are re-mapped for 10Mbps Serial Interface.

4.4.1 Pin Description

Symbol	Type	Name & Functions
M_MDC	CMOS Output	MII Management Data Clock – (common for all MII Ports) used to synchronize the MII data stream (MDIO) for transferring between the Access Controller and the MII Transceivers.
M_MDIO	TTL IO-TS (5VT)	MII Management Data I/O – (common for all MII Ports) a serial management data stream synchronous with MDC.
Mm_RXD[3:0]	TTL In (5VT)	Receive Data [3:0] – (one set for each MII Port) a four-bit transmit data nibble. Bit 0 is the least significant bit, and bit 3 is the most significant bit.
Mm_RXDV	TTL In (5VT)	Receive Data Valid – (one for each MII Port) instructs the MAC to begin moving data nibbles from the receive data lines.
Mm_RXC	TTL In (5VT)	Receive Clock – (one for each MII Port) a 25MHz clock input with 35% to 65% duty cycles.
Mm_RXER	TTL In (5VT)	Receive Error – (one for each MII Port)
Mm_TXER	CMOS Output	Transmit Error – (one for each MII Port)
Mm_TXC	TTL In (5VT)	Transmit Clock – (one for each MII Port) a continuous clock input with 35% to 65% duty cycles.
Mm_TXEN	CMOS Output	Transmit Enable – (one for each MII Port) instructs the transceiver to begin moving data nibbles on the transmit data lines.
Mm_TXD[3:0]	CMOS Output	Transmit Data [3:0] – (one set for each MII Port) a four-bit transmit data nibble. Bit 0 is the least significant bit, and bit 3 is the most significant bit.
Mm_COL	TTL In (5VT)	Collision Detected – (one for each MII Port)
Mm_CRS	TTL In (5VT)	Carrier Sense – (one for each MII Port)
Mm_LNK ①	TTL In (5VT)	Link Status – (one for each MII Port) The polarity of this signal is programmable via Port Configuration Register

Note: “m” is the port number [3:0].

① These signals have programmable output polarity.

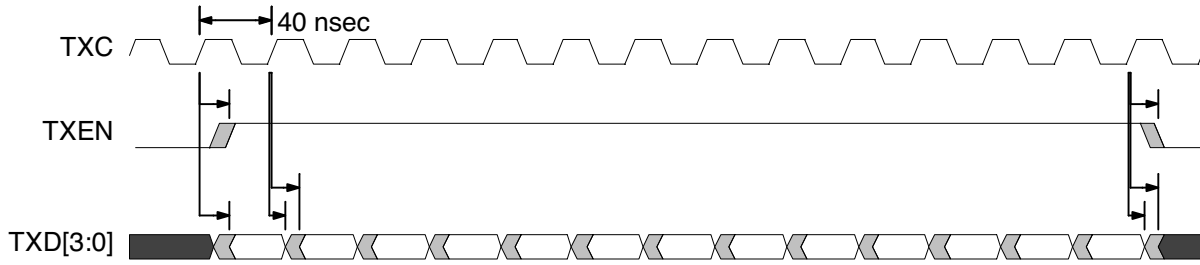

100M MII Transmit Timing

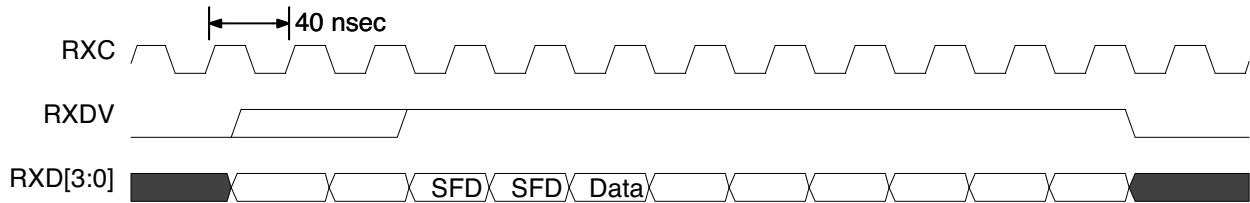

100M MII Receive Timing

4.4.2 PIN Mapping between MII Interface and 10Mbps Serial Interface

MII Interface		10Mbps Serial Interface		
Symbol	Type	Symbol	Type	Name & Functions
Mm_RXD[3:1]	TTL In (5VT)			Not used by Serial Interface Ports. <i>Has a weak internal pull-up resistor.</i>
Mm_RXD[0]	TTL In (5VT)	Tm_RXD	TTL In (5VT)	Receive Data – (one for each Serial Interface Port) a receive data stream.
Mm_RXDV	TTL In (5VT)			Not used by Serial Interface Ports. <i>Has a weak internal pull-up resistor.</i>
Mm_RXC	TTL In (5VT)	Tm_RXC	TTL In (5VT)	Receive Clock – (one for each Serial Interface Port)
Mm_RXER	TTL In (5VT)			Not used by Serial Interface Ports. <i>Has a weak internal pull-up resistor.</i>
Mm_TXER	CMOS Output			Not used by Serial Interface Ports.
Mm_TXC	TTL In (5VT)	Tm_TXC	TTL In (5VT)	Transmit Clock – (one for each Serial Interface Port) a continuous clock input with 35% to 65% duty cycles.
Mm_TXEN	CMOS Output	Tm_TXEN	CMOS Output	Transmit Enable – (one for each Serial Interface Port)
Mm_TXD[0]	CMOS Output	Tm_TXD	CMOS Output	Transmit Data – (one for each Serial Interface Port) a transmit data stream.
Mm_TXD[1]	CMOS Output			Not used by Serial Interface Ports
Mm_TXD[2]	CMOS Output	Tm_LPBK ①	CMOS Output	Loop Back Enable – (one for each Serial Interface Port) <i>The polarity of this signal is programmable via Port Configuration Register</i>
Mm_TXD[3]	CMOS Output	Tm_FD ①	CMOS Output	Full Duplex Mode – (one for each Serial Interface Port) <i>The polarity of this signal is programmable via Port Configuration Register</i>
Mm_COL	TTL In (5VT)	Tm_COL	TTL In (5VT)	Collision Detected – (one for each Serial Interface Port)
Mm_CRS	TTL In (5VT)	Tm_CRS	TTL In (5VT)	Carrier Sense – (one for each Serial Interface Port)
Mm_LNK ①	TTL In (5VT)	Tm_LNK ①	TTL In (5VT)	Link Status – (one for each Port) <i>The polarity of this signal is programmable via Port Configuration Register</i>

Note: “m” is the port number [3:0].

① These signals have programmable output polarity.

4.5 Test Facility

Symbol	Type	Name & Functions
T_MODE	CMOS I/O TS	Test Mode Selection & Test Output – Set Test Mode upon Reset, and provides test status output during test mode

5. DC SPECIFICATION

5.1 ABSOLUTE MAXIMUM RATINGS

Storage Temperature	-65°C to +150°C
Operating Temperature	0°C to +70°C
Supply Voltage V_{DD} with Respect to V_{SS}	+3.0 V to +3.6 V
Voltage on 5V Tolerant Input Pins	-0.5 V to ($V_{DD} + 2.5$ V)
Voltage on Other Pins	-0.5 V to ($V_{DD} + 0.5$ V)

Stresses above those listed may cause permanent device failure. Functionality at or above these limits is not implied. Exposure to Absolute Maximum Ratings for extended periods may affect device reliability.

5.2 DC CHARACTERISTICS

$V_{DD} = +3.0$ V to +3.6 V $T_{AMBIENT} = 0^{\circ}$ C to +70°C

Symbol	Parameter Description	Preliminary			Unit
		Min	Typ	Max	
f_{osc}	Frequency of Operation (-33)	20		33.3333	MHz
	Frequency of Operation (-40)	20		40.0000	MHz
	Frequency of Operation (-50)	20		50.0000	MHz
I_{DD}	Supply Power – @ 33.3333 MHz ($V_{DD}=3.3$ V)			TBD	mA
	Supply Power – @ 40 MHz ($V_{DD}=3.3$ V)			TBD	mA
	Supply Power – @ 50 MHz ($V_{DD}=3.3$ V)			TBD	mA
$V_{OH-CMOS}$	Output High Voltage (CMOS) $I_{OH} = \text{maximum}$	$V_{DD} - 0.5$			V
$V_{OL-CMOS}$	Output Low Voltage (CMOS) $I_{OL} = \text{maximum}$			0.45	V
V_{OH-TTL}	Output High Voltage (TTL) $I_{OH} = \text{maximum}$	2.4			V
V_{OL-TTL}	Output Low Voltage (TTL) $I_{OL} = \text{maximum}$			0.45	V
$V_{IH-CMOS}$	Input High Voltage (CMOS)	$V_{DD} \times 70\%$		$V_{DD} + 10\%$	V
$V_{IL-CMOS}$	Input Low Voltage (CMOS)	-0.5		$V_{DD} \times 30\%$	V
V_{IH-TTL}	Input High Voltage (TTL)	2.0		$V_{DD} + 10\%$	V
V_{IL-TTL}	Input Low Voltage (TTL)	-0.3		+0.8	V
V_{IH-5VT}	Input High Voltage (TTL 5V tolerant)	2.0		$V_{DD} + 1.8$	V
V_{IL-5VT}	Input Low Voltage (TTL 5V tolerant)	-0.3		+0.8	V
I_{LI}	Input Leakage Current (0.1 V $\leq V_{IN} \leq V_{DD}$) (all pins except those with internal pull-up/pull-down resistors)			± 10	μ A
I_{LO}	Output Leakage Current (0.1 V $\leq V_{OUT} \leq V_{DD}$)			± 15	μ A
I_{IH}	Input Leakage Current $V_{IH} = V_{DD} - 0.1$ V (pins with internal pull-down resistors)			60	μ A
I_{IL}	Input Leakage Current $V_{IL} = 0.1$ V (pins with internal pull-up resistors)			-60	μ A
C_{IN}	Input Capacitance		8		pF
C_{OUT}	Output Capacitance		8		pF
$C_{I/O}$	I/O Capacitance		10		pF

Notes:

6. AC SPECIFICATION

6.1 XpressFlow Bus Interface:

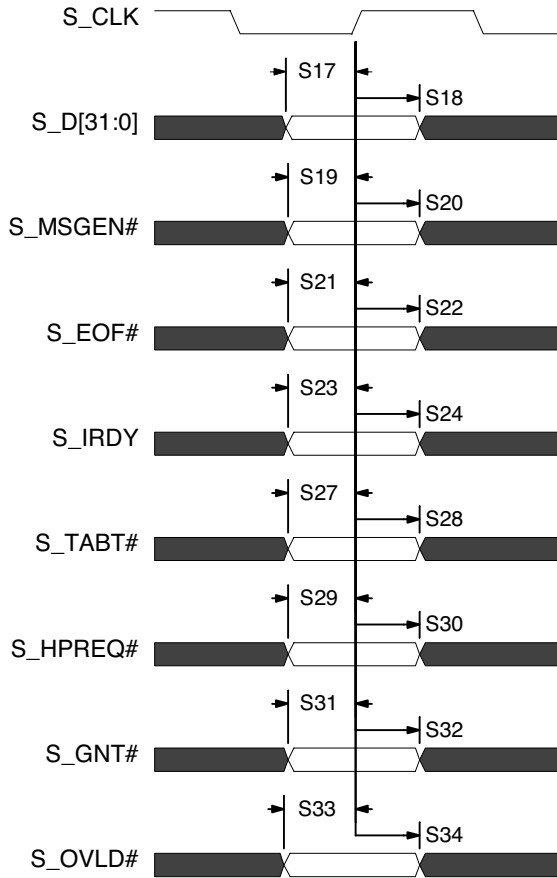

**XpressFlow Bus Interface –
Input setup and hold timing**

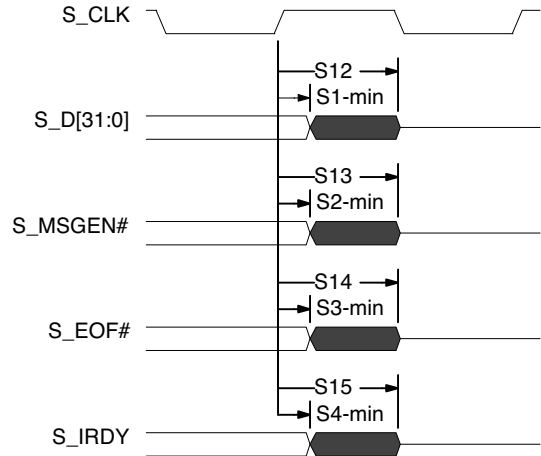

**XpressFlow Bus Interface –
Output float delay timing**

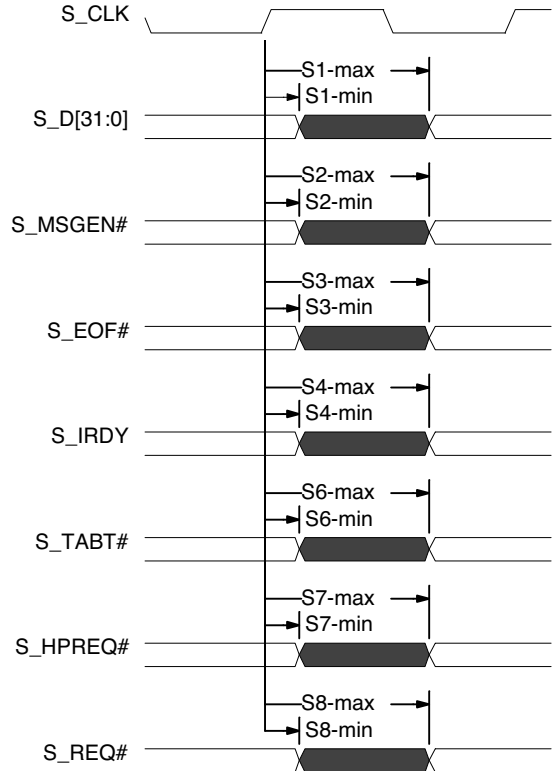

**XpressFlow Bus Interface –
Output valid delay timing**

Symbol	Parameter	-33		-40		-50		Note:
		Min (ns)	Max (ns)	Min (ns)	Max (ns)	Min (ns)	Max (ns)	
S1	S_D[31:0] output valid delay	6	20	5	18	4	15	C _L = 50pf
S2	S_MSGEN# output valid delay	6	20	5	18	4	15	C _L = 50pf
S3	S_EOF# output valid delay	6	20	5	18	4	15	C _L = 50pf
S4	S_IRDY output valid delay	6	20	5	18	4	15	C _L = 50pf
S6	S_TABT# output valid delay	6	20	5	18	4	15	C _L = 50pf
S7	S_HPREQ# output valid delay	6	20	5	18	4	15	C _L = 50pf
S8	S_REQ# output valid delay	6	20	5	18	4	15	C _L = 20pf
S12	S_D[31:0] output float delay		15		13		10	
S13	S_MSGEN# output float delay		15		13		10	
S14	S_EOF# output float delay		15		13		10	
S15	S_IRDY output float delay		15		13		10	
S17	S_D[31:0] input set-up time	5		4.5		4		
S18	S_D[31:0] input hold time	2		1.5		1.5		
S19	S_MSGEN# input set-up time	5		4.5		4		
S20	S_MSGEN# input hold time	2		1.5		1.5		
S21	S_EOF# input set-up time	5		4.5		4		
S22	S_EOF# input hold time	2		1.5		1.5		
S23	S_IRDY input set-up time	5		4.5		4		
S24	S_IRDY input hold time	2		1.5		1.5		
S27	S_TABT# input set-up time	5		4.5		4		
S28	S_TABT# input hold time	2		1.5		1.5		
S29	S_HPREQ# input set-up time	5		4.5		4		
S30	S_HPREQ# input hold time	2		1.5		1.5		
S31	S_GNT# input set-up time	5		4.5		4		
S32	S_GNT# input hold time	2		1.5		1.5		
S33	S_OVLD# input set-up time	5		4.5		4		
S34	S_OVLD# input hold time	2		1.5		1.5		

AC Characteristics – XpressFlow Bus Interface

6.2 CPU Bus Interface:

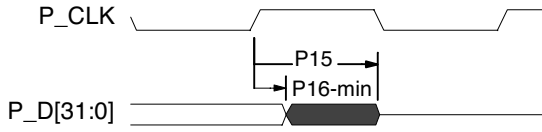

**CPU Bus Interface –
Output float delay timing**

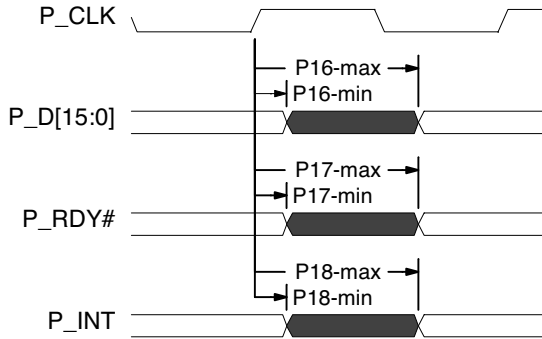

**CPU Bus Interface –
Output valid delay timing**

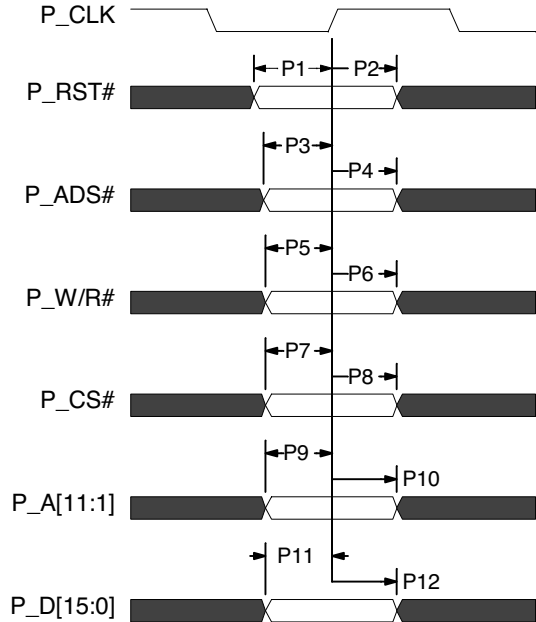

**CPU Bus Interface –
Input setup and hold timing**

Symbol	Parameter	-33		-40		-50		Note:
		Min (ns)	Max (ns)	Min (ns)	Max (ns)	Min (ns)	Max (ns)	
P1	P_RST# input setup time	5		4.5		4		
P2	P_RST# input hold time	2		1.5		1.5		
P3	P_ADS# input set-up time	5		4.5		4		
P4	P_ADS# input hold time	2		1.5		1.5		
P5	P_W/R# input set-up time	5		4.5		4		
P6	P_W/R# input hold time	2		1.5		1.5		
P7	P_CS# input set-up time	5		4.5		4		
P8	P_CS# input hold time	2		1.5		1.5		
P9	P_A[11:1] input set-up time	5		4.5		4		
P10	P_A[11:1] input hold time	2		1.5		1.5		
P11	P_D[31:0]# input set-up time	5		4.5		4		
P12	P_D[31:0]# input hold time	2		1.5		1.5		
P15	P_D[31:0]# output float delay		15		13		10	
P16	P_D[31:0]# # output valid delay	6	20	5	18	4	15	C _L = 60pf
P17	P_RDY# output valid delay	6	20	5	18	4	15	C _L = 60pf
P18	P_INT# output valid delay	6	20	5	18	4	15	C _L = 20pf

AC Characteristics -- CPU Bus Interface

6.3 Local Memory Interface:

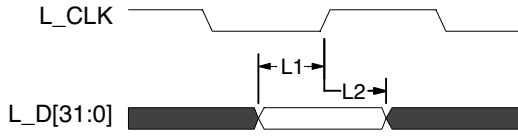

**Local Memory Interface –
Input setup and hold timing**

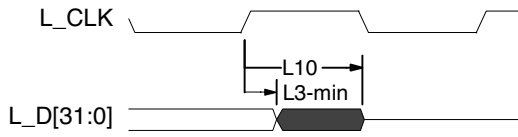

**Local Memory Interface –
Output float delay timing**

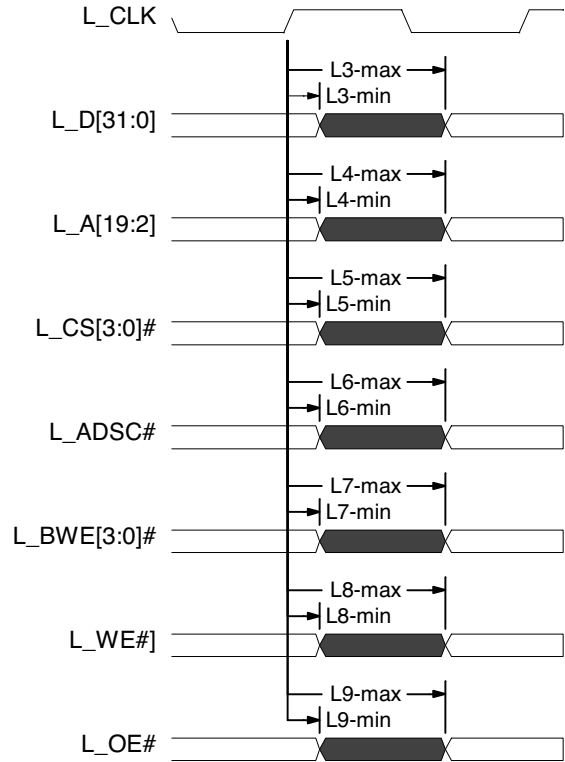

**Local Memory Interface –
Output valid delay timing**

Symbol	Parameter	-33		-40		-50		Note:
		Min (ns)	Max (ns)	Min (ns)	Max (ns)	Min (ns)	Max (ns)	
L1	L_D[31:0]# input set-up time	5		4.5		4		
L2	L_D[31:0]# input hold time	2		1.5		1.5		
L3	L_D[31:0]# output valid delay	6	20	5	18	4	15	C _L = 30pf
L4	L_A[19:2] output valid delay	6	20	5	18	4	15	C _L = 30pf
L5	L_CS[3:0]# output valid delay	6	20	5	18	4	15	
L6	L_ADSC# output valid delay	6	20	5	18	4	15	C _L = 30pf
L7	L_BWE[3:0]# output valid delay	6	20	5	18	4	15	C _L = 30pf
L8	L_WE# output valid delay	6	20	5	18	4	15	C _L = 10pf
L9	L_OE# output valid delay	6	20	5	18	4	15	C _L = 10pf
L10	L_D[31:0]# output float delay		15		13		10	

AC Characteristics – Local Memory Interface

7. PACKAGING INFORMATION

**352-PIN BGA
(35x35x2.33mm)**

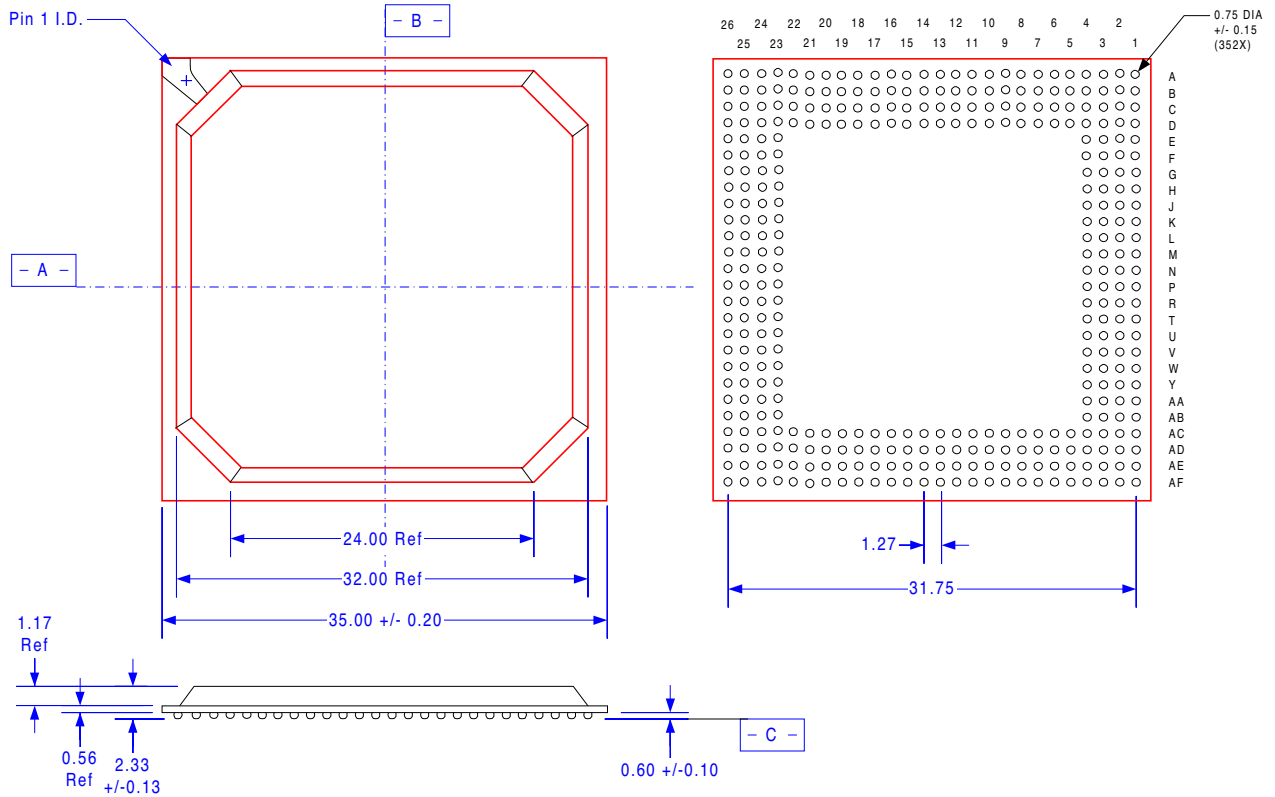

This Document contains advance information on a product under development. Zarlink Semiconductor Inc. reserves the right to make any changes without notice.



400 March Road
Ottawa, Ontario, Canada K2K 3H4
Tel. 613 592 0200, FAX: 613 592 1010
Web Site: www.zarlink.com

Rev. 4.0 December 1997

©1997 Zarlink Semiconductor Inc.

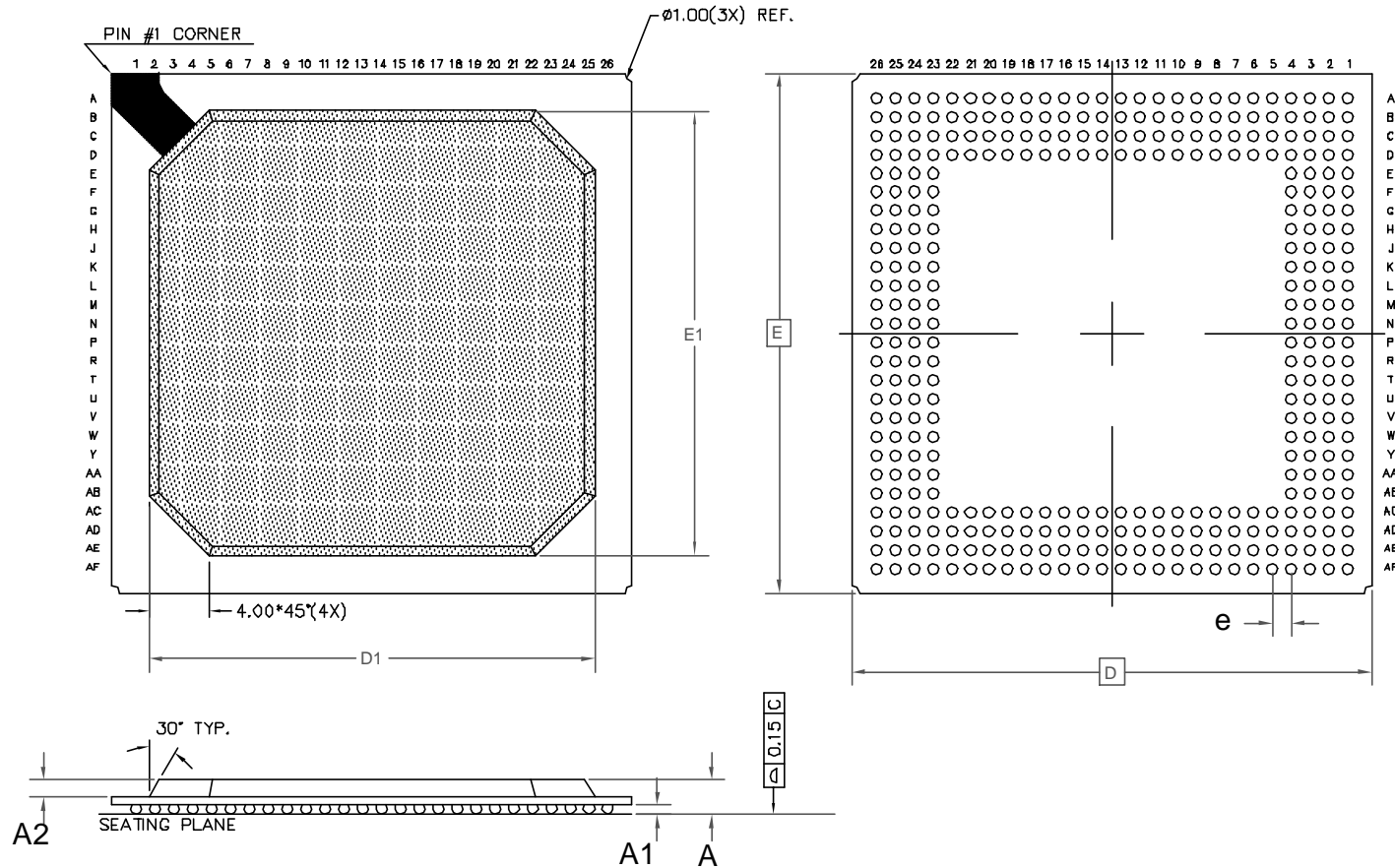

DIMENSION	MIN	MAX
A	2.20	2.46
A1	0.50	0.70
A2	1.17 REF	
D	34.80	35.20
D1	30.00 REF	
E	34.80	35.20
E1	30.00 REF	
b	0.60	0.90
e	1.27	
N	352	
Conforms to JEDEC MS - 034		

1. CONTROLLING DIMENSIONS ARE IN MM
2. DIMENSION "b" IS MEASURED AT THE MAXIMUM SOLDER BALL DIAMETER
3. SEATING PLANE IS DEFINED BY THE SPHERICAL CROWNS OF THE SOLDER BALLS.
4. N IS THE NUMBER OF SOLDER BALLS
5. NOT TO SCALE.
6. SUBSTRATE THICKNESS IS 0.56 MM

© Zarlink Semiconductor 2002 All rights reserved.					Package Code	GA
ISSUE	1				Previous package codes:	Package Outline for 352 Ball PBGA (35x35x2.33mm)
ACN	213933				BP / G	
DATE	20Jan03					
APPRD.					GPD00819	



**For more information about all Zarlink products
visit our Web Site at
www.zarlink.com**

Information relating to products and services furnished herein by Zarlink Semiconductor Inc. or its subsidiaries (collectively "Zarlink") is believed to be reliable. However, Zarlink assumes no liability for errors that may appear in this publication, or for liability otherwise arising from the application or use of any such information, product or service or for any infringement of patents or other intellectual property rights owned by third parties which may result from such application or use. Neither the supply of such information or purchase of product or service conveys any license, either express or implied, under patents or other intellectual property rights owned by Zarlink or licensed from third parties by Zarlink, whatsoever. Purchasers of products are also hereby notified that the use of product in certain ways or in combination with Zarlink, or non-Zarlink furnished goods or services may infringe patents or other intellectual property rights owned by Zarlink.

This publication is issued to provide information only and (unless agreed by Zarlink in writing) may not be used, applied or reproduced for any purpose nor form part of any order or contract nor to be regarded as a representation relating to the products or services concerned. The products, their specifications, services and other information appearing in this publication are subject to change by Zarlink without notice. No warranty or guarantee express or implied is made regarding the capability, performance or suitability of any product or service. Information concerning possible methods of use is provided as a guide only and does not constitute any guarantee that such methods of use will be satisfactory in a specific piece of equipment. It is the user's responsibility to fully determine the performance and suitability of any equipment using such information and to ensure that any publication or data used is up to date and has not been superseded. Manufacturing does not necessarily include testing of all functions or parameters. These products are not suitable for use in any medical products whose failure to perform may result in significant injury or death to the user. All products and materials are sold and services provided subject to Zarlink's conditions of sale which are available on request.

Purchase of Zarlink's I²C components conveys a licence under the Philips I²C Patent rights to use these components in and I²C System, provided that the system conforms to the I²C Standard Specification as defined by Philips.

Zarlink, ZL and the Zarlink Semiconductor logo are trademarks of Zarlink Semiconductor Inc.

Copyright Zarlink Semiconductor Inc. All Rights Reserved.

TECHNICAL DOCUMENTATION - NOT FOR RESALE
