

THE INFORMATION CONTAINED HEREIN IS CONSIDERED "PROPRIETARY" TO BEL FUSE INC. AND SHALL NOT BE COPIED, REPRODUCED OR DISCLOSED WITHOUT THE WRITTEN APPROVAL OF BEL FUSE INC.

PRELIMINARY



ELECTRICAL SPECIFICATIONS @25°C

SCHEMATIC

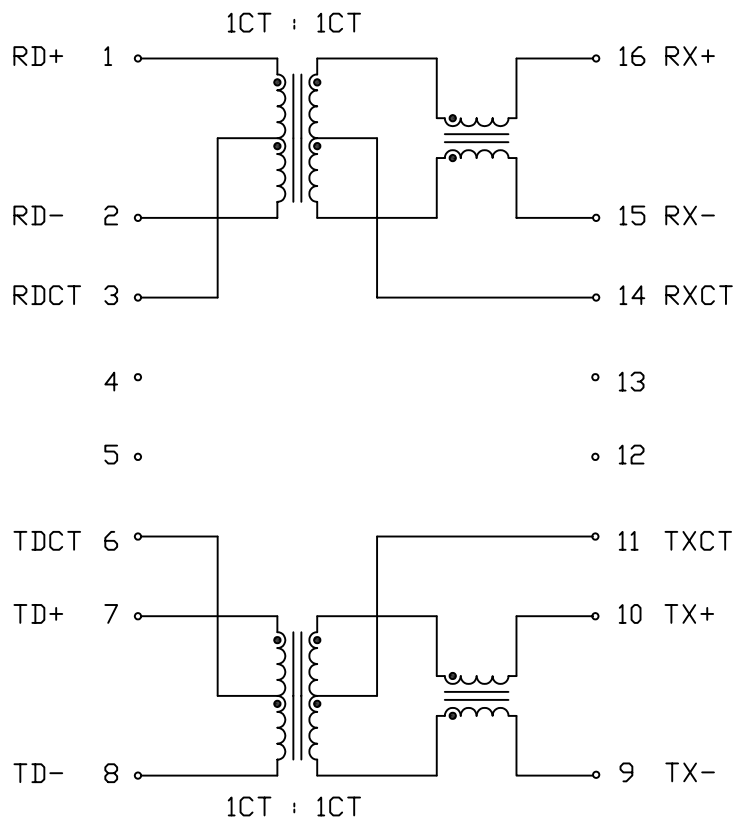

<p>URNS RATIO</p> <p>TX (7-8) : (10-9)</p> <p>RX (1-2) : (16-15)</p>	<p>1CT : 1CT ±2%</p> <p>1CT : 1CT ±2%</p>
<p>HASE</p>	<p>1 TO 16 AND 7 TO 10</p> <p>PER DOT CONVENTION</p>
<p>CL</p> <p>(1-2) ; (7-8)</p>	<p>350uH MIN. AT 100kHz, 100mV</p> <p>WITH 8mA DC BIAS, FROM 0 -70°C</p>
<p>INSERTION LOSS</p>	<p>1.2 dB MAX. AT 1 TO 125MHz</p>
<p>RETURN LOSS</p> <p>1-30 MHz</p> <p>40-50 MHz</p> <p>60 MHz</p> <p>80 MHz</p> <p>100 MHz</p>	<p>18 dB MIN.</p> <p>16 dB MIN.</p> <p>14 dB MIN.</p> <p>12 dB MIN.</p> <p>10 dB MIN.</p>
<p>CROSSTALK</p> <p>5-10 MHz</p> <p>100 MHz</p>	<p>40 dB MIN.</p> <p>30 dB MIN.</p>
<p>COMMON TO COMMON REJECTION</p>	<p>30 dB MIN. AT 100kHz TO 155MHz</p>
<p>HIPOT</p>	<p>PER HAND-WORK-03</p>

ORIGINATED BY	DATE	TITLE	PART NO. / DRAWING NO.	STANDARD DIM.	[ ] METRIC DIM. AS REFERENCE	<p>COMPONENTS OR A CONNECTED PLANET</p>	
HQ	07-19-06		X5585999BD-F	TOL. IN INCH	UNIT : INCH [mm]		REV. : PA
DRAWN BY	DATE		FILE NAME	.X	SCALE : N/A		SIZE : A4
DQ Chen	07-19-06	1000BT MAGNETICS MODULE S558-5999-BD-F	X5585999BDFPA.DWG	.XX ±0.01		PAGE : 2	
				.XXX ±0.005			

THE INFORMATION CONTAINED HEREIN IS CONSIDERED "PROPRIETARY" TO BEL FUSE INC. AND SHALL NOT BE COPIED, REPRODUCED OR DISCLOSED WITHOUT THE WRITTEN APPROVAL OF BEL FUSE INC.

PRELIMINARY

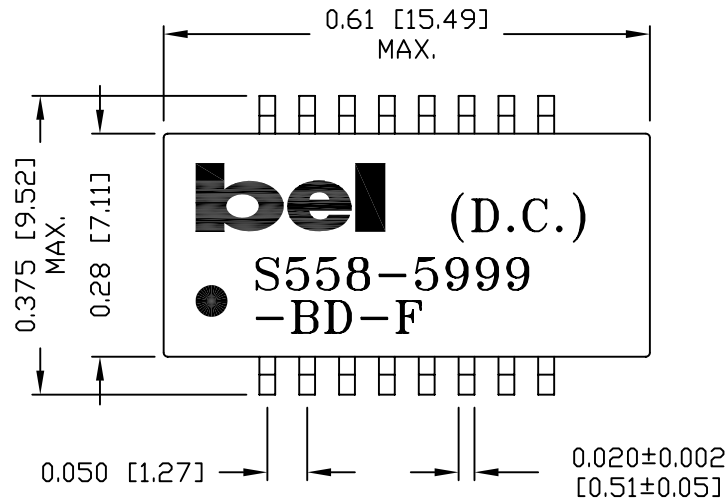

SUGGESTED PCB PAD LAYOUT

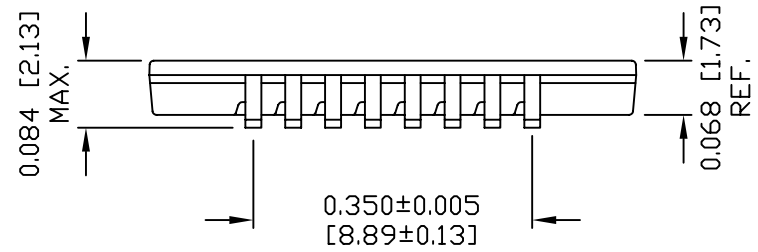
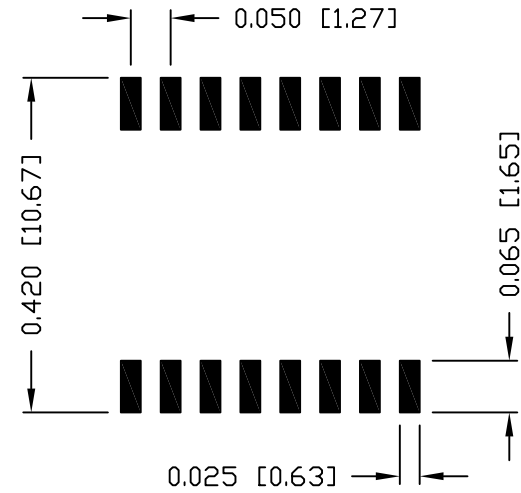

BETWEEN COMPONENTS AND INTERNAL LEADS TO SEATING PLANE WITH 0.002" MIN CLEARANCE

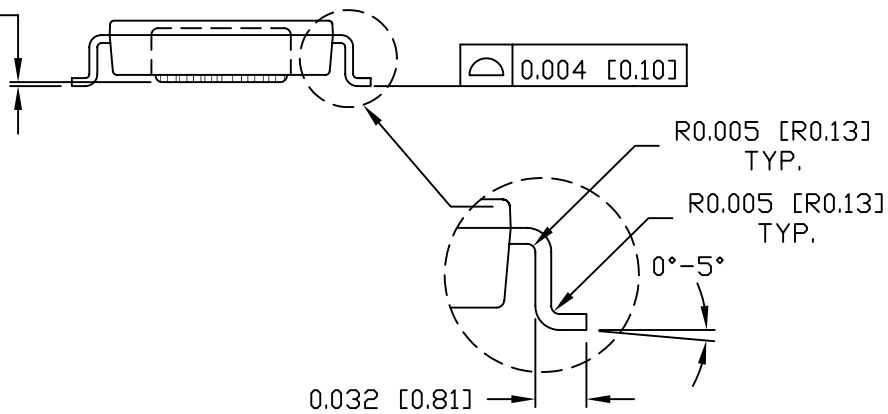

NOTES:

- STANDARD MARKING REFER TO DOC. HAND-WORK-04.
- PACKAGE CODE: "QZS001".

ORIGINATED BY	DATE	TITLE	PART NO. / DRAWING NO.	STANDARD DIM. TOL. IN INCH	[ ] METRIC DIM. AS REFERENCE	<p>COMPONENTS OR A CONNECTED PLANET</p>
HQ	07-19-06	MECHANICAL OUTLINE S558-5999-BD-F	X5585999BD-F	.X	UNIT : INCH [mm]	
DRAWN BY	DATE		FILE NAME	.XX ±0.01	SCALE : N/A	
DQ Chen	07-19-06	X5585999BDFPA.DWG	.XXX ±0.005	SCALE : N/A	SIZE : A4	
					PAGE : 3	