



# PA34

## PRELIMINARY

### FEATURES

- **LOW COST**
- **WIDE COMMON MODE RANGE** — Includes negative supply
- **WIDE SUPPLY VOLTAGE RANGE**  
Single supply: 5V to 40V  
Split supplies:  $\pm 2.5V$  to  $\pm 20V$
- **HIGH EFFICIENCY** —  $|V_s - 2.2V|$  at 2.5A typ
- **HIGH OUTPUT CURRENT** — 2.5A min
- **INTERNAL CURRENT LIMIT**
- **LOW DISTORTION**

### APPLICATIONS

- **HALF & FULL BRIDGE MOTOR DRIVERS**
- **AUDIO POWER AMPLIFIER**  
STEREO — 18W RMS per channel  
BRIDGE — 36W RMS per package
- **IDEAL FOR SINGLE SUPPLY SYSTEMS**  
5V — Peripherals  
12V — Automotive  
28V — Avionic

### DESCRIPTION

The PA34 consist of a monolithic power op amp in a 7-pin T0220 package.

The wide common mode input range includes the negative rail, facilitating single supply applications. It is possible to have a "ground based" input driving a single supply amplifier with ground acting as the "second" or "bottom" supply of the amplifier.

The output stage is also well protected. They possess internal current limit circuits. While the device is well protected, the Safe Operating Area (SOA) curve must be observed. Proper heatsinking is required for maximum reliability.

The tab of the 7 pin plastic package is tied to  $-V_s$ .

Graphic for PA34  
Here

### EXTERNAL CONNECTIONS

#### PA34

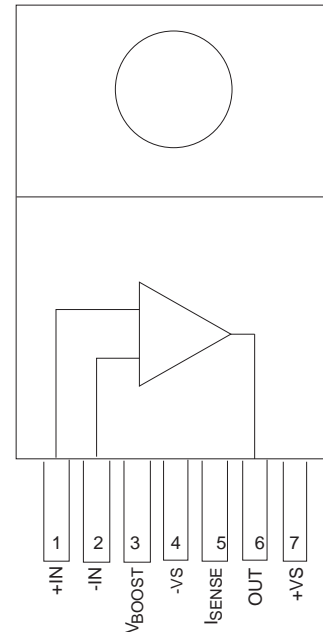

### ABSOLUTE MAXIMUM RATINGS

SUPPLY VOLTAGE, total	5V to 40V
OUTPUT CURRENT	SOA
POWER DISSIPATION, internal (per amplifier)	25W
INPUT VOLTAGE, differential	$\pm V_S$
INPUT VOLTAGE, common mode	$+V_S, -V_S-5V$
JUNCTION TEMPERATURE, max <sup>1</sup>	150°C
TEMPERATURE, pin solder—10 sec max	300°C
TEMPERATURE RANGE, storage	-65°C to 150°C
OPERATING TEMPERATURE RANGE, case	-55°C to 125°C

### SPECIFICATIONS

PARAMETER	TEST CONDITIONS <sup>2</sup>	PA34			UNITS
		MIN	TYP	MAX	
<b>INPUT</b>					
OFFSET VOLTAGE, initial			1.5	10	mV
OFFSET VOLTAGE, vs. temperature	Full temperature range		15		$\mu V/^{\circ}C$
BIAS CURRENT, initial		35	1000	nA	
COMMON MODE RANGE	Full temperature range	$-V_S-3$		$+V_S-2$	dB
COMMON MODE REJECTION, DC	Full temperature range	60	85		dB
POWER SUPPLY REJECTION	Full temperature range	60	80		dB
<b>GAIN</b>					
OPEN LOOP GAIN	Full temperature range	80	100		dB
GAIN BANDWIDTH PRODUCT	$A_V = 40dB$		600		kHz
PHASE MARGIN	Full temperature range		65		°
POWER BANDWIDTH	$V_{O(P-P)} = 28V$		13.6		kHz
<b>OUTPUT</b>					
CURRENT, peak		2.5			A
CURRENT, limit			3.0		A
SLEW RATE		.5	1.2		V/ $\mu s$
CAPACITIVE LOAD DRIVE	$A_V = 1$		.22		$\mu F$
VOLTAGE SWING	Full temp. range, $I_O = 100mA$	$ V_S  - 1.0$	$ V_S  - 0.8$		V
VOLTAGE SWING	Full temp. range, $I_O = 1A$	$ V_S  - 1.8$	$ V_S  - 1.4$		V
VOLTAGE SWING	$I_O = 2.5A$	$ V_S  - 3.0$	$ V_S  - 2.8$		V
VOLTAGE SWING	$I_O = 3.0A$				V
<b>POWER SUPPLY</b>					
VOLTAGE, $V_{SS}$ <sup>3</sup>		54	30	40	V
CURRENT, quiescent, total			45	90	mA
<b>THERMAL</b>					
RESISTANCE, DC junction to case			5.0		$^{\circ}C/W$
RESISTENCE, AC junction to case			3.7		$^{\circ}C/W$
RESISTANCE, junction to air			30		$^{\circ}C/W$
TEMPERATURE RANGE, case	Meets full range specifications	-25		85	$^{\circ}C$

#### NOTES:

1. Long term operation at the maximum junction temperature will result in reduced product life. Derate internal power dissipation to achieve high MTTF.
2. Unless otherwise noted, the following conditions apply:  $\pm V_S = \pm 15V$ ,  $T_C = 25^{\circ}C$ .
3.  $+V_S$  and  $-V_S$  denote the positive and negative supply rail respectively.  $V_{SS}$  denotes the total rail-to-rail supply voltage.
4. Current limit may not function properly below  $V_{SS} = 6V$ , however SOA violations are unlikely in this area.

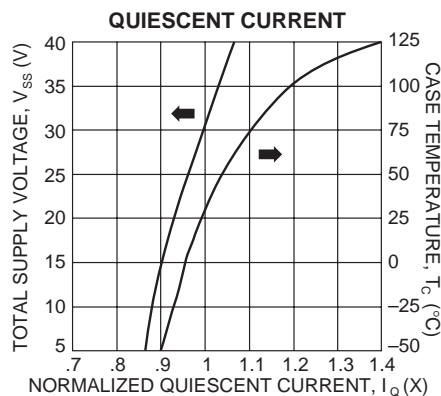
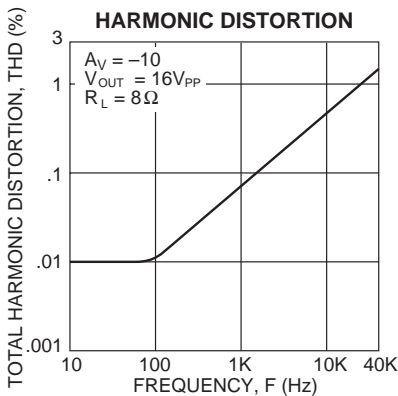
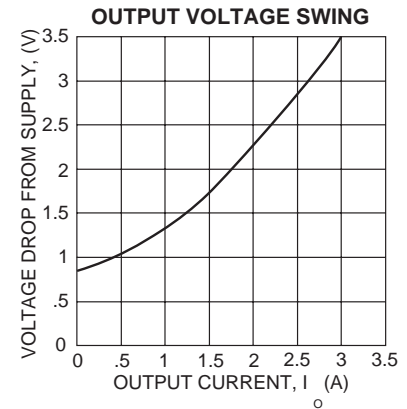
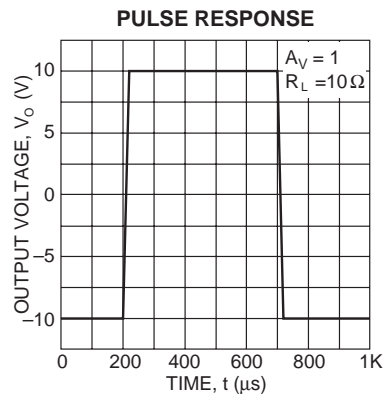
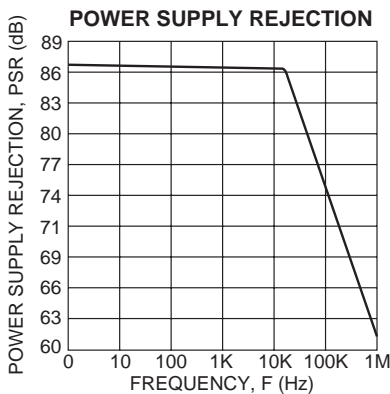
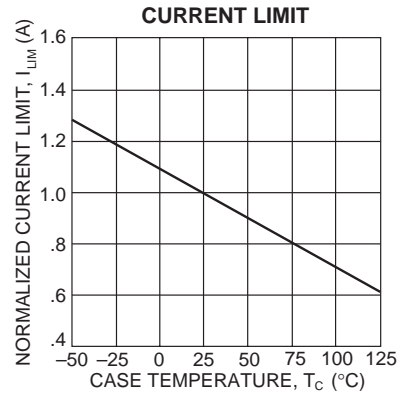
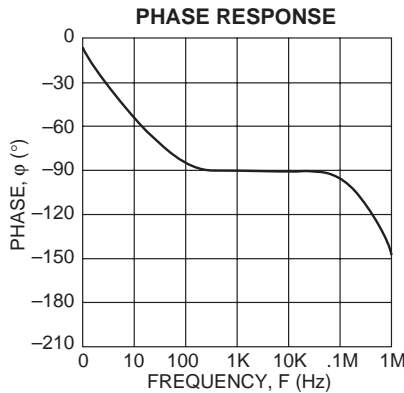
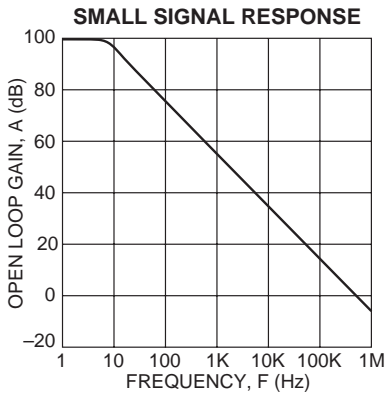
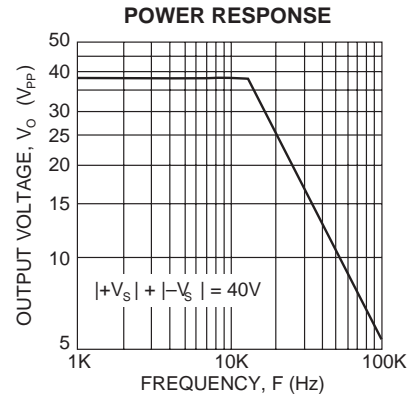
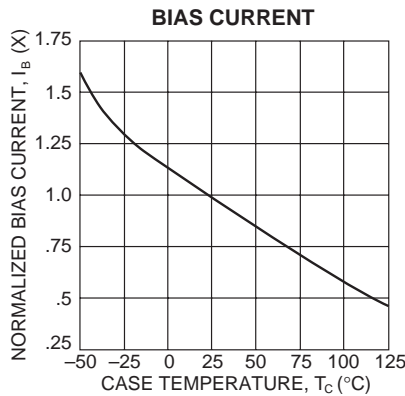
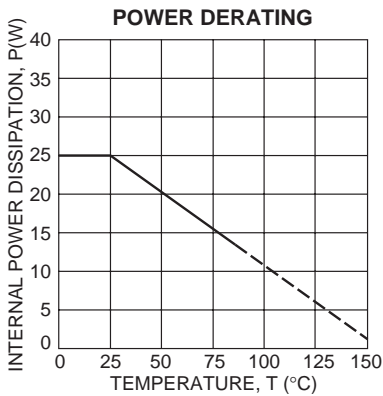

### GENERAL

Please read Application Note 1 "General Operating Considerations" which covers stability, supplies, heat sinking, mounting, current limit, SOA interpretation, and specification interpretation. Visit [www.apexmicrotech.com](http://www.apexmicrotech.com) for design tools that help automate tasks such as calculations for stability, internal power dissipation, current limit and heat sink selection. The "Application Notes" and "Technical Seminar" sections contain a wealth of information on specific types of applications. Package outlines, heat sinks, mounting hardware and other accessories are located in the "Packages and Accessories" section. Evaluation Kits are available for most Apex product models, consult the "Evaluation Kit" section for details. For the most current version of all Apex product data sheets, visit [www.apexmicrotech.com](http://www.apexmicrotech.com).

### CURRENT LIMIT

Current limit is internal to the amplifier, the typical value is shown in the current limit specification.

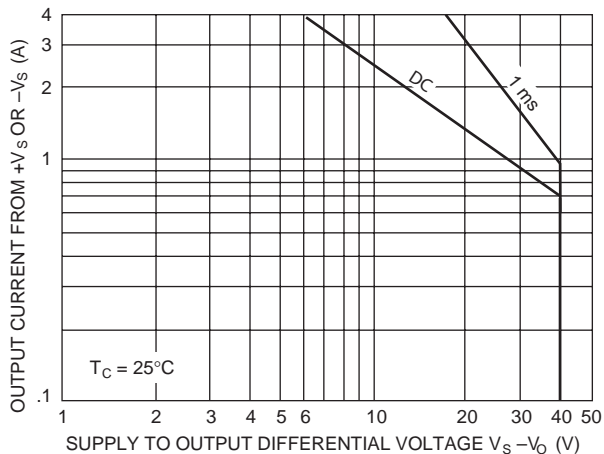

### SAFE OPERATING AREA (SOA)

The SOA curves combine the effect of all limits for this power op amp. For a given application, the direction and magnitude of the output current should be calculated or measured and checked against the SOA curves. This is simple for resistive loads but more complex for reactive and EMF generating loads. The following guidelines may save extensive analytical efforts.

Under transient conditions, capacitive and dynamic\* inductive loads up to the following maximum are safe:

$\pm V_S$	CAPACITIVE LOAD	INDUCTIVE LOAD
20V	200 $\mu$ F	7.5mH
15V	500 $\mu$ F	25mH
10V	5mF	35mH
5V	50mF	150mH

\* If the inductive load is driven near steady state conditions,

allowing the output voltage to drop more than 6V below the supply rail while the amplifier is current limiting, the inductor should be capacitively coupled or the supply voltage must be lowered to meet SOA criteria.

NOTE: For protection against sustained, high energy flyback, external fast-recovery diodes should be used.

### MONOLITHIC AMPLIFIER STABILITY CONSIDERATIONS

All monolithic power op amps use output stage topologies that present special stability problems. This is primarily due to non-complementary (both devices are NPN) output stages with a mismatch in gain and phase response for different polarities of output current. It is difficult for the op amp manufacturer to optimize compensation for all operating conditions.

The recommended R-C network of 1 ohm in series with 0.1 $\mu$ F from output to AC common (ground or a supply rail, with adequate bypass capacitors) will prevent local output stage oscillations.

The amplifiers are internally compensated for unity gain stability, no additional compensation is required.

### THERMAL CONSIDERATIONS

The PA34 may require a thermal washer which is electrically insulating since the tab is tied to  $-V_S$ . This can result in thermal impedances for  $R_{\theta CS}$  of up to 1°C/W or greater.

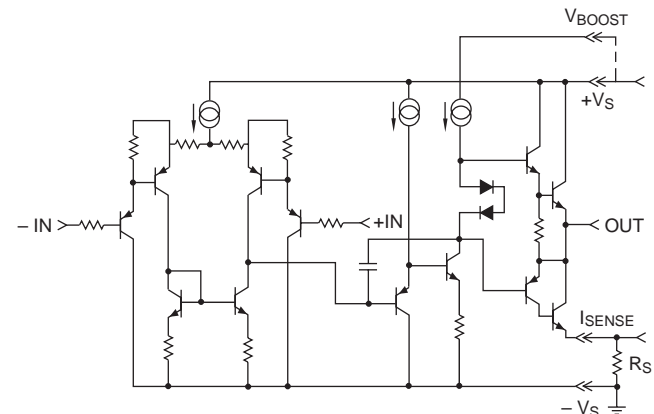

FIGURE 2. EQUIVALENT SCHEMATIC

### ADDITIONAL PA34 PIN FUNCTIONS

#### VBOOST

The  $V_{BOOST}$  pin is the positive terminal for the load of the second stage of the amplifier. When that terminal is connected to a voltage greater than  $+V_S$  it will provide more drive to the upper output transistor, which is a darlington connected emitter follower. This will better saturate the output transistor.

When  $V_{BOOST}$  is about 5 Volts greater than  $+V_S$  the positive output can swing 0.5 Volts closer to the rail. This is as much improvement as is possible.

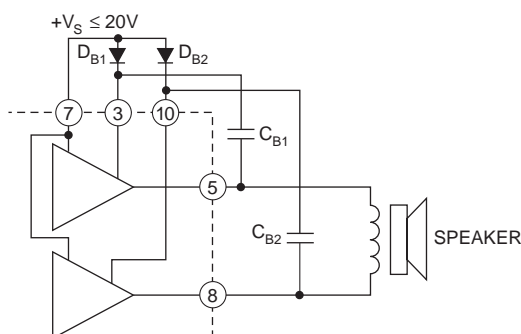

FIGURE 3. SIMPLE BOOTSTRAPPING IMPROVES POSITIVE OUTPUT SWING. CONNECT PINS 3 AND 10 TO  $V_S$  IF NOT USED. TYPICAL CURRENTS ARE 12mA EACH.

$V_{BOOST}$  pin requires approximately 10–12mA of current. Dynamically it represents 1K  $\Omega$  impedance. The maximum voltage that can be applied to  $V_{BOOST}$  is 40 volts with respect to  $-V_S$ . There is no limit to the difference between  $+V_S$  and  $V_{BOOST}$ .

Figure 3 shows a bootstrap which dynamically couples the output waveform onto the  $V_{BOOST}$  pin. This causes  $V_{BOOST}$  to swing positive from its initial value, which is equal to  $+V_S - 0.7V$  (one diode drop), an amount equal to the output. In other words, if  $V_{BOOST}$  was initially 19.3, and the output swings positive 18 Volts, the voltage on the  $V_{BOOST}$  pin will swing to  $19.3 - 0.7 + 18$  or 36.6. The capacitor needs to be sized based on a 1K  $\Omega$  impedance and the lowest frequency required by the circuit. For example, 20Hz will require  $> 8\mu F$ .

### I<sub>SENSE</sub>

The  $I_{SENSE}$  pin is in series with the negative half of the output stage only. Current will flow through this pin only when negative current is being outputted. The current that flows in this pin is the same current that flows in the output (if  $-1A$  flows in the output, the  $I_{SENSE}$  pin will have 1A of current flow, if  $+1A$  flows in the output the  $I_{SENSE}$  pin will have 0 current flow).

The resistor choice is arbitrary and is selected to provide whatever voltage drop the engineer desires, up to a maximum of 1.0 volt. However, any voltage dropped across the resistor will subtract from the swing to rail. For instance, assume a  $\pm 12$  volt power supply and a load that requires  $\pm 1A$ . With no current sense resistor the output could swing  $\pm 10.2$  volts. If a 1  $\Omega$  resistor is used for current sense (which will drop 1 Volt at 1 Amp) then the output could swing  $\pm 10.2, -9.2$  Volts.

Figure 4 shows the PA34  $I_{SENSE}$  feature being used to obtain a Transconductance function. In this example, amplifier "A" is the master and amplifier "B" is the slave. Feedback from sensing resistors  $R_S$  is applied to the summing network and scaled to the inverting input of amplifier "A" where it is compared to the input voltage. The current sensing feedback imparts a Transconductance feature to the amplifiers transfer function. In other words, the voltage developed across the sensing resistors is directly proportional to the output current.

Using this voltage as a feedback source allows expressing the gain of the circuit in amperes vs input voltage. The transfer function is approximately:

$$I_L = (V_{IN} - V_{REF}) * R_{IN} / R_{FB} / R_S$$

In the illustration, resistors  $R_{IN}$ ,  $R_{FB}$  and  $R_S$  determine gain.

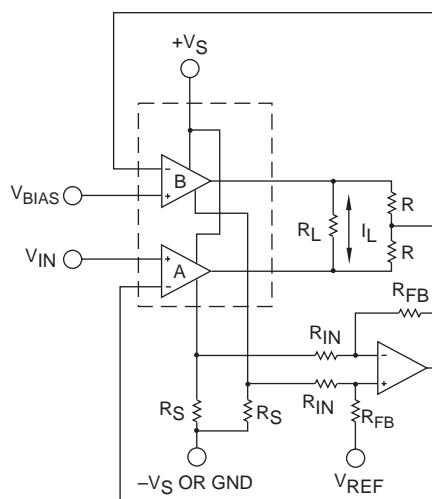

FIGURE 4. I<sub>SENSE</sub> TRANSCONDUCTANCE BRIDGING AMPLIFIER

$V_{BIAS}$  should be set midway between  $+V_S$  and  $-V_S$ ,  $V_{ref}$  is usually ground in dual supply systems or used for level translation in single supply systems.

### MOUNTING PRECAUTIONS

1. Always use a heat sink. Even unloaded, the PA34 can dissipate up to 3.6 watts. A thermal washer or thermal grease should always be used.
2. Avoid bending the leads. Such action can lead to internal damage.
3. Always fasten the tab to the heat sink before the leads are soldered to fixed terminals.
4. Strain relief must be provided if there is any probability of axial stress to the leads.