

Product Specification

SPECIFICATION FOR APPROVAL

- () Preliminary Specification
- (●) Final Specification



Gleichmann & Co. Electronics GmbH
Product Marketing Displays & Systems
Industriestr. 16, D- 76297 Stutensee
Tel :07249-910-0, Fax: 07249-910-559
<http://www.msc-ge.com>

Title	23.0" WUXGA TFT LCD
-------	---------------------

BUYER	APPLE
MODEL	

SUPPLIER	LG.Philips LCD Co., Ltd.
*MODEL	LM230W01
Suffix	A2P3

SIGNATURE	DATE
/	_____
/	_____
/	_____

Please return 1 copy for your confirmation with your signature and comments.

SIGNATURE	DATE
S.W.Lee / G.Manager 	6. Feb. 2003
REVIEWED BY	
J.T.Eu / Manager 	Feb. 06 '03
PREPARED BY	
B.C Kim / Engineer 	FEB. 06. 2003

MNT/TV Products Engineering Dept.
LG. Philips LCD Co., Ltd

Product Specification

Contents

No	ITEM	Page
	COVER	1
	CONTENTS	2
	RECORD OF REVISIONS	3
1	GENERAL DESCRIPTION	4
2	ABSOLUTE MAXIMUM RATINGS	5
3	ELECTRICAL SPECIFICATIONS	6
3-1	ELECTRICAL CHARACTREISTICS	6
3-2	INTERFACE CONNECTIONS	8
3-3	SIGNAL TIMING SPECIFICATIONS	11
3-4	SIGNAL TIMING WAVEFORMS	12
3-5	COLOR INPUT DATA REFERNECE	13
3-6	POWER SEQUENCE	14
4	OPTICAL SFECIFICATIONS	15
5	MECHANICAL CHARACTERISTICS	19
6	RELIABLITY	22
7	INTERNATIONAL STANDARDS	23
7-1	SAFETY	23
7-2	EMC	23
8	PACKING	24
8-1	DESIGNATION OF LOT MARK	24
8-2	PACKING FORM	24
9	PRECAUTIONS	25
	APPENDIX	27

Product Specification

1. General Description

The LM230W01 LCD is a Color Active Matrix Liquid Crystal Display with an integral Cold Cathode Fluorescent Lamp(CCFL) back light system. The matrix employs a-Si Thin Film Transistor as the active element. It is a transmissive type display operating in the normally black mode. This TFT-LCD has a 23.0 inch diagonally measured active display area with WUXGA resolution(1920 vertical by 1200 horizontal pixel array). Each pixel is divided into Red, Green and Blue sub-pixels or dots which are arranged in vertical stripes. Gray scale or the luminance of the sub-pixel color is determined with a 8-bit gray scale signal for each dot, thus, presenting a palette of more than 16,777,216 colors.

The LM230W01 has been designed to apply the TMDSTTM(Transition Minimized differential Signaling) as the interface method to enable a simple and low-cost implementation in both the host and monitor.

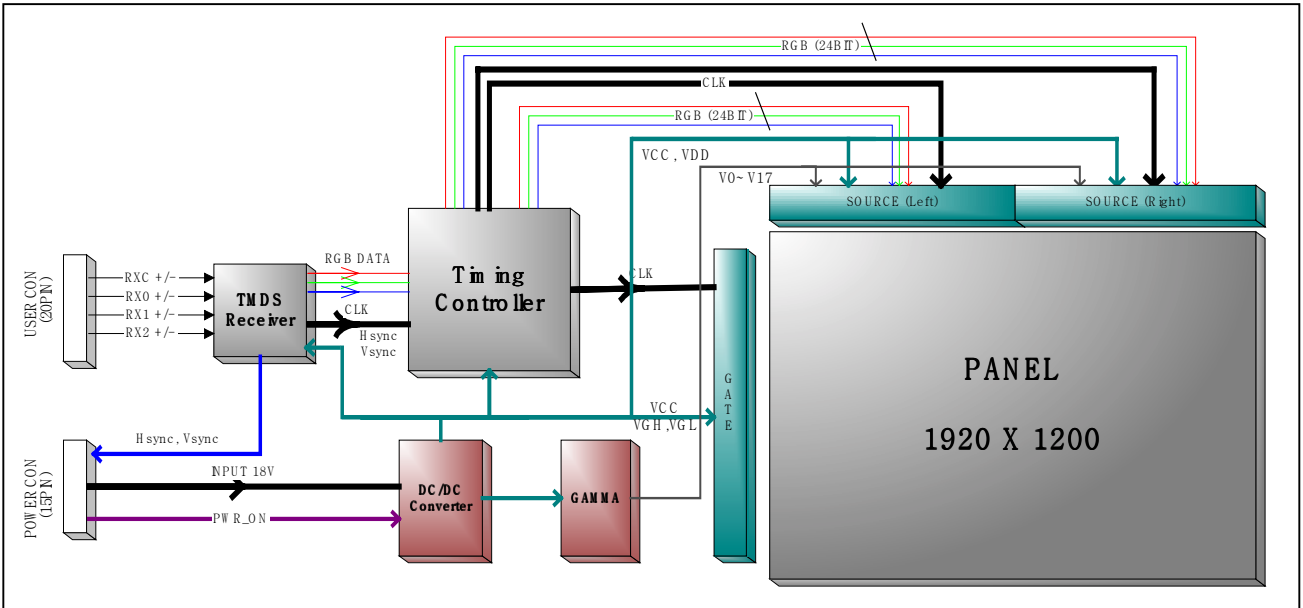

General Features

Active Screen Size	23.0 inches(58.4cm) diagonal
Outline Dimension	550.0(H) x 360.5(V) x 25.0(D) mm(Typ.)
Active Area	495.36[mm] × 309.6[mm]
Pixel Pitch	0.258 mm x 0.258mm
Pixel Format	1920 horiz. By 1200 vert. Pixels RGB stripes arrangement
Color Depth	8-bit, 16,777,216 colors
Luminance, White	200 cd/m ² (Typ.)
Power Consumption	Total 47 Watt(Typ.)
Weight	4,500 g (typ.)
Display Operating Mode	Transmissive mode, normally black
Surface Treatment	Hard coating(3H) Anti-glare treatment of the front polarizer,
Interface	TMDS (Hsync/DE)
LAMP	6 CCFL's(Cold Cathode Fluorescent Lamp)

Product Specification

2. Absolute Maximum Ratings

The following are maximum values which, if exceeded, may cause operation or damage to the unit.

Table 1. ABSOLUTE MAXIMUM RATINGS

Parameter	Symbol	Values		Units	Notes
		Min	Max		
Power Input Voltage	Vcc	-0.3	21	Vcc	at 25 ± 5° C
Operating Temperature	TOP	0	50	° C	1
Storage Temperature	HST	-20	60	° C	1
Operating Ambient Humidity	HOP	10	90	%RH	1
Storage Humidity	HST	10	90	%RH	1

Note : 1. Temperature and relative humidity range are shown in the figure below.
Wet bulb temperature should be 39° C Max, and no condensation of water.

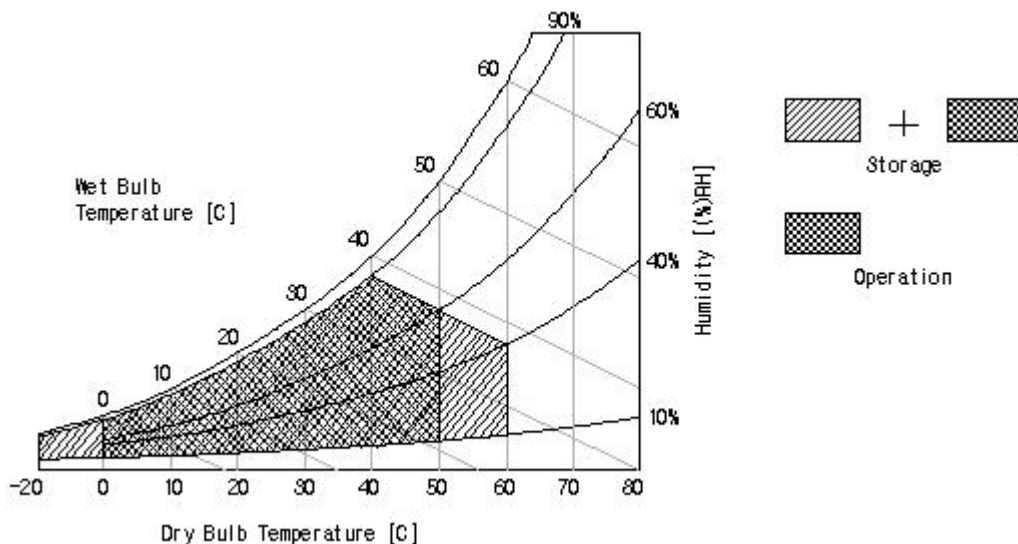

Product Specification
3. Electrical Specifications
3-1. Electrical Characteristics

The LM230W01 requires two power inputs. One input is employed to power the LCD electronics and to drive the voltages to drive the TFT array and liquid crystal. And the second input which powers the CCFL, is typically generated by an inverter. The inverter is an external unit to the LCD.

Table 2. ELECTRICAL CHARACTERISTICS

Parameter	Symbol	Values			Unit	Notes
		Min	Typ	Max		
MODULE :						
Power Supply Input Voltage	V _{CC}	17.0	18.0	19.0	V _{dc}	
Power Supply Input Current	I _{CC}	-	0.45	0.65	A	1
Power Consumption	P _C	-	8.1	11.7	Watt	1
Inrush Current	I _{Rush}	-	-	3	A	2
LAMP :						
Operating Voltage	V _{BL}	830(9mA)	875(7.5mA)	1090(2.5mA)	V _{RMS}	3
Operating Current	I _{BL}	2.5	7.5	9.0	mA	
Established Starting Voltage	V _S					4
at 25 ° C		-	-	1400	V _{RMS}	
at 0 ° C		-	-	1960	V _{RMS}	
Operating Frequency	F _{BL}	40	50	60	KHz	5
Power Consumption	P _{BL}	-	41.0	45.1	Watt	6
Discharge Stabilization Time	T _S	-	-	3	min	7
Life Time		30,000			Hrs	8

Notes : 1. The input current shall be measured at V_{CC} of 18.0V_{dc} at 25°C, refresh rate of 60Hz, and pixel clock frequency of 156MHz under mosaic pattern(8x6) (typ).

2. The measuring condition

The duration of rush current is about 20ms, and rising time of Power input is 1ms.

3. The variance of the voltage is ± 10%.

4. Operating voltage is measured at 25° C. The variance of the voltage is ± 10%.

5. The output voltage at the transformer in the inverter must be high considering to the loss of the ballast capacitor in the inverter. The voltage above V_S should be applied to the lamps for more than 1 second for start-up. Otherwise, the lamps may not be turned on.

6. Lamp frequency may produce interface with horizontal synchronous frequency and as a result this may cause beat on the display. Therefore lamp frequency shall be as away possible from the horizontal synchronous frequency and from its harmonics in order to prevent interference.

7. The lamp power consumption shown above does not include loss of external inverter at 25° C. The used lamp current is the lamp typical current.

Product Specification

8. Let's define the brightness of the lamp after being lighted for 5 minutes as 100%.
 T_S is the time required for the brightness of the center of the lamp to be not less than 95%.
The used lamp current is the lamp typical current.
9. The life time is defined as the time at which brightness of lamp is 50% compare to that of initial value at the typical lamp current on condition of continuous operating at $25 \pm 2^\circ\text{C}$.

Note. Do not attach a conducting tape to connecting wire.

If the lamp wire attach to a conducting tape, TFT-LCD Module has a low luminance and the inverter has abnormal action. Because leakage current is occurred between lamp wire and conducting tape.

The design of the inverter must have specifications for the lamp in LCD Assembly.

The performance of the Lamp in LCM, for example life time or brightness, is extremely influenced by the characteristics of the DC-AC inverter. So all the parameters of an inverter should be carefully designed so as not to produce too much leakage current from high-voltage output of the inverter.

When you design or order the inverter, please make sure unwanted lighting caused by the mismatch of the lamp and the inverter(no lighting, flicker, etc) never occurs. When you confirm it, the LCD – Assembly should be operated in the same condition as installed in you instrument.

Requirements for a system inverter design, which is intended to have a better display performance, a better power efficiency and a more reliable lamp.

It shall help increase the lamp lifetime and reduce its leakage current.

- a. The asymmetry rate of the inverter current and voltage waveform should be 10% below;
- b. The distortion rate of the current and voltage waveform should be within $\sqrt{2} \pm 10\%$;
- c. The ideal sine current and voltage waveform shall be symmetric in positive and negative polarities.

$$* \text{ Asymmetry rate} = | I_p - I_{-p} | / I_{\text{rms}} * 100\%$$

$$* \text{ Distortion rate} = I_p \text{ (or } I_{-p}) / I_{\text{rms}}$$

Product Specification

3-2. Interface Connections

This LCD employs three kinds of interface connections. A 20 pin connector is used for TMDS signals from the host computer. A 15-pin connector is used for LCD module power and LCM controls signal from external monitor control circuits. And six connectors, two pin connector, are used for the integral backlight system.

3-2-1. Signal Interface

The TMDS signal interface connector is FI-XL20S-HF by JAE.
The pin configuration for the 20 pin connector is shown in the table below.

Table 3 20PIN CONNECTOR (CNC6) PIN CONFIGURATION

Pin	Symbol	Description	Pin	Symbol	Description
1	GND	Ground	11	SHLD0	Shield for TMDS channel 0
2	GND	Ground	12	TX0+	TMDS positive differential output (Channel 0)
3	GND	Ground	13	TX0-	TMDS negative differential output (Channel 0)
4	GND	Ground	14	SHLDC	Shield for TMDS channel C
5	SHLD2	Shield for TMDS channel 2	15	TXC+	TMDS positive differential output (Channel C)
6	TX2+	TMDS positive differential output (Channel 2)	16	TXC-	TMDS negative differential output (Channel C)
7	TX2-	TMDS negative differential output (Channel 2)	17	GND	Ground
8	SHLD1	Shield for TMDS channel 1	18	GND	Ground
9	TX1+	TMDS positive differential output (Channel 1)	19	GND	Ground
10	TX1-	TMDS negative differential output (Channel 1)	20	GND	Ground
1. Interface chips 1.1 LCD : PTFP 403 PZP (TI)					
2. Connector					
2.1 LCD : FI-XL20S-HF					
2.2 Mating : FI-XL20H or compatible					
2.3 Connector pin arrangement					

Notes: 1. All shield pins and GND(ground) pin should be connected together and should also be connected to the LCD's metal frame.

Product Specification

3-2-2. Power Interface

A 15 pin connector (CNC7) for external monitor control circuits, is a model 53261 manufactured by Molex. The mating connector part number is 51021 or its equivalent. The pin configuration for this connector is shown in the table below.

Table 4 15 PIN CONNECTOR (CNC7) PIN CONFIGURATION

Pin	Symbol	Description	Notes
1	GND	Ground	
2	GND	Ground	
3	PWR_ON	Power ON control signal input 5V(H:90%,L:10%)	
4	GND	Ground	
5	Vcc	LCM power supply, +18V \pm 5%	
6	Vcc	LCM power supply, +18V \pm 5%	
7	Vcc	LCM power supply, +18V \pm 5%	
8	Vcc	LCM power supply, +18V \pm 5%	
9	GND	Ground	
10	DDC_CLK	DDC clock line out	
11	DDC_DAT	DDC data line out	
12	GND	Ground	
13	HS_OUT	Hsync Output	
14	VS_OUT	Vsync Output	
15	GND	Ground	

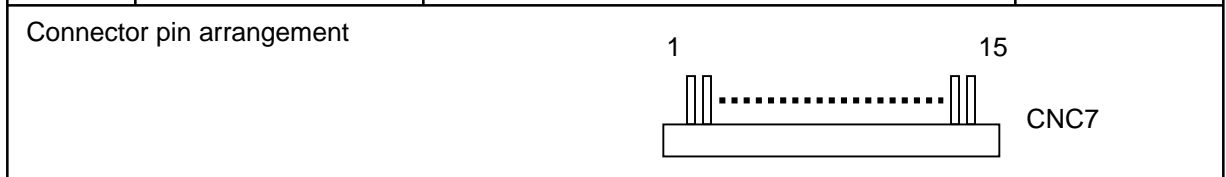

Notes: 1. All GND(ground) pins should be connected together and should also be connected to the LCD's metal frame.

Product Specification

3-2-3. Backlight Interface

The backlight interface connector is a model BHSR-02VS-1(CN2/CN3) and BHSR-05VS-1 (CN1/CN4) manufactured by JST. The mating connector part number are SM02B-BHSS-1-TB(2pin), SM04(9-E2)B-BHS-1-TB or equivalent. The pin configuration for the connector is shown in the table below.

Table 5 BACKLIGHT CONNECTOR PIN CONFIGURATION

No	Pin	Symbol	Description	Notes
CN1	1	HV	Power supply for lamp 1(High voltage side) - Pink	1
	2	HV	Power supply for lamp 2(High voltage side) - Blue	1
	3	NC	NC	
	4	LV	Power supply for lamp 1(Low voltage side) - White	
	5	LV	Power supply for lamp 2(Low voltage side) - White	
CN2	1	HV	Power supply for lamp 3(High voltage side) - Gray	1
	2	LV	Power supply for lamp 3(Low voltage side) - White	
CN3	1	HV	Power supply for lamp 4(High voltage side) - Gray	1
	2	LV	Power supply for lamp 4(Low voltage side) - White	
CN4	1	HV	Power supply for lamp 6(High voltage side) - Pink	1
	2	HV	Power supply for lamp 5(High voltage side) - Blue	1
	3	NC	NC	
	4	LV	Power supply for lamp 5(Low voltage side) - White	
	5	LV	Power supply for lamp 6(Low voltage side) - White	

Notes: 1. The high voltage power terminal is colored pink,blue,gray. Ground pin color is white.

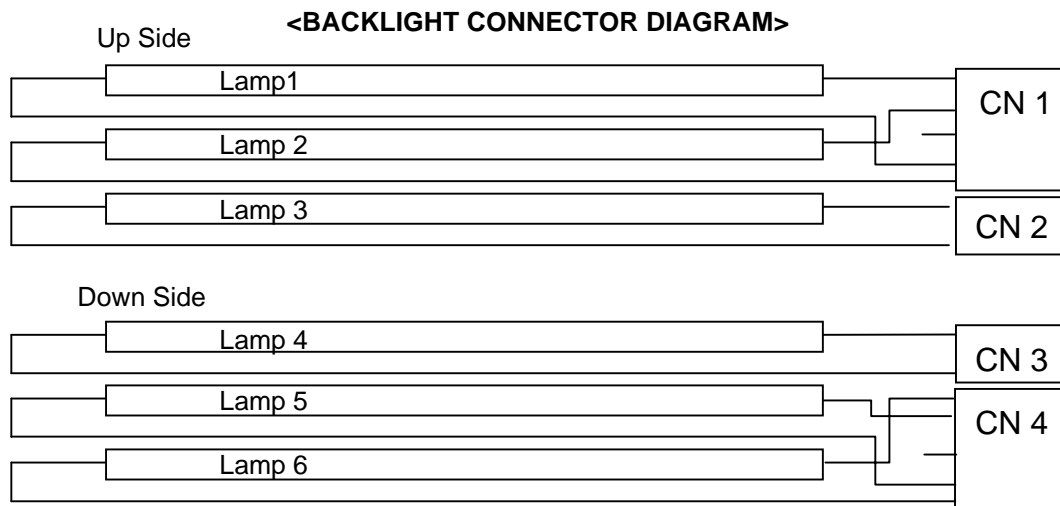

Product Specification
3-3. Signal Timing Specifications

This is signal timing required at the input of the TMDS transmitter. All of the interface signal timing should be satisfied with the following specifications for it's proper operation.

Table 6. Timing Table

ITEM		SYMBOL	Min	Typ	Max	Unit	Note
DCLK	Period	tCLK	6.49	6.41	6.33	Ns	
	Frequency	fCLK	154	156	158	MHz	
Hsync	Period	tHP	1984	2144	-	tCLK	1
	Width-Active	tWH	32	32	32		2
Vsync	Period	tVP	1206	1212	-	tHP	
	Frequency	fV	56	60	64	Hz	3
	Width-Active	tWV	2	3	-	tHP	4
Data Enable	Horizontal Valid	tHV	1920	1920	1920	tCLK	
	Horizontal Back Porch	tHBP	16	128	-		
	Horizontal Front Porch	tHFP	16	64	-		
	Horizontal Blank	-	64	224	-		tWH+ tHBP+ tHFP
	Vertical Valid	tVV	1200	1200	1200	tHP	
	Vertical Back Porch	tVBP	3	6	-		
	Vertical Front Porch	tVFP	1	3	-		
	Vertical Blank	-	6	12	-		tWV+ tVBP+ tVFP

- Notes: 1. Hsync period shall be a double number of 8
 2. Horizontal sync shall be active high.
 3. Vertical frequency should be keep the above specification when the resolution & mode are changed.
 4. Vertical sync shall be active high.

Product Specification

3-4. Signal Timing Waveforms

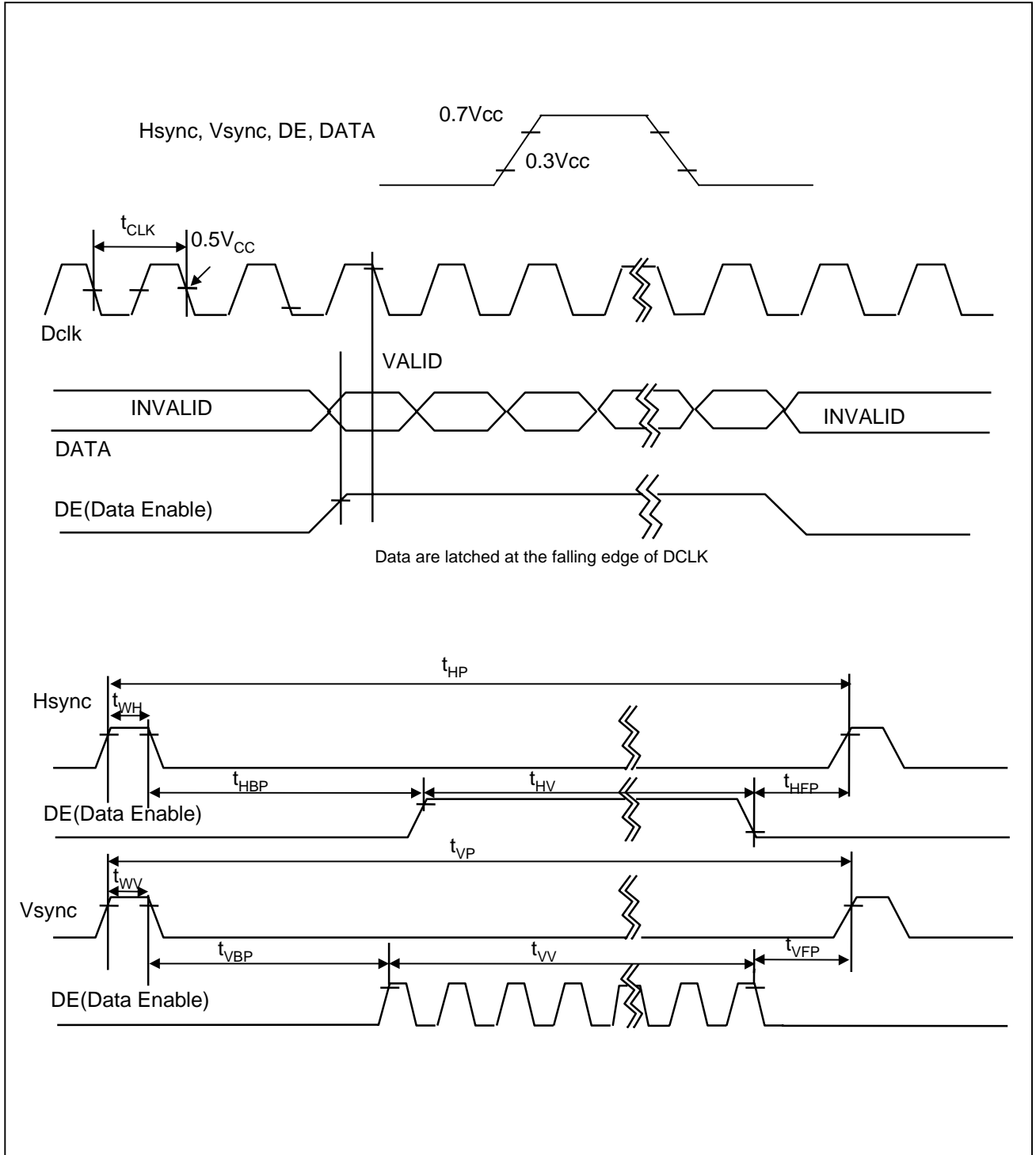

Product Specification

3-5. Color Input Data Reference

The brightness of each primary color(red,green and blue) is based on the 8-bit gray scale data input for the color ; the higher the binary input, the brighter the color. The table below provides a reference for color versus data input.

Table 7. COLOR DATA REFERENCE

Color		Input Color Data																							
		RED								GREEN								BLUE							
		MSB							LSB	MSB							LSB	MSB							LSB
R7	R6	R5	R4	R3	R2	R1	R0	G7	G6	G5	G4	G3	G2	G1	G0	B7	B6	B5	B4	B3	B2	B1	B0		
Basic Color	Black	0	0	0	0	0	0	0	0	0	0	0	0	0	0	0	0	0	0	0	0	0	0	0	0
	Red (255)	1	1	1	1	1	1	1	1	0	0	0	0	0	0	0	0	0	0	0	0	0	0	0	0
	Green (255)	0	0	0	0	0	0	0	0	1	1	1	1	1	1	1	1	0	0	0	0	0	0	0	0
	Blue (255)	0	0	0	0	0	0	0	0	0	0	0	0	0	0	0	0	1	1	1	1	1	1	1	1
	Cyan	0	0	0	0	0	0	0	0	1	1	1	1	1	1	1	1	1	1	1	1	1	1	1	1
	Magenta	1	1	1	1	1	1	1	1	0	0	0	0	0	0	0	0	1	1	1	1	1	1	1	1
	Yellow	1	1	1	1	1	1	1	1	1	1	1	1	1	1	1	1	0	0	0	0	0	0	0	0
	White	1	1	1	1	1	1	1	1	1	1	1	1	1	1	1	1	1	1	1	1	1	1	1	1
RED	RED (000)	0	0	0	0	0	0	0	0	0	0	0	0	0	0	0	0	0	0	0	0	0	0	0	0
	RED (001)	0	0	0	0	0	0	0	1	0	0	0	0	0	0	0	0	0	0	0	0	0	0	0	0
							
	RED (254)	1	1	1	1	1	1	1	0	0	0	0	0	0	0	0	0	0	0	0	0	0	0	0	0
	RED (255)	1	1	1	1	1	1	1	1	0	0	0	0	0	0	0	0	0	0	0	0	0	0	0	0
GREEN	GREEN (000)	0	0	0	0	0	0	0	0	0	0	0	0	0	0	0	0	0	0	0	0	0	0	0	0
	GREEN (001)	0	0	0	0	0	0	0	0	0	0	0	0	0	0	0	1	0	0	0	0	0	0	0	0
							
	GREEN (254)	0	0	0	0	0	0	0	0	1	1	1	1	1	1	1	0	0	0	0	0	0	0	0	0
	GREEN (255)	0	0	0	0	0	0	0	0	1	1	1	1	1	1	1	1	0	0	0	0	0	0	0	0
BLUE	BLUE (000)	0	0	0	0	0	0	0	0	0	0	0	0	0	0	0	0	0	0	0	0	0	0	0	0
	BLUE (001)	0	0	0	0	0	0	0	0	0	0	0	0	0	0	0	0	0	0	0	0	0	0	0	1
							
	BLUE (254)	0	0	0	0	0	0	0	0	0	0	0	0	0	0	0	0	1	1	1	1	1	1	1	0
	BLUE (255)	0	0	0	0	0	0	0	0	0	0	0	0	0	0	0	0	1	1	1	1	1	1	1	1

Product Specification

3-6. Power Sequence

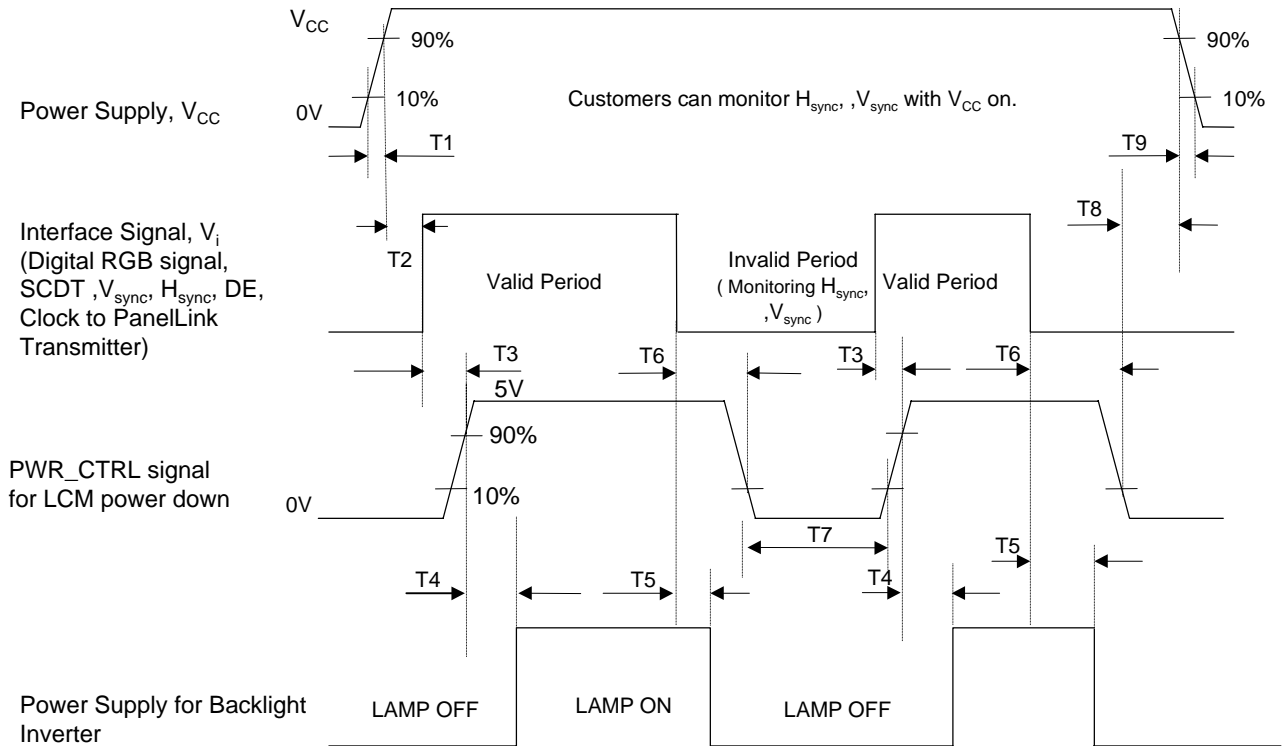

Parameter	Values			Units
	Min	Typ	Max	
T1	-	-	10	ms
T2	50	-	-	ms
T3	-	-	50	ms
T4	100	-	-	ms
T5	-	-	50	ms
T6	-	-	80	ms
T7	400	-	-	ms
T8	50	-	-	
T9	-	-	10	

- Notes :
1. Please avoid floating state of interface signal at invalid period.
 2. When the interface signal is invalid, be sure to pull down the power supply for LCD V_{CC} to 0V.
 3. Lamp power must be turn on after power supply for LCD and interface signal are valid.
 4. When connector is hot-plug and plug, T2 & T8 min spec can be 0ms.

Product Specification

4. Optical Specifications

Optical characteristics are determined after the unit has been 'ON' and stable for approximately 30 minutes in a dark environment at 25 ° C. The values specified are at an approximate distance 50cm from the LCD surface at a viewing angle of Φ and θ equal to 0 ° and aperture 1 degree.

FIG. 1 presents additional information concerning the measurement equipment and method.

FIG. 1 Optical Characteristic Measurement Equipment and Method

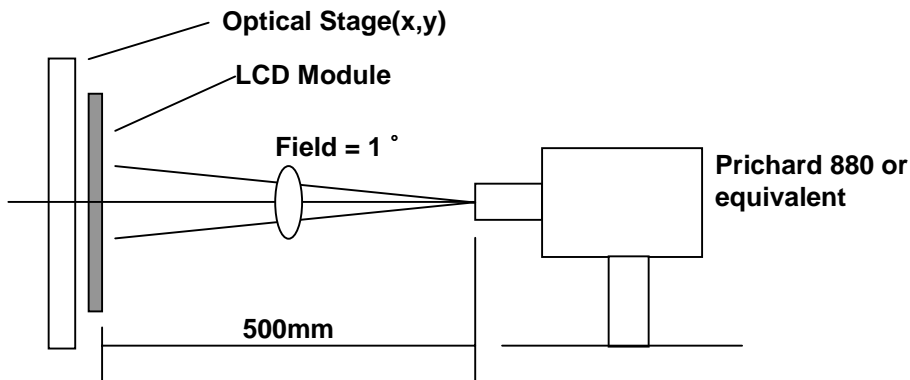

($T_a=25^\circ\text{C}$, $V_{CC}=18.0\text{V}$, $f_v=60\text{Hz}$
 $D_{clk}=156\text{MHz}$, $I_{BL}=7.5\text{mA}$)

Table 8. OPTICAL CHARACTERISTICS

Parameter	Symbol	Values			Units	Notes
		Min	Typ	MAx		
Contrast Ratio	CR	300	400			1
Surface Luminance, white	L_{WH}	170	200		cd/m ²	2
Luminance Variation	δ_{WHITE}			35%		3
Response Time	T_r		25	45	ms	4
Rise Time	T_{rR}		13	(23)		
Decay Time	T_{rD}		12	(22)		
Color Coordinates						
RED	RX	0.607	0.637	0.667		
RY	RY	0.300	0.330	0.360		
GREEN	GX	0.273	0.303	0.333		
GY	GY	0.556	0.586	0.616		
BLUE	BX	0.115	0.145	0.175		
BY	BY	0.040	0.070	0.100		
WHITE	WX	0.284	0.314	0.344		
WY	WY	0.301	0.331	0.361		
Viewing Angle						
x axis, right ($\phi=0^\circ$)	θ_r		85		degree	5
x axis, left ($\phi=180^\circ$)	θ_l		85			
y axis, up ($\phi=90^\circ$)	θ_u		85			
y axis, down ($\phi=270^\circ$)	θ_d		85			
Gray Scale			2.2			6

Product Specification

Notes : 1. Contrast Ratio(CR) is defined mathematically as :

$$\text{Contrast Ratio} = \frac{\text{Surface Luminance with all white pixels}}{\text{Surface Luminance with all black pixels}}$$

Contrast ratio shall be measured at the center of the display (Location P1).

2. Average Luminance (L_{WH}) is average of luminance value at location P1 to P5 with all pixels displaying white

$$L_{WH} = \frac{P1 + P2 + P3 + P4 + P5}{5}$$

3. The variation in surface luminance, δ WHITE is defined as

$$\delta \text{ WHITE} = \frac{\text{Maximum (P1, P2,P13)} - \text{Minimum (P1, P2,P13)}}{\text{Average(P1, P2,P5)}} \times 100$$

Where P1 to P13 are the luminance with all pixels displaying white at 13 locations.

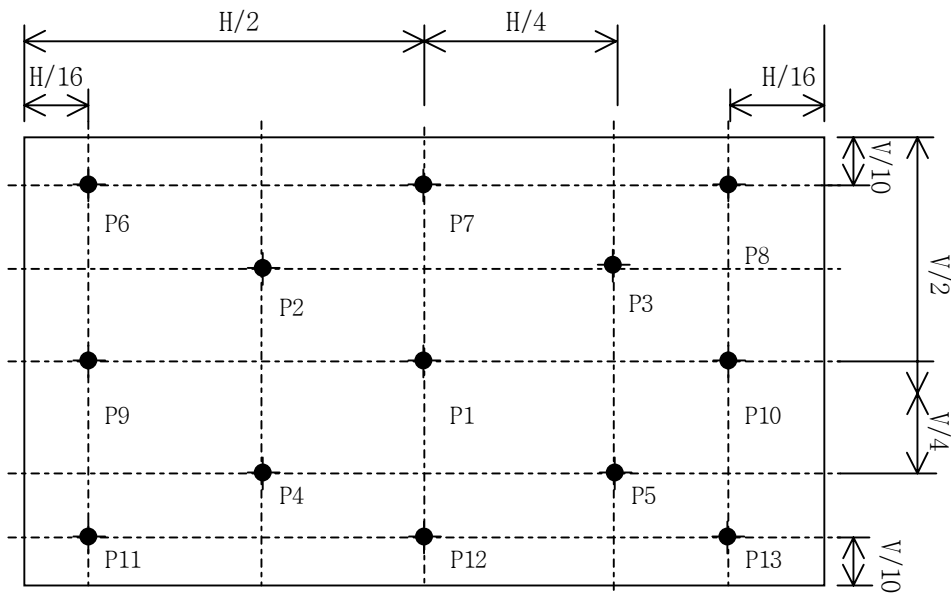

Product Specification

4. The response time is defined as the following figure and shall be measured by switching the input signal for "black" and "white".

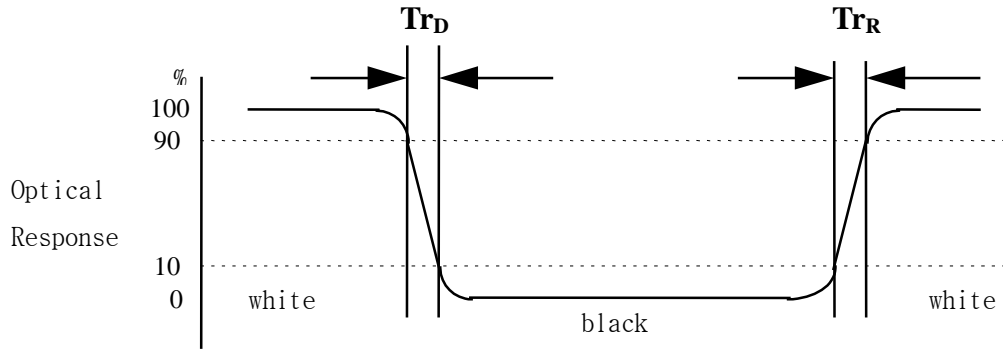

5. Viewing angle is the angle at which the contrast ratio is greater than 10.

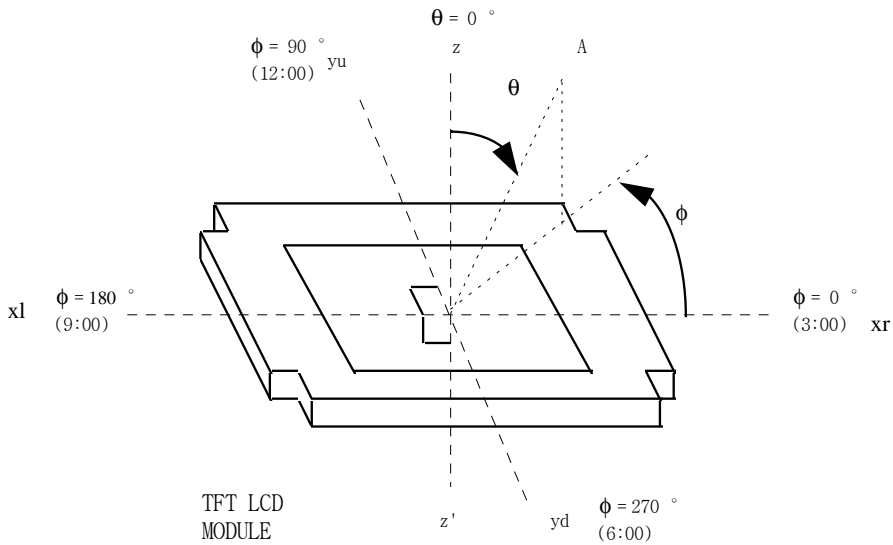

Product Specification

6. Grayscale Specification

Gray Level	Relative Luminance [%] (Typ.)
0	0.3
31	1.2
63	4.7
95	11.7
127	21.2
159	35.2
191	53.0
223	75.4
255	100

Product Specification

5. Mechanical Characteristics

The contents provide general mechanical characteristics for the model LM230W01. In addition the figures in the next page are detailed mechanical drawing of the LCD.

Outline Dimension	Horizontal	550.0 +0.7/-0.5mm
	Vertical	360.5 +0.7/-0.5mm
	Depth	25.0 ± 0.7mm
Bezel Area	Horizontal	499.4mm
	Vertical	313.6mm
Active Display Area	Horizontal	495.36mm
	Vertical	309.6mm
Weight	4500g (Typ.)	5000g (Max.)
Surface Treatment	Hard coating(3H) Anti-glare treatment of the front polarizer	

Product Specification

<REAR VIEW>

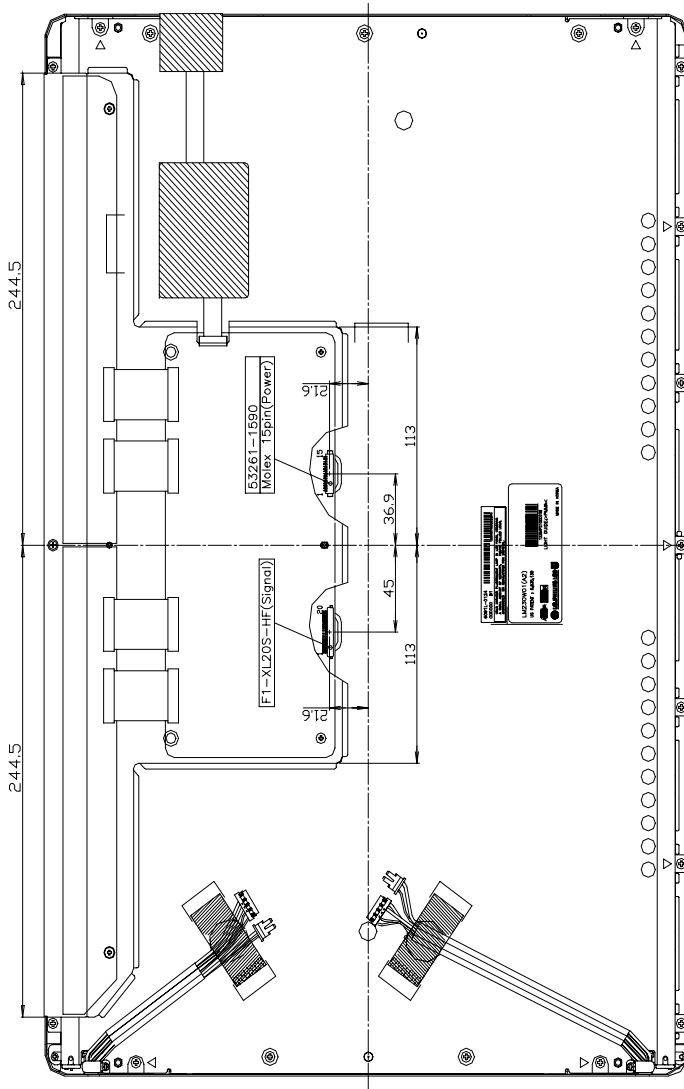

NOTES

1. Unspecified tolerances are to be $\pm 0.5\text{mm}$
2. Both backlight wires and contraction tubes are excluded from outline dimensions.
3. Tilt and partial disposition tolerance of display area are as following.
 - (1) Y-Direction : $|A-B| \leq 1.4\text{mm}$
 - (2) X-Direction : $|C-D| \leq 1.4\text{mm}$
4. Lamp(C CFL) lot No. is marked at backlight connector.

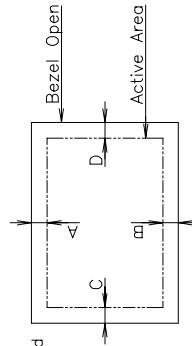
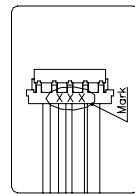

5. Do not wrap conductive tapes around the backlight wires.

Product Specification

6. Reliability

Environment test condition

No	Test Item	Condition
1	High temperature storage test	Ta= 60° C 240h
2	Low temperature storage test	Ta= -20° C 240h
3	High temperature operation test	Ta= 50° C 50%RH 240h
4	Low temperature operation test	Ta= 0° C 240h
5	Vibration test (non-operating)	Wave form : random Vibration level : 1.0G RMS Bandwidth : 10-500Hz Duration : X,Y,Z, 10 min One time each direction
6	Shock test (non-operating)	Shock level : 100G Waveform : half sine wave, 2ms Direction : ±X, ±Y, ±Z One time each direction
	Altitude storage / shipment	0 - 40,000 feet(12,192m)

{ Result Evaluation Criteria }

There should be no change which might affect the practical display function when the display quality test is conducted under normal operating condition.

Product Specification

7. International Standards

7-1. Safety

- a) UL 1950 Third Edition, Underwriters Laboratories, Inc. Jan. 28, 1995.
Standard for Safety of Information Technology Equipment Including Electrical Business Equipment.
- b) CAN/CSA C22.2 No. 950-95 Third Edition, Canadian Standards Association, Jan. 28, 1995.
Standard for Safety of Information Technology Equipment Including Electrical Business Equipment.
- c) EN 60950 : 1992+A1: 1993+A2: 1993+A3: 1995+A4: 1997+A11: 1997
IEC 950 : 1991+A1: 1992+A2: 1993+A3: 1995+A4: 1996
European Committee for Electrotechnical Standardization(CENELEC)
EUROPEAN STANDARD for Safety of Information Technology Equipment Including Electrical
Business Equipment.

7-2. EMC

- a) ANSI C63.4 "Methods of Measurement of Radio-Noise Emissions from Low-Voltage Electrical and Electrical Equipment in the Range of 9kHz to 40GHz." American National Standards Institute(ANSI), 1992
- b) C.I.S.P.R "Limits and Methods of Measurement of Radio Interface Characteristics of Information Technology Equipment." International Special Committee on Radio Interference
- c) EN 55022 "Limits and Methods of Measurement of Radio Interface Characteristics of Information Technology Equipment." European Committee for Electrotechnical Standardization (CENELEC), 1998

Product Specification

8. Packing

8-1. Designation of Lot Mark

a) Lot Mark

A	B	C	D	E	F	G	H	I	J	K	L	M
---	---	---	---	---	---	---	---	---	---	---	---	---

- A,B,C : SIZE
- D : YEAR
- E : MONTH
- F,G : PANEL CODE
- H : ASSEMBLY CODE
- I,J,K,L,M : SERIAL NO.

Note:

1. YEAR

YEAR	97	98	99	2000	2001	2002	2003	2004	2005	2006	2007
Mark	7	8	9	0	1	2	3	4	5	6	7

2. MONTH

MONTH	Jan.	Feb.	Mar.	Apr.	May.	Jun.	Jul.	Aug.	Sep.	Oct.	Nov.	Dec.
Mark	1	2	3	4	5	6	7	8	9	A	B	C

3. Serial No.

Serial No.	1 ~ 99999	100000 ~
Mark	00001 ~ 99999	A0001 ~ A9999,....., Z9999

b) Location of Lot Mark

Serial NO. is printed on the label. The label is attached to the backside of the LCD module.
This is subject to change without prior notice.

8-2. Packing Form

a) Package quantity in one box : 3 pcs

b) Box Size : TBD

Product Specification

9. PRECAUTIONS

Please pay attention to the following when you use this TFT LCD module.

9-1. MOUNTING PRECAUTIONS

- (1) You must mount a module using holes arranged in four corners or four sides.
- (2) You should consider the mounting structure so that uneven force(ex. Twisted stress) is not applied to the module.
And the case on which a module is mounted should have sufficient strength so that external force is not transmitted directly to the module.
- (3) Please attach a transparent protective plate to the surface in order to protect the polarizer.
Transparent protective plate should have sufficient strength in order to the resist external force.
- (4) You should adopt radiation structure to satisfy the temperature specification.
- (5) Acetic acid type and chlorine type materials for the cover case are not describe because the former generates corrosive gas of attacking the polarizer at high temperature and the latter causes circuit break by electro-chemical reaction.
- (6) Do not touch, push or rub the exposed polarizers with glass, tweezers or anything harder than HB pencil lead. And please do not rub with dust clothes with chemical treatment.
Do not touch the surface of polarizer for bare hand or greasy cloth.(Some cosmetics are determined to the polarizer.)
- (7) When the surface becomes dusty, please wipe gently with absorbent cotton or other soft materials like chamois soaks with petroleum benzene. Only IPS is recommended for cleaning the adhesives used to attach front / rear polarizers. Do not use acetone, toluene and alcohol because they cause chemical damage to the polarizer.
- (8) Wipe off saliva or water drops as soon as possible. Their long time contact with polarizer causes deformations and color fading.
- (9) Do not open the case because inside circuits do not have sufficient strength.

9-2. OPERATING PRECAUTIONS

- (1) The spike noise causes the mis-operation of circuits. It should be lower than following voltage :
 $V = \pm 200\text{mV}$ (Over and under shoot voltage)
- (2) Response time depends on the temperature.(In lower temperature, it becomes longer.)
- (3) Brightness depends on the temperature. (In lower temperature, it becomes lower.)
And in lower temperature, response time(required time that brightness is stable after turned on) becomes longer.
- (4) Be careful for condensation at sudden temperature change. Condensation makes damage to polarizer or electrical contacted parts. And after fading condensation, smear or spot will occur.
- (5) When fixed patterns are displayed for a long time, remnant image is likely to occur.
- (6) Module has high frequency circuits. Sufficient suppression to the electromagnetic interference shall be done by system manufacturers. Grounding and shielding methods may be important to minimized the interference.

Product Specification

9-3. ELECTROSTATIC DISCHARGE CONTROL

Since a module is composed of electronic circuits, it is not strong to electrostatic discharge. Make certain that treatment persons are connected to ground through wrist band etc. And don't touch interface pin directly.

9-4. PRECAUTIONS FOR STRONG LIGHT EXPOSURE

Strong light exposure causes degradation of polarizer and color filter.

9-5. STORAGE

When storing modules as spares for a long time, the following precautions are necessary.

- (1) Store them in a dark place. Do not expose the module to sunlight or fluorescent light. Keep the temperature between 5° C and 35° C at normal humidity.
- (2) The polarizer surface should not come in contact with any other object.
It is recommended that they be stored in the container in which they were shipped.

9-6. HANDLING PRECAUTIONS FOR PROTECTION FILM

- (1) The protection film is attached to the bezel with a small masking tape
When the protection film is peeled off, static electricity is generated between the film and polarizer.
This should be peeled off slowly and carefully by people who are electrically grounded and with well ion-blown equipment or in such a condition, etc.
- (2) When the module with protection film attached is stored for a long time, sometimes there remains a very small amount of glue still on the bezel after the protection film is peeled off.
- (3) You can remove the glue easily. When the glue remains on the bezel or its vestige is recognized, please wipe them off with absorbent cotton waste or other soft material like chamois soaked with normal-hexane.

Product Specification

APPENDIX 1 : Required Signal Assignment for TMDS

Graphics Controller		PanelLink		Flat Panel Controller	
24-bits	18-bits	Si1160	Si1161	18-bits	24-bits
B0 - 0		DIE0	QE0		B0 - 0
B1 - 0		DIE1	QE1		B1 - 0
B2 - 0	B0 - 0	DIE2	QE2	B0 - 0	B2 - 0
B3 - 0	B1 - 0	DIE3	QE3	B1 - 0	B3 - 0
B4 - 0	B2 - 0	DIE4	QE4	B2 - 0	B4 - 0
B5 - 0	B3 - 0	DIE5	QE5	B3 - 0	B5 - 0
B6 - 0	B4 - 0	DIE6	QE6	B4 - 0	B6 - 0
B7 - 0	B5 - 0	DIE7	QE7	B5 - 0	B7 - 0
G0 - 0		DIE8	QE8		G0 - 0
G1 - 0		DIE9	QE9		G1 - 0
G2 - 0	G0 - 0	DIE10	QE10	G0 - 0	G2 - 0
G3 - 0	G1 - 0	DIE11	QE11	G1 - 0	G3 - 0
G4 - 0	G2 - 0	DIE12	QE12	G2 - 0	G4 - 0
G5 - 0	G3 - 0	DIE13	QE13	G3 - 0	G5 - 0
G6 - 0	G4 - 0	DIE14	QE14	G4 - 0	G6 - 0
G7 - 0	G5 - 0	DIE15	QE15	G5 - 0	G7 - 0
R0 - 0		DIE16	QE16		R0 - 0
R1 - 0		DIE17	QE17		R1 - 0
R2 - 0	R0 - 0	DIE18	QE18	R0 - 0	R2 - 0
R3 - 0	R1 - 0	DIE19	QE19	R1 - 0	R3 - 0
R4 - 0	R2 - 0	DIE20	QE20	R2 - 0	R4 - 0
R5 - 0	R3 - 0	DIE21	QE21	R3 - 0	R5 - 0
R6 - 0	R4 - 0	DIE22	QE22	R4 - 0	R6 - 0
R7 - 0	R5 - 0	DIE23	QE23	R5 - 0	R7 - 0
B0 - 1		DIO0	QO0		B0 - 1
B1 - 1		DIO1	QO1		B1 - 1
B2 - 1	B0 - 1	DIO2	QO2	B0 - 1	B2 - 1
B3 - 1	B1 - 1	DIO3	QO3	B1 - 1	B3 - 1
B4 - 1	B2 - 1	DIO4	QO4	B2 - 1	B4 - 1
B5 - 1	B3 - 1	DIO5	QO5	B3 - 1	B5 - 1
B6 - 1	B4 - 1	DIO6	QO6	B4 - 1	B6 - 1
B7 - 1	B5 - 1	DIO7	QO7	B5 - 1	B7 - 1
G0 - 1		DIO8	QO8		G0 - 1
G1 - 1		DIO9	QO9		G1 - 1
G2 - 1	G0 - 1	DIO10	QO10	G0 - 1	G2 - 1
G3 - 1	G1 - 1	DIO11	QO11	G1 - 1	G3 - 1
G4 - 1	G2 - 1	DIO12	QO12	G2 - 1	G4 - 1
G5 - 1	G3 - 1	DIO13	QO13	G3 - 1	G5 - 1
G6 - 1	G4 - 1	DIO14	QO14	G4 - 1	G6 - 1
G7 - 1	G5 - 1	DIO15	QO15	G5 - 1	G7 - 1
R0 - 1		DIO16	QO16		R0 - 1
R1 - 1		DIO17	QO17		R1 - 1
R2 - 1	R0 - 1	DIO18	QO18	R0 - 1	R2 - 1
R3 - 1	R1 - 1	DIO19	QO19	R1 - 1	R3 - 1
R4 - 1	R2 - 1	DIO20	QO20	R2 - 1	R4 - 1
R5 - 1	R3 - 1	DIO21	QO21	R3 - 1	R5 - 1
R6 - 1	R4 - 1	DIO22	QO22	R4 - 1	R6 - 1
R7 - 1	R5 - 1	DIO23	QO23	R5 - 1	R7 - 1
Shift CLK	Shift CLK	IDCK	ODCK	Shift CLK	Shift CLK
VSYNC	VSYNC	VSYNC	VSYNC	VSYNC	VSYNC
HSYNC	HSYNC	HSYNC	HSYNC	HSYNC	HSYNC
DE	DE	DE	DE	DE	DE