



Patent Number : 61007 (R.O.C)
Patent Pending : 83216083 (R.O.C)

GENERAL DESCRIPTION

EM73962 is an advanced single chip CMOS 4-bit micro-controller. It contains 16K-byte ROM, 372-nibble RAM, 4-bit ALU, 13-level subroutine nesting, 22-stage time base, two 12-bit timer/counters for the kernel function. EM73962 also contains 5 interrupt sources, 3 I/O ports (including 1 input port and 2 bidirection ports), LCD display (40x8), built-in sound generator.

Except low-power consumption and high speed, EM73962 also have a sleep mode for power saving function. EM73962 is suitable for application in many fields, for example : family appliance, consumer products, hand held games and the toy controller ... etc.

FEATURES

- Operation voltage : 2.4V to 5.0V.
- Clock source : Single clock system for both RC and Crystal is available by mask option.
External clock and internal clock is available by mask option.
- Oscillation frequency : 480K, 1M, 2M and 4M Hz is available by mask option.
- Instruction set : 107 powerful instructions.
- Instruction cycle time : Up to 2us for 4 MHz.
- ROM capacity : 16384 X 8 bits.
- RAM capacity : 372 X 4 bits.
- Input port : 1 port (P0.0-P0.3) and sleep/hold releasing function are available by mask option.
(each input pin is pull-up and pull-down resistor available by mask option).
- Bidirection port : 2 ports (P4, P8). P4.0 and $\overline{\text{SOUND}}$ is available by mask option. P8(0..3) and sleep/hold releasing function are available by mask option.
- 12-bit timer/counter : Two 12-bit timer/counters are programmable for timer, event counter and pulse width measurement.
- Built-in time base counter : 22 stages.
- Subroutine nesting : Up to 13 levels.
- Interrupt : External 2 input interrupt sources.
Internal 2 Timer overflow interrupts.
1 Time base interrupt.
- LCD driver : 40 X 8 dots, 1/8 duty, LCD bias is 1/4 and 1/5 available by mask option, LCD bias resistor is 20K X 5 and 10K X 5 available by mask option.
- Sound effect : Tone generator, random generator and volume control.
- Power saving function : Sleep mode and Hold mode.
- Package type : EM73962H Chip form 68 pins.

FUNCTION BLOCK DIAGRAM

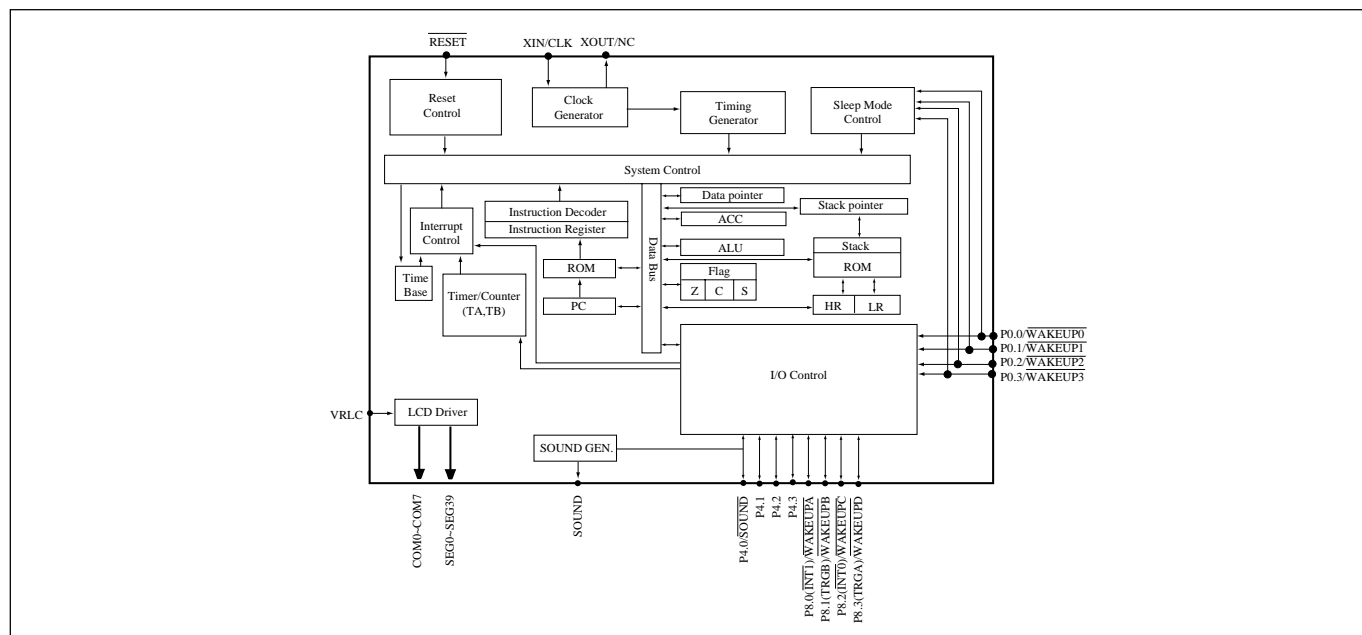

PIN DESCRIPTIONS

Symbol	Pin-type	Function
V_{DD}		Power supply (+)
V_{SS}		Power supply (-)
\overline{RESET}	RESET-A	System reset input signal, low active mask option : none pull-up
XIN/CLK	OSC-A/OSC-C	Crystal/RC or external clock source connecting pin
XOUT/NC	OSC-A/OSC-C	Crystal/RC connecting pin
$P0.(0..3)/\overline{WAKEUP0..3}$	INPUT-B	4-bit input port with Sleep/Hold releasing function mask option : wakeup enable, pull-up wakeup enable, none wakeup disable, pull-up wakeup disable, pull-down wakeup disable, none
$P4.0/\overline{SOUND}$	I/O-O	1-bit bidirection I/O port or inverse sound effect output mask option : \overline{SOUND} enable, push-pull, high current PMOS \overline{SOUND} disable, open-drain \overline{SOUND} disable, push-pull, high current PMOS \overline{SOUND} disable, push-pull, low current PMOS
P4(1..3)	I/O-N	3-bit bidirection I/O port with high current source. mask option : open-drain push-pull, high current PMOS push-pull, low current PMOS
$P8.0(\overline{INT1})/\overline{WAKEUPA}$ $P8.2(\overline{INT0})/\overline{WAKEUPC}$	I/O-L	2-bit bidirection I/O port with external interrupt sources input and Sleep/Hold releasing function mask option : wakeup enable, push-pull wakeup disable, push-pull wakeup disable, open-drain

Symbol	Pin-type	Function
P8.1(TRGB)/ $\overline{\text{WAKEUPB}}$	I/O-L	2-bit bidirection I/O port with time/counter A,B external input and Sleep /Hold releasing function
P8.3(TRGA)/ $\overline{\text{WAKEUPD}}$		
		mask option : wakeup enable, push-pull wakeup disable, push-pull wakeup disable, open-drain
SOUND		Built-in sound effect output
VRLC		LCD regulator voltage input
COM0~COM7		LCD common output pins
SEG0~SEG39		LCD segment output pins
TEST		Test pin must be connected to V_{SS}

FUNCTION DESCRIPTIONS

PROGRAM ROM (16K X 8 bits) for EM73962

16 K x 8 bits program ROM contains user's program and some fixed data .

The basic structure of program ROM can be divided into 4 parts.

1. Address 0000h: Reset start address.
2. Address 0002h - 000Ch : 5 kinds of interrupt service routine entry addresses .
3. Address 000Eh-0086h : SCALL subroutine entry address, only available at 000Eh,0016h,001Eh,0026h, 002Eh, 0036h, 003Eh, 0046h, 004Eh, 0056h, 005Eh, 0066h, 006Eh, 0076h, 007Eh, 0086h .
4. Address 0000h - 07FFh : LCALL subroutine entry address.
5. Address 0000h - 1FFFh : Except used as above function, the other region can be used as user's program region.

address Bank 0 :

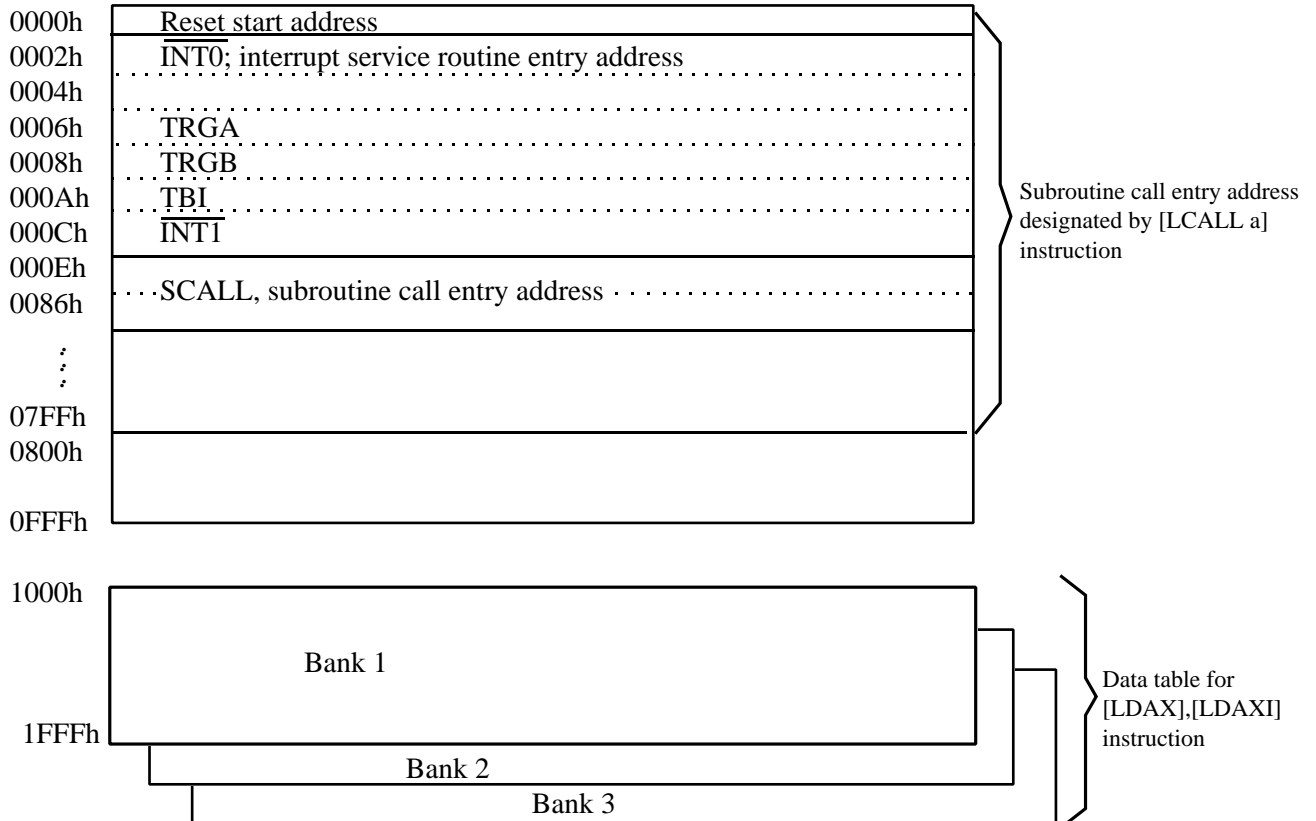

* This specification are subject to be changed without notice.

User's program and fixed data are stored in the program ROM. User's program is according the PC value to send next executed instruction code .

The 16Kx8 bits program ROM can be divided into 4 banks. There are 4Kx8 bits in each bank.

The bank of the program ROM is selected by P3(1..0). The program counter is a 13-bit binary counter. The PC and P3 are initialized to "0" during reset.

When P3(1..0)=00B, the bank0 and bank1 of program ROM will be selected. P3(1..0)=01B, the the bank0 and bank2 will be selected. P3(1..0)=10B, the bank0 and bank3 will be selected.

Address	P3=xx00B	P3=xx01B	P3=xx10b
0000h	Bank0	Bank0	Bank0
:			
:			
0FFFh	Bank1	Bank2	Bank3
1000h			
:			
:			
1FFFh			

PROGRAM EXAMPLE:

```

BANK 0
START:  :
        :
        :
        LDIA #00H           ; set program ROM to bank1
        OUTA P3
        B     XA1
        :
XA :    :
        :
        :
        LDIA #01H           ; set program ROM to bank2
        OUTA P3
        B     XB1
        :
XB :    :
        :
        :
        LDIA #02H           ; set program ROM to bank3
        OUTA P3
        B     XC1
        :
XC :    :
        :
        :
        B     XD
XD :    :
        :
        :
        :
-----
BANK 1
XA1 :   :
        :
        :
        B     XA
        :
XA2 :   :
    
```



Fixed data can be read out by table-look-up instruction. Table-look-up instruction is depended on the Data Pointer (DP) to ROM address, then to get the ROM code data :

LDAX **Acc** ← **ROM[DP]_L**
LDAXI **Acc** ← **ROM[DP]_H,DP+1**

DP is a 12-bit data register which can store the program ROM address to be the pointer for the ROM code data. First, user load ROM address into DP by instruction "LDADPL, LDADPM, LDADPH", then user can get the lower nibble of ROM code data by instruction "LDAX" and higher nibble by instruction "LDAXI"

PROGRAM EXAMPLE: Read out the ROM code of address 1777h by table-look-up instruction.

```

LDIA #07h;
STADPL ; [DP]L ← 07h
STADPM ; [DP]M ← 07h
STADPH ; [DP]H ← 07h, Load DP=777h
:
LDL #00h;
LDH #03h;
LDAX ; ACC ← 6h
STAMI ; RAM[30] ← 6h
LDAXI ; ACC ← 5h
STAM ; RAM[31] ← 5h
;
ORG 1777h
DATA 56h;
  
```

DATA RAM (372-nibble)

There is total 372 - nibble data RAM from address 000 to 17Fh
 Data RAM includes 3 parts: zero page region, stacks and data area.

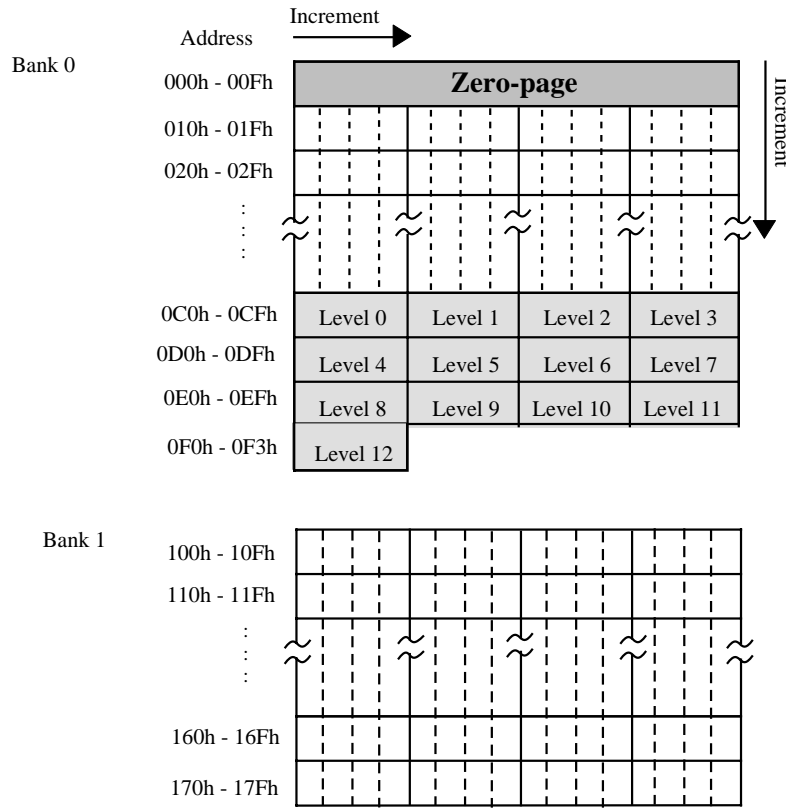

ZERO- PAGE:

From 000h to 00Fh is the location of zero-page . It is used as the pointer in zero -page addressing mode for the instruction of "STD #k,y; ADD #k,y; CLR y,b; CMP y,b".

PROGRAM EXAMPLE: To wirte immediate data "07h" to address "003h" of RAM and to clear bit 2 of RAM.
 STD #07h, 03h ; RAM[03] ← 07h
 CLR 0Eh,2 ; RAM[0Eh]₂ ← 0

STACK:

There are 13 - level (maximum) stack for user using for subroutine (including interrupt and CALL). User can assign any level be the starting stack by giving the level number to stack pointer(SP) .
 When user using any instruction of CALL or subroutine, before entry the subroutine, the previous PC address will be saved into stack until return from those subroutines ,the PC value will be restored by the data saved in stack.

DATA AREA:

Except the special area used by user, the whole RAM can be used as data area for storing and loading general data.

ADDRESSING MODE

The 372 nibble data memory consists of two banks (bank 0 and bank 1). There are 244x4 bits (address 000h~0F3h) on bank 0 and 128x4 bits (address 100h~17Fh) on bank 1.

There are three addressing modes in the data memory :

(1) Indirect addressing mode:

The bank is selected by P9.3. When P9.3 is cleared to "0", the bank 0 is selected.

When P9.3 is set to "1", the bank 1 is selected. The address in the bank are specified by the HL registers.

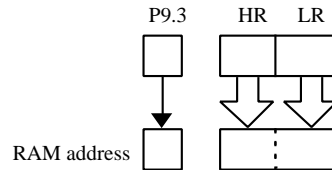

PROGRAM EXAMPLE: Load the data of RAM address "143h" to RAM address "023h".

```

SEP P9,3 ; P9.3← 1
LDL #3h ; LR← 3
LDH #4h ; HR← 4
LDAM ; Acc← RAM[134h]
CLP P9,3 ; P9.3← 0
LDL #2h ; LR← 2
LDH #3h ; HR← 3
STAM ; RAM[023h]← Acc
    
```

(2) Direct addressing mode:

The bank is selected by P9.3. When P9.3 is cleared to "0", the bank 0 is selected.

When P9.3 is set to "1", the bank 1 is selected. The address in the bank are directly specified by 8 bits of the second byte in the instruction field.

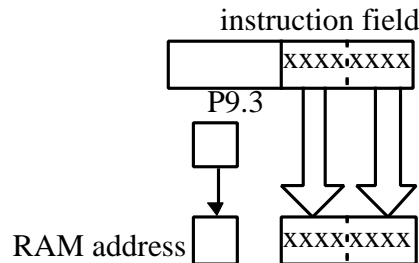

PROGRAM EXAMPLE: Load the data of RAM address "143h" to RAM address "023h".

```

SEP P9,3 ; P9.3← 1
LDA 43h ; Acc← RAM[134h]
CLP P9,3 ; P9.3← 0
STA 23h ; RAM[023h]← Acc
    
```

(3) Zero-page addressing mode:

The zero-page is the bank 0 (address 000h~00Fh). The address are the lower 4 bits of the second byte in the instruction field.

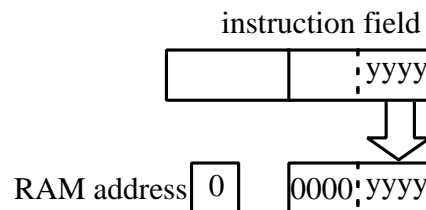

PROGRAM EXAMPLE: Write immediate "0Fh" to RAM address "005h".

```

STD #0Fh, 05h ; RAM[05h]← 0Fh
    
```

PROGRAM COUNTER (16K ROM) for EM73962

Program counter (PC) is composed by a 13-bit counter, which indicates the next executed address for the instruction of program ROM.

For a 8K - byte size ROM, PC can indicate address form 0000h - 1FFFh, for BRANCH and CALL instrcutions, PC is changed by instruction indicating.

(1) Branch instruction:

SBR a

Object code: 00aa aaaa

Condition: SF=1; PC ← PC_{12-6.a} (branch condition satisfied)

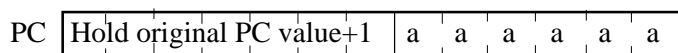

SF=0; PC← PC +1(branch condition not satisfied)

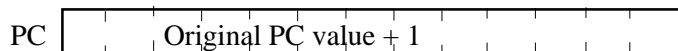

LBR a

Object code: 1100 aaaa aaaa aaaa

Condition: SF=1; PC ← PC_{12.a} (branch condition satisfied)

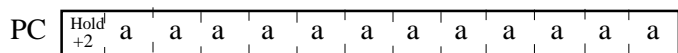

SF=0; PC← PC +2(branch condition not satisfied)

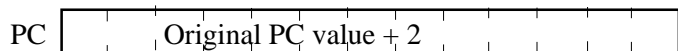

SLBR a

Object code: 0101 0101 1100 aaaa aaaa aaaa (a:1000h~1FFFh)

0101 0111 1100 aaaa aaaa aaaa (a:0000h~0FFFh)

Condition: SF=1; PC ← a (branch condition satisfied)

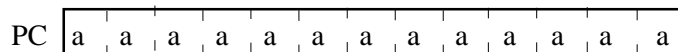

SF=0 ; PC ← PC + 3 (branch condition not satisfied)

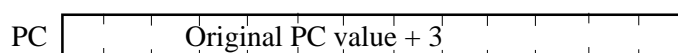

(2) Subroutine instruction:

SCALL a

Object code: 1110 nnnn

Condition : PC ← a ; a=8n+6 ; n=1..Fh ; a=86h, n=0

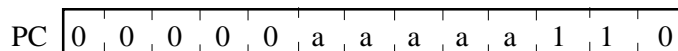

LCALL a

Object code: 0100 0aaa aaaa aaaa

Condition: PC ← a

PC

0	0	a	a	a	a	a	a	a	a	a	a	a
---	---	---	---	---	---	---	---	---	---	---	---	---

RET

Object code: 0100 1111

Condition: $PC \leftarrow STACK[SP]; SP + 1$

PC

The return address stored in stack												
------------------------------------	--	--	--	--	--	--	--	--	--	--	--	--

RTI

Object code: 0100 1101

Condition : FLAG. $PC \leftarrow STACK[SP]; EI \leftarrow 1; SP + 1$

PC

The return address stored in stack												
------------------------------------	--	--	--	--	--	--	--	--	--	--	--	--

(3) Interrupt acceptance operation:

When an interrupt is accepted, the original PC is pushed into stack and interrupt vector will be loaded into PC, The interrupt vectors are as following:

$\overline{INT0}$ (External interrupt from P8.2)

PC

0	0	0	0	0	0	0	0	0	0	0	0	1	0
---	---	---	---	---	---	---	---	---	---	---	---	---	---

TRGA (Timer A overflow interrupt)

PC

0	0	0	0	0	0	0	0	0	0	0	1	1	0
---	---	---	---	---	---	---	---	---	---	---	---	---	---

TRGB (Time B overflow interrupt)

PC

0	0	0	0	0	0	0	0	0	0	1	0	0	0
---	---	---	---	---	---	---	---	---	---	---	---	---	---

TBI (Time base interrupt)

PC

0	0	0	0	0	0	0	0	0	0	1	0	1	0
---	---	---	---	---	---	---	---	---	---	---	---	---	---

$\overline{INT1}$ (External interrupt from P8.0)

PC

0	0	0	0	0	0	0	0	0	0	1	1	0	0
---	---	---	---	---	---	---	---	---	---	---	---	---	---

(4) Reset operation:

PC

0	0	0	0	0	0	0	0	0	0	0	0	0	0
---	---	---	---	---	---	---	---	---	---	---	---	---	---

(5) Other operations:

For 1-byte instruction execution: $PC + 1$

For 2-byte instruction execution: $PC + 2$

For 3-byte instruction execution: $PC + 3$

ACCUMULATOR

Accumulator is a 4-bit data register for temporary data . For the arithmetic, logic and comparative operation ..., ACC plays a role which holds the source data and result .

FLAGS

There are three kinds of flag, CF (Carry flag), ZF (Zero flag), SF (Status flag), these 3 1-bit flags are affected by the arithmetic, logic and comparative operation .

All flags will be put into stack when an interrupt subroutine is served, and the flags will be restored after RTI instruction executed .

(1) Carry Flag (CF)

The carry flag is affected by following operation:

- a. Addition : CF as a carry out indicator, when the addition operation has a carry-out, CF will be "1", in another word, if the operation has no carry-out, CF will be "0".
- b. Subtraction : CF as a borrow-in indicator, when the subtraction operation must has a borrow, in the CF will be "0", in another word, if no borrow-in, CF will be "1".
- c. Comparison: CF is as a borrow-in indicator for Comparison operation as the same as subtraction operation.
- d. Rotation: CF shifts into the empty bit of accumulator for the rotation and holds the shift out data after rotation.
- e. CF test instruction : For TFCFC instruction, the content of CF sends into SF then clear itself "0". For TTSFC instruction, the content of CF sends into SF then set itself "1".

(2) Zero Flag (ZF)

ZF is affected by the result of ALU, if the ALU operation generate a "0" result, the ZF will be "1", otherwise, the ZF will be "0".

(3) Status Flag (SF)

The SF is affected by instruction operation and system status .

- a. SF is initiated to "1" for reset condition .
- b. Branch instruction is decided by SF, when SF=1, branch condition will be satisfied, otherwise, branch condition will not be satisfied by SF = 0 .

PROGRAM EXAMPLE:

Check following arithmetic operation for CF, ZF, SF

	CF	ZF	SF
LDIA #00h;	-	1	1
LDIA #03h;	-	0	1
ADDA #05h;	-	0	1
ADDA #0Dh;	-	0	0
ADDA #0Eh;	-	0	0

ALU

The arithmetic operation of 4 - bit data is performed in ALU unit . There are 2 flags can be affected by the result of ALU operation, ZF and SF . The operation of ALU can be affected by CF only .

ALU STRUCTURE

ALU supported user arithmetic operation function, including : addition, subtraction and rotaion.

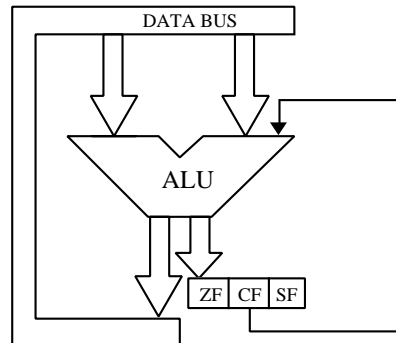

ALU FUNCTION

(1) Addition:

For instruction ADDAM, ADCAM, ADDM #k, ADD #k,y ALU supports addition function.

The addition operation can affect CF and ZF. For addition operation, if the result is "0", ZF will be "1", otherwise, not equal "0", ZF will be "0", When the addition operation has a carry-out. CF will be "1", otherwise, CF will be "0".

EXAMPLE:

Operation	Carry	Zero
3+4=7	0	0
7+F=6	1	0
0+0=0	0	1
8+8=0	1	1

(2) Subtraction:

For instruction SUBM #k, SUBA #k, SBCAM, DECM... ALU supports user subtraction function . The subtraction operation can affect CF and ZF, For subtraction operation, if the result is negative, CF will be "0", it means a borrow out, otherwise, if the result is positive, CF will be "1". For ZF, if the result of subtraction operation is "0", the ZF will be "1", otherwise, ZF will be "1".

EXAMPLE:

Operation	Carry	Zero
8-4=4	1	0
7-F= -8(1000)	0	0
9-9=0	1	1

(3) Rotation:

There are two kinds of rotation operation, one is rotation left, the other is rotation right.
RLCA instruction rotates Acc value to left, shift the CF value into the LSB bit of Acc and the shift out data will be hold in CF.

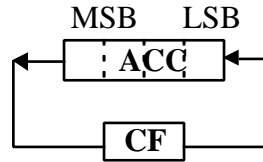

RRCA instruction operation rotates Acc value to right, shift the CF value into the MSB bit of Acc and the shift out data will be hold in CF.

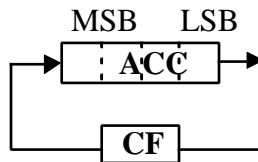

PROGRAM EXAMPLE: To rotate Acc right and shift a "1" into the MSB bit of Acc .

```
TTCFS; CF ← 1
RRCA; rotate Acc right and shift CF=1 into MSB.
```

HL REGISTER

HL register are two 4-bit registers, they are used as a pair of pointer for the address of RAM memory and also 2 independent temporary 4-bit data registers. For some instruction, L register can be a pointer to indicate the pin number (Port4) .

HL REGISTER STRUCTURE

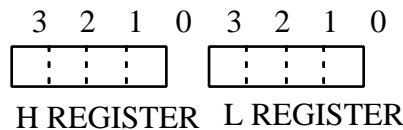

HL REGISTER FUNCTION

(1) For instruction : LDL #k, LDH #k, THA, THL, INCL, DECL, EXAL, EXAH, HL register used as a temporary register .

```
PROGRAM EXAMPLE: Load immediate data "5h" into L register, "Dh" into H register.
LDL #05h;
LDH #0Dh;
```

(2) For instruction LDAM, STAM, STAMI .., HL register used as a pointer for the address of RAM memory.

```
PROGRAM EXAMPLE: Store immediate data #Ah into RAM of address 35h.
```

```
LDL #5h;
LDH #3h;
STDMI #0Ah; RAM[35] ← Ah
```

(3) For instruction : SELP, CLPL, TFPL, L register be a pointer to indicate the bit of I/O port.

When LR = 0 indicate P4.0

PROGRAM EXAMPLE: To set bit 0 of Port4 to "1"

```
LDL #00h;
SEPL ; P4.0 ← 1
```

STACK POINTER (SP)

Stack pointer is a 4-bit register which stores the present stack level number.

Before using stack, user must set the SP value first, CPU will not initiate the SP value after reset condition .

When a new subroutine is accepted, the SP will be decreased one automatically, in another word, if returning from a subroutine, the SP will be increased one .

The data transfer between ACC and SP is by instruction of "LDASP" and "STASP".

DATA POINTER (DP)

Data pointer is a 12-bit register which stores the address of ROM can indicate the ROM code data specified by user (refer to data ROM).

CLOCK AND TIMING GENERATOR

The clock generator is supported by a single clock system, the clock source comes from crystal (resonator) or RC oscillation is decided by mask option, the working frequency range is 480 K Hz to 4 MHz depending on the working voltage.

CLOCK AND TIMING GENERATOR STRUCTURE

The clock generator connects outside components (crystal or resonator by XIN and XOUT pin for crystal osc. type, Resistor and capacitor by CLK pin for RC osc type, these two type is decided by mask option).

The clock generator generates a basic system clock "fc".

When CPU sleeping, the clock generator will be stoped until the sleep condition released.

The system clock control generates 4 basic phase signals (S1, S2, S3, S4) and system clock .

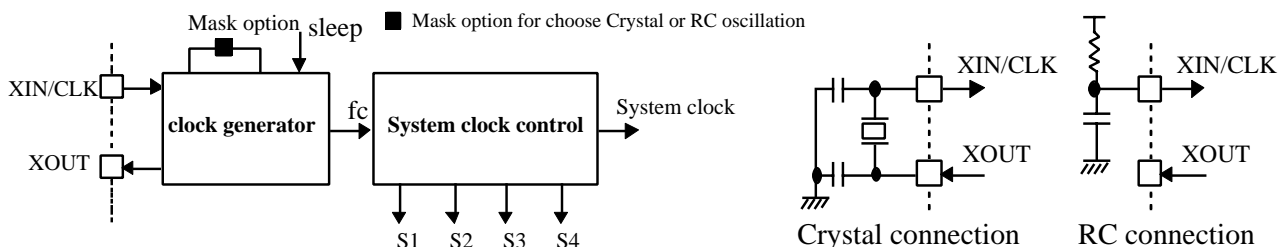

CLOCK AND TIMING GENERATOR FUNCTION

The frequency of fc is the oscillation frequency for XIN, XOUT by crystal (resonator) or for CLK by RC osc.

When CPU sleeps, the XOUT pin will be in "high" state . When user choose RC osc, XOUT pin is no used.
The instruction cycle equal 8 basic clock fc.

$$1 \text{ instruction cycle} = 8 / f_c$$

TIMING GENERATOR AND TIME BASE

The timing generator produces the system clock from basic clock pulse which can be normal mode or slow mode clock.

$$1 \text{ instruction cycle} = 8 \text{ basic clock pulses}$$

There are 22 stages time base .

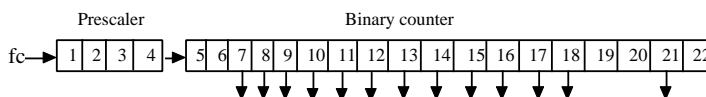

When working in the single clock mode, the timebase clock source is come from fc.

Time base provides basic frequency for following function:

1. TBI (time base interrupt) .
2. Timer/counter, internal clock source.
3. Warm-up time for sleep - mode releasing.

TIME BASE INTERRUPT (TBI)

The time base can be used to generate a fixed frequency interrupt . There are 8 kinds of frequencies can be selected by setting "P25"

Single clock mode

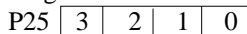

(initial value 0000)

- 0 0 x x: Interrupt disable
- 0 1 0 0: Interrupt frequency $XIN / 2^{10}$ Hz
- 0 1 0 1: Interrupt frequency $XIN / 2^{11}$ Hz
- 0 1 1 0: Interrupt frequency $XIN / 2^{12}$ Hz
- 0 1 1 1: Interrupt frequency $XIN / 2^{13}$ Hz
- 1 1 0 0: Interrupt frequency $XIN / 2^9$ Hz
- 1 1 0 1: Interrupt frequency $XIN / 2^8$ Hz
- 1 1 1 0: Interrupt frequency $XIN / 2^{15}$ Hz
- 1 1 1 1: Interrupt frequency $XIN / 2^{17}$ Hz
- 1 0 x x: Reserved

TIMER / COUNTER (TIMERA, TIMERB)

Timer/counters can support user three special functions:

1. Even counter
2. Timer.
3. Pulse-width measurement.

These three functions can be executed by 2 timer/counter independently.

For timerA, the counter data is saved in timer register TAH, TAM, TAL, which user can set counter initial value and read the counter value by instruction "LDATAH(M,L), STATAH(M,L)" and timer register is TBH, TBM, TBL and W/R instruction "LDATBH (M,L), STATBH (M,L)".

The basic structure of timer/counter is composed by two same structure counter, these two counters can be set initial value and send counter value to timer register, P28 and P29 are the command ports for timerA and timer B, user can choose different operation mode and different internal clock rate by setting these two ports. When timer/counter overflow, it will generate a TRGA(B) interrupt request to interrupt control unit.

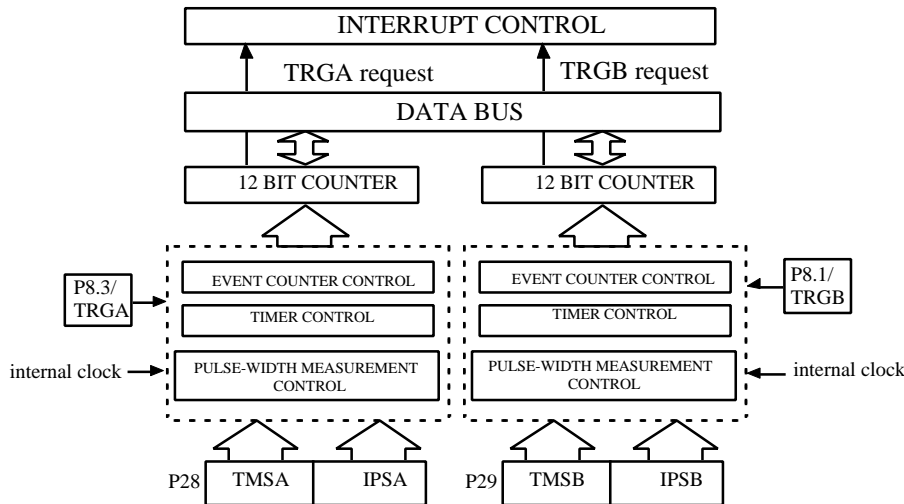

TIMER/COUNTER CONTROL

P8.1/TRGB, P8.3/TRGA are the external timer inputs for timerB and timerA, they are used in event counter and pulse-width measurement mode.

Timer/counter command port: P28 is the command port for timer/counterA and P29 is for the timer/counterB.

Port 28 <table border="1" style="margin-left: 40px; border-collapse: collapse;"> <tr> <td style="width: 20px; text-align: center;">3</td> <td style="width: 20px; text-align: center;">2</td> <td style="width: 20px; text-align: center;">1</td> <td style="width: 20px; text-align: center;">0</td> </tr> <tr> <td style="text-align: center;">TMSA</td> <td style="text-align: center;">IPSA</td> <td colspan="2"></td> </tr> </table> <p style="margin-left: 40px;">Initial state: 0000</p>	3	2	1	0	TMSA	IPSA			<table border="1" style="width: 100%; border-collapse: collapse;"> <thead> <tr> <th colspan="2" style="text-align: center;">TIMER/COUNTER MODE SELECTION</th> </tr> <tr> <th style="width: 20%;">TMSA (B)</th> <th style="width: 80%;">Function description</th> </tr> </thead> <tbody> <tr> <td style="text-align: center;">0 0</td> <td>Stop</td> </tr> <tr> <td style="text-align: center;">0 1</td> <td>Event counter mode</td> </tr> <tr> <td style="text-align: center;">1 0</td> <td>Timer mode</td> </tr> <tr> <td style="text-align: center;">1 1</td> <td>Pulse width measurement mode</td> </tr> </tbody> </table>	TIMER/COUNTER MODE SELECTION		TMSA (B)	Function description	0 0	Stop	0 1	Event counter mode	1 0	Timer mode	1 1	Pulse width measurement mode
3	2	1	0																		
TMSA	IPSA																				
TIMER/COUNTER MODE SELECTION																					
TMSA (B)	Function description																				
0 0	Stop																				
0 1	Event counter mode																				
1 0	Timer mode																				
1 1	Pulse width measurement mode																				
Port 29 <table border="1" style="margin-left: 40px; border-collapse: collapse;"> <tr> <td style="width: 20px; text-align: center;">3</td> <td style="width: 20px; text-align: center;">2</td> <td style="width: 20px; text-align: center;">1</td> <td style="width: 20px; text-align: center;">0</td> </tr> <tr> <td style="text-align: center;">TMSB</td> <td style="text-align: center;">IPSB</td> <td colspan="2"></td> </tr> </table> <p style="margin-left: 40px;">Initial state: 0000</p>	3	2	1	0	TMSB	IPSB			<table border="1" style="width: 100%; border-collapse: collapse;"> <thead> <tr> <th colspan="2" style="text-align: center;">INTERNAL PULSE-RATE SELECTION</th> </tr> <tr> <th style="width: 20%;">IPSA(B)</th> <th style="width: 80%;">Function description</th> </tr> </thead> <tbody> <tr> <td style="text-align: center;">0 0</td> <td>$XIN/2^{10}$ Hz</td> </tr> <tr> <td style="text-align: center;">0 1</td> <td>$XIN/2^{14}$ Hz</td> </tr> <tr> <td style="text-align: center;">1 0</td> <td>$XIN/2^{18}$ Hz</td> </tr> <tr> <td style="text-align: center;">1 1</td> <td>$XIN/2^{22}$ Hz</td> </tr> </tbody> </table>	INTERNAL PULSE-RATE SELECTION		IPSA(B)	Function description	0 0	$XIN/2^{10}$ Hz	0 1	$XIN/2^{14}$ Hz	1 0	$XIN/2^{18}$ Hz	1 1	$XIN/2^{22}$ Hz
3	2	1	0																		
TMSB	IPSB																				
INTERNAL PULSE-RATE SELECTION																					
IPSA(B)	Function description																				
0 0	$XIN/2^{10}$ Hz																				
0 1	$XIN/2^{14}$ Hz																				
1 0	$XIN/2^{18}$ Hz																				
1 1	$XIN/2^{22}$ Hz																				

TIMER/COUNTER FUNCTION

Timer/counterA can be programmable for timer, event counter and pulse width measurement. Each timer/counter can execute any one of these functions independently.

EVENT COUNTER MODE

For event counter mode, timer/counter increases one at any rising edge of P8.1/TRGB for timerB (P8.3/TRGA for timer A). When timerB (timerA) counts overflow, it will give interrupt control an interrupt request TRGB (TRGA).

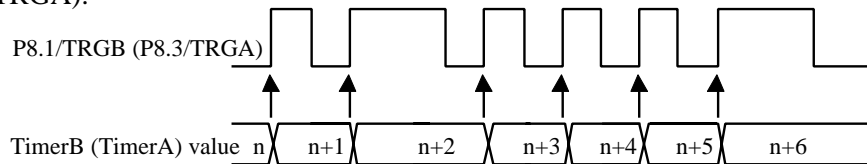

PROGRAM EXAMPLE: Enable timerA with P28

```
LDIA #0100B;
OUTA P28; Enable timerA with event counter mode
```

TIMER MODE

For timer mode, timer/counter increase one at any rising edge of internal pulse. User can choose 4 kinds of internal pulse rate by setting IPSB for timerB (IPSA for timerA).

When timer/counter counts overflow, TRGB (TRGA) will be generated to interrupt control unit.

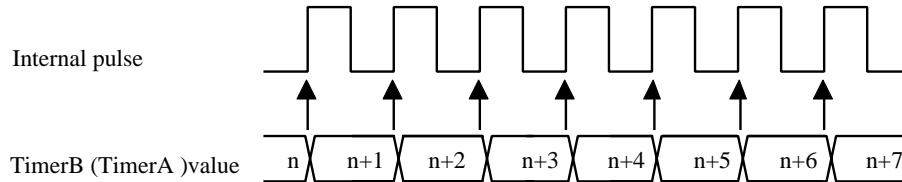

PROGRAM EXAMPLE: To generate TRGA interrupt request after 60 ms with system clock XIN=4MHz

```
LDIA #0100B;
EXAE; enable mask 2
EICIL 110111B; interrupt latch ←0, enable EI
LDIA #06H;
STATAL;
LDIA #01H;
STATAM;
LDIA #0FH;
STATAH;
LDIA #1000B;
OUTA P28; enable timerA with internal pulse rate: XIN/210 Hz
```

NOTE: The preset value of timer/counter register is calculated as following procedure.

Internal pulse rate: $XIN/2^{10}$; $XIN = 4\text{MHz}$

The time of timer counter count one = $2^{10}/XIN = 1024/4000 = 0.256\text{ms}$

The number of internal pulse to get timer overflow = $60\text{ ms} / 0.256\text{ms} = 234.375 = 0\text{EAH}$

The preset value of timer/counter register = $1000\text{H} - 0\text{EAH} = 0\text{F16H}$

PULSE WIDTH MEASUREMENT MODE

For the pulse width measurement mode, the counter only increased by the rising edge of internal pulse rate as external timer/counter input (P8.1/TRGB, P8.3/TRGA), interrupt request will be generated as soon as timer/counter count overflow.

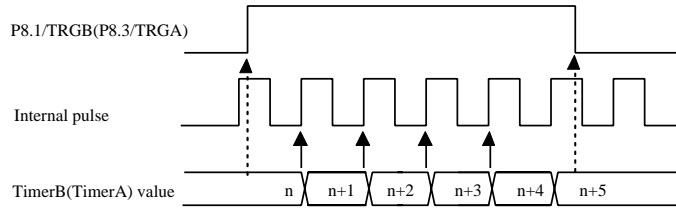

PROGRAM EXAMPLE: Enable timerA by pulse width measurement mode .
 LDIA #1100b;
 OUTA P28; Enable timerA with pulse width measurement mode.

INTERRUPT FUNCTION

There are 5 interrupt sources, 2 external interrupt sources, 3 internal interrupt sources . Multiple interrupts are admitted according the priority .

Type	Interrupt source	Priority	Interrupt Latch	Interrupt Enable condition	Program ROM entry address
External	External interrupt($\overline{INT0}$)	1	IL5	EI=1	002h
Internal	Reserved	2	IL4	EI=1, MASK3=1	004h
Internal	TimerA overflow interrupt (TRGA)	3	IL3	EI=1, MASK2=1	006h
Internal	TimerB overflow interrupt (TRGB)	4	IL2	EI=1, MASK1=1	008h
Internal	Time base interrupt(TBI)	5	IL1		00Ah
External	External interrupt(INT1)	6	IL0	EI=1, MASK0=1	00Ch

INTERRUPT STRUCTURE

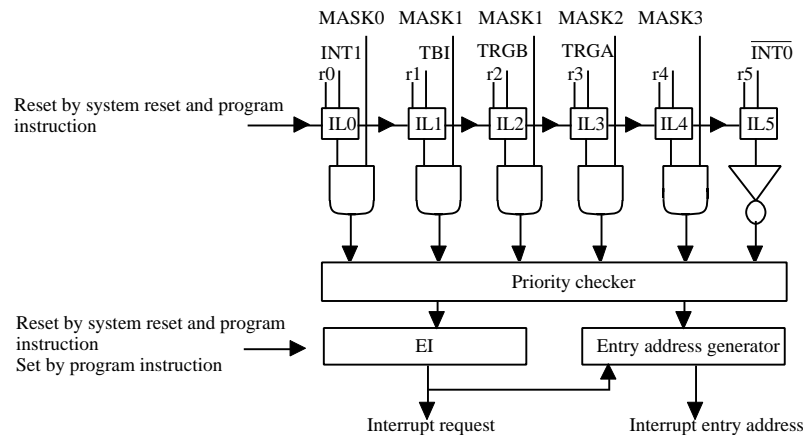

Interrupt controller:

IL0-IL5 : Interrupt latch . Hold all interrupt requests from all interrupt sources. ILr can not be set by program, but can be reset by program or system reset, so IL only can decide which interrupt source can be accepted.

MASK0-MASK3 : Except $\overline{INT0}$,MASK register can permit or inhibit all interrupt sources.

EI : Enable interrupt Flip-Flop can permit or inhibit all interrupt sources, when interrupt happened, EI is cleared to "0" automatically, after RTI instruction happened, EI will be set to "1" again .

Priority checker: Check interrupt priority when multiple interrupts happened.

INTERRUPT FUNCTION

The procedure of interrupt operation:

1. Push PC and all flags to stack.
2. Set interrupt entry address into PC.
3. Set SF= 1.
4. Clear EI to inhibit other interrupts happened.
5. Clear the IL for which interrupt source has already be accepted.
6. To excute interrupt subroutine from the interrupt entry address.
7. CPU accept RTI, restore PC and flags from stack . Set EI to accept other interrupt requests.

PROGRAM EXAMPLE: To enable interrupt of "INT0, TRGA"

```
LDIA #1100B;
EXAE; set mask register "1100B"
EICIL 111111B ; enable interrupt F.F.
```

POWER SAVING FUNCTION (Sleep / Hold function)

During sleep and hold condition, CPU holds the system’s internal status with a low power consumption, for the sleep mode, the system clock will be stoped in the sleep condition and system need a warm up time for the stability of system clock running after wakeup . In the other way, for the hold mode, the system clock does not stop at all and it does not need a warm-up time any way.

The sleep and hold mode is controlled by Port 16 and released by P0(0..3)/WAKEUP0..3 or P8(0..3)/WAKEUPA..D.

P16	3	2	1	0	initial value :0000
WM	SE	SWWT			

WM	Set wake-up release mode
0	Wake-up in edge release mode
1	Wake-up in level release mode

SWWT	Set wake-up warm-up time
0 0	$2^{18} / XIN$
0 1	$2^{14} / XIN$
1 0	$2^{16} / XIN$
1 1	Hold mode

SE	Enable sleep/hold
0	Reserved
1	Enable sleep / hold mode

Sleep and hold condition:

1. Osc stop (sleep only) and CPU internal status held .
2. Internal time base clear to "0".
3. CPU internal memory ,flags, register, I/O held original states.
4. Program counter hold the executed address after sleep release.

Release condition:

1. Osc start to oscillating.(sleep only).
2. Warm-up time passing (sleep only).
3. According PC to execute the following program.

There is one kind of sleep/hold release mode .

1. Edge release mode:

Release sleep/hold condition by the falling edge of any one of P0(0..3)/WAKEUP0..3 or P8(0..3)/WAKEUPA..D.

Note : There are 8 independent mask options for wakeup function in EM73962. So, the wakeup function of P0(0..3)/WAKEUP0..3 and P8(0..3)/WAKEUPA..D are enabled or disabled independently.

LCD DRIVER

It can directly drive the liquid crystal display (LCD) and has 40 segments , 8 commons output pins. There are total 40x8 dots can be display. The VRLC pin is the LCD driver power input, there is the voltage of (Vcc - VRLC) to LCD .

(1) LCD driver control command register:

Port27 3 2 1 0 Initial value: 0h

LDC	*	*
LCD DISPLAY CONTROL		
LDC	Function description	
0 0	LCD display disable	
0 1	Blanking, change COMMON pin output	
1 0	Reserved	
1 1	LCD display enable	

* : Don't care .

P27 is the LDC driver control command register . The initial value is 0000 .

When LDC (bit2 and bit3 of P27) is set to “00”, the LCD display is disabled .

When LDC is set to “01”, the LCD is blanking, the COM pins are inactive and the SEG pins continuously output the display data .

The power switch of LCD driver is turned off when the CPU is reseted .

When LDC is set to “11”, the LCD display is enabled, the power switch is turned on and it can not be turned off forever except the CPU is reseted again .

The power switch is also turned off during the sleep operation . Users must enable the LCD display again by self when the CPU is waked up .

(2) LCD display data area:

The LCD display data is stored in the display data area of the data memory (RAM) .

The display data area begins with address 20H during reset . The LCD display data area is as below:

RAM	0	1	2	3	4	5	6	7	8	9	A	B	C	D	E	F
20H				C	O	M	0									
30H				C	O	M	1									
40H				C	O	M	2									
50H				C	O	M	3									
60H				C	O	M	4									
70H				C	O	M	5									
80H				C	O	M	6									
90H				C	O	M	7									

SSSS SSSS SSSS SSSS SSSS SSSS SSSS SSSS SSSS SSSS

EEEE EEEEEEEEE EEEE EEEE EEEE EEEE EEEE EEEE

GGGG GGGGGGGG GGGG GGGG GGGG GGGG GGGG GGGG

0123 4567 8911 1111 1111 2222 2222 2233 3333 3333

01 2345 6789 0123 4567 8901 2345 6789

bbbb

iiii

tttt

0123

Read automatically the display data from the display data area and send to the LCD driver by the hardware . Therefore, the display patterns can be changed only by overwriting the contents of the display data area with the software .

The data memory which is not used to store the LCD display data and the addresses are not connected to the LCD can be used to store the ordinary user's processing data .

PROGRAM EXAMPLE:

```
LDIA #1100B    ; LCD display enable
OUTA P27
LDIA #1010B
STA 24H
```

(3) LCD waveform : (1/5 bias)

(3) LCD waveform :

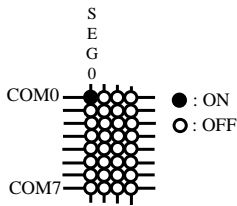

BIAS	Modify 1/4	1/4
VDD/(VDD-VRLC)	1	1
V4/(VDD-VRLC)	17/23	/
V3/(VDD-VRLC)	12/23	3/4
V2/(VDD-VRLC)	11/23	1/2
V1/(VDD-VRLC)	6/23	1/4
VRLC/(VDD-VRLC)	0	0

* TYPE A, modify 1/4 bias :

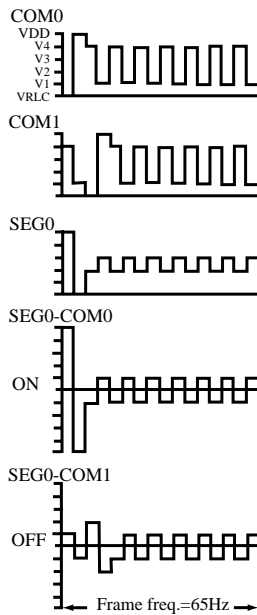

* TYPE B, modify 1/4 bias :

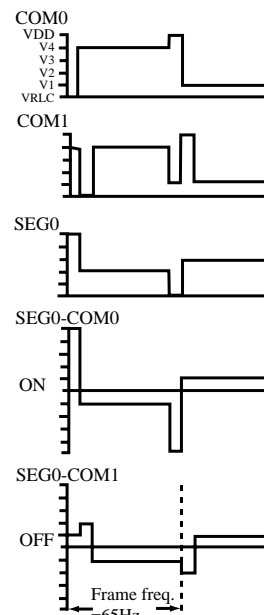

* TYPE A, 1/4 bias :

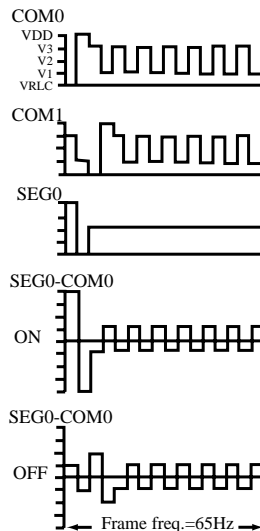

* TYPE B, 1/4 bias :

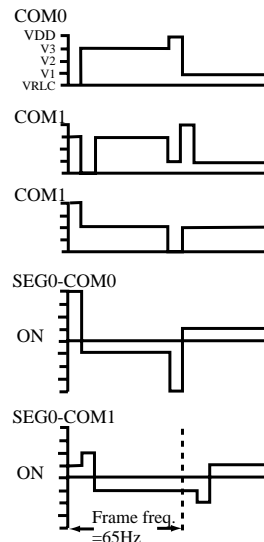

SOUND EFFECT

EM73962 has a built-in sound generator. It includes the tone generator, random generator and volume control. The tone generator is a binary down counter and the random generator is a 9-bit linear feedback shift register. When the CPU is reseted or sleeping, the sound generator is disabled and the output (P4.0/SOUND) is high .

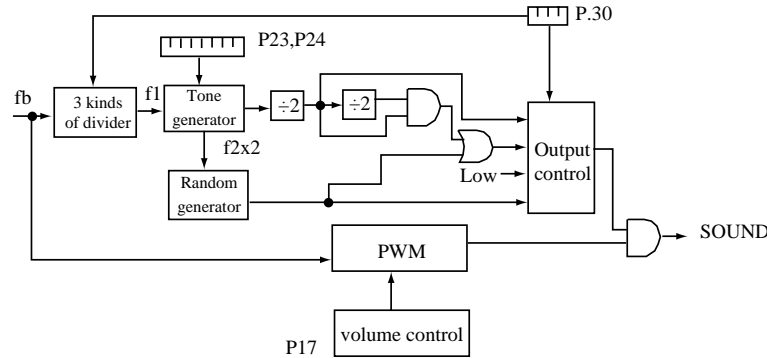

Sound generator command register

There are 3 kinds of basic frequency for sound generator which can be selected by P30. The output of sound effect is tone and random combination.

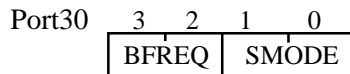

Initial value : 0000

BFREQ	Basic frequency (f1) select
0 0	240 KHz
0 1	120 KHz
1 0	60 KHz
1 1	don't care

SMODE	Sound generator mode
0 0	Disable
0 1	Tone output
1 0	Random output
1 1	Tone+random output

Tone frequency register

The 8-bit tone frequency register is P24 and P23. The tone frequency will be changed when user output the different data to P23. Thus, the data must be output to P24 before P23 when user want to change the 8-bit tone frequency (TF).

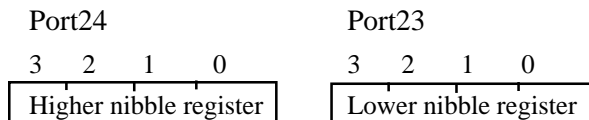

Initial value : 1111 1111

** $f1=240K/2^x$, $f2=f1/(TF+1)/2$, $TF=1\sim255$, $TF\neq0$

** Example : BFREQ=10, TF=00110001B.

⇒ $f1=60K\text{ Hz}$, $f2=60K\text{ Hz}/50/2=600\text{ Hz}$

Random generator

$$f(x)=x^9+x^4+1$$

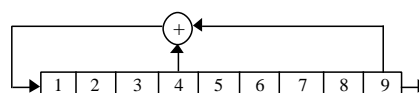

Volume control register

The are 8 levels of volume for sound generator. P17 is the volume control register.

Port17

Initial value : * 1111

3	2	1	0	
* VCR				
VCR				ts/tp
1	1	1		8/8
1	1	0		7/8
1	0	1		6/7
1	0	0		5/8
0	1	1		4/8
0	1	0		3/8
0	0	1		2/8
0	0	0		1/8

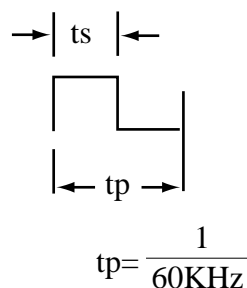

PROGRAM EXAMPLE:

```
LDIA #1001B ; basic frequency : 60 KHz tone output
OUTA P30
LDIA #0011B ; 600 Hz tone output
OUTA P24
LDIA #0001B
OUTA P23
```

RESETTING FUNCTION

When CPU in normal working condition and RESET pin holds in low level for three instruction cycles at least, then CPU begins to initialize the whole internal states, and when RESET pin changes to high level, CPU begins to work in normal condition.

The CPU internal state during reset condition is as following table :

Hardware condition in RESET (f1) state	Initial value
Program counter	0000h
Status flag	01h
Interrupt enable flip-flop (EI)	00h
MASK0 ,1, 2, 3	00h
Interrupt latch (IL)	00h
P3, P9, 16, 25, 27, 28, 29, 30	00h
P4, 8, 17, 23, 24	0Fh
XIN	Start oscillation

The RESET pin is a hysteresis input pin and it has a pull-up resistor available by mask option. The simplest RESET circuit is connect RESET pin with a capacitor to V_{SS} and a diode to V_{DD} .

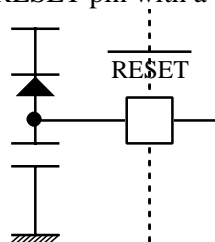

EM73962 I/O PORT DESCRIPTION :

Port	Input function	Output function	Note
0	E Input port , wakeup function		
1	--	--	
2	--	--	
3	--	I P3(1..0) : ROM bank selection	
4	E input port	E Output port, P4.0/SOUND	
5	--	--	
6	--	--	
7	--	--	
8	E Input port, wakeup function, external interrupt input	E Output port	
9	--	I P9.3 : RAM bank selection	
10	--	--	
11	--	--	
12	--	--	
13	--	--	
14	--	--	
15	--	--	
16		I Sleep/Hold mode control register	
17		I Sound effect volume control register	
18		--	
19		--	
20		--	
21		--	
22		--	
23		I Sound effect frequency register	low nibble
24		I Sound effect command register	high nibble
25		I Timebase control register	
26		--	
27		I LCD control register	
28		I Timer/counter A control register	
29		I Timer/counter B control register	
30		I Sound effect command register	
31		--	

ABSOLUTE MAXIMUM RATINGS

Items	Sym.	Ratings	Conditions
Supply Voltage	V_{DD}	-0.5V to 6V	
Input Voltage	V_{IN}	-0.5V to $V_{DD}+0.5V$	
Output Voltage	V_O	-0.5V to $V_{DD}+0.5V$	
Power Dissipation	P_D	300mW	$T_{OPR}=50^{\circ}C$
Operating Temperature	T_{OPR}	0°C to 50°C	
Storage Temperature	T_{STG}	-55°C to 125°C	

RECOMMENDED OPERATING CONDITIONS

Items	Sym.	Ratings	Condition
Supply Voltage	V_{DD}	2.4V to 5.0V	
Input Voltage	V_{IH}	$0.90 \times V_{DD}$ to V_{DD}	
	V_{IL}	0V to $0.10 \times V_{DD}$	
Operating Frequency	F_C	480K to 4MHz	CLK (RC osc)
		480K to 4.19MHz	XIN,XOUT (crystal osc)

DC ELECTRICAL CHARACTERISTICS ($V_{DD}=3\pm 0.3V$, $V_{SS}=0V$, $T_{OPR}=25^{\circ}C$)

Parameters	Sym.	Min.	Typ.	Max.	Unit	Conditions
Supply current	I_{DD}	-	0.7	2	mA	$V_{DD}=3.3V$, no load, $F_c=4MHz$ (RC osc : $R=6.2K\Omega$, $C=20pF$)
		-	0.1	1	μA	$V_{DD}=3.3V$, sleep mode
Hysteresis voltage	V_{HYS+}	$0.5V_{DD}$	-	$0.75V_{DD}$	V	RESET, P0, P8
	V_{HYS-}	$0.2V_{DD}$	-	$0.4V_{DD}$	V	
Input current	I_{IH}	-	-	± 1	μA	P0, RESET, $V_{DD}=3.3V$, $V_{IH}=3.3/0V$
		-	-	± 1	μA	Open-drain, $V_{DD}=3.3V$, $V_{IH}=3.3/0V$
	I_{IL}	-	-	-500	μA	Push-pull, $V_{DD}=3.3V$, $V_{IL}=0.4V$, except P4
Output voltage	V_{OH}	2.4	-	-	V	Push-pull, $V_{DD}=2.7V$, P4 (high current PMOS), SOUND, $I_{OH}=-0.9mA$
		2.0	-	-	V	Push-pull, $V_{DD}=2.7V$, others, $I_{OH}=-40\mu A$
	V_{OL}	-	-	0.3	V	$V_{DD}=2.7V$, $I_{OL}=0.9mA$
Leakage current	I_{LO}	-	-	1	μA	Open-drain, $V_{DD}=3.3V$, $V_O=3.3V$
Input resistor	R_{IN}	100	200	300	$K\Omega$	P0
		300	600	900	$K\Omega$	RESET
Frequency stability		-	15	-	%	$F_c=4MHz$, RC osc, $[F(3V)-F(2.4V)]/F(3V)$
Frequency variation		-	20	-	%	$F_c=4MHz$, $V_{DD}=3V$, RC osc, $[F(\text{typical})-F(\text{worse case})]/F(\text{typical})$

$(V_{DD}=4.5\pm 0.5V, V_{SS}=0V, T_{OPR}=25^{\circ}C)$

Parameters	Sym.	Min.	Typ.	Max.	Unit	Conditions
Supply current	I_{DD}	-	4.5	5.5	mA	$V_{DD}=5V$, no load, $F_c=4.19MHz$ (crystal osc)
		-	1.5	2	mA	$V_{DD}=5V$, no load, $F_c=4MHz$ (RC osc : $R=7.5K\Omega$, $C=20pF$)
		-	0.1	1	μA	$V_{DD}=5V$, sleep mode
Hysteresis voltage	V_{HYS+}	$0.5V_{DD}$	-	$0.75V_{DD}$	V	\overline{RESET} , P0, P8
	V_{HYS-}	$0.2V_{DD}$	-	$0.4V_{DD}$	V	
Input current	I_{IH}	-	-	± 1	μA	P0, \overline{RESET} , $V_{DD}=5V, V_{IH}=5/0V$
		-	-	± 1	μA	Open-drain, $V_{DD}=5V, V_{IH}=5/0V$
	I_{IL}	-	-	-1	mA	Push-pull, $V_{DD}=5V, V_{IL}=0.4V$, except P4
Output voltage	V_{OH}	3.0	-	-	V	Push-pull, P4(high current PMOS), SOUND $V_{DD}=4V, I_{OH}=-4mA$
		2.4	-	-	V	Push-pull, P4(low current PMOS), P8 $V_{DD}=4V, I_{OH}=-200\mu A$
	V_{OL}	-	-	1.0	V	$V_{DD}=4V, I_{OL}=4mA$
Leakage current	I_{LO}	-	-	1	μA	Open-drain, $V_{DD}=5V, V_o=5V$
Input resistor	R_{IN}	30	90	150	$K\Omega$	P0
		100	300	450	$K\Omega$	\overline{RESET}
Frequency stability		-	10	-	%	$F_c=4MHz, RC_{osc}, [F(4.5V)-F(3.6V)]/F(4.5V)$
Frequency variation		-	20	-	%	$F_c=4MHz, V_{DD}=4.5V, RC_{osc}, [F(\text{typical})-F(\text{worse case})]/F(\text{typical})$

RESET PIN TYPE

TYPE RESET-A

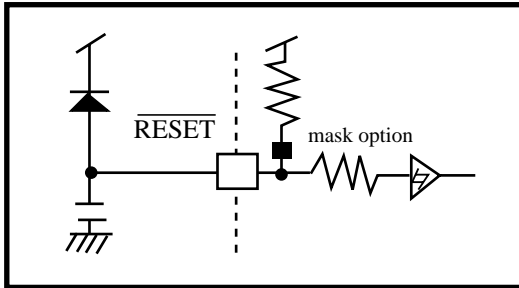

OSCILLATION PIN TYPE

TYPE OSC-A

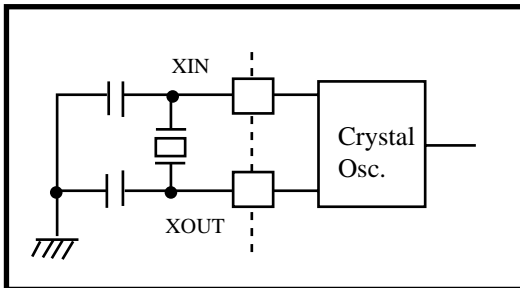

TYPE OSC-C

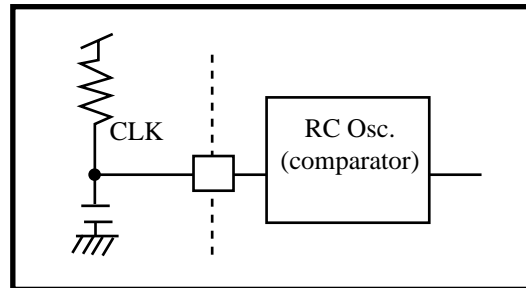

INPUT PIN TYPE

TYPE INPUT-A

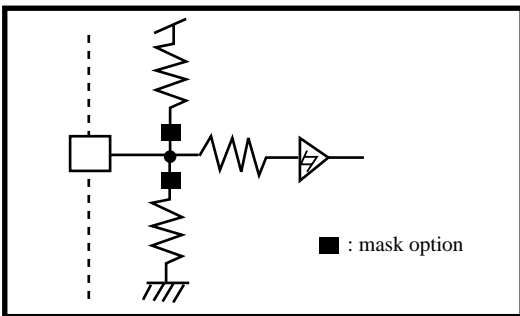

TYPE INPUT-B

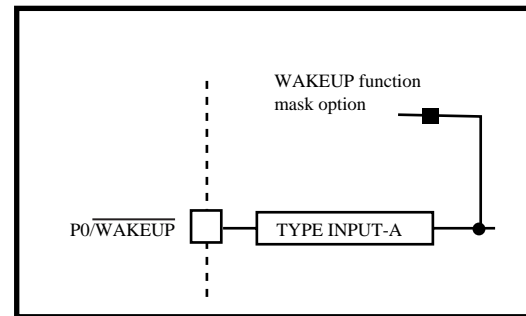

I/O PIN TYPE

TYPE I/O

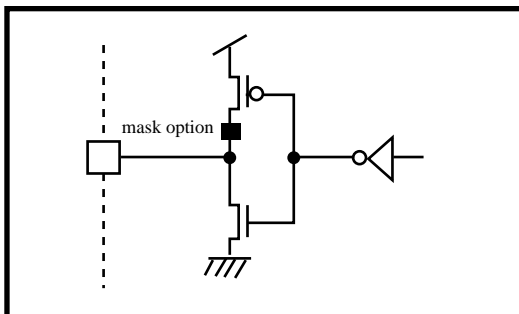

TYPE I/O-L

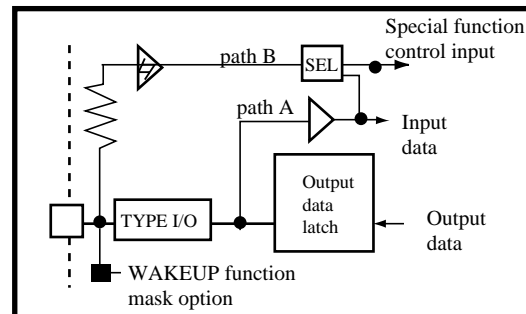

TYPE I/O-N

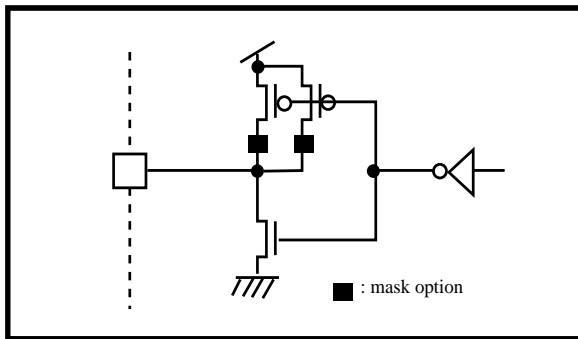

TYPE I/O-O

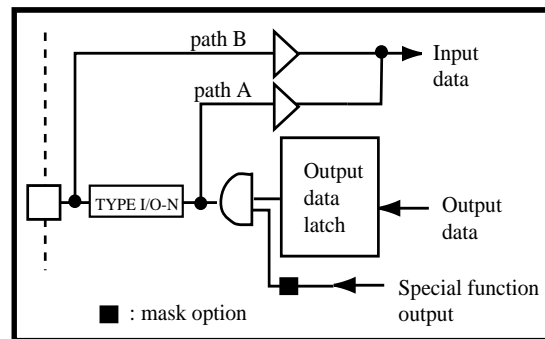

- Path A : For set and clear bit of port instructions, data goes through path A from output data latch to CPU.
- Path B : For input and test instructions, data from output pin go through path B to CPU and the output data latch will be set to high.

PAD DIAGRAM

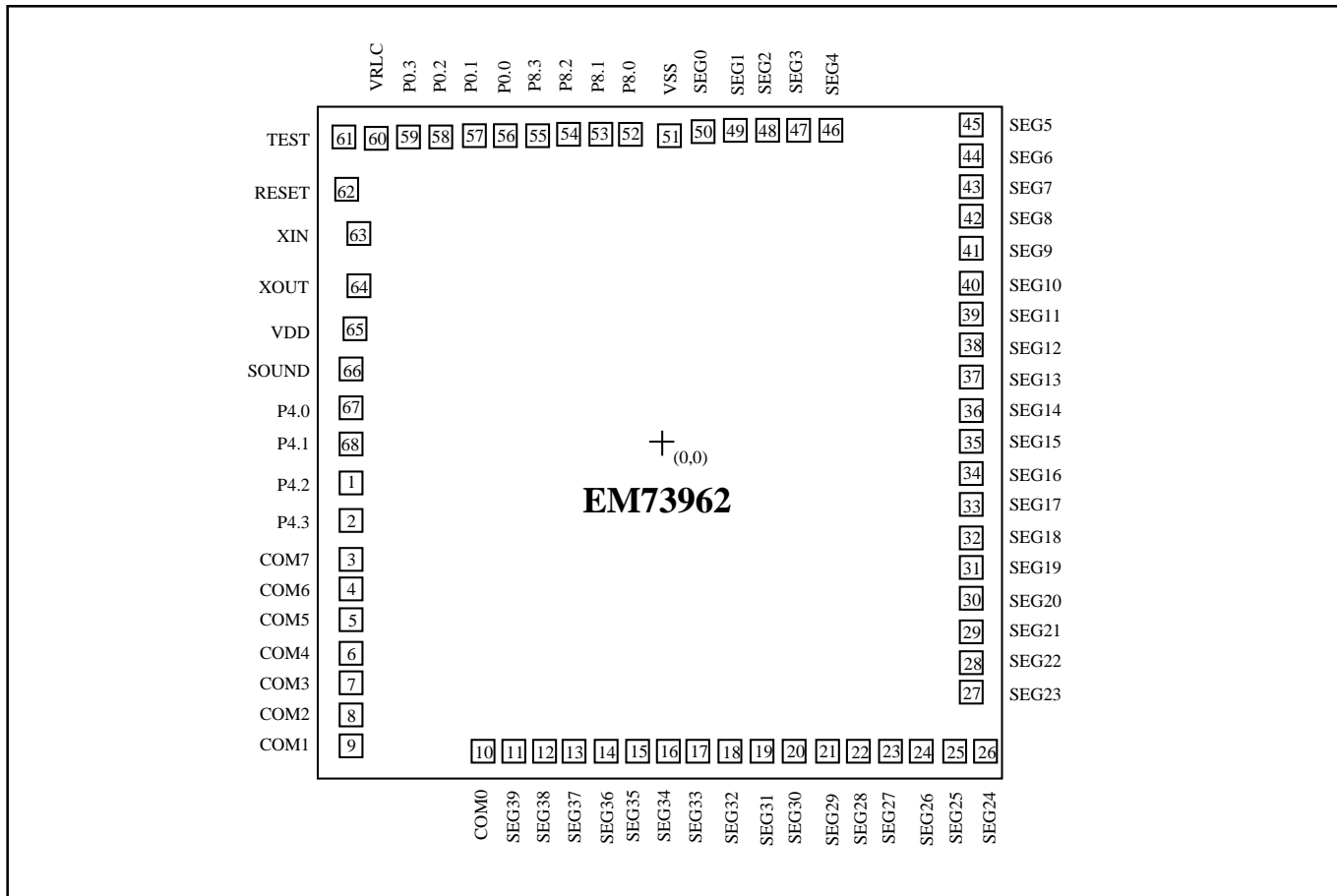

Chip Size : 2870 x 2830 μm

Pad No.	Symbol	X	Y
1	P4.2	-1267.3	-147.3
2	P4.3	-1267.3	-301.4
3	COM7	-1269.4	-448.7
4	COM6	-1269.4	-576.8
5	COM5	-1269.4	-704.9
6	COM4	-1269.4	-833.0
7	COM3	-1269.4	-961.1
8	COM2	-1269.4	-1089.2
9	COM1	-1269.4	-1217.3
10	COM0	-773.7	-1249.4
11	SEG39	-645.6	-1249.4
12	SEG38	-517.5	-1249.4
13	SEG37	-389.4	-1249.4
14	SEG36	-261.3	-1249.4
15	SEG35	-133.2	-1249.4
16	SEG34	-5.1	-1249.4
17	SEG33	123.0	-1249.4
18	SEG32	251.1	-1249.4

* This specification are subject to be changed without notice.



Pad No.	Symbol	X	Y
19	SEG31	379.2	-1249.4
20	SEG30	507.3	-1249.4
21	SEG29	635.4	-1249.4
22	SEG28	763.5	-1249.4
23	SEG27	891.6	-1249.4
24	SEG26	1019.7	-1249.4
25	SEG25	1147.8	-1249.4
26	SEG24	1275.9	-1249.4
27	SEG23	1266.8	-1041.0
28	SEG22	1266.8	-912.9
29	SEG21	1266.8	-784.8
30	SEG20	1266.8	-656.7
31	SEG19	1266.8	-528.6
32	SEG18	1266.8	-400.5
33	SEG17	1266.8	-272.4
34	SEG16	1266.8	-144.3
35	SEG15	1266.8	-16.2
36	SEG14	1266.8	111.9
37	SEG13	1266.8	240.0
38	SEG12	1266.8	368.1
39	SEG11	1266.8	496.2
40	SEG10	1266.8	624.3
41	SEG9	1266.8	752.4
42	SEG8	1266.8	880.5
43	SEG7	1266.8	1008.6
44	SEG6	1266.8	1136.7
45	SEG5	1266.8	1264.8
46	SEG4	708.6	1250.8
47	SEG3	580.5	1250.8
48	SEG2	452.4	1250.8
49	SEG1	324.3	1250.8
50	SEG0	196.2	1250.8
51	VSS	58.6	1235.8
52	P8.0	-101.3	1250.8
53	P8.1	-229.6	1250.8
54	P8.2	-363.0	1250.8
55	P8.3	-491.2	1250.8
56	P0.0	-624.6	1250.8
57	P0.1	-752.9	1250.8
58	P0.2	-886.3	1250.8
59	P0.3	-1014.5	1250.8
60	VRLC	-1145.3	1250.8
61	TEST	-1276.1	1250.8
62	RESET	-1269.6	1032.4
63	XIN	-1225.5	854.4
64	XOUT	-1224.6	643.4

* This specification are subject to be changed without notice.



Pad No.	Symbol	X	Y
65	VDD	-1249.3	472.4
66	SOUND	-1268.0	311.8
67	P4.0	-1267.3	160.7
68	P4.1	-1267.3	6.7

INSTRUCTION TABLE

(1) Data Transfer

Mnemonic	Object code (binary)	Operation description	Byte	Cycle	Flag		
					C	Z	S
LDA x	0110 1010 xxxx xxxx	Acc←RAM[x]	2	2	-	Z	1
LDAM	0101 1010	Acc←RAM[HL]	1	1	-	Z	1
LDAX	0110 0101	Acc←ROM[DP] _L	1	2	-	Z	1
LDAXI	0110 0111	Acc←ROM[DP] _H ,DP+1	1	2	-	Z	1
LDH #k	1001 kkkk	HR←k	1	1	-	-	1
LDHL x	0100 1110 xxxx xx00	LR←RAM[x],HR←RAM[x+1]	2	2	-	-	1
LDIA #k	1101 kkkk	Acc←k	1	1	-	Z	1
LDL #k	1000 kkkk	LR←k	1	1	-	-	1
STA x	0110 1001 xxxx xxxx	RAM[x]←Acc	2	2	-	-	1
STAM	0101 1001	RAM[HL]←Acc	1	1	-	-	1
STAMD	0111 1101	RAM[HL]←Acc, LR-1	1	1	-	Z	C
STAMI	0111 1111	RAM[HL]←Acc, LR+1	1	1	-	Z	C'
STD #k,y	0100 1000 kkkk yyyy	RAM[y]←k	2	2	-	-	1
STDMI #k	1010 kkkk	RAM[HL]←k, LR+1	1	1	-	Z	C'
THA	0111 0110	Acc←HR	1	1	-	Z	1
TLA	0111 0100	Acc←LR	1	1	-	Z	1

(2) Rotate

Mnemonic	Object code (binary)	Operation description	Byte	Cycle	Flag		
					C	Z	S
RLCA	0101 0000	←CF←Acc←1	1	1	C	Z	C'
RRCA	0101 0001	1→CF→Acc→	1	1	C	Z	C'

(3) Arithmetic operation

Mnemonic	Object code (binary)	Operation description	Byte	Cycle	Flag		
					C	Z	S
ADCAM	0111 0000	Acc←Acc + RAM[HL] + CF	1	1	C	Z	C'
ADD #k,y	0100 1001 kkkk yyyy	RAM[y]←RAM[y] +k	2	2	-	Z	C'
ADDA #k	0110 1110 0101 kkkk	Acc←Acc+k	2	2	-	Z	C'
ADDAM	0111 0001	Acc←Acc + RAM[HL]	1	1	-	Z	C'
ADDH #k	0110 1110 1001 kkkk	HR←HR+k	2	2	-	Z	C'
ADDL #k	0110 1110 0001 kkkk	LR←LR+k	2	2	-	Z	C'
ADDM #k	0110 1110 1101 kkkk	RAM[HL]←RAM[HL] +k	2	2	-	Z	C'
DECA	0101 1100	Acc←Acc-1	1	1	-	Z	C
DECL	0111 1100	LR←LR-1	1	1	-	Z	C
DECM	0101 1101	RAM[HL]←RAM[HL] -1	1	1	-	Z	C
INCA	0101 1110	Acc←Acc + 1	1	1	-	Z	C'

INCL	0111 1110	LR←LR + 1	1	1	-	Z	C'
INCM	0101 1111	RAM[HL]←RAM[HL]+1	1	1	-	Z	C'
SUBA #k	0110 1110 0111 kkkk	Acc←k-Acc	2	2	-	Z	C
SBCAM	0111 0010	Acc←RAM[HL] - Acc - CF'	1	1	C	Z	C
SUBM #k	0110 1110 1111 kkkk	RAM[HL]←k - RAM[HL]	2	2	-	Z	C

(4) Logical operation

Mnemonic	Object code (binary)	Operation description	Byte	Cycle	Flag		
					C	Z	S
ANDA #k	0110 1110 0110 kkkk	Acc←Acc&k	2	2	-	Z	Z'
ANDAM	0111 1011	Acc←Acc & RAM[HL]	1	1	-	Z	Z'
ANDM #k	0110 1110 1110 kkkk	RAM[HL]←RAM[HL]&k	2	2	-	Z	Z'
ORA #k	0110 1110 0100 kkkk	Acc←Acc k	2	2	-	Z	Z'
ORAM	0111 1000	Acc ←Acc RAM[HL]	1	1	-	Z	Z'
ORM #k	0110 1110 1100 kkkk	RAM[HL]←RAM[HL] k	2	2	-	Z	Z'
XORAM	0111 1001	Acc←Acc^RAM[HL]	1	1	-	Z	Z'

(5) Exchange

Mnemonic	Object code (binary)	Operation description	Byte	Cycle	Flag		
					C	Z	S
EXA x	0110 1000 xxxx xxxx	Acc↔RAM[x]	2	2	-	Z	1
EXAH	0110 0110	Acc↔HR	1	2	-	Z	1
EXAL	0110 0100	Acc↔LR	1	2	-	Z	1
EXAM	0101 1000	Acc↔RAM[HL]	1	1	-	Z	1
EXHL x	0100 1100 xxxx xx00	LR↔RAM[x], HR↔RAM[x+1]	2	2	-	-	1

(6) Branch

Mnemonic	Object code (binary)	Operation description	Byte	Cycle	Flag		
					C	Z	S
SBR a	00aa aaaa	If SF=1 then PC←PC ₁₂₋₆ .a ₅₋₀ else null	1	1	-	-	1
LBR a	1100 aaaa aaaa aaaa	If SF= 1 then PC←a else null	2	2	-	-	1
SLBR a	0101 0101 1100 aaaa aaaa aaaa (a:1000~1FFFh) 0101 0111 1100 aaaa aaaa aaaa (a:0000~0FFFh)	If SF=1 then PC←a else null	3	3	-	-	1

(7) Compare

Mnemonic	Object code (binary)	Operation description	Byte	Cycle	Flag		
					C	Z	S
CMP #k,y	0100 1011 kkkk yyyy	k-RAM[y]	2	2	C	Z	Z'
CMPA x	0110 1011 xxxx xxxx	RAM[x]-Acc	2	2	C	Z	Z'

Mnemonic	Object code (binary)	Operation description	Byte	Cycle	Flag		
					C	Z	S
CMPAM	0111 0011	RAM[HL] - Acc	1	1	C	Z	Z'
CMPH #k	0110 1110 1011 kkkk	k - HR	2	2	-	Z	C
CMPIA #k	1011 kkkk	k - Acc	1	1	C	Z	Z'
CMPL #k	0110 1110 0011 kkkk	k-LR	2	2	-	Z	C

(8) Bit manipulation

Mnemonic	Object code (binary)	Operation description	Byte	Cycle	Flag		
					C	Z	S
CLM b	1111 00bb	RAM[HL] _b ← 0	1	1	-	-	1
CLP p,b	0110 1101 11bb pppp	PORT[p] _b ← 0	2	2	-	-	1
CLPL	0110 0000	PORT[LR ₃₋₂ +4]LR ₁₋₀ ← 0	1	2	-	-	1
CLR y,b	0110 1100 11bb yyyy	RAM[y] _b ← 0	2	2	-	-	1
SEM b	1111 01bb	RAM[HL] _b ← 1	1	1	-	-	1
SEP p,b	0110 1101 01bb pppp	PORT[p] _b ← 1	2	2	-	-	1
SEPL	0110 0010	PORT[LR ₃₋₂ +4]LR ₁₋₀ ← 1	1	2	-	-	1
SET y,b	0110 1100 01bb yyyy	RAM[y] _b ← 1	2	2	-	-	1
TF y,b	0110 1100 00bb yyyy	SF ← RAM[y] _b '	2	2	-	-	*
TFA b	1111 10bb	SF ← Acc _b '	1	1	-	-	*
TFM b	1111 11bb	SF ← RAM[HL] _b '	1	1	-	-	*
TFP p,b	0110 1101 00bb pppp	SF ← PORT[p] _b '	2	2	-	-	*
TFPL	0110 0001	SF ← PORT[LR ₃₋₂ +4]LR ₁₋₀ '	1	2	-	-	*
TT y,b	0110 1100 10bb yyyy	SF ← RAM[y] _b	2	2	-	-	*
TTP p,b	0110 1101 10bb pppp	SF ← PORT[p] _b	2	2	-	-	*

(9) Subroutine

Mnemonic	Object code (binary)	Operation description	Byte	Cycle	Flag		
					C	Z	S
LCALL a	0100 0aaa aaaa aaaa	STACK[SP] ← PC, SP ← SP - 1, PC ← a	2	2	-	-	-
SCALL a	1110 nnnn	STACK[SP] ← PC, SP ← SP - 1, PC ← a, a = 8n + 6 (n = 1~15), 0086h (n = 0)	1	2	-	-	-
RET	0100 1111	SP ← SP + 1, PC ← STACK[SP]	1	2	-	-	-

(10) Input/output

Mnemonic	Object code (binary)	Operation description	Byte	Cycle	Flag		
					C	Z	S
INA p	0110 1111 0100 pppp	Acc ← PORT[p]	2	2	-	Z	Z'
INM p	0110 1111 1100 pppp	RAM[HL] ← PORT[p]	2	2	-	-	Z'
OUT #k,p	0100 1010 kkkk pppp	PORT[p] ← k	2	2	-	-	1
OUTA p	0110 1111 000p pppp	PORT[p] ← Acc	2	2	-	-	1
OUTM p	0110 1111 100p pppp	PORT[p] ← RAM[HL]	2	2	-	-	1

(11) Flag manipulation

Mnemonic	Object code (binary)	Operation description	Byte	Cycle	Flag		
					C	Z	S
TFCFC	0101 0011	SF←CF', CF←0	1	1	0	-	*
TTCFS	0101 0010	SF←CF, CF←1	1	1	1	-	*
TZS	0101 1011	SF←ZF	1	1	-	-	*

(12) Interrupt control

Mnemonic	Object code (binary)	Operation description	Byte	Cycle	Flag		
					C	Z	S
CIL r	0110 0011 11rr rrrr	IL←IL & r	2	2	-	-	1
DICIL r	0110 0011 10rr rrrr	EIF←0,IL←IL&r	2	2	-	-	1
EICIL r	0110 0011 01rr rrrr	EIF←1,IL←IL&r	2	2	-	-	1
EXAE	0111 0101	MASK↔Acc	1	1	-	-	1
RTI	0100 1101	SP←SP+1,FLAG.PC ←STACK[SP],EIF ←1	1	2	*	*	*

(13) CPU control

Mnemonic	Object code (binary)	Operation description	Byte	Cycle	Flag		
					C	Z	S
NOP	0101 0110	no operation	1	1	-	-	-

(14) Timer/Counter & Data pointer & Stack pointer control

Mnemonic	Object code (binary)	Operation description	Byte	Cycle	Flag		
					C	Z	S
LDADPL	0110 1010 1111 1100	Acc←[DP] _L	2	2	-	Z	1
LDADPM	0110 1010 1111 1101	Acc←[DP] _M	2	2	-	Z	1
LDADPH	0110 1010 1111 1110	Acc←[DP] _H	2	2	-	Z	1
LDASP	0110 1010 1111 1111	Acc←SP	2	2	-	Z	1
LDATAL	0110 1010 1111 0100	Acc←[TA] _L	2	2	-	Z	1
LDATAM	0110 1010 1111 0101	Acc←[TA] _M	2	2	-	Z	1
LDATAH	0110 1010 1111 0110	Acc←[TA] _H	2	2	-	Z	1
LDATBL	0110 1010 1111 1000	Acc←[TB] _L	2	2	-	Z	1
LDATBM	0110 1010 1111 1001	Acc←[TB] _M	2	2	-	Z	1
LDATBH	0110 1010 1111 1010	Acc←[TB] _H	2	2	-	Z	1
STADPL	0110 1001 1111 1100	[DP] _L ←Acc	2	2	-	-	1
STADPM	0110 1001 1111 1101	[DP] _M ←Acc	2	2	-	-	1
STADPH	0110 1001 1111 1110	[DP] _H ←Acc	2	2	-	-	1
STASP	0110 1001 1111 1111	SP←Acc	2	2	-	-	1
STATAL	0110 1001 1111 0100	[TA] _L ←Acc	2	2	-	-	1
STATAM	0110 1001 1111 0101	[TA] _M ←Acc	2	2	-	-	1
STATAH	0110 1001 1111 0110	[TA] _H ←Acc	2	2	-	-	1
STATBL	0110 1001 1111 1000	[TB] _L ←Acc	2	2	-	-	1
STATBM	0110 1001 1111 1001	[TB] _M ←Acc	2	2	-	-	1
STATBH	0110 1001 1111 1010	[TB] _H ←Acc	2	2	-	-	1

* This specification are subject to be changed without notice.

**** SYMBOL DESCRIPTION

Symbol	Description	Symbol	Description
HR	H register	LR	L register
PC	Program counter	DP	Data pointer
SP	Stack pointer	STACK[SP]	Stack specified by SP
A _{CC}	Accumulator	FLAG	All flags
CF	Carry flag	ZF	Zero flag
SF	Status flag	EI	Enable interrupt register
IL	Interrupt latch	MASK	Interrupt mask
PORT[p]	Port (address : p)	TA	Timer/counter A
TB	Timer/counter B	RAM[HL]	Data memory (address : HL)
RAM[x]	Data memory (address : x)	ROM[DP] _L	Low 4-bit of program memory
ROM[DP] _H	High 4-bit of program memory	[DP] _L	Low 4-bit of data pointer register
[DP] _M	Middle 4-bit of data pointer register	[DP] _H	High 4-bit of data pointer register
[TA] _L ([TB] _L)	Low 4-bit of timer/counter A (timer/counter B) register	[TA] _M ([TB] _M)	Middle 4-bit of timer/counter A (timer/counter B) register
[TA] _H ([TB] _H)	High 4-bit of timer/counter A (timer/counter B) register	LR ₁₋₀	Contents of bit assigned by bit 1 to 0 of LR
LR ₃₋₂	Bit 3 to 2 of LR	a ₅₋₀	Bit 5 to 0 of destination address for branch instruction
PC ₁₂₋₆	Bit 12 to 6 of program counter	←	Transfer
↔	Exchange	+	Addition
-	Substraction	&	Logic AND
	Logic OR	^	Logic XOR
!	Inverse operation	.	Concatenation
#k	4-bit immediate data	x	8-bit RAM address
y	4-bit zero-page address	p	4-bit or 5-bit port address
b	Bit address	r	6-bit interrupt latch