

CFPS-72, -73 Semtech Reference - Stratum 4

ISSUE 5; 19 OCTOBER 2004

Delivery Options

- Common frequencies are available from stock. Please see stock list or contact sales office

Output Compatibility

- Tri-state HCMOS/TTL (5.0V) (CFPS-72), Load 15pF max
- Tri-state HCMOS (3.3V) (CFPS-73), Load 15pF max

Package Outline

- 7.0 x 5.0mm SMD Ceramic Package.
Available over 0 to 70°C (CFPS-72, -73) or
-40 to 85°C (CFPS-72I, -73I)

Standard Frequency Stabilities

- ± 20 ppm, ± 25 ppm, ± 50 ppm, ± 100 ppm (inclusive of supply voltage & output load variations over the operating temperature range)

Operating Temperature Range

- 0 to 70°C (CFPS-72, -73)
- 40 to 85°C (CFPS-72I, -73I)

Storage Temperature Range

- 55 to 125°C

Tri-state Operation

- Logic '1' to pad 1 enables oscillator output, 2.2V min
- Logic '0' to pad 1 disables oscillator output; when disabled the oscillator output goes to the high impedance state, 0.8V max
- No connection to pad 1 enables oscillator output

Solder Conditions

- For typical soldering conditions, please see the relevant pages in Applications Notes

Marking

- Model Number (+ Operating Temperature Code; if applicable)
- Frequency Stability Code
- Frequency

Minimum Order Information Required

- Frequency + Model Number + Operating Temperature Code (if applicable) + Frequency Stability
- Please refer to our programmable oscillator chapter for fast make products

Outline in mm

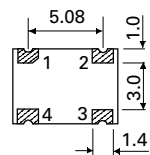
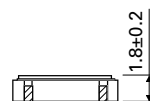
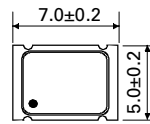

Pad Connections

- N/C or Enable/Disable
- GND
- Output
- +Vs

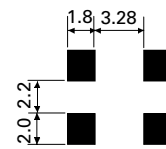

Solder pad layout

Output Waveform

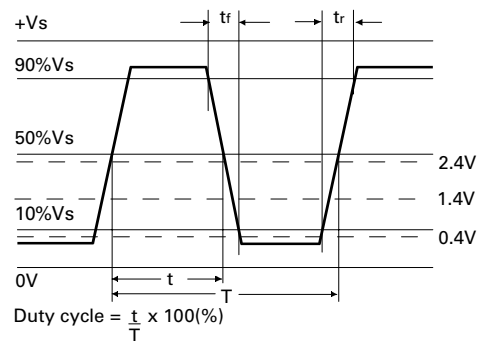

Electrical Specification - maximum limiting values when measured in HCMOS test circuit

Frequency Range	Frequency Stability	Supply Voltage	Supply Current	Rise Time(tr)	Fall Time (tf)	Duty Cycle	Model Number
1.25 to 35.0MHz	±20ppm, ±25ppm, ±50ppm, ±100ppm	3.3V	15mA	6ns	6ns	40/60%	CFPS-73, CFPS-73I
>35.0 to 70.0MHz			30mA	6ns	6ns		
>70.0 to 106.25MHz			40mA	6ns	6ns		
>106.25 to 120.0MHz			40mA	6ns	6ns		
>120.0 to 125.0MHz			40mA	6ns	6ns		
>125.0 to 160MHz			40mA	6ns	6ns		
1.25 to 20.0MHz	±25ppm, ±50ppm ±100ppm	5.0V	20mA	6ns	6ns		CFPS-72, CFPS-72I
>20.0 to 35.0MHz			30mA	6ns	6ns		
>35.0 to 70.0MHz			50mA	6ns	6ns		
>70.0 TO 100.0MHz			70mA	6ns	6ns		
>100.0 to 125.0MHz			70mA	6ns	6ns		
>125.0 to 160.0MHz			70mA	6ns	6ns		

Ordering Example
 Frequency 24.0MHz CFPS-73I C
 Model No _____
 Operating Temperature Code: I = -40 to 85°C; Not applicable for 0 to 70°C
 Frequency Stability: A = ±25ppm; B = ±50ppm; C = ±100ppm; G = ±20ppm

Test Circuit - HCMOS

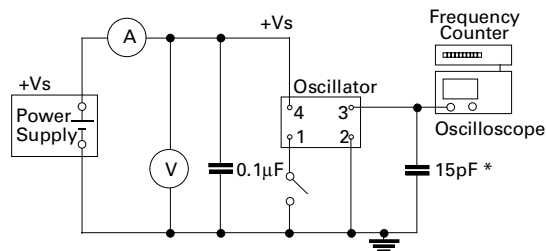

* Inclusive of jigging & equipment capacitance

Test Circuit - TTL

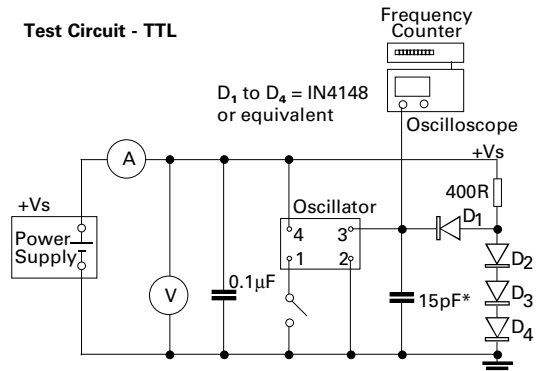

*Inclusive of jigging & equipment capacitance
 Note: CFPS-72, 72I only

Outline in mm - Tape

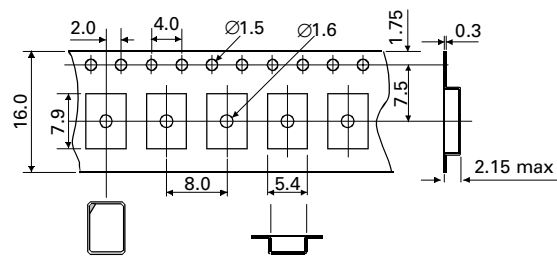

Outline in mm - Reel

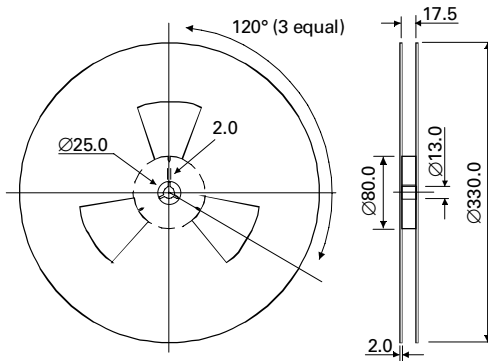

SEMTECH
 APPROVED PRODUCTS