

DSP56603

Advance Information 16-BIT DIGITAL SIGNAL PROCESSOR

The DSP56603 is designed specifically for low-power digital cellular subscriber applications and can perform a wide variety of fixed-point digital signal processing algorithms. The DSP56603 is a member of the DSP56600 core family of 16-bit programmable CMOS Digital Signal Processors (DSPs). The DSP56600 core can execute one instruction per clock cycle. This 60-MHz chip is optimized for processing-intensive, yet cost-effective, low power consumption digital mobile communications applications. Because the DSP56603 provides on-chip Program and data RAM, as well as the ability to switch sections of this memory between program and data memory, it is also suitable for use as a development platform. **Figure 1** provides a block diagram of the DSP56603, showing the core structures and the expansion areas. The DSP56600 core includes the Data Arithmetic and Logic Unit (ALU), Address Generation Unit (AGU), Program Controller, Program Patch Detector, Bus Interface Unit, On-Chip Emulation (OnCE™) module, JTAG port, and a Phase Lock Loop (PLL)-based clock generator. The expansion areas provide the switchable program and data memories, as well as a versatile set of on-chip peripherals and external ports.

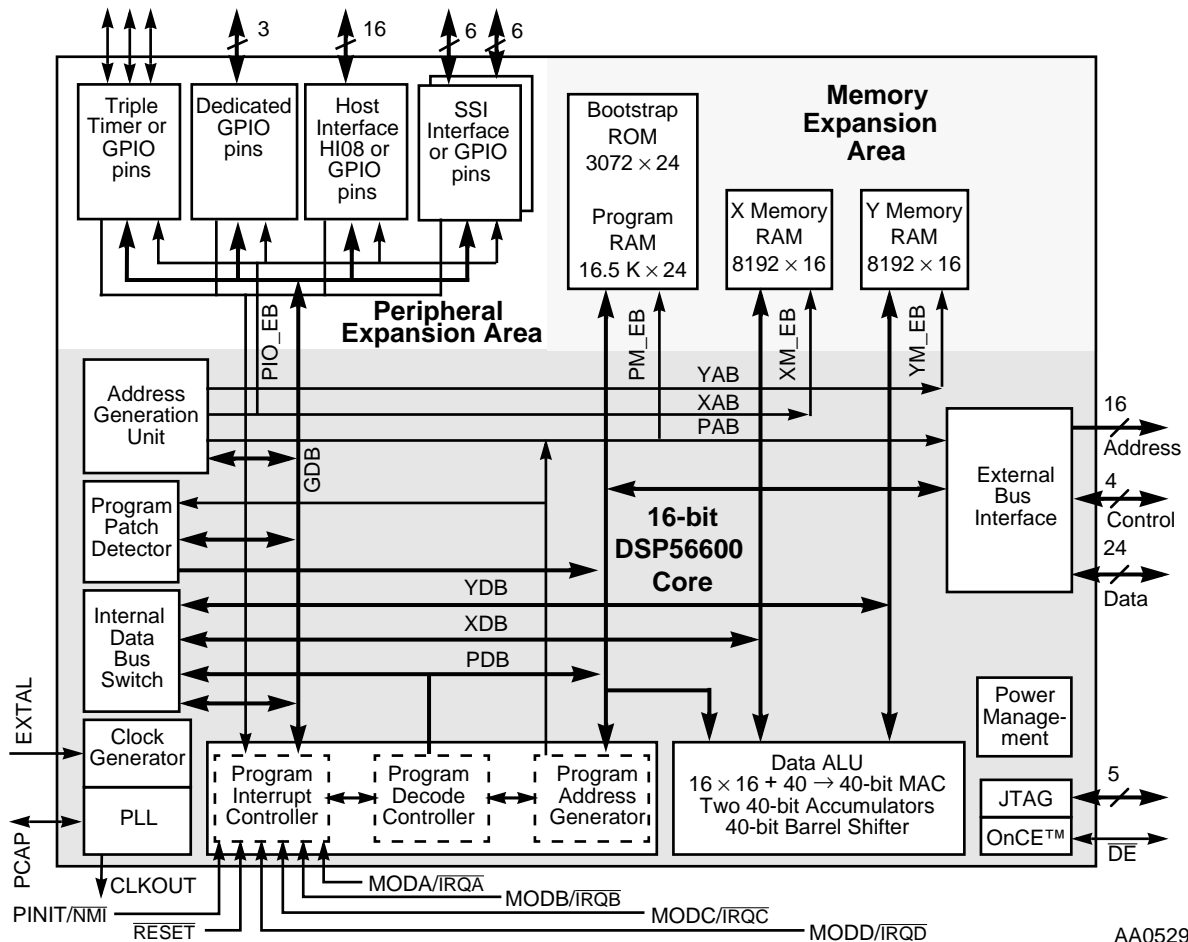

Figure 1 DSP56603 Block Diagram

This document contains information on a new product. Specifications and information herein are subject to change without notice.

TABLE OF CONTENTS

SECTION 1	SIGNAL/CONNECTION DESCRIPTIONS	1-1
SECTION 2	SPECIFICATIONS	2-1
SECTION 3	PACKAGING	3-1
SECTION 4	DESIGN CONSIDERATIONS	4-1
SECTION 5	ORDERING INFORMATION	5-1
APPENDIX A	POWER CONSUMPTION BENCHMARK	A-1

DATA SHEET CONVENTIONS

This data sheet uses the following conventions:

OVERBAR This is used to indicate a signal that is active when pulled low. For example, the RESET pin is active when low.

“asserted” A high true (active high) signal is high or a low true (active low) signal is low.

“deasserted” A high true (active high) signal is low or a low true (active low) signal is high.

Examples:	Signal/Symbol	Logic State	Signal State	Voltage ¹
	$\overline{\text{PIN}}$	True	Asserted	$V_{\text{IL}}/V_{\text{OL}}$
	$\overline{\text{PIN}}$	False	Deasserted	$V_{\text{IH}}/V_{\text{OH}}$
	PIN	True	Asserted	$V_{\text{IH}}/V_{\text{OH}}$
	PIN	False	Deasserted	$V_{\text{IL}}/V_{\text{OL}}$

Note: 1. Values for V_{IL} , V_{OL} , V_{IH} , and V_{OH} are defined by individual product specifications.

DSP56603 FEATURES

Digital Signal Processing Core

- High-performance DSP56600 core
- Up to 60 Million Instructions Per Second (MIPS) at 2.7–3.3 V
- Fully pipelined 16×16 -bit parallel Multiply-Accumulator (MAC)
- Two 40-bit accumulators including extension bits
- 40-bit parallel barrel shifter
- Highly parallel instruction set with unique DSP addressing modes
- Code-compatible with the DSP56300 core
- Position-independent code support
- User-selectable stack extension
- Nested hardware DO loops
- Fast auto-return interrupts
- On-chip support for software patching and enhancements
- On-chip Phase Lock Loop (PLL) circuit
- Real-time trace capability via external address bus
- On-Chip Emulator (OnCE) module and JTAG port

Memory

- Switch Mode memory allows reconfiguring program, X-data, and Y-data RAM sizes
 - Switch Mode off
 - $16.5 \text{ K} \times 24$ -bit Program RAM
 - $8 \text{ K} \times 16$ -bit X-data RAM
 - $8 \text{ K} \times 16$ -bit Y-data RAM
 - Switch Mode on
 - $11.5 \text{ K} \times 24$ -bit Program RAM
 - $10.5 \text{ K} \times 16$ -bit X-data RAM
 - $10.5 \text{ K} \times 16$ -bit Y-data RAM
- $3 \text{ K} \times 24$ -bit bootstrap ROM

Data Sheet Conventions

- Off-chip expansion for both program fetch and program data transfers
- No additional logic needed for interface to external SRAM memories

Peripheral Circuits

- Three dedicated General Purpose Input/Output (GPIO) pins and as many as thirty-one additional GPIO pins (user-selectable as peripherals or GPIO pins)
- Host Interface (HI08) support: one 8-bit parallel port (or as many as sixteen additional GPIO pins)
 - Direct interface to Motorola HC11, Hitachi H8, 8051 family, Thomson P6 family
 - Minimal logic interface to standard ISA bus, Motorola 68K family, and Intel x86 microprocessor family.
- Synchronous Serial Interface (SSI) support: two 6-pin ports (or twelve additional GPIO pins)
 - Supports serial devices with one or more industry-standard codecs, other DSPs, microprocessors, and Motorola SPI-compliant peripherals
 - Independent transmitter and receiver sections and a common SSI clock generator
 - Network mode using frame sync and up to 32 time slots
 - 8-bit, 12-bit, and 16-bit data word lengths
- Three programmable timers (or as many as three additional GPIO pins)
- Three external interrupt/mode control lines
- One external reset pin for hardware reset

Energy Efficient Design

- Very low power CMOS design
 - Operating voltage range: 1.8 V to 3.3 V
 - < 0.85 mA/MIPS at 2.7 V
 - < 0.55 mA/MIPS at 1.8 V
- Low power Wait for interrupt standby mode, and ultra low power Stop standby mode
- Fully static, HCMOS design for operating frequencies from 60 MHz down to DC
- Special power management circuitry

PRODUCT DOCUMENTATION

The three documents listed in **Table 1** are required for a complete description of the DSP56603 and are necessary to design properly with the part. Documentation is available from a local Motorola distributor, a Motorola semiconductor sales office, a Motorola Literature Distribution Center, or through the Motorola DSP home page on the Internet (the source for the latest information).

Table 1 DSP56602 Chip Documentation

Topic	Description	Order Number
DSP56600 Family Manual	Detailed description of the 56600-family architecture, and 16-bit DSP core processor and the instruction set	DSP56600FM/AD
DSP56603 User's Manual	Detailed description of memory, peripherals, and interfaces of the DSP56603	DSP56603UM/AD
DSP56603 Technical Data	Electrical and timing specifications, pin descriptions, and package descriptions	DSP56603/D

FOR THE LATEST INFORMATION

Refer to the back cover of this document for:

- Motorola contact addresses
- Motorola Mfax™ service
- Motorola DSP Internet address
- Motorola DSP Helpline

The Mfax service and the DSP Internet connection maintain the most current specifications, documents, and drawings. These two services are available on demand 24 hours a day.

SECTION 1

SIGNAL/CONNECTION DESCRIPTIONS

INTRODUCTION

The input and output signals of the DSP56603 are organized into functional groups, as shown in **Table 1-1** and as illustrated in **Figure 1-1**. In **Table 1-2** through **Table 1-12**, each table row describes the signal or signals present on a pin.

The DSP56603 is operated from a 3 V supply; however, some of the inputs can tolerate 5 V. A special notice for this feature is added to the signal descriptions of those inputs.

Table 1-1 Functional Group Signal Allocations

Functional Group		Number of Signals	Detailed Description
Power (V_{CC})		19	Table 1-2
Ground (GND)		19	Table 1-3
PLL and Clock Signals		5	Table 1-4
Interrupt and Mode Control		5	Table 1-5
External Memory Port (also referred to as Port A)	Address Bus	16	Table 1-6
	Data Bus	24	
	Bus Control	4	
Host Interface (HI08)	Port B (GPIO)	16	Table 1-7
Synchronous Serial Interface 0 (SSI0)	Port C (GPIO)	6	Table 1-8
Synchronous Serial Interface 1 (SSI1)	Port D (GPIO)	6	Table 1-9
General Purpose Input/Output (GPIO)		3	Table 1-10
Triple Timer		3	Table 1-11
JTAG/On-Chip Emulation (OnCE) Module		6	Table 1-12

Introduction

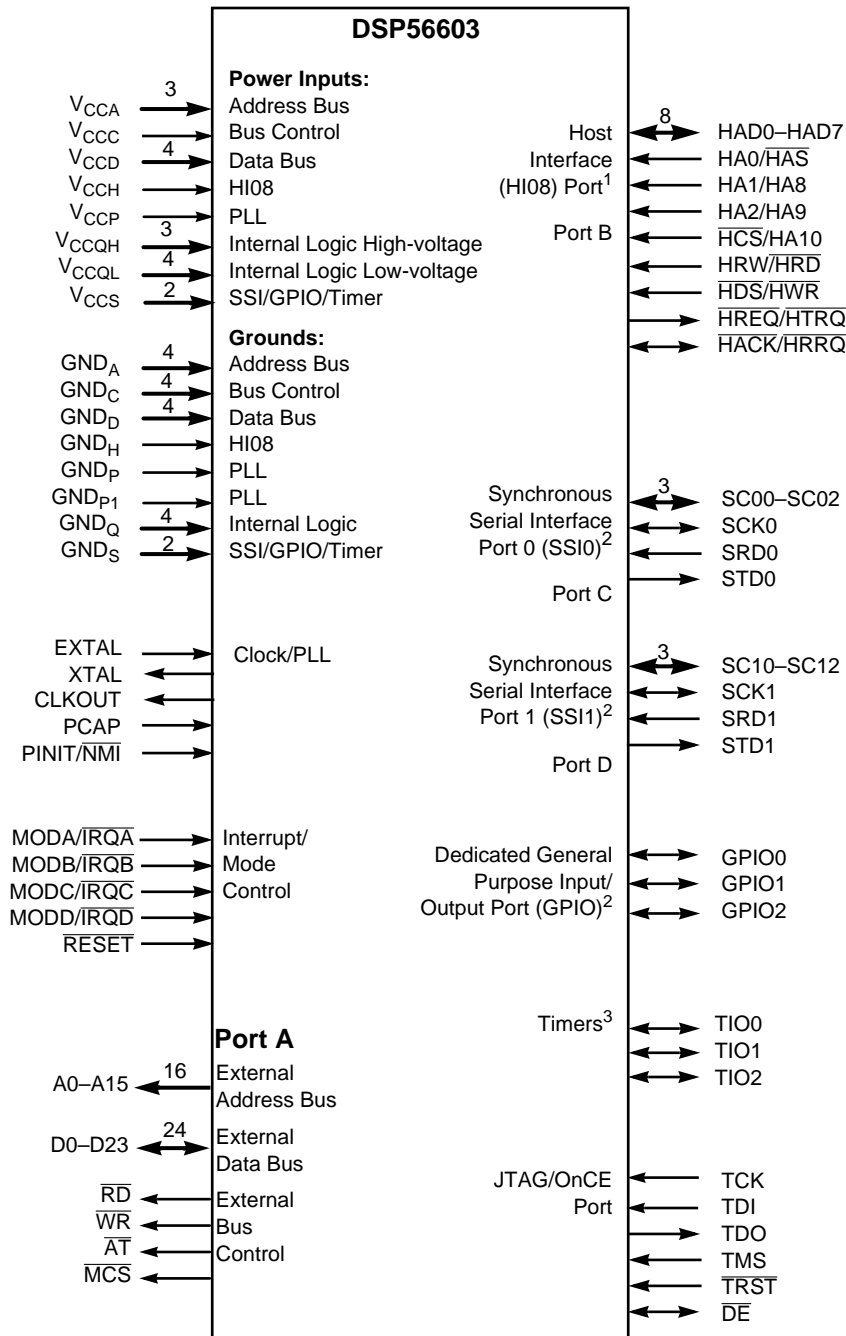

AA0355

- Note:
1. The HI08 port supports a non-multiplexed or a multiplexed bus, single or double Data Strobe (DS), and single or double Host Request (HR) configurations. Since each these modes is configured independently, any combination of these modes is possible. The HI08 signals can also be configured alternately as GPIO signals (PB0–PB15).
 2. The SSI0 and SSI1 signals can be configured alternately as Port C GPIO signals (PC0–PC5) and Port D GPIO signals (PD0–PD5), respectively.
 3. TIO0–TIO2 can be configured alternately as GPIO signals.

Figure 1-1 DSP56603 Signals Identified by Functional Group

POWER

Table 1-2 Power Inputs

Signal Name (number of pins)	Signal Description
V_{CCA} (3)	Address Bus Power — V_{CCA} is an isolated power for sections of address bus I/O drivers, and must be tied externally to all other chip power inputs, except for the V_{CCQL} input. The user must provide adequate external decoupling capacitors.
V_{CCC} (1)	Bus Control Power — V_{CCC} is an isolated power for the bus control I/O drivers, and must be tied to all other chip power inputs externally, except for the V_{CCQL} input. The user must provide adequate external decoupling capacitors.
V_{CCD} (4)	Data Bus Power — V_{CCD} is an isolated power for sections of data bus I/O drivers, and must be tied to all other chip power inputs externally, except for the V_{CCQL} input. The user must provide adequate external decoupling capacitors.
V_{CCH} (1)	Host Power — V_{CCH} is an isolated power for the HI08 logic, and must be tied to all other chip power inputs externally, except for the V_{CCQL} input. The user must provide adequate external decoupling capacitors.
V_{CCP} (1)	PLL Power — V_{CCP} is V_{CC} dedicated for Phase Lock Loop (PLL) use. The voltage should be well-regulated and the input should be provided with an extremely low impedance path to the V_{CC} power rail.
V_{CCQH} (3)	Quiet Power High-voltage — V_{CCQH} is an isolated power for the CPU logic, and must be tied to all other chip power inputs externally, except for the V_{CCQL} input. The user must provide adequate external decoupling capacitors. The voltage supplied to these inputs should equal the voltage supplied to I/O power inputs V_{CCA} , V_{CCC} , V_{CCD} , V_{CCH} , and V_{CCS} .
V_{CCQL} (4)	Quiet Power Low-voltage — V_{CCQL} is an isolated power for the CPU logic, and should not be tied to the other chip power inputs. The user must provide adequate external decoupling capacitors.
V_{CCS} (2)	SSIs, GPIO and Timers Power — V_{CCS} is a isolated power for the SSIs, GPIO, and Timers logic, and must be tied to all other chip power inputs externally, except for the V_{CCQL} input. The user must provide adequate external decoupling capacitors.

GROUND

Table 1-3 Grounds

Signal Name (number of pins)	Signal Description
GND _A (4)	Address Bus Ground —GND _A is an isolated ground for sections of address bus I/O drivers, and must be tied externally to all other chip ground connections. The user must provide adequate external decoupling capacitors.
GND _C (2)	Bus Control Ground —GND _C is an isolated ground for the bus control I/O drivers, and must be tied externally to all other chip ground connections. The user must provide adequate external decoupling capacitors.
GND _D (4)	Data Bus Ground —GND _D is an isolated ground for sections of the data bus I/O drivers, and must be tied externally to all other chip ground connections. The user must provide adequate external decoupling capacitors.
GND _H (1)	Host Ground —GND _H is an isolated ground for the HI08 I/O drivers, and must be tied externally to all other chip ground connections. The user must provide adequate external decoupling capacitors.
GND _P (1)	PLL Ground —GND _P is ground dedicated for PLL use, and should be provided with an extremely low impedance path to ground. V _{CCP} should be bypassed to GND _P with a 0.1 μF capacitor located as close as possible to the chip package.
GND _{P1} (1)	PLL Ground 1 —GND _{P1} is ground dedicated for PLL use, and should be provided with an extremely low impedance path to ground.
GND _Q (4)	Quiet Ground —GND _Q is an isolated ground for the CPU logic, and must be tied externally to all other chip ground connections. The user must provide adequate external decoupling capacitors.
GND _S (2)	SSIs, GPIO, and Timers Ground —GND _S is an isolated ground for the SSIs, GPIO, and Timers logic, and must be tied externally to all other chip ground connections. The user must provide adequate external decoupling capacitors.

CLOCK AND PHASE LOCK LOOP

Table 1-4 Clock and PLL Signals

Signal Name	Signal Type	State During Reset	Signal Description
EXTAL	Input	Input	External Clock/Crystal Input —EXTAL interfaces the internal crystal oscillator input to an external crystal or an external clock.
XTAL	Output	Chip-driven	Crystal Output —XTAL connects the internal crystal oscillator output to an external crystal. If an external clock is used, leave XTAL unconnected.
PCAP	Input	Indeterminate	PLL Capacitor —PCAP is an input connecting an off-chip capacitor to the PLL filter. Connect one capacitor terminal to PCAP and the other terminal to V_{CC} . If the PLL is not used, PCAP may be tied to V_{CC} , GND, or left floating.
CLKOUT	Output	Chip-driven	Clock Output —CLKOUT provides an output clock synchronized to the internal core clock phase. When the PLL is enabled, the Division Factor (DF) equals one, and the Multiplication Factor (MF) is less than or equal to four, CLKOUT is also synchronized to EXTAL. When the PLL is disabled, the CLKOUT frequency is half the frequency of EXTAL.
PINIT/ $\overline{\text{NMI}}$	Input	Input	PLL Initial/Non-Maskable Interrupt —During assertion of $\overline{\text{RESET}}$, the value of PINIT/ $\overline{\text{NMI}}$ is written into the PLL Enable (PEN) bit of the PLL Control Register 1 (PCTL1), determining whether the PLL is enabled or disabled. After $\overline{\text{RESET}}$ deassertion and during normal instruction processing, the PINIT/ $\overline{\text{NMI}}$ Schmitt-trigger input is a negative-edge-triggered Non-Maskable Interrupt (NMI) request internally synchronized to CLKOUT. This input can tolerate 5 V.

INTERRUPT AND MODE CONTROL

Table 1-5 Interrupt And Mode Control Signals

Signal Name	Signal Type	State During Reset	Signal Description
$\overline{\text{RESET}}$	Input	Input	<p>Reset—$\overline{\text{RESET}}$ is an active low, Schmitt-trigger input. Deassertion of the $\overline{\text{RESET}}$ signal is internally synchronized to the clock out (CLKOUT). When asserted, the chip is placed in the Reset state and the internal phase generator is reset. The Schmitt-trigger input allows a slowly rising input, such as a capacitor charging, to reliably reset the chip. If the $\overline{\text{RESET}}$ signal is deasserted synchronous to CLKOUT, exact start-up timing is guaranteed, allowing multiple processors to start up synchronously and operate together. When the $\overline{\text{RESET}}$ signal is deasserted, the initial chip operating mode is latched from the MODA, MODB, MODC, and MODD inputs. In addition, the value on the PINIT/$\overline{\text{NMI}}$ pin is latched to the PEN bit in the PCTL1 register.</p> <p>This input can tolerate 5 V.</p>
MODA/ $\overline{\text{IRQA}}$	Input	Input	<p>Mode Select A/External Interrupt Request A—MODA/$\overline{\text{IRQA}}$ is an active low Schmitt-trigger input, internally synchronized to CLKOUT. MODA/$\overline{\text{IRQA}}$ selects the initial chip operating mode during hardware reset and becomes a level-sensitive or negative-edge-triggered, maskable interrupt request input during normal instruction processing. MODA, MODB, MODC, and MODD select one of sixteen initial chip operating modes latched into the Operating Mode Register (OMR) when the $\overline{\text{RESET}}$ signal is deasserted. If $\overline{\text{IRQA}}$ is asserted synchronous to CLKOUT, multiple processors can be resynchronized using the WAIT instruction and asserting $\overline{\text{IRQA}}$ to exit the Wait state. If the processor is in the Stop standby state and $\overline{\text{IRQA}}$ is asserted, the processor exits the Stop state.</p> <p>This input can tolerate 5 V.</p>

Table 1-5 Interrupt And Mode Control Signals (Continued)

Signal Name	Signal Type	State During Reset	Signal Description
MODB/ $\overline{\text{IRQB}}$	Input	Input	<p>Mode Select B/External Interrupt Request B—MODB/$\overline{\text{IRQB}}$ is an active low Schmitt-trigger input, internally synchronized to CLKOUT. MODB/$\overline{\text{IRQB}}$ selects the initial chip operating mode during hardware reset and becomes a level-sensitive or negative-edge-triggered, maskable interrupt request input during normal instruction processing. MODA, MODB, MODC, and MODD select one of sixteen initial chip operating modes latched into the OMR when the $\overline{\text{RESET}}$ signal is deasserted. If $\overline{\text{IRQB}}$ is asserted synchronous to CLKOUT, multiple processors can be resynchronized using the WAIT instruction and asserting $\overline{\text{IRQB}}$ to exit the Wait state.</p> <p>This input can tolerate 5 V.</p>
MODC/ $\overline{\text{IRQC}}$	Input	Input	<p>Mode Select C/External Interrupt Request C—MODC/$\overline{\text{IRQC}}$ is an active low Schmitt-trigger input, internally synchronized to CLKOUT. MODC/$\overline{\text{IRQC}}$ selects the initial chip operating mode during hardware reset and becomes a level-sensitive or negative-edge-triggered, maskable interrupt request input during normal instruction processing. MODA, MODB, MODC, and MODD select one of sixteen initial chip operating modes latched into the OMR when the $\overline{\text{RESET}}$ signal is deasserted. If $\overline{\text{IRQC}}$ is asserted synchronous to CLKOUT, multiple processors can be resynchronized using the WAIT instruction and asserting $\overline{\text{IRQC}}$ to exit the Wait state.</p> <p>This input can tolerate 5 V.</p>
MODD/ $\overline{\text{IRQD}}$	Input	Input	<p>Mode Select D/External Interrupt Request D MODD/$\overline{\text{IRQD}}$ is an active low Schmitt-trigger input, internally synchronized to CLKOUT. MODD/$\overline{\text{IRQD}}$ selects the initial chip operating mode during hardware reset and becomes a level-sensitive or negative-edge-triggered, maskable interrupt request input during normal instruction processing. MODA, MODB, MODC, and MODD select one of sixteen initial chip operating modes, latched into OMR when the $\overline{\text{RESET}}$ signal is deasserted. If $\overline{\text{IRQD}}$ is asserted synchronous to CLKOUT, multiple processors can be re-synchronized using the WAIT instruction and asserting $\overline{\text{IRQD}}$ to exit the Wait state.</p> <p>This input can tolerate 5 V.</p>

EXPANSION PORT (PORT A)**Table 1-6** Expansion Port, Port A Signals

Signal Name	Signal Type	State During Reset	Signal Description
A0–A15	Output	Set according to chip operating mode ¹	Address Bus —These active high outputs specify the address for external program memory accesses. To minimize power dissipation, A0–A15 do not change state when external memory spaces are not being accessed.
D0–D23	Bi-directional	Tri-stated	Data Bus —These active high, bidirectional input/outputs provide the bidirectional data bus for external program memory accesses. D0–D23 are tri-stated when no external bus activity occurs.
$\overline{\text{MCS}}$	Output	Pulled high internally	Memory Chip Select —This signal is an active low output, and is asserted when an external memory access occurs.
$\overline{\text{RD}}$	Output	Pulled high internally	Read Enable —This signal is an active low output. $\overline{\text{RD}}$ is asserted to read external memory on the data bus (D0–D23).
$\overline{\text{WR}}$	Output	Pulled high internally	Write Enable —This signal is an active low output. $\overline{\text{WR}}$ is asserted to write external memory on the data bus (D0–D23).
$\overline{\text{AT}}$	Output	Pulled high internally	Address Tracing —This signal is an active low output. $\overline{\text{AT}}$ is asserted (for half of a clock cycle) whenever a new address is driven on the address bus (A0–A15) in the Program Address Tracing mode. The new address is either a reflection of internal fetch or internal program space move instruction or an external address driven for an external access.
Note: 1. The A0–A15 pins are asserted according to the selected chip operating mode, as determined by the values on the MODA–MODD pins. Each mode has a different reset address. A0–A15 are latched to the value of that reset address minus 1. For example, if the reset address for a selected operating mode is \$0800, the address bus is asserted to \$07FF.			

HOST INTERFACE (HI08)

The HI08 provides a fast parallel data to 8-bit port that can be connected directly to the host bus. The HI08 supports a variety of standard buses, and can be directly connected to a number of industry standard microcomputers, microprocessors, DSPs, and DMA hardware. The direction and polarity of all pins on the HI08 is programmable. All pins also have programmable GPIO functionality.

Table 1-7 Host Interface Signals

Signal Name	Signal Type	State During Reset	Signal Description
HAD0– HAD7	Bi-directional	Tri-stated	Host Data Bus —When the HI08 is programmed to interface a non-multiplexed host bus and the HI function is selected, these signals are lines 0–7 of the Host Data bidirectional tri-state bus (HD0–HD7).
	Bi-directional		Host Address and Data Bus —When the HI08 is programmed to interface a multiplexed host bus and the HI function is selected, these signals are lines 0–7 of the Host Address/Data multiplexed bidirectional tri-state bus (HAD0–HAD7).
	Input or Output		Port B 0–7 —When the HI08 is configured as GPIO through the HI08 Port Control Register (HPCR), these signals are individually programmed as inputs or outputs through the HI08 Data Direction Register (HDDR). When configured as an input, this pin can tolerate 5 V.
HA0/ $\overline{\text{HAS}}$	Input	Tri-stated	Host Address Input 0 —When the HI08 is programmed to interface a non-multiplexed host bus and the HI function is selected, this signal is line 0 of the Host Address input bus (HA0).
	Input		Host Address Strobe —When the HI08 is programmed to interface a multiplexed host bus and the HI function is selected, this signal is the Host Address Strobe ($\overline{\text{HAS}}$) Schmitt-trigger input. The polarity of the address strobe is programmable.
	Input or Output		Port B 8 —When the HI08 is configured as GPIO through the HPCR, this signal is individually programmed as an input or output through the HDDR. When configured as an input, this pin can tolerate 5 V.

Table 1-7 Host Interface Signals (Continued)

Signal Name	Signal Type	State During Reset	Signal Description
HA1/HA8	Input	Tri-stated	Host Address Input 1 —When the HI08 is programmed to interface a non-multiplexed host bus and the HI function is selected, this signal is line one of the Host Address input bus (HA1).
	Input		Host Address 8 —When the HI08 is programmed to interface a multiplexed host bus and the HI function is selected, this signal is line eight of the input Host Address bus (HA8).
	Input or Output		Port B 9 —When the HI08 is configured as GPIO through the HPCR, this signal is individually programmed as an input or output through the HDDR. When configured as an input, this pin can tolerate 5 V.
HA2/HA9	Input	Tri-stated	Host Address Input 2 —When the HI08 is programmed to interface a non-multiplexed host bus and the HI function is selected, this signal is line two of the Host Address input bus (HA2).
	Input		Host Address 9 —When the HI08 is programmed to interface a multiplexed host bus and the HI function is selected, this signal is line nine of the input Host Address bus (HA9).
	Input or Output		Port B 10 —When the HI08 is configured as GPIO through the HPCR, this signal is individually programmed as an input or output through the HDDR. When configured as an input, this pin can tolerate 5 V.

Table 1-7 Host Interface Signals (Continued)

Signal Name	Signal Type	State During Reset	Signal Description
HRW/ $\overline{\text{HRD}}$	Input	Tri-stated	Host Read/Write —When the HI08 is programmed to interface a single-data-strobe host bus and the HI function is selected, this signal is the Read/ $\overline{\text{Write}}$ input (HRW).
	Input		Host Read Data —When the HI08 is programmed to interface a double-data-strobe host bus and the HI function is selected, this signal is the Read Data strobe Schmitt-trigger input ($\overline{\text{HRD}}$). The polarity of the data strobe is programmable.
	Input or Output		Port B 11 —When the HI08 is configured as GPIO through the HPCR, this signal is individually programmed as an input or output through the HDDR. When configured as an input, this pin can tolerate 5 V.
$\overline{\text{HDS}}$ / $\overline{\text{HWR}}$	Input	Tri-stated	Host Data Strobe —When the HI08 is programmed to interface a single-data-strobe host bus and the HI function is selected, this signal is the Host Data Strobe Schmitt-trigger input ($\overline{\text{HDS}}$). The polarity of the data strobe is programmable.
	Input		Host Write Enable —When the HI08 is programmed to interface a double-data-strobe host bus and the HI function is selected, this signal is the Write Data Strobe Schmitt-trigger input ($\overline{\text{HWR}}$). The polarity of the data strobe is programmable.
	Input or Output		Port B 12 —When the HI08 is configured as GPIO through the HPCR, this signal is individually programmed as an input or output through the HDDR. When configured as an input, this pin can tolerate 5 V.

Table 1-7 Host Interface Signals (Continued)

Signal Name	Signal Type	State During Reset	Signal Description
$\overline{\text{HCS}}/\text{HA10}$	Input	Tri-stated	Host Chip Select —When the HI08 is programmed to interface a non-multiplexed host bus and the HI function is selected, this signal is the Host Chip Select input ($\overline{\text{HCS}}$). The polarity of the chip select is programmable.
	Input		Host Address 10 —When the HI08 is programmed to interface a multiplexed host bus and the HI function is selected, this signal is line 10 of the input Host Address bus (HA10).
	Input or Output		Port B 13 —When the HI08 is configured as GPIO through the HPCR, this signal is individually programmed as an input or output through the HDDR. When configured as an input, this pin can tolerate 5 V.
$\overline{\text{HREQ}}/\overline{\text{HTRQ}}$	Output	Tri-stated	Host Request —When the HI08 is programmed to interface a single host request host bus and the HI function is selected, this signal is the Host Request output ($\overline{\text{HREQ}}$). The polarity of the host request is programmable. The host request can be programmed as a driven or open-drain output.
	Output		Transmit Host Request —When the HI08 is programmed to interface a double host request host bus and the HI function is selected, this signal is the Transmit Host Request output ($\overline{\text{HTRQ}}$). The polarity of the host request is programmable. The host request can be programmed as a driven or open-drain output.
	Input or Output		Port B 14 —When the HI08 is programmed to interface a multiplexed host bus and the signal is configured as GPIO through the HPCR, this signal is individually programmed as an input or output through the HDDR. When configured as an input, this pin can tolerate 5 V.

Table 1-7 Host Interface Signals (Continued)

Signal Name	Signal Type	State During Reset	Signal Description
$\overline{\text{HACK}}/\overline{\text{HRRQ}}$	Input	Tri-stated	Host Acknowledge —When the HI08 is programmed to interface a single host request host bus and the HI function is selected, this signal is the Host Acknowledge Schmitt-trigger input ($\overline{\text{HACK}}$). The polarity of the host acknowledge is programmable.
	Output		Receive Host Request —When the HI08 is programmed to interface a double host request host bus and the HI function is selected, this signal is the Receive Host Request output ($\overline{\text{HRRQ}}$). The polarity of the host request is programmable. The host request can be programmed as a driven or open-drain output.
	Input or Output		Port B 15 —When the HI08 is configured as GPIO through the HPCR, this signal is individually programmed as an input or output through the HDDR. When configured as an input, this pin can tolerate 5 V.

SYNCHRONOUS SERIAL INTERFACE 0 (SSI0)

Two identical Synchronous Serial Interfaces (SSI0 and SSI1) provide a full-duplex serial port for serial communication with a variety of serial devices including one or more industry-standard codecs, other DSPs, or microprocessors. When either SSI port is disabled, it can be used for General Purpose I/O (GPIO).

Table 1-8 Synchronous Serial Interface 0 (SSI0)

Signal Name	Signal Type	State During Reset	Signal Description
SC00	Input or Output	Tri-stated	Serial Control Signal 0 —The function of SC00 is determined by the selection of either Synchronous or Asynchronous mode. For Asynchronous mode, this signal is used for the receive clock I/O (Schmitt-trigger input). For Synchronous mode, this signal is used for or for Serial I/O Flag 0.
	Input or Output		<p>Port C 0—When configured as PC0, signal direction is controlled through the SSI0 Port Direction Control Register (PRRC). The signal can be configured as SSI signal SC00 through the SSI0 Port Control Register (PCRC).</p> <p>When configured as an input, this pin can tolerate 5 V.</p>
SC01	Input or Output	Tri-stated	Serial Control Signal 1 —The function of SC00 is determined by the selection of either Synchronous or Asynchronous mode. For Asynchronous mode, this signal is used for the receive clock I/O (Schmitt-trigger input). For Synchronous mode, this signal is used for Serial I/O Flag 1.
	Input or Output		<p>Port C 1—When configured as PC1, signal direction is controlled through the PRRRC. The signal can be configured as an SSI signal SC01 through the PCRC.</p> <p>When configured as an input, this pin can tolerate 5 V.</p>

Table 1-8 Synchronous Serial Interface 0 (SSIO) (Continued)

Signal Name	Signal Type	State During Reset	Signal Description
SC02	Input or Output	Tri-stated	Serial Control Signal 2 —SC02 is the frame sync for both the transmitter and receiver in Synchronous mode, and for the transmitter only in Asynchronous mode. When configured as an output, this signal is the internally generated frame sync signal. When configured as an input, this signal receives an external frame sync signal for the transmitter (and the receiver in synchronous operation).
	Input or Output		Port C 2 —When configured as PC2, signal direction is controlled through the PRRC. The signal can be configured as an SSI signal SC02 through the PCRC. When configured as an input, this pin can tolerate 5 V.
SCK0	Input or Output	Tri-stated	Serial Clock —SCK0 is a bidirectional Schmitt-trigger input signal providing the serial bit rate clock for the SSI interface. The SCK0 is a clock input or output used by both the transmitter and receiver in Synchronous modes, or by the transmitter in Asynchronous modes. Although an external serial clock can be independent of and asynchronous to the DSP system clock, it must exceed the minimum clock cycle time of 6T (i.e., the system clock frequency must be at least three times the external SSI clock frequency). The SSI needs at least three DSP phases inside each half of the serial clock.
	Input or Output		Port C 3 —When configured as PC3, signal direction is controlled through the PRRC. The signal can be configured as an SSI signal SCK0 through the PCRC. When configured as an input, this pin can tolerate 5 V.
SRD0	Input	Tri-stated	Serial Receive Data —SRD0 receives serial data and transfers the data to the SSI Receive Shift Register.
	Input or Output		Port C 4 —When configured as PC4, signal direction is controlled through the PRRC. The signal can be configured as an SSI signal SRD0 through the PCRC. When configured as an input, this pin can tolerate 5 V.

Table 1-8 Synchronous Serial Interface 0 (SSI0) (Continued)

Signal Name	Signal Type	State During Reset	Signal Description
STD0	Output Input or Output	Tri-stated	Serial Transmit Data —STD0 is used for transmitting data from the SSI Transmit Shift Register. Port C 5 —When configured as PC5, signal direction is controlled through the PRRC. The signal can be configured as an SSI signal STD0 through the PCRC. When configured as an input, this pin can tolerate 5 V.

SYNCHRONOUS SERIAL INTERFACE 1 (SSI1)

Table 1-9 Synchronous Serial Interface 1 (SSI1)

Signal Name	Signal Type	State during Reset	Signal Description
SC10	Input or Output	Tri-stated	<p>Serial Control Signal 0—The function of SC10 is determined by the selection of either Synchronous or Asynchronous mode. For Asynchronous mode, this signal is used for the receive clock I/O (Schmitt-trigger input). For Synchronous mode, this signal is used for or for Serial I/O Flag 0.</p>
	Input or Output		<p>Port D 0—When configured as PD0, signal direction is controlled through the SSI1 Port Direction Control Register (PRRD). The signal can be configured as SSI signal SC10 through the SSI1 Port Control Register (PCRD).</p> <p>When configured as an input, this pin can tolerate 5 V.</p>
SC11	Input or Output	Tri-stated	<p>Serial Control Signal 1—The function of SC11 is determined by the selection of either Synchronous or Asynchronous mode. For Asynchronous mode, this signal is used for the receive clock I/O (Schmitt-trigger input). For Synchronous mode, this signal is used for Serial I/O Flag 1.</p>
	Input or Output		<p>Port D 1—When configured as PD1, signal direction is controlled through the PRRD. The signal can be configured as an SSI signal SC11 through the PCRD.</p> <p>When configured as an input, this pin can tolerate 5 V.</p>
SC12	Input or Output	Tri-stated	<p>Serial Control Signal 2—SC12 is used for frame sync I/O. SC12 is the frame sync for both the transmitter and receiver in Synchronous mode, and for the transmitter only in Asynchronous mode. When configured as an output, this signal is the internally generated frame sync signal. When configured as an input, this signal receives an external frame sync signal for the transmitter (and the receiver in synchronous operation).</p>
	Input or Output		<p>Port D 2—When configured as PD2, signal direction is controlled through the PRRD. The signal can be configured as an SSI signal SC12 through the PCRD.</p> <p>When configured as an input, this pin can tolerate 5 V.</p>

Table 1-9 Synchronous Serial Interface 1 (SSI1) (Continued)

Signal Name	Signal Type	State during Reset	Signal Description
SCK1	Input or Output	Tri-stated	<p>Serial Clock—SCK1 is a bidirectional Schmitt-trigger input signal providing the serial bit rate clock for the SSI interface. The SCK1 is a clock input or output used by both the transmitter and receiver in Synchronous modes, or by the transmitter in Asynchronous modes.</p> <p>Although an external serial clock can be independent of and asynchronous to the DSP system clock, it must exceed the minimum clock cycle time of 6T (i.e., the system clock frequency must be at least three times the external SSI clock frequency). The SSI needs at least three DSP phases inside each half of the serial clock.</p>
	Input or Output		<p>Port D 3—When configured as PD3, signal direction is controlled through the PRRD. The signal can be configured as an SSI signal SCK1 through the PCRD.</p> <p>When configured as an input, this pin can tolerate 5 V.</p>
SRD1	Input	Tri-stated	<p>Serial Receive Data—SRD1 receives serial data and transfers the data to the SSI Receive Shift Register.</p>
	Input or Output		<p>Port D 4—When configured as PD4, signal direction is controlled through the PRRD. The signal can be configured as an SSI signal SRD1 through the PCRD.</p> <p>When configured as an input, this pin can tolerate 5 V.</p>
STD1	Output	Tri-stated	<p>Serial Transmit Data—STD1 is used for transmitting data from the SSI Transmit Shift Register.</p>
	Input or Output		<p>Port D 5—When configured as PD5, signal direction is controlled through the PRRD. The signal can be configured as an SSI signal STD1 through the PCRD.</p> <p>When configured as an input, this pin can tolerate 5 V.</p>

GENERAL PURPOSE I/O, GPIO

Three dedicated General Purpose Input/Output (GPIO) signals are provided on the DSP56603. Each is reconfigurable as input, output, or tri-state. These signals are exclusively defined as GPIO, and do not offer additional functionality.

Table 1-10 General Purpose I/O (GPIO)

Signal Name	Signal Type	State during Reset	Signal Description
GPIO0	Input or Output	Input	<p>General Purpose I/O —When a GPIO signal is used as input, the logic state is reflected to an internal register and can be read by the software. When a GPIO signal is used as output, the logic state is controlled by the software.</p> <p>This input can tolerate 5 V.</p>
GPIO1	Input or Output	Input	<p>General Purpose I/O —When a GPIO signal is used as input, the logic state is reflected to an internal register and can be read by the software. When a GPIO signal is used as output, the logic state is controlled by the software.</p> <p>This input can tolerate 5 V.</p>
GPIO2	Input or Output	Input	<p>General Purpose I/O —When a GPIO signal is used as input, the logic state is reflected to an internal register and can be read by the software. When a GPIO signal is used as output, the logic state is controlled by the software.</p> <p>This input can tolerate 5 V.</p>

TRIPLE TIMER

Three identical and independent timers are implemented. The three timers can use internal or external clocking and can interrupt the DSP after a specified number of events (clocks), or can signal an external device after counting a specific number of internal events. When a timer port is disabled, it can be used for General Purpose I/O (GPIO).

Table 1-11 Triple Timer Signals

Signal Name	Signal Type	State during Reset	Signal Description
TIO0	Input or Output	GPIO Input	Timer 0 Schmitt-Trigger Input/Output —When TIO0 is used as an input, the timer module functions as an external event counter or measures external pulse width or signal period. When TIO0 is used as an output, the timer module functions as a timer and TIO0 provides the timer pulse.
	Input or Output		When the TIO0 is not used by the timer module, it can be used for GPIO. When configured as an input, this pin can tolerate 5 V.
TIO1	Input or Output	GPIO Input	Timer 1 Schmitt-Trigger Input/Output —When TIO1 is used as an input, the timer module functions as an external event counter or measures external pulse width or signal period. When TIO1 is used as an output, the timer module functions as a timer and TIO1 provides the timer pulse.
	Input or Output		When TIO1 is not used by the timer module, it can be used for GPIO. When configured as an input, this pin can tolerate 5 V.
TIO2	Input or Output	GPIO Input	Timer 2 Schmitt-Trigger Input/Output —When TIO2 is used as an input, the timer module functions as an external event counter or measures external pulse width or signal period. When TIO2 is used as an output, the timer module functions as a timer and TIO2 provides the timer pulse.
	Input or Output		When TIO2 is not used by the timer module, it can be used for GPIO. When configured as an input, this pin can tolerate 5 V.

JTAG/OnCE INTERFACE

Table 1-12 JTAG/On-Chip Emulation (OnCE) Interface Signals

Signal Name	Signal Type	State During Reset	Signal Description
TCK	Input	Input	<p>Test Clock—TCK is a test clock input signal used to synchronize the JTAG test logic. The TCK pin can be tri-stated.</p> <p>This input can tolerate 5 V.</p>
TDI	Input	Input	<p>Test Data Input— TDI is a test data serial input signal used for test instructions and data. TDI is sampled on the rising edge of the TCK signal and has an internal pull-up resistor.</p> <p>This input can tolerate 5 V.</p>
TDO	Output	Tri-state	<p>Test Data Output— TDO is a test data serial output signal used for test instructions and data. TDO is tri-stateable and is actively driven in the shift-IR and shift-DR controller states. TDO changes on the falling edge of the TCK signal.</p>
TMS	Input	Input	<p>Test Mode Select— TMS is an input signal used to sequence the test controller's state machine. TMS is sampled on the rising edge of the TCK signal and has an internal pull-up resistor.</p> <p>This input can tolerate 5 V.</p>
$\overline{\text{TRST}}$	Input	Input	<p>Test Reset—$\overline{\text{TRST}}$ is an active-low Schmitt-trigger input signal used to asynchronously initialize the test controller. $\overline{\text{TRST}}$ has an internal pull-up resistor. $\overline{\text{TRST}}$ must be asserted during the power up sequence.</p> <p>This input can tolerate 5 V.</p>
$\overline{\text{DE}}$	Bi-directional	Input	<p>Debug Event—$\overline{\text{DE}}$ is an open-drain bidirectional active-low signal providing, as an input, a means of entering the Debug mode of operation from an external command controller, and as an output, a means of acknowledging that the chip has entered the Debug mode. The $\overline{\text{DE}}$ has an internal pull-up resistor.</p> <p>When this pin is an input, it can tolerate 5 V.</p>

SECTION 2

SPECIFICATIONS

GENERAL CHARACTERISTICS

The DSP56603 is fabricated in high-density CMOS with Transistor-Transistor Logic (TTL)-compatible inputs and outputs.

Functional operating conditions are given in **Table 2-4** on page 2-3. Absolute maximum ratings given in **Table 2-1** are stress ratings only, and functional operation at the maximum is not guaranteed. Stress beyond these ratings may affect device reliability or cause permanent damage to the device.

The DSP56603 DC/AC electrical specifications are preliminary and are from design simulations. These specifications may not be fully tested or guaranteed at this early stage of the product life cycle. Finalized specifications will be published after complete characterization and device qualifications have been completed.

Table 2-1 Absolute Maximum Ratings (GND = 0 V)

Rating	Symbol	Value	Unit
Supply Voltage	V_{CC}	-0.3 to +4	V
All Input Voltages Excluding "5 Volt Tolerant" Inputs	V_{IN}	GND - 0.3 to $V_{CC} + 0.3$	V
All "5 Volt Tolerant" Inputs Voltages ¹	V_{IN5}	GND - 0.3 to $V_{CC} + 3.95$	V
Current Drain per Pin Excluding V_{CC} and GND	I	10	mA
Operating Temperature Range	T_A	-40 to 85	°C
Storage Temperature	T_{stg}	-55 to +150	°C
Note: 1. "5 Volt Tolerant" inputs are inputs that tolerate 5 V. All "5 Volt Tolerant" input voltages cannot be more than 3.95 V greater than supply voltage. This restriction applies to power-on, as well as to normal operation.			

CAUTION

This device contains protective circuitry to guard against damage due to high static voltage or electrical fields. However, normal precautions are advised to avoid application of any voltages higher than maximum rated voltages to this high-impedance circuit. Reliability of operation is enhanced if unused inputs are tied to an appropriate logic voltage level (e.g., either or V_{CC} or GND).

Table 2-2 Recommended Operating Conditions

Rating	Symbol	Value	Unit
Supply Voltage	V_{CC}	2.7 to 3.3	V
Ambient Temperature	T_A	-40 to +85	°C

Table 2-3 Package Thermal Characteristics

Thermal Resistance ¹	144-pin TQFP		
	Symbol	Value	Units
Junction-to-ambient thermal resistance ²	$R_{\theta JA}$ or θ_{JA}	49.3	°C/W
Junction-to-case thermal resistance ³	$R_{\theta JC}$ or θ_{JC}	8.2	°C/W
Thermal characterization parameter	Ψ_{JT}	5.5	°C/W
Notes: 1. See discussion under Heat Dissipation on page 4-1. 2. Junction-to-ambient thermal resistance is based on measurements on a horizontal single-sided printed circuit board per SEMI G38-87 in natural convection. 3. Junction-to-case thermal resistance is based on measurements using a cold plate per SEMI G30-88, with the exception that the cold plate temperature is used for the case temperature. 4. Thermal Characterization Parameter, Ψ_{JT} , is defined in EIA/JESD 51-2. It is a measure of the difference in temperature between the junction and a thermocouple on top of the package normalized by the power dissipation. 5. SEMI is Semiconductor Equipment and Materials International, 805 East Middlefield Road, Mountain View, CA 94043, (415) 964-5111. 6. MIL-SPEC and EIA/JESD (JEDEC) specifications are available from Global Engineering Documents at (800) 854-7179 or (303) 397-7956.			

DC ELECTRICAL CHARACTERISTICS

($V_{CC} = 3.0 \text{ V} \pm 0.3 \text{ V}$; $T_A = -40^\circ \text{ to } 85^\circ \text{C}$, $C_L = 50 \text{ pF} + 2 \text{ TTL Loads}$)

Table 2-4 DC Electrical Characteristics for the DSP56603

Characteristics	Symbol	Min	Typ	Max	Unit
Supply Voltage for V_{CCA} , V_{CC} , V_{CCD} , V_{CCH} , V_{CCP} , V_{CCQH} , V_{CCQL} , and V_{CCS} ¹	V_{CC}	2.7	3.0	3.3	V
Input High Voltage					
• D0–D23	V_{IH}	2.0	—	V_{CC}	V
• $\overline{\text{MOD}}/\overline{\text{IRQ}}^2$, $\overline{\text{RESET}}$, $\overline{\text{PINIT}}/\overline{\text{NMI}}$, and all JTAG/HI08/SSI/Timer/GPIO pins	V_{IHP}	2.0	—	5.75	V
• EXTAL	V_{IHx}	$V_{CC} - 0.4$	—	V_{CC}	V
Input Low Voltage					
• D0–D23, $\overline{\text{MOD}}/\overline{\text{IRQ}}^2$, $\overline{\text{RESET}}$, $\overline{\text{PINIT}}/\overline{\text{NMI}}$	V_{IL}	-0.3	—	0.8	V
• all JTAG/HI08/SSI/Timer/GPIO pins	V_{ILP}	-0.3	—	0.8	V
• EXTAL	V_{ILx}	-0.3	—	0.4	V
Input Leakage Current	I_{IN}	-10.0	—	10.0	μA
High-Impedance (Off State) Input Current (2.4 V/0.4 V)	I_{TSI}	-10.0	—	10.0	μA
Output High Voltage ($I_{OH} = -0.4 \text{ mA}$)	V_{OH}	2.4	—	—	V
Output Low Voltage ($I_{OL} = 3.0 \text{ mA}$, Open Drain Pins $I_{OL} = 6.7 \text{ mA}$)	V_{OL}	—	—	0.4	V
Internal Supply Current at 60 MHz					
• in Normal Mode ^{3, 6}	I_{CCI}	—	57	—	mA
• in Wait Mode ^{4, 6}	I_{CCW}	—	4.6	—	mA
• in Stop Mode ^{5, 6}	I_{CCS}	—	50	—	μA
PLL Supply Current in Stop Mode (PLL on) ⁶	I_{PLL}	—	3.5	—	mA
Input Capacitance ⁶	C_{IN}	—	—	10	pF
Notes:	<ol style="list-style-type: none"> Throughout the data sheet, assume that V_{CCA}, V_{CC}, V_{CCD}, V_{CCH}, V_{CCP}, V_{CCQH}, V_{CCQL}, and V_{CCS} power pins have the same voltage level. This specification applies to $\overline{\text{MODA}}/\overline{\text{IRQA}}$, $\overline{\text{MODB}}/\overline{\text{IRQB}}$, $\overline{\text{MODC}}/\overline{\text{IRQC}}$, and $\overline{\text{MODD}}/\overline{\text{IRQD}}$ pins. Power Consumption Considerations on page 4-5 provides a formula to compute the estimated current requirements in Normal mode. In order to obtain these results, all inputs must be terminated (i.e., not allowed to float). Measurements are based on synthetic intensive DSP benchmarks (see Appendix A). The power consumption numbers in this specification are 90% of the measured results of this benchmark. This reflects typical DSP applications. Typical internal supply current is measured with $V_{CC} = 2.7 \text{ V}$ at $T_J = 100^\circ \text{C}$. The actual current consumption varies with the operating conditions and the program being executed. In order to obtain these results, all inputs must be terminated (i.e., not allowed to float). In order to obtain these results, all inputs that are not disconnected at Stop mode must be terminated. These values are periodically sampled and not 100% tested. 				

AC ELECTRICAL CHARACTERISTICS

The timing specifications in **AC Electrical Characteristics** are tested with a V_{IL} maximum of 0.3 V and a V_{IH} minimum of 2.4 V for all pins except EXTAL, which is tested using the input levels set forth in **DC Electrical Characteristics**. AC timing specifications referenced to a device input signal are measured in production with respect to the 50% point of the respective input signal's transition. Timings specified relative to a CLKOUT edge are measured with respect to the 50% point of the applicable CLKOUT transition. All other DSP56603 output timing specifications are measured with the production test machine V_{OL} and V_{OH} reference levels set at 0.8 V and 2.0 V, respectively.

Note: Unless specifically noted otherwise, all references to CLKOUT edges assume that the PLL is enabled. All timings except those that specifically relate to the EXTAL input are guaranteed by test with the PLL enabled.

AC Electrical Characteristics—Internal Clock Operation

($V_{CC} = 3.0 \text{ V} \pm 0.3 \text{ V}$; $T_A = -40^\circ \text{ to } 85^\circ \text{C}$, $C_L = 50 \text{ pF} + 2 \text{ TTL Loads}$)

For each occurrence of T_H , T_L , T_C , or I_{CYC} , substitute the numbers given in **Table 2-5**. (The terms E_f , ET_H , ET_L , and ET_C are described in **Table 2-6**.)

Table 2-5 Internal Clocks

Characteristics	Symbol	Expression
Internal Operation Frequency With PLL Enabled	f	$(E_f \times MF^1) / (PDF^2 \times DF^3)$
Internal Operation Frequency With PLL Disabled	f	$E_f / 2$
Internal Clock High Period <ul style="list-style-type: none"> • PLL disabled • PLL enabled and $MF \leq 4$ • PLL enabled and $MF > 4$ 	T_H	ET_C (Min) $0.49 \times ET_C \times PDF \times DF / MF$ (Max) $0.51 \times ET_C \times PDF \times DF / MF$ (Min) $0.47 \times ET_C \times PDF \times DF / MF$ (Max) $0.53 \times ET_C \times PDF \times DF / MF$
Internal Clock Low Period <ul style="list-style-type: none"> • PLL disabled • PLL enabled and $MF \leq 4$ • PLL enabled and $MF > 4$ 	T_L	ET_C (Min) $0.49 \times ET_C \times PDF \times DF / MF$ (Max) $0.51 \times ET_C \times PDF \times DF / MF$ (Min) $0.47 \times ET_C \times PDF \times DF / MF$ (Max) $0.53 \times ET_C \times PDF \times DF / MF$

Table 2-5 Internal Clocks (Continued)

Characteristics	Symbol	Expression
Internal Clock Cycle Time With PLL Enabled	T_C	$ET_C \times PDF \times DF / MF$
Internal Clock Cycle Time With PLL Disabled	T_C	$2 \times ET_C$
Instruction Cycle Time	I_{CYC}	T_C
Notes: 1. MF represents the PLL Multiplication Factor. 2. PDF represents the PLL Predivision Factor. 3. DF represents the PLL Division Factor.		

AC Electrical Characteristics—External Clock Operation

($V_{CC} = 3.0 \text{ V} \pm 0.3 \text{ V}$; $T_A = -40^\circ$ to 85°C , $C_L = 50 \text{ pF} + 2 \text{ TTL Loads}$)

The DSP56603 system clock can be derived from the on-chip crystal oscillator, or it can be externally supplied. An externally supplied square wave voltage source should be connected to EXTAL, leaving XTAL physically not connected to the board or socket (see **Figure 2-1** on page 2-6). The rise and fall time of this external clock should be 3 ns maximum.

Table 2-6 Clock Operation

Num	Characteristics	Symbol	Min	Max	Unit
1	Frequency of EXTAL (EXTAL Pin Frequency)	E_f	0	60.0	MHz
2	Clock Input High ^{1, 2} <ul style="list-style-type: none"> • PLL disabled (46.7–53.3% duty cycle) • PLL enabled (42.5–57.5% duty cycle, at 60 MHz) 	ET_H	7.8 7.1	∞ 157.0 μs	ns
3	Clock Input Low ^{1, 2} <ul style="list-style-type: none"> • PLL disabled (46.7–53.3% duty cycle) • PLL enabled (42.5–57.5% duty cycle) 	ET_L	7.8 7.1	∞ 157.0 μs	ns
4	Clock Cycle Time ² <ul style="list-style-type: none"> • PLL disabled • PLL enabled 	ET_C	16.7 16.7	∞ 273.1 μs	ns
5	CLKOUT Change from EXTAL Fall, PLL disabled	—	4.3	11.0	ns
6	CLKOUT from EXTAL with PLL enabled ($MF = PDF \times DF$, $MF \leq 4$, $E_f > 15 \text{ MHz}$) ⁴	—	0	1.8	ns
7	Instruction Cycle Time = $I_{CYC} = T_C$ ^{1, 3} <ul style="list-style-type: none"> • PLL disabled • PLL enabled 	I_{CYC}	33.3 16.7	∞ 8.53 μs	ns

Specifications

AC Electrical Characteristics

Table 2-6 Clock Operation (Continued)

Num	Characteristics	Symbol	Min	Max	Unit
Notes:	1. External Clock Input High, External Clock Input Low, and CLKOUT are measured at 50% of the signal transition. 2. The maximum value for PLL enabled is given for minimum VCO and maximum MF. 3. The maximum value for PLL enabled is given for minimum VCO and maximum DF. 4. These timings are periodically sampled and not 100% tested.				

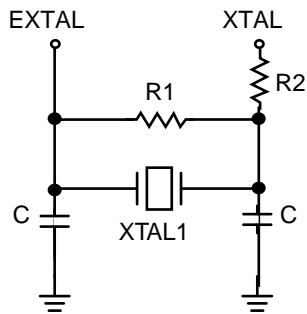

**Fundamental Frequency
Fork Crystal Oscillator**

Suggested Component Values:

$$f_{OSC} = 32.768 \text{ kHz}$$

$$R1 = 3.9 \text{ M}\Omega \pm 10\%$$

$$R2 = 200 \text{ k}\Omega \pm 10\%$$

$$C = 22 \text{ pF} \pm 20\%$$

Calculations were done for a 32.768 kHz crystal with the following parameters: a load capacitance (C_L) of 12.5 pF, a shunt capacitance (C_0) of 1.8 pF, a series resistance of 40 k Ω , and drive level of 1 μ W.

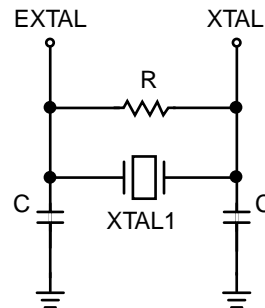

**Fundamental Frequency
Crystal Oscillator**

Suggested Component Values:

$$f_{OSC} = 4 \text{ MHz}$$

$$R = 680 \text{ k}\Omega \pm 10\%$$

$$C = 56 \text{ pF} \pm 20\%$$

$$f_{OSC} = 20 \text{ MHz}$$

$$R = 680 \text{ k}\Omega \pm 10\%$$

$$C = 22 \text{ pF} \pm 20\%$$

Calculations were done for a 4/20 MHz crystal with the following parameters: a load capacitance (C_L) of 30/20 pF, a shunt capacitance (C_0) of 7/6 pF, a series resistance of 100/20 Ω , and drive level of 2 mW.

AA0458

Figure 2-1 Crystal Oscillator Circuits

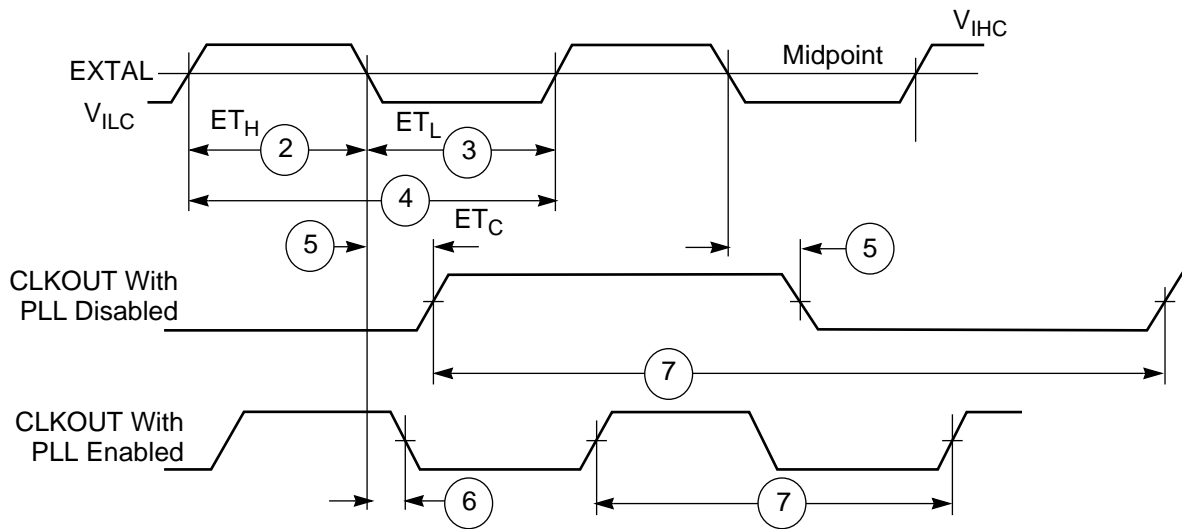

Note: The midpoint is $0.5 (V_{IHC} + V_{ILC})$.

AA0367

Figure 2-2 External Clock Timing

AC Electrical Characteristics—Phase Lock Loop (PLL) Characteristics

($V_{CC} = 3.0 \text{ V} \pm 0.3 \text{ V}$; $T_A = -40^\circ \text{ to } 85^\circ \text{ C}$, $C_L = 50 \text{ pF} + 2 \text{ TTL Loads}$)

Table 2-7 Phase Lock Loop Characteristics

Characteristics	Expression	Min	Max	Unit
VCO frequency when PLL enabled ¹	$MF \times Ef \times 2 / PDF$	30	120	MHz
PLL external capacitor (PCAP pin to V_{CCP}) <ul style="list-style-type: none"> • $MF \leq 4$ • $MF > 4$ 	C_{pcap} ²	$MF \times 425 - 125$ $MF \times 520$	$MF \times 590 - 175$ $MF \times 920$	pF
Notes: 1. The VCO output is further divided by 2 when PLL is enabled. If the Division Factor (DF) is 1, the operating frequency is $\frac{VCO}{2}$.				
2. C_{pcap} is the value of the PLL capacitor (connected between PCAP pin and V_{CCP}). (The recommended value for C_{pcap} is $(500 \times MF - 150)$ pF for $MF \leq 4$ and $(690 \times MF)$ pF for $MF > 4$.)				

AC Electrical Characteristics—Reset, Stop, Mode Select, and Interrupt Timing

($V_{CC} = 3.0\text{ V} \pm 0.3\text{ V}$; $T_A = -40^\circ$ to 85°C , $C_L = 50\text{ pF} + 2\text{ TTL Loads}$)

WS = Number of Wait States (measured in clock cycles, number of T_C)

Table 2-8 Reset Timing

Num	Characteristics	Expression	60 MHz		Unit
			Min	Max	
8	Delay from $\overline{\text{RESET}}$ Assertion to All Pins at Reset Value ¹	$20.0 + T_C$	—	333.34	ns
9	Required $\overline{\text{RESET}}$ Duration ^{2, 3} <ul style="list-style-type: none"> • Power on, external clock generator, PLL disabled • Power on, external clock generator, PLL enabled • Power on, internal oscillator • During Stop, XTAL disabled • During Stop, XTAL enabled • During normal operation 	$50 \times ET_C$ $1000 \times ET_C$ $75000 \times ET_C$ $75000 \times ET_C$ $2.5 \times T_C$ $2.5 \times T_C$	833.3 16.72 1.25 1.25 41.7 41.7	— — — — — —	ns μs ms ms ns ns
10	Delay from Asynchronous $\overline{\text{RESET}}$ Deassertion to First External Address Output (Internal Reset Deassertion) ⁴ <ul style="list-style-type: none"> • Minimum • Maximum 	$3.25 \times T_C + 2.2$ $20.25T_C + 12.1$	56.4 —	— 349.6	ns ns
11	Synchronous Reset Setup Time from $\overline{\text{RESET}}$ Deassertion to first CLKOUT transition	T_C	9.0	16.7	ns
12	Synchronous Reset Deassertion, Delay Time from the first CLKOUT transition to the First External Address Output <ul style="list-style-type: none"> • Minimum • Maximum 	$3.25 \times T_C + 1.1$ $20.25T_C + 5.5$	55.3 —	— 343.0	ns ns

Notes:

1. These timings are periodically sampled and not 100% tested.
2. For an external clock generator, $\overline{\text{RESET}}$ duration is measured during the time in which $\overline{\text{RESET}}$ is asserted, V_{CC} is valid, and the EXTAL input is active and valid. For internal oscillator, $\overline{\text{RESET}}$ duration is measured during the time in which $\overline{\text{RESET}}$ is asserted and V_{CC} is valid. The specified timing reflects the crystal oscillator stabilization time after power-up. This number is affected both by the specifications of the crystal and other components connected to the oscillator and reflects worst case conditions.
3. When V_{CC} is powered up and the “Required $\overline{\text{RESET}}$ Duration” conditions as specified above are not yet met, the device circuitry is in an uninitialized state that may result in significant power consumption. To minimize power consumption, the DSP56603 should be initialized as soon as possible to limit the duration of the uninitialized state.
4. This specification is valid if the PLL does not lose lock.

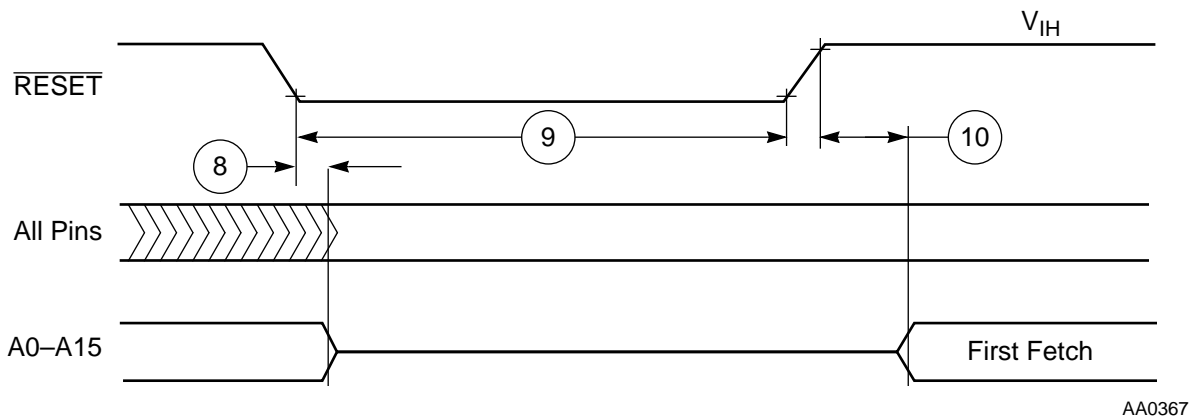

Figure 2-3 Reset Timing

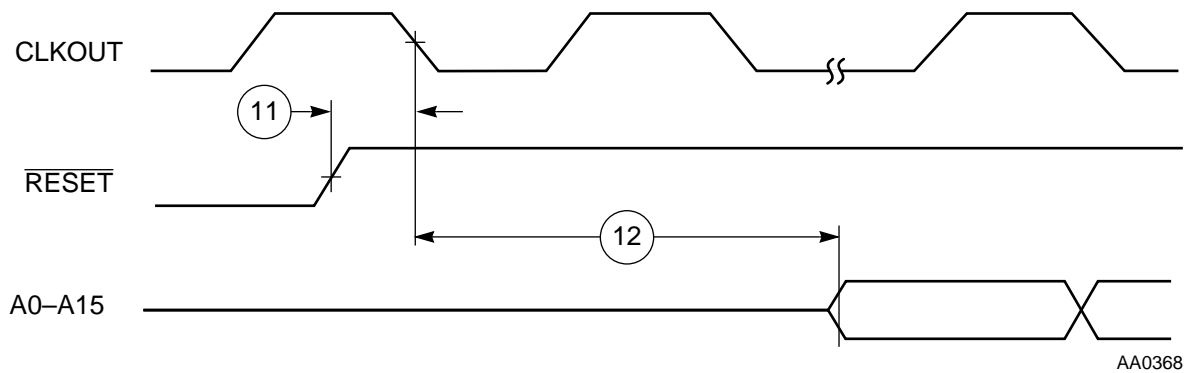

Figure 2-4 Synchronous Reset Timing

Table 2-9 Mode Select and Interrupt Timings

Num	Characteristics	Expression	60 MHz		Unit
			Min	Max	
13	Mode Select Setup Time	—	30.0	—	ns
14	Mode Select Hold Time	—	0.0	—	ns
15	Minimum Edge-Triggered Interrupt Request Assertion Width	—	10.0	—	ns
16	Minimum Edge-Triggered Interrupt Request Deassertion Width	—	10.0	—	ns
17	Delay from $\overline{\text{IRQ}}$ or $\overline{\text{NMI}}$ Assertion to External Memory Access Address Out Valid	—	—	—	—
		<ul style="list-style-type: none"> Caused by first interrupt instruction fetch Caused by first interrupt instruction execution 	$4.25 \times T_C + 2.2$ $7.25 \times T_C + 2.2$	73.0 123.0	— —

Specifications

AC Electrical Characteristics

Table 2-9 Mode Select and Interrupt Timings (Continued)

Num	Characteristics	Expression	60 MHz		Unit
			Min	Max	
18	Delay from $\overline{\text{IRQA}}$, $\overline{\text{IRQB}}$, $\overline{\text{IRQC}}$, $\overline{\text{IRQD}}$, NMI Assertion to General Purpose Transfer Output Valid caused by First Interrupt Instruction Execution	$10 \times T_C + 5.5$	172.2	—	ns
19	Delay from Address Output Valid caused by First Interrupt Instruction Execute to Interrupt Request Deassertion for Level Sensitive Fast Interrupts ¹	$3.75 \times T_C + WS \times T_C - 15.4$	—	63.8	ns
20	Delay from $\overline{\text{RD}}$ Assertion to Interrupt Request Deassertion for Level Sensitive Fast Interrupts ¹	$3.25 \times T_C + WS \times T_C - 15.4$	—	55.4	ns
21	Delay from $\overline{\text{WR}}$ Assertion to Interrupt Request Deassertion for Level Sensitive Fast Interrupts ¹ <ul style="list-style-type: none"> • SRAM WS = 1 • SRAM WS = 2, 3 • SRAM WS ≥ 4 	$(3.5 + WS) \times T_C - 15.4$ $(3.0 + WS) \times T_C - 15.4$ $(2.5 + WS) \times T_C - 15.4$	—	59.6 51.3 26.3	ns ns ns
22	Synchronous Interrupt Setup Time from $\overline{\text{IRQA}}$, $\overline{\text{IRQB}}$, $\overline{\text{IRQC}}$, $\overline{\text{IRQD}}$, NMI Assertion to the Second CLKOUT transition	T_C	9.0	16.7	ns
23	Synchronous Interrupt Delay Time from CLKOUT's Second Transition to the First External Address Output Valid caused by the First Instruction Fetch after coming out of Wait <ul style="list-style-type: none"> • Minimum • Maximum 	$9.25 \times T_C + 1.1$ $24.75 \times T_C + 5.5$	155.3 —	— 418.0	ns ns
24	Duration for $\overline{\text{IRQA}}$ Assertion to recover from Stop	—	9.0	—	ns
25	Delay from $\overline{\text{IRQA}}$ assertion To Fetch of First Instruction (when exiting Stop) ^{2,3} <ul style="list-style-type: none"> • PLL not active during Stop and Stop Delay enabled (PCTL1 Bit 6 = 0, OMR Bit 6 = 0) • PLL not active during Stop, Stop Delay not enabled (PCTL1 Bit 6 = 0, OMR Bit 6 = 1) • PLL active during Stop, no Stop Delay (PCTL1 Bit 6 = 1) 	$PLC \times ET_C \times PDF + (128K - PLC/2) \times T_C$ $PLC \times ET_C \times PDF + (23.75 \pm 0.5) \times T_C$ $PLC \times ET_C (8.25 \pm 0.5) \times T_C$	2.2 388.3 ns 129.2	22.6 20.4 ms 145.8	ms ns

Table 2-9 Mode Select and Interrupt Timings (Continued)

Num	Characteristics	Expression	60 MHz		Unit
			Min	Max	
26	Duration of Level-Sensitive $\overline{\text{IRQA}}$ Assertion to Ensure Interrupt Service (when exiting Stop) ^{2,3}				
	<ul style="list-style-type: none"> • PLL not active during Stop, Stop Delay enabled (PCTL1 Bit 6 = 0, OMR Bit 6 = 0) 	$\text{PLC} \times \text{ET}_C \times \text{PDF} + (128\text{K} - \text{PLC}/2) \times \text{T}_C$	22.6	—	ns
	<ul style="list-style-type: none"> • PLL not active during Stop, Stop Delay not enabled (PCTL1 Bit 6 = 0, OMR Bit 6 = 1) 	$\text{PLC} \times \text{ET}_C \times \text{PDF} + (20.5 \pm 0.5) \times \text{T}_C$	20.4	—	ns
	<ul style="list-style-type: none"> • PLL active during Stop, no Stop Delay (PCTL1 Bit 6 = 1) 	$5.5 \times \text{T}_C$	91.7	—	ns
27	Interrupt requests rate				
	<ul style="list-style-type: none"> • HI08, SSI, Timer 	12T_C	—	200.4	ns
	<ul style="list-style-type: none"> • $\overline{\text{IRQ}}$ (edge trigger) • $\overline{\text{IRQ}}$ (level trigger) 	8T_C 12T_C	— —	133.6 200.4	
Notes:	<ol style="list-style-type: none"> 1. When using fast interrupts and $\overline{\text{IRQA}}$, $\overline{\text{IRQB}}$, $\overline{\text{IRQC}}$, and $\overline{\text{IRQD}}$ are defined as level-sensitive, then timings 14 through 16 apply to prevent multiple interrupt service. To avoid these timing restrictions, the deasserted edge-triggered mode is recommended when using fast interrupts. Long interrupts are recommended when using level-sensitive mode. 2. This timing depends on several settings: <ul style="list-style-type: none"> • For PLL disabled, using internal oscillator (PLL Control Register (PCTL1) Bit 4 = 0) and oscillator disabled during Stop (PCTL1 Bit 5 = 0), a stabilization delay is required to assure the oscillator is stable before executing programs. In that case, resetting the Stop delay (OMR Bit 6 = 0) provides the proper delay. While it is possible to set OMR Bit 6 = 1, it is not recommended and these specifications do not guarantee timings for that case. • For PLL disabled, using internal oscillator (PCTL1 Bit 4 = 0) and oscillator enabled during Stop (PCTL1 Bit 5 = 1), no stabilization delay is required and recovery time is minimal (OMR Bit 6 setting is ignored). • For PLL disabled, using external clock (PCTL1 Bit 4 = 1), no stabilization delay is required and recovery time is defined by the PCTL1 Bit 6 and OMR Bit 6 settings. • For PLL disabled, using external clock (PCTL1 Bit 4 = 1), no stabilization delay is required and recovery time is defined by the PCTL1 Bit 6 and OMR Bit 6 settings. • For PLL enabled, if PCTL1 Bit 6 is 0, the PLL is shut down during Stop. Recovering from Stop requires the PLL to re-lock. The PLL lock procedure duration, PLC (PLL Lock Cycles), may be in the range of 0 to 300 cycles. This procedure occurs in parallel to the Stop Delay counter, and Stop recovery ends when the last of these two events occurs (the Stop Delay counter completes its count, or the PLL lock procedure completes). • PLC value for PLL disabled is 0. • Maximum value for ET_C is 4096 (maximum multiplication factor) divided by the desired internal frequency (i.e., for 60 MHz it is $4096/60 \text{ MHz} = 68.26 \mu\text{s}$). During the stabilization period, T_C, T_H, and T_L will not be constant. Their width may vary, so timing may vary as well. 3. These timings are periodically sampled and not 100% tested. 				

AC Electrical Characteristics

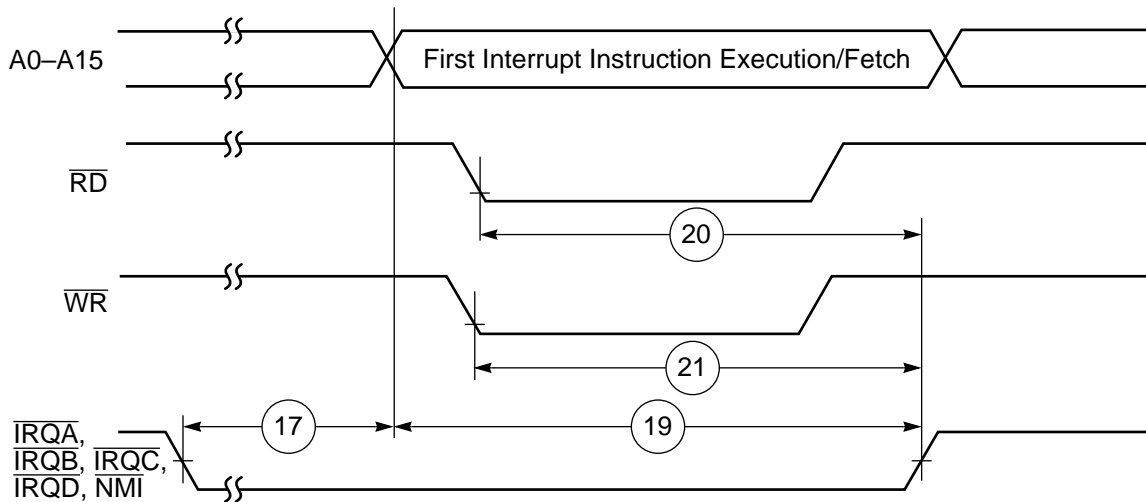

a) First Interrupt Instruction Execution

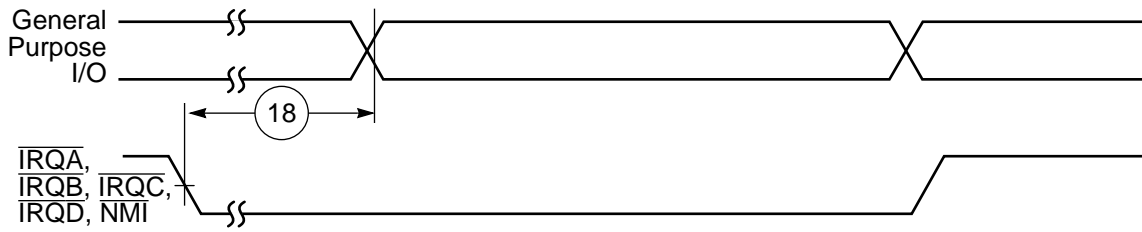

b) General Purpose I/O

AA0369

Figure 2-5 External Level—Sensitive Fast Interrupt Timing

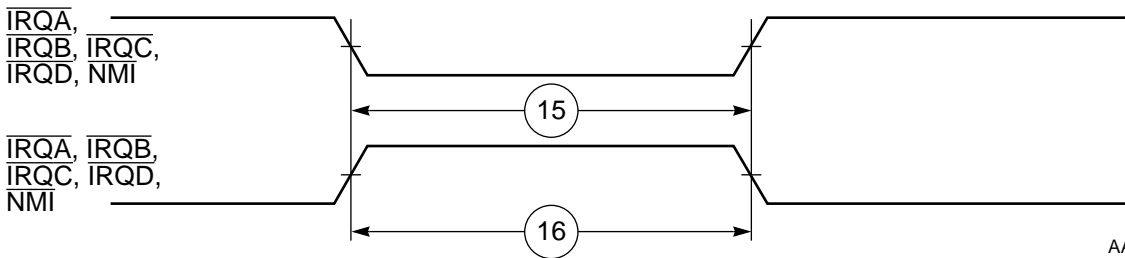

AA0370

Figure 2-6 External Interrupt Timing (Negative Edge-Triggered)

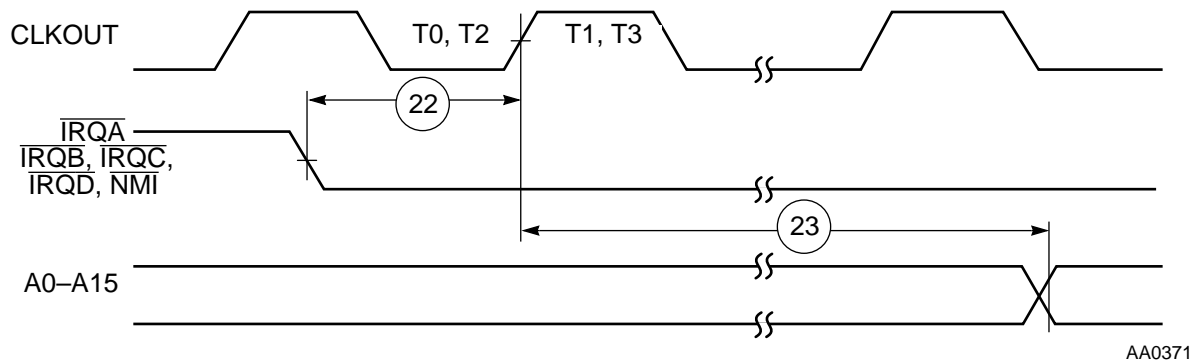

AA0371

Figure 2-7 Synchronous Interrupt from Wait Timing

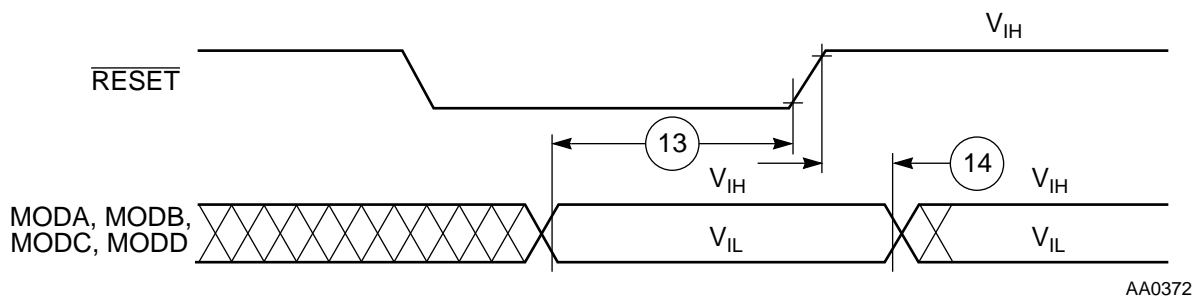

AA0372

Figure 2-8 Operating Mode Select Timing

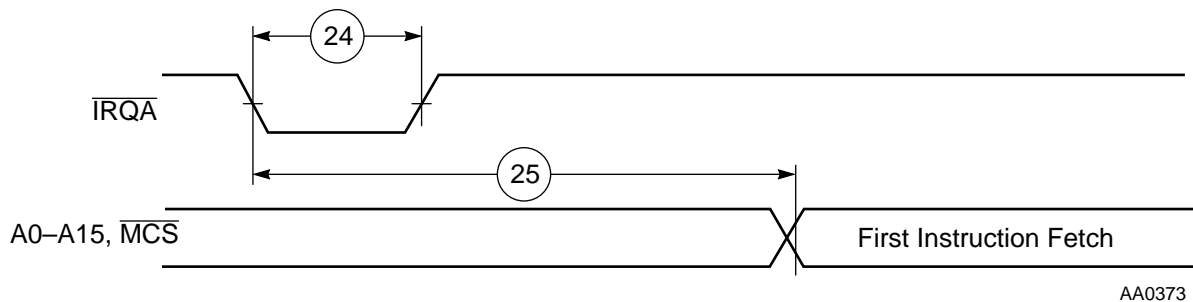

AA0373

Figure 2-9 Recovery from Stop Using $\overline{\text{IRQA}}$

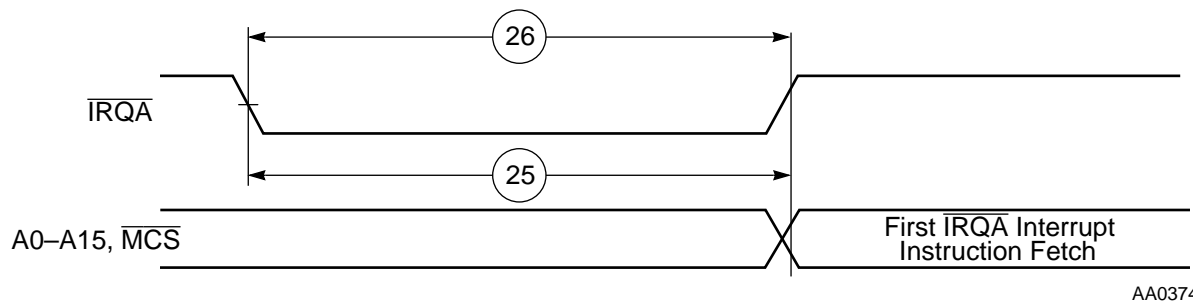

AA0374

Figure 2-10 Recovery from Stop Using $\overline{\text{IRQA}}$ Interrupt Service

Specifications

AC Electrical Characteristics

AC Electrical Characteristics—Port A

($V_{CC} = 3.0 \text{ V} \pm 0.3 \text{ V}$; $T_A = -40^\circ \text{ to } 85^\circ \text{C}$, $C_L = 50 \text{ pF} + 2 \text{ TTL Loads}$)

Table 2-10 SRAM Read and Write Access

Num	Characteristics	Symbol	Expression	60 MHz		Unit
				Min	Max	
100	Address Valid and $\overline{\text{MCS}}$ Assertion Pulse Width <ul style="list-style-type: none"> $1 \leq \text{WS} \leq 3$ $4 \leq \text{WS} \leq 7$ $\text{WS} \geq 8$ 	t_{RC} , t_{WC}	$(\text{WS} + 1) \times T_C - 4.4$ $(\text{WS} + 2) \times T_C - 4.4$ $(\text{WS} + 3) \times T_C - 4.4$	28.9 95.6 178.9	— — —	ns
101	Address Valid and $\overline{\text{MCS}}$ Assertion to $\overline{\text{WR}}$ Assertion <ul style="list-style-type: none"> $\text{WS} = 1$ $2 \leq \text{WS} \leq 3$ $\text{WS} \geq 4$ 	t_{AS}	$0.25 \times T_C - 3.7$ $0.75 \times T_C - 4.4$ $1.25 \times T_C - 4.4$	0.5 8.1 16.4	— — —	ns
102	$\overline{\text{WR}}$ Assertion Pulse Width <ul style="list-style-type: none"> $\text{WS} = 1$ $2 \leq \text{WS} \leq 3$ $\text{WS} \geq 4$ 	t_{WP}	$1.5 \times T_C - 5.7$ $\text{WS} \times T_C - 4.4$ $(\text{WS} - 0.5) \times T_C - 4.4$	19.3 28.9 53.9	— — —	ns
103	$\overline{\text{WR}}$ Deassertion to Address Invalid and $\overline{\text{MCS}}$ Deassertion <ul style="list-style-type: none"> $1 \leq \text{WS} \leq 3$ $4 \leq \text{WS} \leq 7$ $\text{WS} \geq 8$ 	t_{WR}	$0.25 \times T_C - 3.8$ $1.25 \times T_C - 4.4$ $2.25 \times T_C - 4.4$	0.4 16.4 33.1	— — —	ns
104	Address and $\overline{\text{MCS}}$ Valid to Input Data Valid, $\text{WS} \geq 1$	t_{AA} , t_{AC}	$(\text{WS} + 0.75) \times T_C - 8.5$	—	20.7	ns
105	$\overline{\text{RD}}$ Assertion to Input Data Valid, $\text{WS} \geq 1$	t_{OE}	$(\text{WS} + 0.5) \times T_C - 8.5$	—	16.5	ns
106	$\overline{\text{RD}}$ Deassertion to Data Invalid (Data Hold Time)	t_{OHZ}	—	0.0	—	ns
107	Address Valid to $\overline{\text{WR}}$ Deassertion, $\text{WS} \geq 1$	t_{AW}	$(\text{WS} + 0.75) \times T_C - 4.4$	24.8	—	ns
108	Data Valid to $\overline{\text{WR}}$ Deassertion (Data setup time), $\text{WS} \geq 1$	t_{DS} (t_{DW})	$(\text{WS} - 0.25) \times T_C - 3.9$	8.6	—	ns

Table 2-10 SRAM Read and Write Access (Continued)

Num	Characteristics	Symbol	Expression	60 MHz		Unit
				Min	Max	
109	Data Hold Time from \overline{WR} Deassertion <ul style="list-style-type: none"> • $1 \leq WS \leq 3$ • $4 \leq WS \leq 7$ • $WS \geq 8$ 	t_{DH}	$0.25 \times T_C - 3.8$ $1.25 \times T_C - 3.8$ $2.25 \times T_C - 3.8$	0.4 17.0 33.7	— — —	ns
110	\overline{WR} Assertion to Data Active <ul style="list-style-type: none"> • $WS = 1$ • $2 \leq WS \leq 3$ • $WS \geq 4$ 	—	$0.75 \times T_C - 3.7$ $0.25 \times T_C - 3.7$ $-0.25 \times T_C - 3.7$	8.8 0.5 -7.9	— — —	ns
111	\overline{WR} Deassertion to Data High Impedance <ul style="list-style-type: none"> • $1 \leq WS \leq 3$ • $4 \leq WS \leq 7$ • $WS \geq 8$ 	—	$0.25 \times T_C + 0.6$ $1.25 \times T_C + 0.6$ $2.25 \times T_C + 0.6$	— — —	4.8 21.4 38.1	ns
112	Previous \overline{RD} Deassertion to Data Active (Write) <ul style="list-style-type: none"> • $1 \leq WS \leq 3$ • $4 \leq WS \leq 7$ • $WS \geq 8$ 	—	$1.25 \times T_C - 4.4$ $2.25 \times T_C - 4.4$ $3.25 \times T_C - 4.4$	16.4 33.1 49.8	— — —	ns
113	\overline{RD} Deassertion Time <ul style="list-style-type: none"> • $1 \leq WS \leq 3$ • $4 \leq WS \leq 7$ • $WS \geq 8$ 	—	$0.75 \times T_C - 4.4$ $1.75 \times T_C - 4.4$ $2.75 \times T_C - 4.4$	8.1 24.8 41.4	— — —	ns
114	\overline{WR} Deassertion Time <ul style="list-style-type: none"> • $WS = 1$ • $2 \leq WS \leq 3$ • $4 \leq WS \leq 7$ • $WS \geq 8$ 	—	$0.5 \times T_C - 3.1$ $T_C - 3.1$ $2.5 \times T_C - 3.1$ $3.5 \times T_C - 3.1$	5.2 13.6 38.6 55.2	— — — —	ns
115	Address Valid to \overline{RD} Assertion	—	$0.5 \times T_C - 4.0$	4.3	—	ns
116	\overline{RD} Assertion Pulse Width	—	$(WS + 0.25) \times T_C - 3.8$	17.0	—	ns
117	\overline{RD} Deassertion to Address Invalid <ul style="list-style-type: none"> • $1 \leq WS \leq 3$ • $4 \leq WS \leq 7$ • $WS \geq 8$ 	—	$0.25 \times T_C - 3.0$ $1.25 \times T_C - 3.0$ $2.25 \times T_C - 3.0$	1.2 17.8 34.5	— — —	ns

Specifications

AC Electrical Characteristics

Table 2-10 SRAM Read and Write Access (Continued)

Num	Characteristics	Symbol	Expression	60 MHz		Unit
				Min	Max	
Notes: 1. WS refers to the number of Wait States, as specified in the BCR. 2. The asynchronous delays specified in the expressions are valid for DSP56603-60. 3. The Address Trace (AT) pin is also active on accesses to internal program memory if the Address Trace Enable (ATE) bit (Bit 15) of the OMR is set. In this case, the \overline{MCS} , \overline{RD} , and \overline{WR} signals are deasserted and the data bus is tri-stated while the address bus is driven with the address of the internal access.						

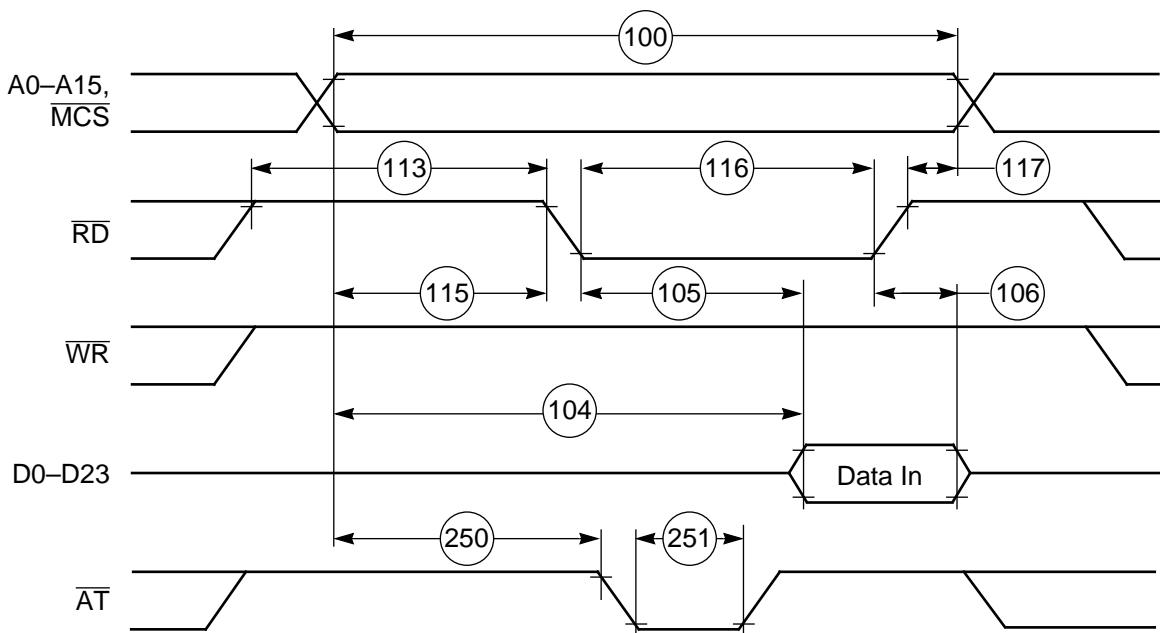

AA0375

Figure 2-11 SRAM Read Access

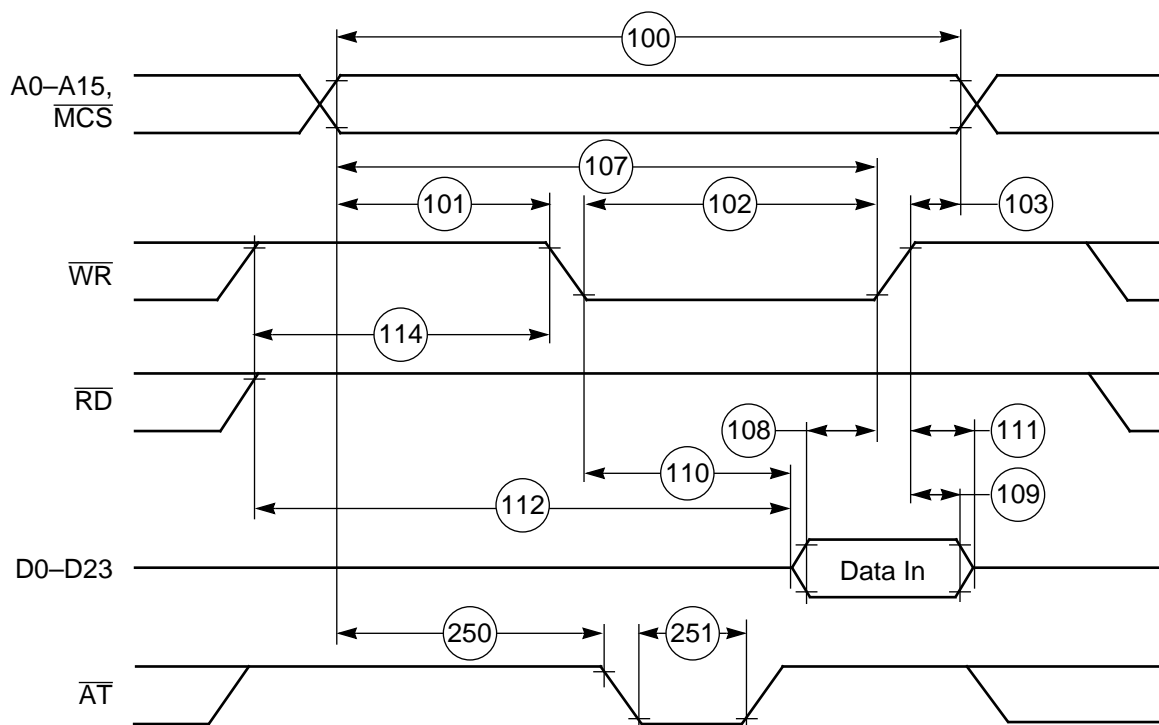

AA0376

Figure 2-12 SRAM Write Access

Table 2-11 External Bus Synchronous Timings (SRAM Access)

Num	Characteristics	Expression	60 MHz		Unit
			Min	Max	
198	CLKOUT Low to Address Valid and $\overline{\text{MCS}}$ Assertion	$0.25 \times T_C + 5.5$	—	9.7	ns
199	CLKOUT Low to Address Invalid and $\overline{\text{MCS}}$ Deassertion	$0.25 \times T_C$	4.2	—	ns
202	CLKOUT Low to Data Out Active ⁵	$0.25 \times T_C$	4.2	—	ns
203	CLKOUT Low to Data Out Valid	$0.25 \times T_C + 5.5$	—	9.7	ns
204	CLKOUT Low to Data Out Invalid	$0.25 \times T_C$	4.2	—	ns
205	CLKOUT Low to Data Out High Z ⁵	$0.25 \times T_C + 1.1$	—	5.3	ns
206	Data in valid to CLKOUT Low (Setup)	—	3.0	—	ns
207	CLKOUT Low to Data In Invalid (Hold)	—	0.0	—	ns

Specifications

AC Electrical Characteristics

Table 2-11 External Bus Synchronous Timings (SRAM Access) (Continued)

Num	Characteristics	Expression	60 MHz		Unit
			Min	Max	
208	CLKOUT Low to \overline{RD} Assertion <ul style="list-style-type: none"> • Minimum • Maximum 	$0.5 \times T_C + 1.1$	9.4	—	ns
		$0.5 \times T_C + 5.5$	—	13.8	ns
209	CLKOUT Low to \overline{RD} Deassertion	—	0.0	5.5	ns
210	CLKOUT Low to \overline{WR} Assertion ³ <ul style="list-style-type: none"> • $WS = 1$ • $2 \leq WS \leq 3$ • $WS \geq 4$ 	$0.5 \times T_C + 6.2$	10.1	14.5	ns
		—	1.8	6.2	
		$0.5 \times T_C + 6.2$	10.1	14.5	
211	CLKOUT Low to \overline{WR} Deassertion	—	0.0	4.9	ns

Notes:

1. WS is the number of Wait States specified in the BCR.
2. The asynchronous delays specified in the expressions are valid for DSP56603-60.
3. If $WS > 1$, \overline{WR} assertion refers to the next rising edge of CLKOUT.
4. "External Bus Synchronous Timings" should be used only for reference to the clock and **not** for relative timings.
5. These timings are periodically sampled and are not 100% tested.

Table 2-12 Address Trace Timings (Synchronous and Asynchronous)

Num	Characteristics	Expression	60 MHz		Unit
			Min	Max	
250	Address Setup Time to \overline{AT} Assertion	$0.5 \times T_C - 4.4$	3.9	—	ns
251	\overline{AT} Pulse Width	$0.5 \times T_C - 4.4$	3.9	—	ns
252	CLKOUT Low to \overline{AT} Assertion	$0.75 \times T_C + 5.5$	18.0	—	ns
253	CLKOUT Low to \overline{AT} Deassertion <ul style="list-style-type: none"> • Minimum • Maximum 	$0.25 \times T_C + 1.1$	5.3	—	ns
		$0.25 \times T_C + 5.5$	—	9.7	ns

Note:

1. The Address Trace (\overline{AT}) pin is also active on accesses to internal program memory if the Address Trace Enable (ATE) bit (Bit 15) of the OMR is set. In this case, the \overline{MCS} , \overline{RD} , and \overline{WR} signals are deasserted and the data bus is tri-stated while the address bus is driven with the address of the internal access.

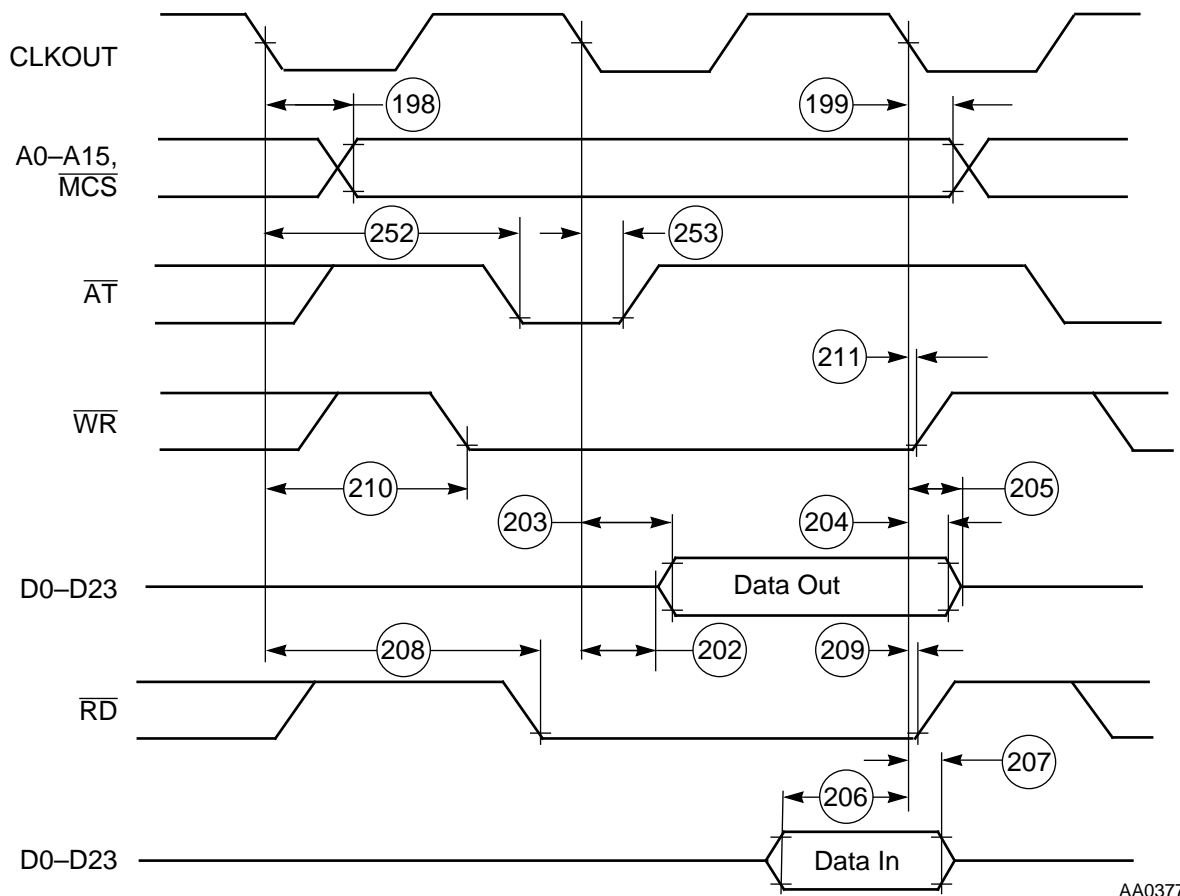

AA0377

Figure 2-13 Synchronous Bus Timings SRAM 1 WS

AC Electrical Characteristics—Host Interface Timing

($V_{CC} = 3.0 \text{ V} \pm 0.3 \text{ V}$; $T_A = -40^\circ \text{ to } 85^\circ \text{C}$, $C_L = 50 \text{ pF} + 2 \text{ TTL Loads}$)

Host Port Usage Considerations

Careful synchronization is required when reading multi-bit registers that are written by another asynchronous system. This is a common problem when two asynchronous systems are connected. The situation exists in the Host port. The considerations for proper operation are discussed below.

1. **Asynchronous Reading of Receive Byte Registers**—When reading the receive byte registers, RXH or RXL, the Host programmer should use

Specifications

AC Electrical Characteristics

interrupts or poll the RXDF flag, which indicates that data is available. This assures that the data in the receive byte registers will be valid.

2. **Overwriting Transmit Byte Registers**—The Host programmer should not write to the transmit byte registers, TXH or TXL, unless the TXDE bit is set indicating that the transmit byte registers are empty. This guarantees that the transmit byte registers can transfer valid data to the HRX register.
3. **Overwriting the Host Vector**—The Host Vector register should be changed only when the Host Command bit (HC) is clear. This guarantees that the DSP56603 interrupt control logic can receive a stable vector.

Table 2-13 Host Interface Timing

Num	Characteristic	Symbol	Expression	60 MHz		Unit
				Min	Max	
300	Access Cycle Time	—	$4 \times T_C$	66.7	—	ns
301	Read Data Strobe Assertion Width ⁵ $\overline{\text{HACK}}$ Assertion Width	—	$T_C + 16.5$	33.2	—	ns
302	Read Data Strobe Deassertion Width ⁵ $\overline{\text{HACK}}$ Deassertion Width	—	—	16.5	—	ns
303	Read Data Strobe Deassertion Width between two consecutive “Last Data Register” Reads, two consecutive CVR Reads, two consecutive ICR Reads, or two consecutive ISR Reads ^{3, 5, 8}	—	$2.5 \times T_C + 11.0$	52.7	—	ns
304	Write Data Strobe Assertion Width ⁶	—	—	22.0	—	ns
305	Write Data Strobe Deassertion Width ⁶	—	$2.5 \times T_C + 11.0$	52.7	—	ns
306	$\overline{\text{HAS}}$ Assertion Width	—	—	16.5	—	ns
307	$\overline{\text{HAS}}$ Deassertion to Data Strobe Assertion ⁴	—	—	0	—	ns
308	Host Data Input Setup Time before Write Data Strobe Deassertion ⁶	—	—	16.5	—	ns
309	Host Data Input Hold Time after Write Data Strobe Deassertion ⁶	—	—	5.5	—	ns
310	Read Data Strobe Assertion to Output Data Active from High Impedance ^{5, 10} $\overline{\text{HACK}}$ Assertion to Output Data Active from High Impedance ¹⁰	—	—	5.0	—	ns
311	Read Data Strobe Assertion to Output Data Valid ⁵ $\overline{\text{HACK}}$ Assertion to Output Data Valid	—	—	—	33.0	ns

Table 2-13 Host Interface Timing (Continued)

Num	Characteristic	Symbol	Expression	60 MHz		Unit
				Min	Max	
312	Read Data Strobe Deassertion to Output Data High Impedance ^{5, 10} $\overline{\text{HACK}}$ Deassertion to Output Data High Impedance ¹⁰	—	—	—	16.5	ns
313	Output Data Hold Time after Read Data Strobe Deassertion ⁵ Output Data Hold Time after $\overline{\text{HACK}}$ Deassertion	—	—	5.5	—	ns
314	$\overline{\text{HCS}}$ Assertion to Read Data Strobe Deassertion	—	$T_C + 16.5$	33.2	—	ns
315	$\overline{\text{HCS}}$ Assertion to Write Data Strobe Deassertion ⁶	—	—	16.5	—	ns
316	$\overline{\text{HCS}}$ Assertion to Output Data Valid	—	—	—	27.5	ns
317	$\overline{\text{HCS}}$ Hold Time after Data Strobe Deassertion ^{4, 6}	—	—	0	—	ns
318	Address (HAD0–HAD7) Setup Time before $\overline{\text{HAS}}$ Deassertion (HMUX = 1)	—	—	7.7	—	ns
319	Address (HAD0–HAD7) Hold Time after $\overline{\text{HAS}}$ Deassertion (HMUX = 1)	—	—	5.5	—	ns
320	HA8–HA10 (HMUX = 1), HA0–HA2 (HMUX = 0), HRW Setup Time before Data Strobe Assertion ⁴	—	—	11.0	—	ns
321	HA8–HA10 (HMUX = 1), HA0–HA2 (HMUX = 0), HRW Hold Time after Data Strobe Deassertion ⁴	—	—	5.5	—	ns
322	Delay from Read Data Strobe Deassertion to Host Request Assertion for “Last Data Register” Read ^{5, 7, 8, 9}	—	$2 \times T_C + 27.5$	60.8	—	ns
323	Delay from Write Data Strobe Deassertion to Host Request Assertion for “Last Data Register” Write ^{6, 7, 8, 9}	—	$1.5 \times T_C + 27.5$	52.5	—	ns
324	Delay from Data Strobe Assertion to Host Request Deassertion for “Last Data Register” Read or Write (HROD = 0) ^{4, 7, 8}	—	—	—	27.5	ns
325	Delay from Data Strobe Assertion to Host Request Deassertion for “Last Data Register” Read or Write (HROD = 1, Open drain host request) ^{4, 7, 8, 9}	—	—	—	300.0	ns

Specifications

AC Electrical Characteristics

Table 2-13 Host Interface Timing (Continued)

Num	Characteristic	Symbol	Expression	60 MHz		Unit
				Min	Max	
Notes:						
1.	See Host Port Usage Considerations on page 2-19.					
2.	In the following timing diagrams (Figure 2-14 through Figure 2-18), the controls pins are drawn as active low. Pin polarity is programmable.					
3.	This timing must be adhered to only if two consecutive reads from one of these registers are executed.					
4.	The Data Strobe is HRD or HWR in the Dual Data Strobe mode, HDS in the Single Data Strobe mode.					
5.	The Read Data Strobe is HRD in the Dual Data Strobe mode, HDS in the Single Data Strobe mode.					
6.	The Write Data Strobe is HWR in the Dual Data Strobe mode, HDS in the Single Data Strobe mode.					
7.	The Host Request is HREQ in the Single Host Request mode, HRRQ and HTRQ in the Double Host Request mode.					
8.	The “Last Data Register” is the register at address \$7, which is the last location to be read or written in data transfers.					
9.	In this calculation, the host request signal is pulled up by a 4.7 kΩ resistor in the Open Drain mode.					
10.	These timings are periodically sampled and are not 100% tested.					

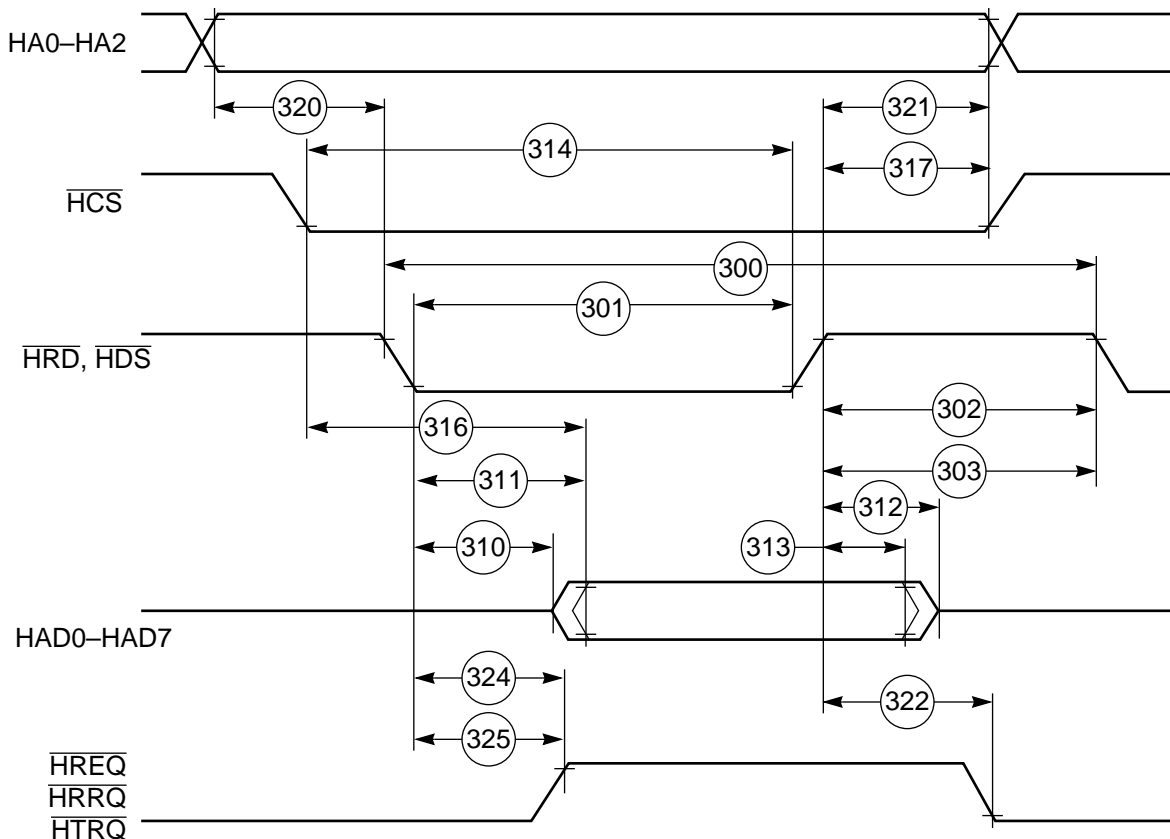

AA0378

Figure 2-14 Read Timing Diagram—Non Multiplexed Bus

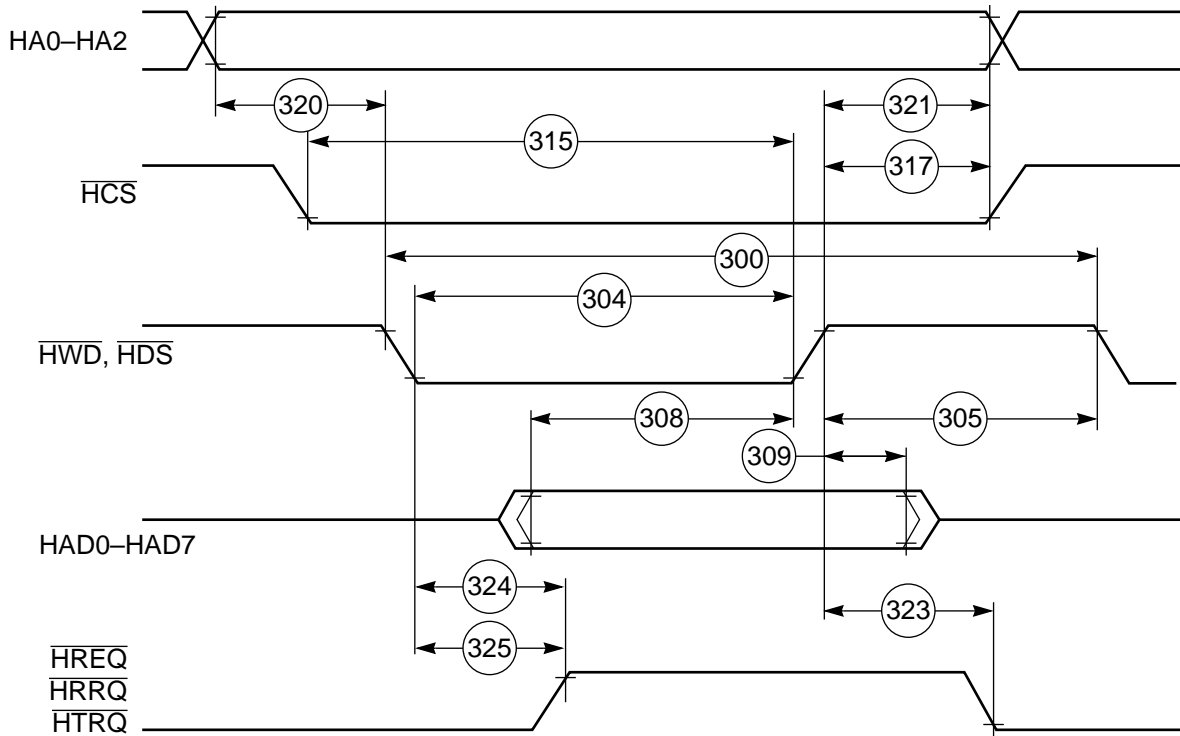

AA0379

Figure 2-15 Write Timing Diagram—Non Multiplexed Bus

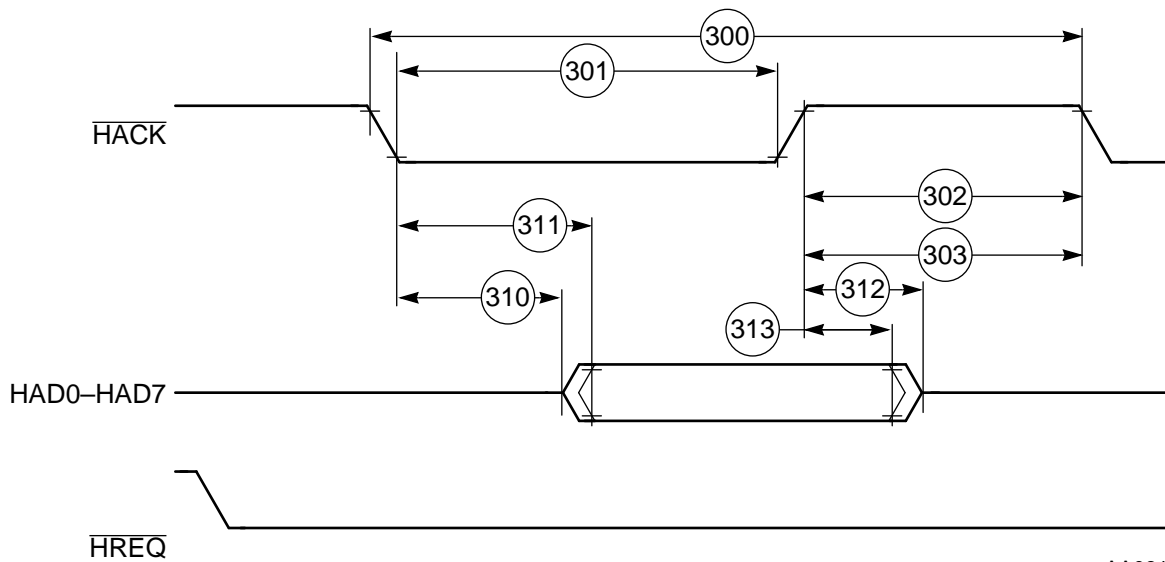

AA0815

Figure 2-16 Host Interrupt Vector Register (IVR) Read Timing Diagram

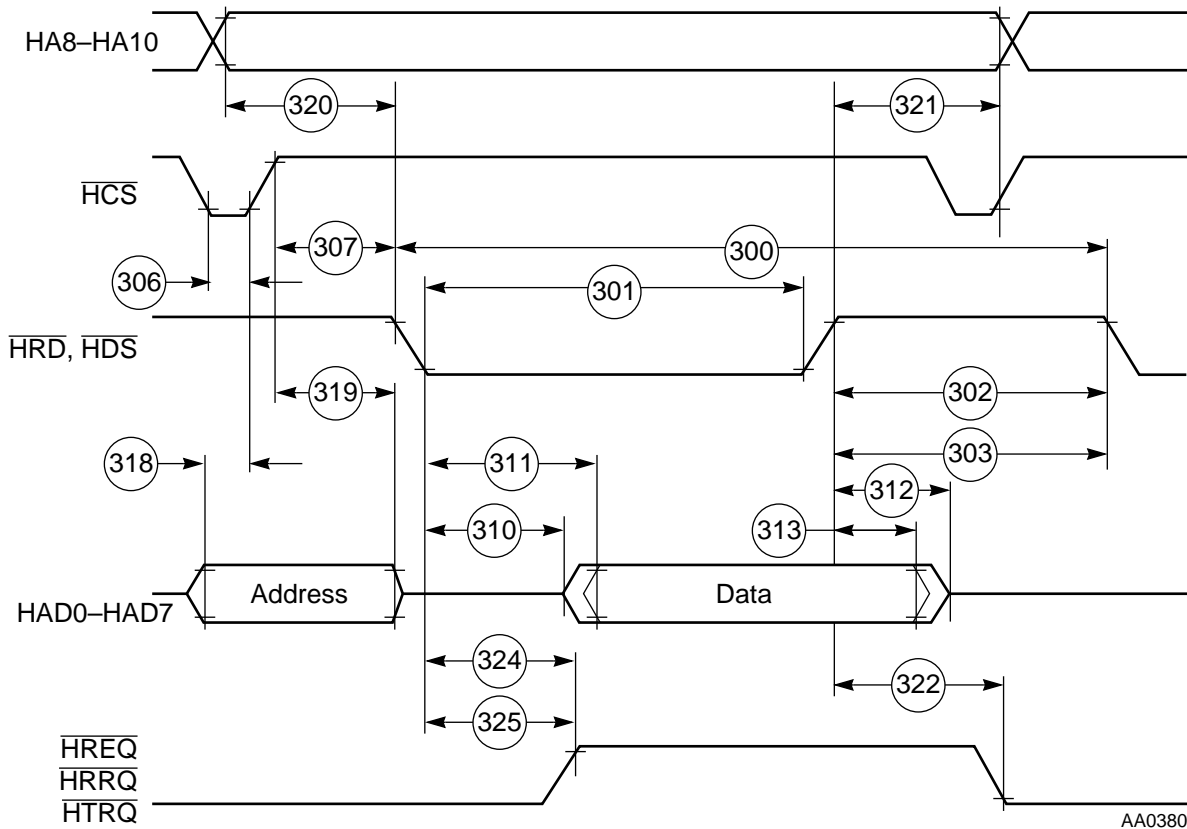

AA0380

Figure 2-17 Read Timing Diagram—Multiplexed Bus

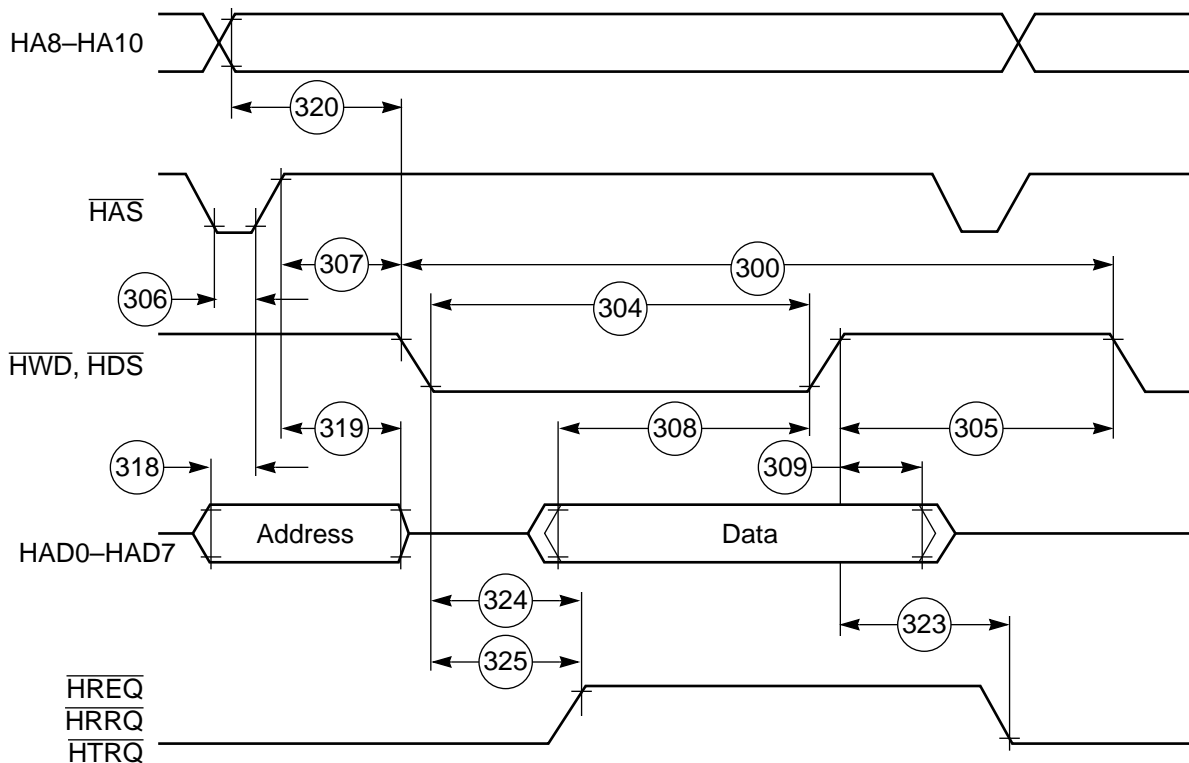

AA0381

Figure 2-18 Write Timing Diagram—Multiplexed Bus

AC Electrical Characteristics—SSI0/SSI1 Timing

($V_{CC} = 3.0\text{ V} \pm 0.3\text{ V}$; $T_A = -40^\circ$ to 85°C , $C_L = 50\text{ pF} + 2\text{ TTL Loads}$)

Table 2-14 Key to Table 2-14 SSI Timing

Case	Meaning
t_{SSICC}	SSI Clock Cycle Time
TXC	Transmit Clock (on SCK Pin)
RXC	Receive Clock (on SC0 or SCK Pin)
FST	Transmit Frame Sync (on SC2 Pin)
FSR	Receive Frame Sync (SC1 or SC2 Pin)
i ck	Internal Clock

Specifications

AC Electrical Characteristics

Table 2-14 Key to Table 2-14 SSI Timing (Continued)

Case	Meaning
x ck	External Clock
i ck a	Internal Clock, Asynchronous Mode (Asynchronous implies that TXC and RXC are two different clocks)
i ck s	Internal Clock, Synchronous Mode (Synchronous implies that TXC and RXC are the same clock)
bl	Bit Length
wl	Word Length
wr	Word Length Relative

Table 2-15 SSI Timing

Num	Characteristics	Symbol	Expression	60 MHz		Case	Unit
				Min	Max		
430	Clock Cycle ¹	t_{SSICC}	$4 \times T_C$ $3 \times T_C$	66.7 50.0	— —	i ck x ck	ns ns
431	Clock High Period • for internal clock • for external clock	—	$2 \times T_C - 12.2$ $1.5 \times T_C$	21.1 25.0	— —	i ck x ck	ns ns
432	Clock Low Period • for internal clock • for external clock	—	$2 \times T_C - 12.2$ $1.5 \times T_C$	21.1 25.0	— —	i ck x ck	ns ns
433	RXC Rising Edge to FSR Out (bl) High	—	—	— —	45.1 26.8	x ck i ck a	ns ns
434	RXC Rising Edge to FSR Out (bl) Low	—	—	— —	45.1 26.8	x ck i ck a	ns ns
435	RXC Rising Edge to FSR Out (wr) High ³	—	—	— —	47.6 29.3	x ck i ck a	ns ns
436	RXC Rising Edge to FSR Out (wr) Low ³	—	—	— —	47.6 29.3	x ck i ck a	ns ns
437	RXC Rising Edge to FSR Out (wl) High	—	—	— —	45.9 25.6	x ck i ck a	ns ns
438	RXC Rising Edge to FSR Out (wl) Low	—	—	— —	45.1 26.8	x ck i ck a	ns ns

Table 2-15 SSI Timing (Continued)

Num	Characteristics	Symbol	Expression	60 MHz		Case	Unit
				Min	Max		
439	Data In Setup Time before RXC (SCK in Synchronous Mode) Falling Edge	—	—	0.0 23.2	— —	x ck i ck	ns ns
440	Data In Hold Time after RXC Falling Edge	—	—	6.1 3.6	— —	x ck i ck	ns ns
441	FSR Input (bl, wr) High before RXC Falling Edge ³	—	—	28.0 1.2	— —	x ck i ck a	ns ns
442	FSR Input (wl) High before RXC Falling Edge	—	—	28.0 1.2	— —	x ck i ck a	ns ns
443	FSR Input Hold Time after RXC Falling Edge	—	—	3.6 0.0	— —	x ck i ck a	ns ns
444	Flags Input Setup before RXC Falling Edge	—	—	0.0 23.2	— —	x ck i ck s	ns ns
445	Flags Input Hold Time after RXC Falling Edge	—	—	7.3 0.0	— —	x ck i ck s	ns ns
446	TXC Rising Edge to FST Out (bl) High	—	—	— —	35.4 18.3	x ck i ck	ns ns
447	TXC Rising Edge to FST Out (bl) Low	—	—	— —	37.8 20.7	x ck i ck	ns ns
448	TXC Rising Edge to FST Out (wr) High ³	—	—	— —	37.8 20.7	x ck i ck	ns ns
449	TXC Rising Edge to FST Out (wr) Low ³	—	—	— —	40.3 23.2	x ck i ck	ns ns
450	TXC Rising Edge to FST Out (wl) High	—	—	— —	36.6 19.5	x ck i ck	ns ns
451	TXC Rising Edge to FST Out (wl) Low	—	—	— —	37.8 20.7	x ck i ck	ns ns
452	TXC Rising Edge to Data Out Enable from High Impedance	—	—	— —	37.8 20.7	x ck i ck	ns ns
454	TXC Rising Edge to Data Out Valid	—	$35 + 0.5 \times T_C$	— —	52.8 25.6	x ck i ck	ns ns
455	TXC Rising Edge to Data Out High Impedance ²	—	—	— —	37.8 19.5	x ck i ck	ns ns
457	FST Input (bl, wr) Setup Time before TXC Falling Edge ³	—	—	2.0 21.0	— —	x ck i ck	ns ns

Specifications

AC Electrical Characteristics

Table 2-15 SSI Timing (Continued)

Num	Characteristics	Symbol	Expression	60 MHz		Case	Unit
				Min	Max		
458	FST Input (wl) to Data Out Enable from High Impedance ²	—	—	—	32.9	x ck i ck	ns
460	FST Input (wl) Setup Time before TXC Falling Edge	—	—	2.0 21.0	— —	x ck i ck	ns ns
461	FST Input Hold Time After TXC Falling Edge	—	—	4.0 0.0	— —	x ck i ck	ns ns
462	Flag Output Valid After TXC Rising Edge	—	—	— —	39.0 22.0	x ck i ck	ns ns

Notes:

1. For internal clock, External Clock Cycle is defined by I_{cyc} and SSI control register.
2. These timings are periodically sampled and are not 100% tested.
3. The Word Relative Frame Sync signal is related to the clock signal as the Bit Length Frame Sync signal, but has a period that extends from one serial clock pulse prior to the first bit clock pulse (the same as the Bit Length Frame Sync signal) until one serial clock pulse prior to the last bit clock pulse of the first word in the frame.

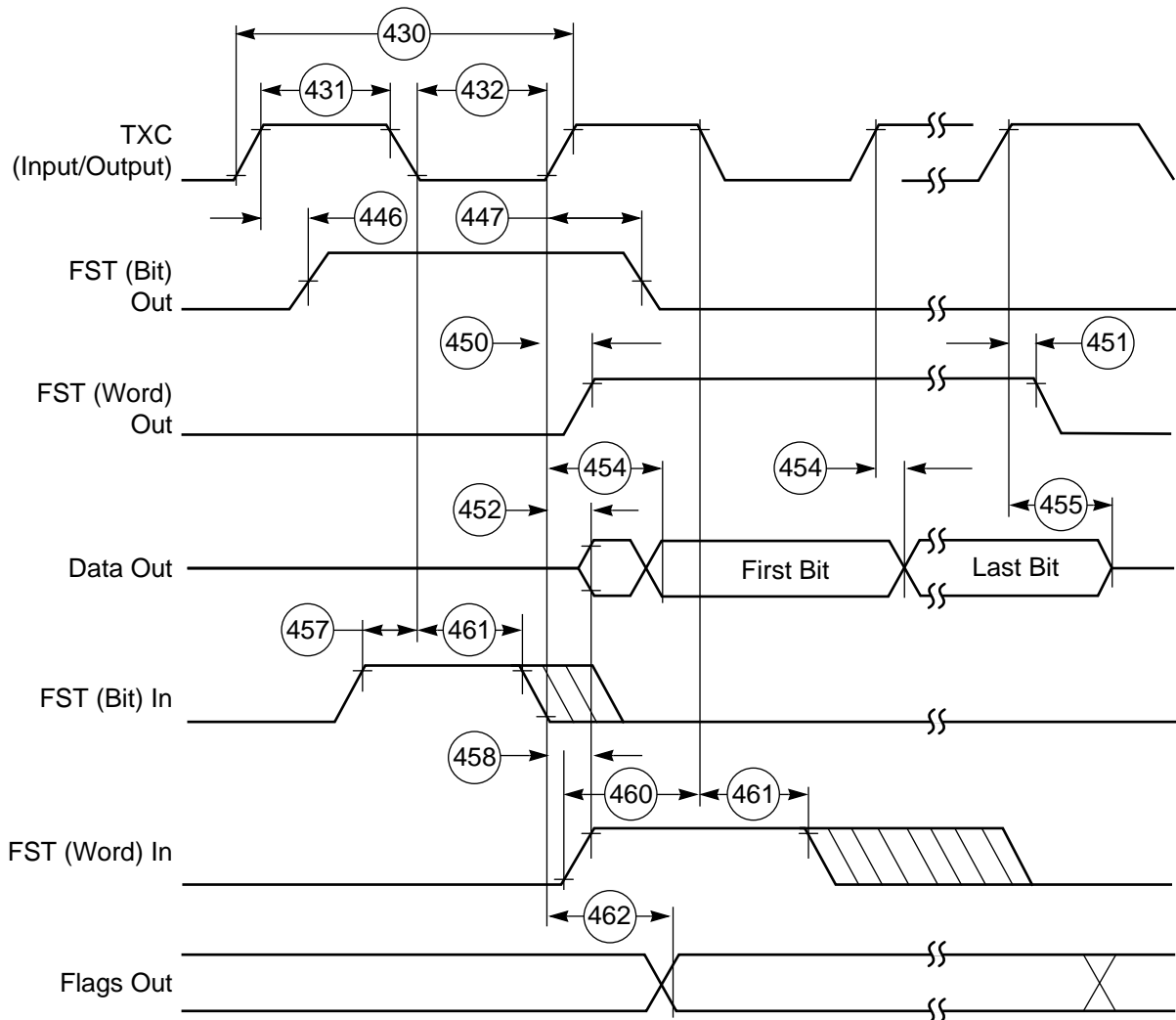

NOTE: In the Network mode, output flag transitions can occur at the start of each time slot within the frame. In the Normal mode, the output flag state is asserted for the entire frame period.

AA0382

Figure 2-19 SSI Transmitter Timing

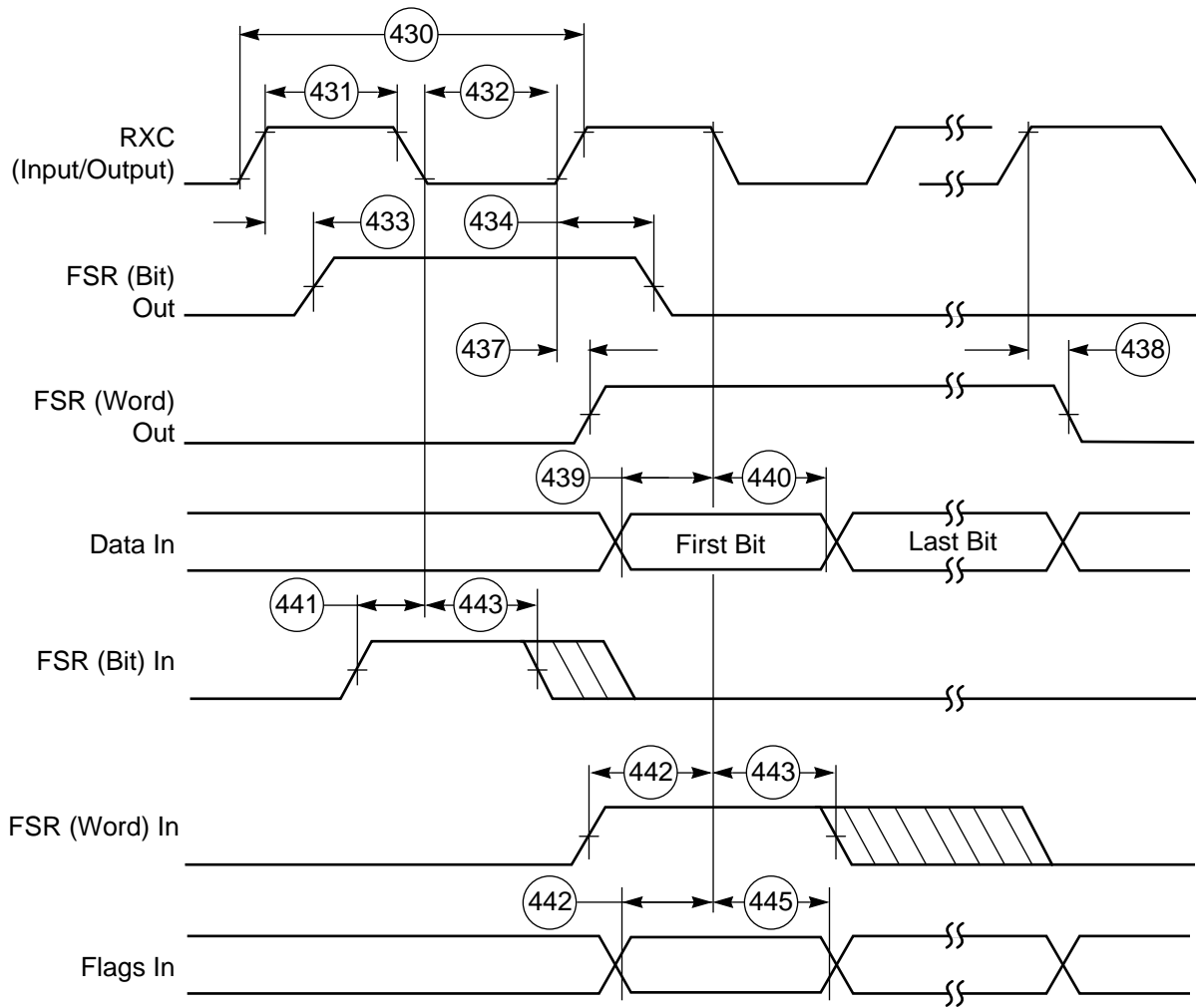

AA0383

Figure 2-20 SSI Receiver Timing

AC Electrical Characteristics—Timer Timing

($V_{CC} = 3.0 \text{ V} \pm 0.3 \text{ V}$; $T_A = -40^\circ$ to 85°C , $C_L = 50 \text{ pF} + 2 \text{ TTL Loads}$)

Table 2-16 Timer Timing

Num	Characteristics	Symbol	Expression	60 MHz		Unit
				Min	Max	
480	TIO Low	—	$2 \times T_C + 2.4$	35.7	—	ns
481	TIO High	—	$2 \times T_C + 2.4$	35.7	—	ns
482	Timer Setup Time from TIO (Input) Assertion to CLKOUT Rising Edge	—	T_C	11.0	16.7	ns
483	Synchronous Timer Delay Time from CLKOUT Rising Edge to the External Memory Access Address Out Valid, caused by first interrupt instruction execution	—	$10.25 \times T_C + 1.2$	172.0	—	ns
484	CLKOUT Rising Edge to TIO (output) Assertion	—	$0.5 \times T_C + 4.3$ $0.5 \times T_C + 24.2$	12.6	32.5	ns
485	CLKOUT Rising Edge to TIO (output) Deassertion	—	$0.5 \times T_C + 4.3$ $0.5 \times T_C + 24.2$	12.6	32.5	ns

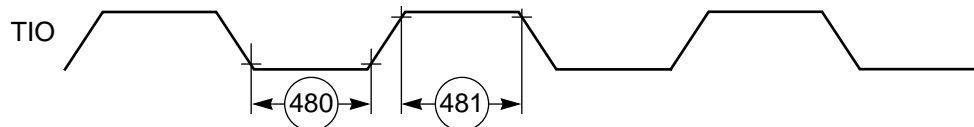

AA0384

Figure 2-21 TIO Timer Event Input Restrictions

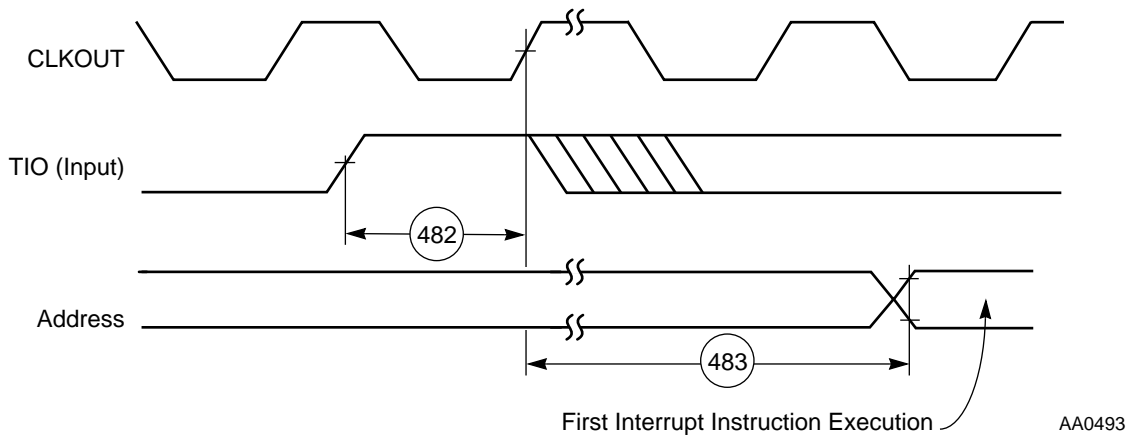

Figure 2-22 Timer Interrupt Generation

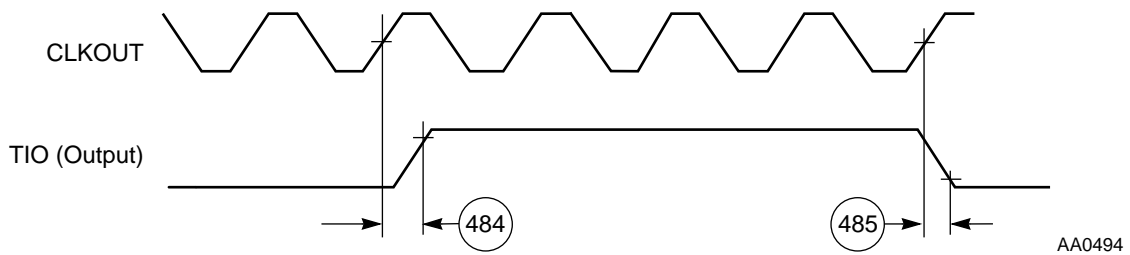

Figure 2-23 External Pulse Generation

AC Electrical Characteristics—GPIO Timing

($V_{CC} = 3.0\text{ V} \pm 0.3\text{ V}$; $T_A = -40^\circ$ to 85°C , $C_L = 50\text{ pF} + 2\text{ TTL Loads}$)

Note: GPIO timings apply to all GPIO signals used on the dedicated GPIO pins, HI08 pins, SSI pins, and Timer pins.

Table 2-17 GPIO Timing

Num	Characteristics	Symbol	Expression	60 MHz		Unit
				Min	Max	
490	CLKOUT Edge to GPIO Output Valid (GPIO Out Delay Time)	—	—	—	37.8	ns
491	CLKOUT Edge to GPIO Output Invalid (GPIO Out Hold Time)	—	—	3.6	—	ns
492	GPIO In Valid to CLKOUT Edge (GPIO In Setup Time)	—	—	14.6	—	ns
493	CLKOUT Edge to GPIO Input Invalid (GPIO In Hold Time)	—	—	0.0	—	ns
494	Fetch to CLKOUT Edge before GPIO Change	—	$6.75 \times T_C$	112.5	—	ns

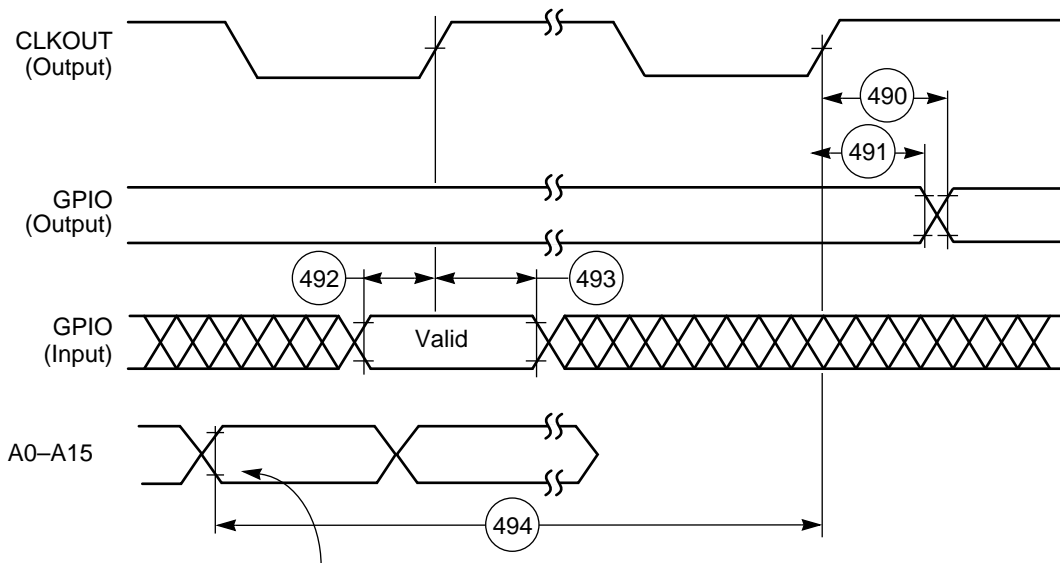

fetch the instruction MOVE X0,X:(R0); X0 contains the new value of GPIO and R0 contains the address of GPIO data register

AA0384

Figure 2-24 GPIO Timing

AC Electrical Characteristics—JTAG Timing

($V_{CC} = 3.0\text{ V} \pm 0.3\text{ V}$; $T_A = -40^\circ$ to 85°C , $C_L = 50\text{ pF} + 2\text{ TTL Loads}$)

Table 2-18 JTAG Timing

Num	Characteristics	Symbol	Expression	60 MHz		Unit
				Min	Max	
500	TCK Frequency of Operation	—	$1/(3 \times T_C)$	0.0	22.0	MHz
501	TCK Cycle Time in Crystal Mode	—	—	45.0	—	ns
502	TCK Clock Pulse Width Measured at 1.5 V	—	—	20.0	—	ns
503	TCK Rise and Fall Times	—	—	0.0	3.0	ns
504	Boundary Scan Input Data Setup Time	—	—	5.0	—	ns
505	Boundary Scan Input Data Hold Time	—	—	24.0	—	ns
506	TCK Low to Output Data Valid	—	—	0.0	40.0	ns
507	TCK Low to Output High Impedance ¹	—	—	0.0	40.0	ns
508	TMS, TDI Data Setup Time	—	—	5.0	—	ns
509	TMS, TDI Data Hold Time	—	—	25.0	—	ns
510	TCK Low to TDO Data Valid	—	—	0.0	44.0	ns
511	TCK Low to TDO High Impedance ¹	—	—	0.0	44.0	ns
512	$\overline{\text{TRST}}$ Assert Time	—	—	100.0	—	ns
513	$\overline{\text{TRST}}$ Setup Time to TCK Low	—	—	40.0	—	ns
514	$\overline{\text{DE}}$ assertion time in order to enter debug mode	—	$1.5 \times T_C + 11.0$	36.0	—	ns
515	Response time when DSP56603 is executing NOP instructions from internal memory	—	$5.5 \times T_C + 33.0$	—	124.7	ns
516	Debug acknowledge assertion time	—	$3 \times T_C + 11.0$	61.0	—	ns

Note: 1. These timings are periodically sampled and are not 100% tested.

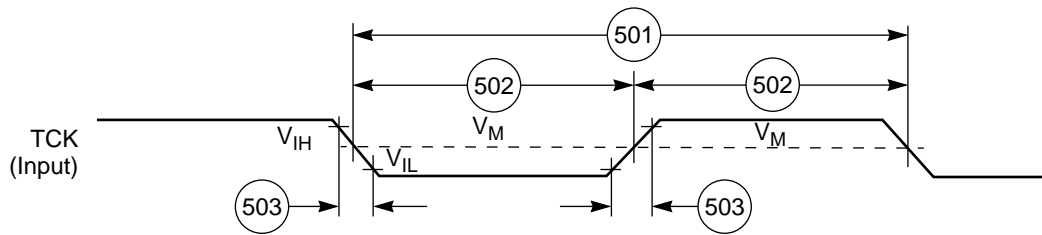

AA0496

Figure 2-25 Test Clock Input Timing Diagram

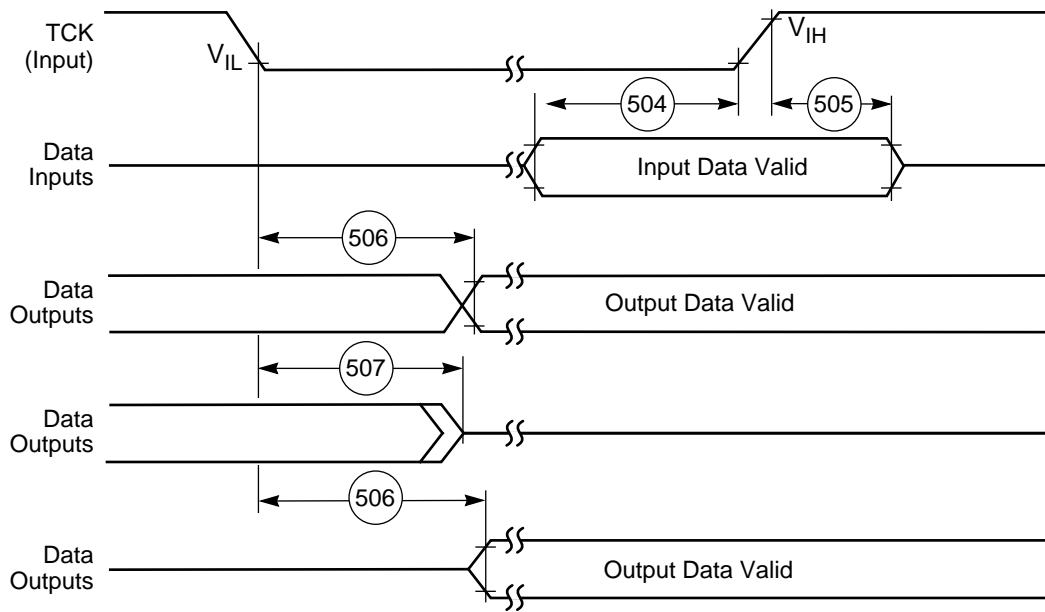

AA0497

Figure 2-26 Boundary Scan (JTAG) Timing Diagram

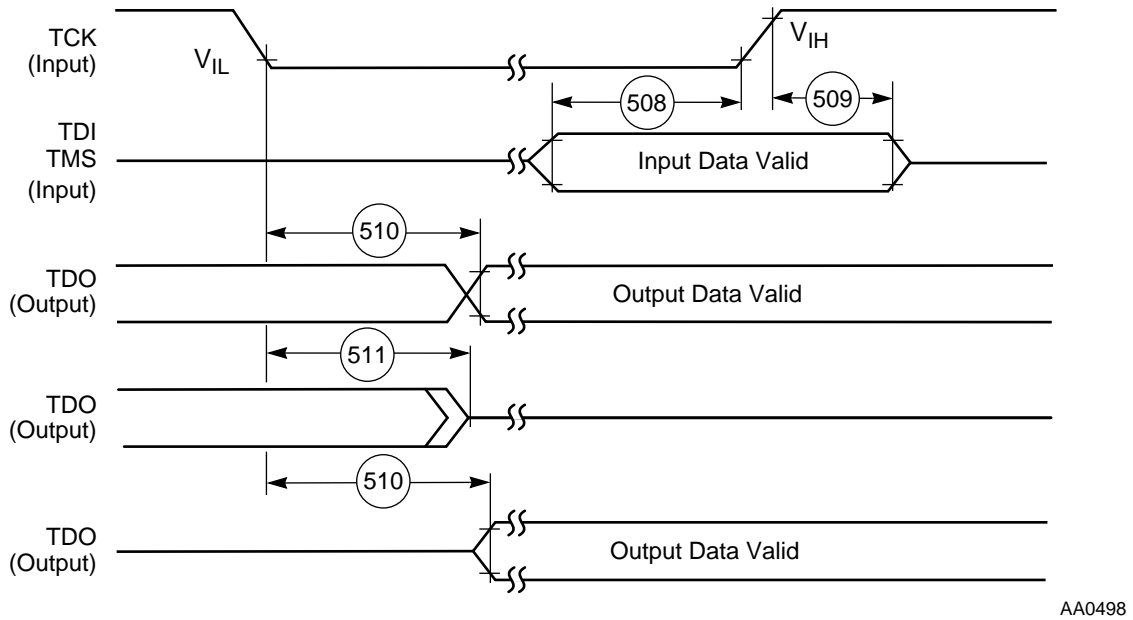

Figure 2-27 Test Access Port Timing Diagram

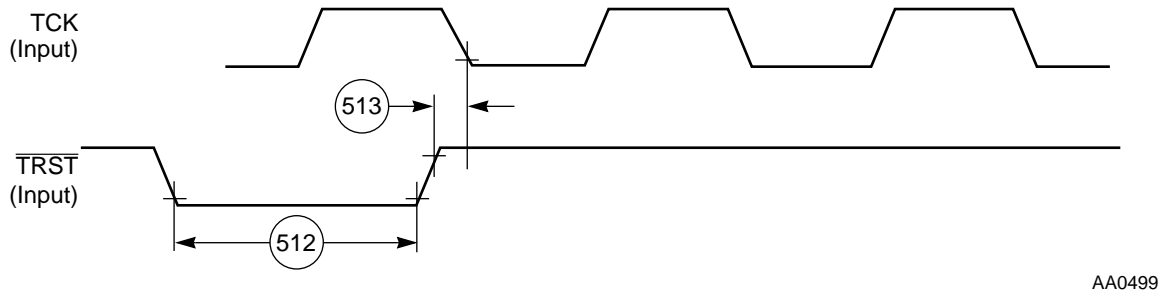

Figure 2-28 $\overline{\text{TRST}}$ Timing Diagram

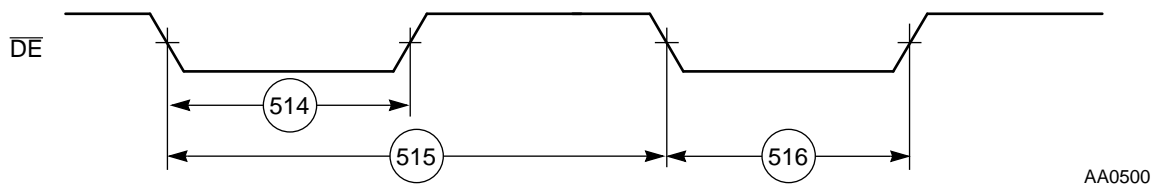

Figure 2-29 OnCE—Debug Request

PACKAGING

PACKAGE AND PIN-OUT INFORMATION

This section contains package and pin-out information for the 144-pin Thin Quad Flat Pack (TQFP) configuration of the DSP56603. **Table 3-1** on page 3-4 identifies the DSP56603 pins on the package in numeric order. **Table 3-2** on page 3-5 identifies the DSP56603 pins by name order. **Table 3-4** on page 3-11 groups power and ground leads. Mechanical drawings of the package are presented in **Figure 3-3** on page 3-12.

Complete mechanical information regarding DSP56603 packaging is available by facsimile through Motorola's Mfax™ system. Call (602) 244-6609 to obtain instructions for using this system. The automated system requests the following information:

- The receiving fax telephone number including area code or country code
- The caller's Personal Identification Number (PIN)

Note: For first time callers, the system provides instructions for setting up a PIN, which requires entry of a name and telephone number.

- The type of information requested:
 - Instructions for using the system
 - A literature order form
 - Specific part technical information or data sheets
 - Other information described by the system messages

A total of three documents may be ordered per call.

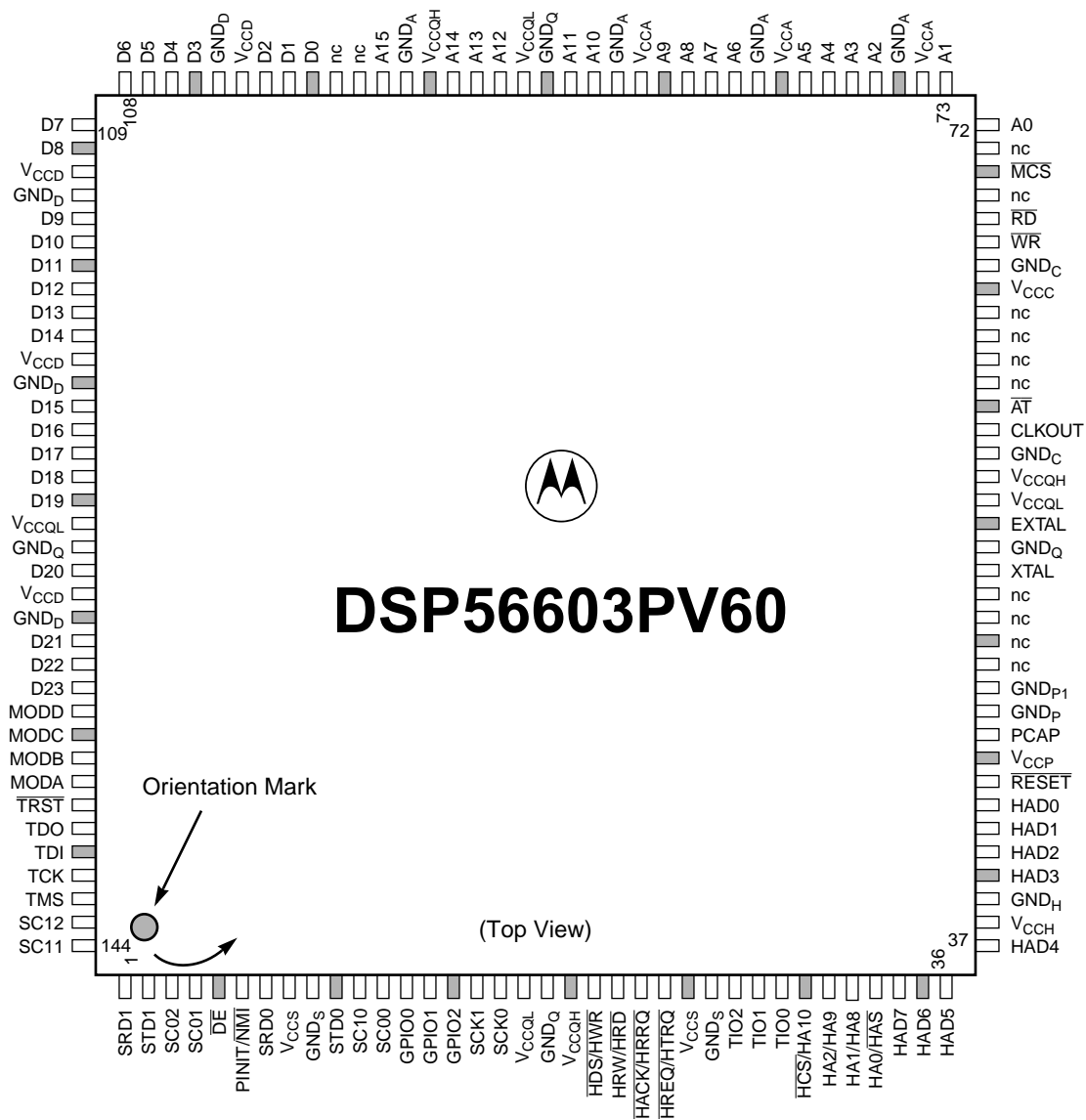

- Notes:
1. Pins marked "nc" are no connection pins that are reserved for possible future enhancements. Do not connect these pins to any power, ground, signal traces, or vias.
 2. To simplify locating the pins, each fifth pin is shaded in the illustration.

Figure 3-1 Top View of DSP56603 144-pin Plastic Thin Quad Flat Package

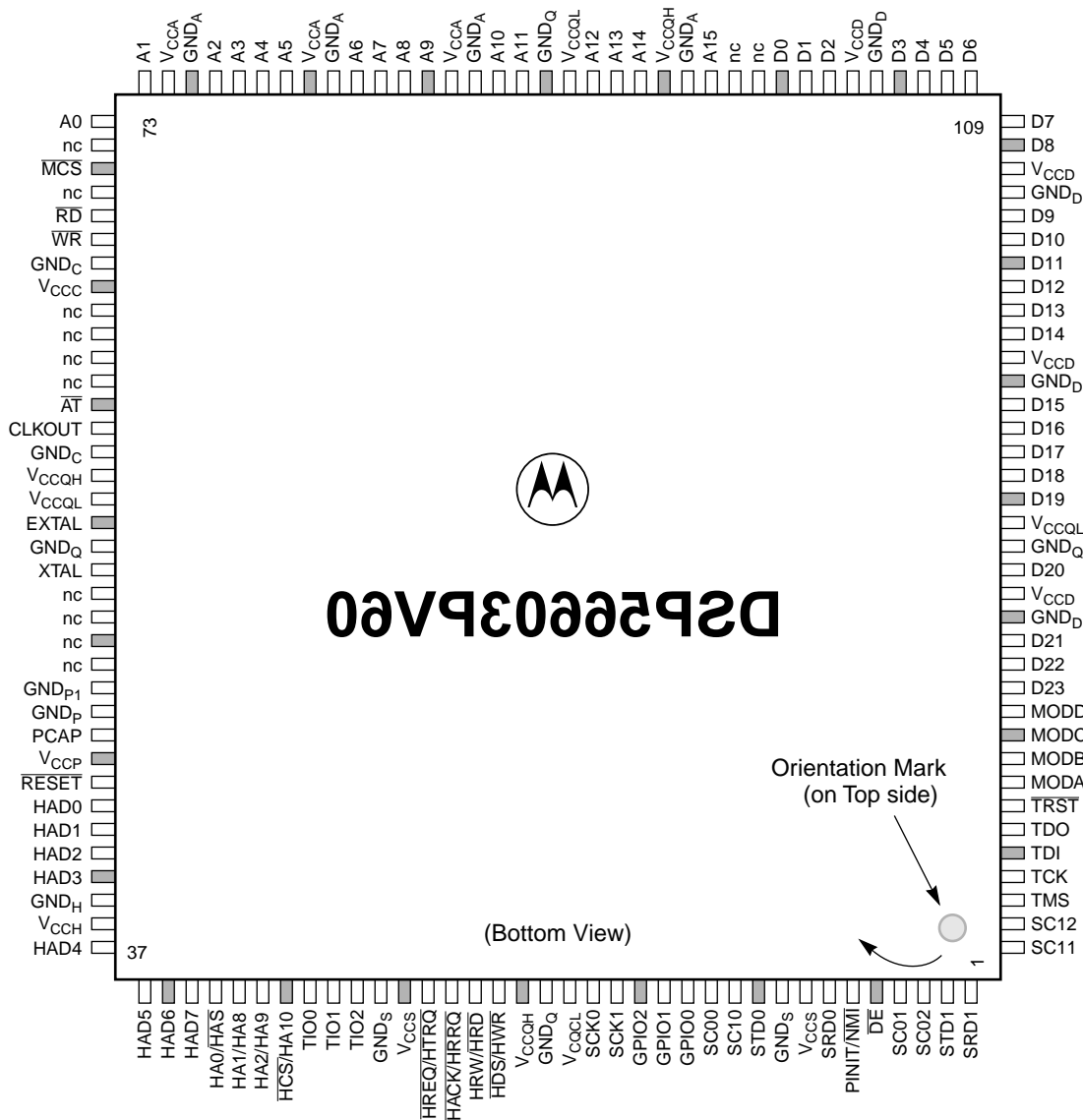

- Notes:
1. Pins marked "nc" are no connection pins that are reserved for possible future enhancements. Do not connect these pins to any power, ground, signal traces, or vias.
 2. To simplify locating the pins, each fifth pin is shaded in the illustration.

Figure 3-2 Bottom View of DSP56603 144-pin Plastic Thin Quad Flat Package

Packaging

Package and Pin-Out Information

Table 3-1 DSP56603 144-pin TQFP Pin Identification by Pin Number

UP		RIGHT		DOWN		LEFT	
Pin #	Name	Pin #	Name	Pin #	Name	Pin #	Name
144	SC11	108	D6	72	A0	36	HAD5
143	SC12	107	D5	71	nc	35	HAD6
142	TMS	106	D4	70	\overline{MCS}	34	HAD7
141	TCK	105	D3	69	nc	33	HA0/ \overline{HAS}
140	TDI	104	GND _D	68	\overline{RD}	32	HA1/HA8
139	TDO	103	V _{CCD}	67	\overline{WR}	31	HA2/HA9
138	\overline{TRST}	102	D2	66	GND _C	30	\overline{HCS} /HA10
137	MODA/ \overline{IRQA}	101	D1	65	V _{CCC}	29	TIO0
136	MODB/ \overline{IRQB}	100	D0	64	nc	28	TIO1
135	MODC/ \overline{IRQC}	99	nc	63	nc	27	TIO2
134	MODD/ \overline{IRQD}	98	nc	62	nc	26	GND _S
133	D23	97	A15	61	nc	25	V _{CCS}
132	D22	96	GND _A	60	\overline{AT}	24	\overline{HREQ} / \overline{HTRQ}
131	D21	95	V _{CCCH}	59	CLKOUT	23	\overline{HACK} / \overline{HRRQ}
130	GND _D	94	A14	58	GND _C	22	HRW/ \overline{HRD}
129	V _{CCD}	93	A13	57	V _{CCQH}	21	\overline{HDS} / \overline{HWR}
128	D20	92	A12	56	V _{CCLQ}	20	V _{CCQH}
127	GND _Q	91	V _{CCQL}	55	EXTAL	19	GND _Q
126	V _{CCQL}	90	GND _Q	54	GND _Q	18	V _{CCQL}
125	D19	89	A11	53	XTAL	17	SCK0
124	D18	88	A10	52	nc	16	SCK1
123	D17	87	GND _A	51	nc	15	GPIO2
122	D16	86	V _{CCA}	50	nc	14	GPIO1
121	D15	85	A9	49	nc	13	GPIO0
120	GND _D	84	A8	48	GND _{P1}	12	SC00
119	V _{CCD}	83	A7	47	GND _P	11	SC10
118	D14	82	A6	46	PCAP	10	STD0
117	D13	81	GND _A	45	V _{CCP}	9	GND _S
116	D12	80	V _{CCA}	44	\overline{RESET}	8	V _{CCS}
115	D11	79	A5	43	HAD0	7	SRD0
114	D10	78	A4	42	HAD1	6	PINIT/ \overline{NMI}
113	D9	77	A3	41	HAD2	5	\overline{DE}
112	GND _D	76	A2	40	HAD3	4	SC01
111	V _{CCD}	75	GND _A	39	GND _H	3	SC02
110	D8	74	V _{CCA}	38	V _{CCH}	2	STD1
109	D7	73	A1	37	HAD4	1	SRD1

Note: Pins marked “nc” in Table 3-1 are not connected.

Table 3-2 DSP56603 144-pin TQFP Pin Identification by Pin Name

Name	Pin #	Functional Group	Name	Pin #	Functional Group
A0	72	Port A Address	D8	110	Port A Data
A1	73		D9	113	
A2	76		D10	114	
A3	77		D11	115	
A4	78		D12	116	
A5	79		D13	117	
A6	82		D14	118	
A7	83		D15	121	
A8	84		D16	122	
A9	85		D17	123	
A10	88		D18	124	
A11	89		D19	125	
A12	92		D20	128	
A13	93		D21	131	
A14	94		D22	132	
A15	97		D23	133	
\overline{AT}	60	Port A Control	\overline{DE}	5	JTAG/OnCE
CLKOUT	59	Clock/PLL	EXTAL	55	
D0	100	Port A Data	GND_A	75	GND—Port A Address
D1	101		GND_A	81	
D2	102		GND_A	87	
D3	105		GND_A	96	
D4	106		GND_C	66	GND—Port A Control
D5	107		GND_C	58	
D6	108		GND_D	104	GND—Port A Data
D7	109		GND_D	112	

Packaging

Package and Pin-Out Information

Table 3-2 DSP56603 144-pin TQFP Pin Identification by Pin Name (Continued)

Name	Pin #	Functional Group	Name	Pin #	Functional Group
GND _D	120	GND—Port A Data	$\overline{\text{HCS}}/\text{HA10}$	30	Peripherals/HI08
GND _D	130		$\overline{\text{HDS}}/\overline{\text{HWR}}$	21	
GND _H	39	GND—HI08 Data	$\overline{\text{HREQ}}/\overline{\text{HTRQ}}$	24	
GND _P	47	GND—PLL	$\text{HRW}/\overline{\text{HRD}}$	22	
GND _{P1}	48		$\overline{\text{MCS}}$	70	Port A Control
GND _Q	19	Quiet GND (for both V _{CCQH} and V _{CCQL})	$\text{MODA}/\overline{\text{IRQA}}$	137	Mode/Interrupt Control
GND _Q	54		$\text{MODB}/\overline{\text{IRQB}}$	136	
GND _Q	90		$\text{MODC}/\overline{\text{IRQC}}$	135	
GND _Q	127		$\text{MODD}/\overline{\text{IRQD}}$	134	
GND _S	9	GND—SSI, Timer, GPIO, HI08 Control	PCAP	46	Clock/PLL
GND _S	26		$\text{PINIT}/\overline{\text{NMI}}$	6	
GPIO0	13	Peripherals/GPIO	$\overline{\text{RD}}$	68	Port A Control
GPIO1	14		$\overline{\text{RESET}}$	44	
GPIO2	15		Peripherals/SSI0	SC00	12
HA0/ $\overline{\text{HAS}}$	33	Peripherals/HI08		SC01	4
HA1/HA8	32		SC02	3	
HA2/HA9	31	Peripherals/SSI1	SC10	11	
$\overline{\text{HACK}}/\overline{\text{HRRQ}}$	23		SC11	144	
HAD0	43		SC12	143	
HAD1	42		SCK0	17	Peripherals/SSI0
HAD2	41	SCK1	16	Peripherals/SSI1	
HAD3	40	SRD0	7	Peripherals/SSI0	
HAD4	37	SRD1	1	Peripherals/SSI1	
HAD5	36	STD0	10	Peripherals/SSI0	
HAD6	35	STD1	2	Peripherals/SSI1	
HAD7	34	TCK	141	JTAG/OnCE	

Table 3-2 DSP56603 144-pin TQFP Pin Identification by Pin Name (Continued)

Name	Pin #	Functional Group	Name	Pin #	Functional Group
TDI	140	JTAG/OnCE	V _{CCH}	38	V _{CC} —HI08 Data
TDO	139		V _{CCP}	45	V _{CC} —PLL
TIO0	29	Peripherals/Timer	V _{CCQH}	20	Quiet V _{CC} High
TIO1	28		V _{CCQH}	57	
TIO2	27		V _{CCQH}	95	
TMS	142	JTAG/OnCE	V _{CCQL}	18	Quiet V _{CC} Low
$\overline{\text{TRST}}$	138		V _{CCQL}	56	
V _{CCA}	74	V _{CC} —Port A Address	V _{CCQL}	91	V _{CC} —SSI, Timer, GPIO, HI08 Control
V _{CCA}	80		V _{CCQL}	126	
V _{CCA}	86		V _{CCS}	8	
V _{CCC}	65	V _{CC} —Port A Control	V _{CCS}	25	
V _{CCD}	103	V _{CC} —Port A Data	$\overline{\text{WR}}$	67	Port A Control
V _{CCD}	111		XTAL	53	Clock/PLL
V _{CCD}	119		nc	49,50,51,52,61, 62, 63, 64, 69, 71, 98, 99	
V _{CCD}	129				

Note: The 12 pins marked as “nc” are reserved for possible future enhancements. Do not connect these pins to any power, signal, or ground traces or vias.

Packaging

Package and Pin-Out Information

Table 3-3 DSP56603 Functional Signal Groups (144 TQFP)

Name	Pin #	Functional Group	Name	Pin #	Functional Group
A0	72	Core/Port A Address	D10	114	Core/Port A Data
A1	73		D11	115	
A2	76		D12	116	
A3	77		D13	117	
A4	78		D14	118	
A5	79		D15	121	
A6	82		D16	122	
A7	83		D17	123	
A8	84		D18	124	
A9	85		D19	125	
A10	88		D20	128	
A11	89		D21	131	
A12	92		D22	132	
A13	93		D23	133	
A14	94	Core/Port A Ctrl	\overline{AT}	60	
A15	97		\overline{MCS}	70	
D0	100	Core/Port A Data	MODA/ \overline{IRQA}	137	Core/V _{CC} Port A Address
D1	101		MODB/ \overline{IRQB}	136	
D2	102		MODC/ \overline{IRQC}	135	
D3	105		MODD/ \overline{IRQD}	134	
D4	106		\overline{RD}	68	
D5	107		\overline{WR}	67	
D6	108	V _{CCA}	74	Core/V _{CC} Port A Ctrl	
D7	109	V _{CCA}	80		
D8	110	V _{CCA}	86		
D9	113	V _{CCC}	65		

Table 3-3 DSP56603 Functional Signal Groups (144 TQFP) (Continued)

Name	Pin #	Functional Group	Name	Pin #	Functional Group
V _{CCD}	103	Core/V _{CC} for Port A Data	TMS	142	Core/JTAG
V _{CCD}	111		$\overline{\text{TRST}}$	138	
V _{CCD}	119		HAD0	43	Peripherals/HI08
V _{CCD}	129	HAD1	42		
GND _A	75	Core/GND for Port A Address	HAD2	41	
GND _A	81		HAD3	40	
GND _A	87		HAD4	37	
GND _A	96		HAD5	36	
GND _C	58	Core/GND Port A Control	HAD6	35	
GND _C	66		HAD7	34	
GND _D	104	Core/GND for Port A Data	HA0/ $\overline{\text{HAS}}$	33	
GND _D	112		HA1/HA8	32	
GND _D	120		HA2/HA9	31	
GND _D	130		$\overline{\text{HCS}}$ /HA10	30	
CLKOUT	59	Core/PLL	$\overline{\text{HACK}}/\overline{\text{HRRQ}}$	23	
EXTAL	55		$\overline{\text{HDS}}/\overline{\text{HWR}}$	21	
PCAP	46		$\overline{\text{HREQ}}/\overline{\text{HTRQ}}$	24	
PINIT/ $\overline{\text{NM}}\overline{\text{I}}$	6		HRW/ $\overline{\text{HRD}}$	22	
XTAL	53		V _{CCH}	38	Peripherals/V _{CC} HI08
V _{CCP}	45	Core/V _{CC} for PLL	GND _H	39	Peripherals/GND HI08
GND _P	47	Core/GND for PLL	SC00	12	Peripherals/SSI0
GND _{P1}	48		SC01	4	
$\overline{\text{DE}}$	5	Core/JTAG	SC02	3	
TCK	141		SCK0	17	
TDI	140		SRD0	7	
TDO	139		STD0	10	

Packaging

Package and Pin-Out Information

Table 3-3 DSP56603 Functional Signal Groups (144 TQFP) (Continued)

Name	Pin #	Functional Group	Name	Pin #	Functional Group
SC10	11	Peripherals/SSI1	GND _S	9	Peripherals/GND for SSI0, SSI1, Timer, GPIO
SC11	144		GND _S	26	
SC12	143		V _{CCQH}	20	Quiet V _{CC} High
SCK1	16		V _{CCQH}	57	
SRD1	1		V _{CCQH}	95	
STD1	2		Peripherals/Timer	V _{CCQL}	18
TIO0	29	V _{CCQL}		56	
TIO1	28	V _{CCQL}		91	
TIO2	27	V _{CCQL}		126	
GPIO0	13	Peripherals/GPIO	GND _Q	19	Quiet Ground (for both V _{CCQH} and V _{CCQL})
GPIO1	14		GND _Q	54	
GPIO2	15		GND _Q	90	
V _{CCS}	8	Peripherals/V _{CC} for SSI0, SSI1, TIMER, GPIO	GND _Q	127	
V _{CCS}	25		nc	49, 50, 51, 52, 61, 62, 63, 64, 69, 71, 98, 99	

Note: The 12 pins marked as “nc” are reserved for possible future enhancements. Do not connect these pins to any power, signal, or ground traces or vias.

Power and ground pins have special considerations for noise immunity. See **Electrical Design Considerations**, on page 4-3, for more information.

Table 3-4 DSP56603 144-pin TQFP Power Supply Pins

Name	Pin #	Functional Group	Name	Pin #	Functional Group
V _{CCA}	74	Core/Port A Address	V _{CCD}	103	Core/Port A Data
V _{CCA}	80		V _{CCD}	111	
V _{CCA}	86		V _{CCD}	119	
GND _A	75		V _{CCD}	129	
GND _A	81		GND _D	104	
GND _A	87		GND _D	112	
GND _A	96		GND _D	120	
V _{CCC}	65	Core/Port A Control	GND _D	130	Core/PLL
GND _C	66		V _{CCP}	45	
GND _C	58		GND _P	47	
V _{CCQH}	20	Quiet V _{CC} High	GND _{P1}	48	Quiet GND (for both V _{CCQH} and V _{CCQL})
V _{CCQH}	57		GND _Q	19	
V _{CCQH}	95		GND _Q	54	
V _{CCLQ}	18	Quiet V _{CC} Low	GND _Q	90	Peripherals/HI08 Data
V _{CCQL}	56		GND _Q	127	
V _{CCQL}	91		V _{CCH}	38	
V _{CCQL}	126		GND _H	39	
GND _S	9	Peripherals/SSI0, SSI1, Timer, GPIO, HI08 Control	V _{CCS}	8	Peripherals/SSI0, SSI1, Timer, GPIO, HI08 Control
GND _S	26		V _{CCS}	25	

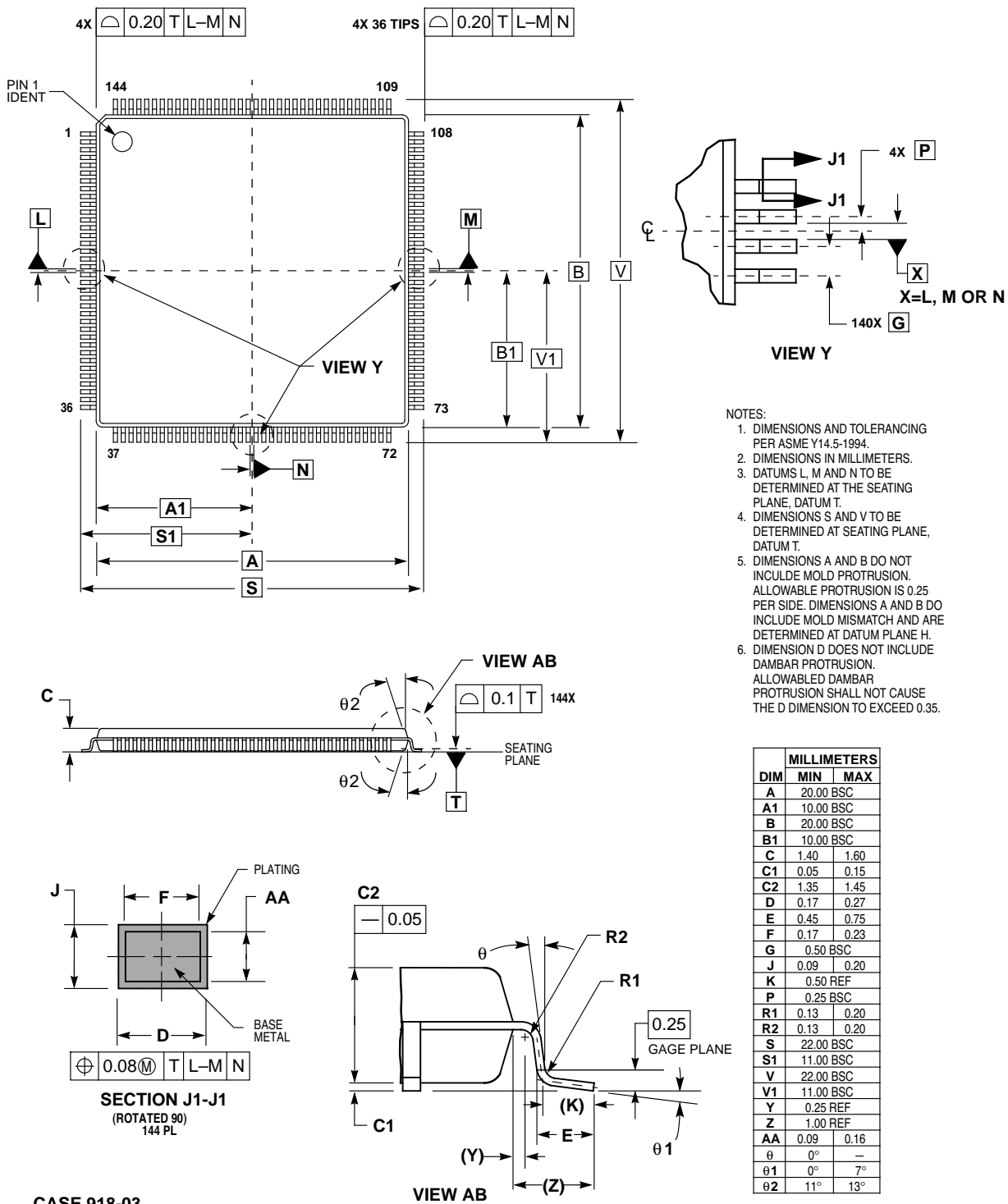

Figure 3-3 144-pin Thin Quad Flat Pack (TQFP) Mechanical Information

SECTION 4

DESIGN CONSIDERATIONS

THERMAL DESIGN CONSIDERATIONS

An estimation of the chip junction temperature, T_J , in °C can be obtained from the equation:

Equation 1: $T_J = T_A + (P_D \times R_{\theta JA})$

Where:

T_A = ambient temperature °C

$R_{\theta JA}$ = package junction-to-ambient thermal resistance °C/W

P_D = power dissipation in package

Historically, thermal resistance has been expressed as the sum of a junction-to-case thermal resistance and a case-to-ambient thermal resistance:

Equation 2: $R_{\theta JA} = R_{\theta JC} + R_{\theta CA}$

Where:

$R_{\theta JA}$ = package junction-to-ambient thermal resistance °C/W

$R_{\theta JC}$ = package junction-to-case thermal resistance °C/W

$R_{\theta CA}$ = package case-to-ambient thermal resistance °C/W

$R_{\theta JC}$ is device-related and cannot be influenced by the user. The user controls the thermal environment to change the case-to-ambient thermal resistance, $R_{\theta CA}$. For example, the user can change the air flow around the device, add a heat sink, change the mounting arrangement on the printed circuit board, or otherwise change the thermal dissipation capability of the area surrounding the device on a printed circuit board. This model is most useful for ceramic packages with heat sinks; some 90% of the heat flow is dissipated through the case to the heat sink and out to the ambient environment. For ceramic packages, in situations where the heat flow is split between a path to the case and an alternate path through the printed circuit board, analysis of the device thermal performance may need the additional modeling capability of a system level thermal simulation tool.

The thermal performance of plastic packages is more dependent on the temperature of the printed circuit board to which the package is mounted. Again,

if the estimations obtained from $R_{\theta JA}$ do not satisfactorily answer whether the thermal performance is adequate, a system level model may be appropriate.

A complicating factor is the existence of three common definitions for determining the junction-to-case thermal resistance in plastic packages:

- Measure the thermal resistance from the junction to the outside surface of the package (case) closest to the chip mounting area when that surface has a proper heat sink. This is done to minimize temperature variation across the surface.
- Measure the thermal resistance from the junction to where the leads are attached to the case. This definition is approximately equal to a junction to board thermal resistance.
- Use the value obtained by the equation $(T_J - T_T)/P_D$ where T_T is the temperature of the package case determined by a thermocouple.

As noted above, the junction-to-case thermal resistances quoted in this data sheet are determined using the first definition. From a practical standpoint, that value is also suitable for determining the junction temperature from a case thermocouple reading in forced convection environments. In natural convection, using the junction-to-case thermal resistance to estimate junction temperature from a thermocouple reading on the case of the package will estimate a junction temperature slightly hotter than actual. Hence, the new thermal metric, Thermal Characterization Parameter, or Ψ_{JT} , has been defined to be $(T_J - T_T)/P_D$. This value gives a better estimate of the junction temperature in natural convection when using the surface temperature of the package. Remember that surface temperature readings of packages are subject to significant errors caused by inadequate attachment of the sensor to the surface and to errors caused by heat loss to the sensor. The recommended technique is to attach a 40-gauge thermocouple wire and bead to the top center of the package with thermally conductive epoxy.

Note: Table 2-3 Package Thermal Characteristics on page 2-2 contains the package thermal values for this chip.

ELECTRICAL DESIGN CONSIDERATIONS

CAUTION

This device contains protective circuitry to guard against damage due to high static voltage or electrical fields. However, normal precautions are advised to avoid application of any voltages higher than maximum rated voltages to this high-impedance circuit. Reliability of operation is enhanced if unused inputs are tied to an appropriate logic voltage level (e.g., either GND or V_{CC}).

Each V_{CC} pin on the DSP56603 should be provided with a low-impedance path to the board's supply. Each GND pin should likewise be provided with a low-impedance path to ground.

The power supply pins drive distinct groups of logic on-chip as shown in **Table 1-2 Power Inputs** on page 1-3 and **Table 1-3 Grounds** on page 1-4.

For best results, separate V_{CC} and GND for each supply is recommended; each with a capacitor to bypass V_{CC} to GND as close as possible to the package.

Otherwise, a multi-layer board is recommended, employing two inner layers as V_{CC} and GND planes. Two 0.1 μF ceramic capacitors as close as possible to each side of the package (eight capacitors altogether) should be used to bypass the V_{CC} power supply layer to the ground layer. In such cases, there is no separation between the various power and ground supplies, since each one is directly tied to the appropriate plane. Therefore, the capacitors are common to all the V_{CC}/GND pairs.

The V_{CC}/GND supplies of the PLL should be well-regulated (non-switching regulators), and the pins should be provided with an extremely low impedance path to V_{CC}/GND . It is recommended that V_{CCP} should be connected to the main power supply with a special power branch. If required, filtering circuitry should be provided. If V_{CCP} and GND_P are kept separate from the other supplies, an additional larger capacitor (e.g., 47 μF) should be used between these pins.

An additional large capacitor should be placed next to the power supply itself.

Electrical Design Considerations

All output pins on the DSP56603 have fast rise and fall times. Printed Circuit Board (PCB) trace interconnection length should be minimized in order to minimize undershoot and reflections caused by these fast output switching times. This recommendation particularly applies to the address and data buses, as well as to the Port A control signals and Port B pins. Maximum PCB trace lengths on the order of 6 inches (15.24 cm) are recommended. Capacitance calculations should consider all device loads as well as parasitic capacitances due to the PCB traces. Attention to proper PCB layout and bypassing becomes especially critical in systems with higher capacitive loads because these loads create higher transient currents in the V_{CC} and GND circuits.

Drive to a valid value (e.g., connect to pull-up or pull-down resistors) all unused inputs or signals that will be inputs during reset ($\overline{\text{RESET}}$ asserted).

Every input pin should be driven to a valid value after the $\overline{\text{RESET}}$ deassertion by connecting it to a pull-up or pull-down resistor if not used. Exceptions to this are the $\overline{\text{TRST}}$, $\overline{\text{DE}}$, and TMS pins, which have internal pull-up resistors.

The $\overline{\text{RESET}}$ and $\overline{\text{TRST}}$ pins must be asserted low after power-up.

All this data relates to a single DSP56603. If multiple DSP56603 devices are on the same board, check for cross-talk or excessive spikes on the supplies caused by synchronous operation of the devices.

POWER CONSUMPTION CONSIDERATIONS

Power dissipation is a key issue in portable DSP applications. This section describes some of the factors that affect current consumption. Most of the current consumed by CMOS devices is Alternating Current (AC), which is charging and discharging the capacitances of the pins and internal nodes. Therefore, the total current consumption is the sum of these internal and external currents.

This current consumption is described by the formula:

Equation 3: $I = C \times V \times f$

where: C = node/pin capacitance (in Farads)
 V = voltage swing (in volts)
 f = frequency of node/pin toggle (in Hz)

Example 4-1 Current Consumption

For a Port A address pin loaded with 50 pF capacitance, operating at 2.7 V, and with a 60 MHz clock, toggling at its maximum possible rate of 15 MHz, the current consumption is (for this pin only):

Equation 4: $I = 50 \times 10^{-12} \times 2.7 \times 15 \times 10^6 = 2.025 \text{ mA}$

The Typical Internal Current value (I_{CCI}) reflects the typical switching of the internal buses in a typical DSP-intensive application.

For applications requiring very low current consumption, it is recommended to:

- Set the PCD bit (in the OMR) and do not use the PC-relative instructions.
- Set the EBD bit (in the OMR) when not accessing external memory
- Minimize external memory accesses and use internal memory accesses instead
- Minimize the number of pins that are switching
- Minimize the capacitive load on the pins
- Connect the unused inputs to pull-up or pull-down resistors.
- Disable unused peripherals
- Disable unused pin activity (e.g., CLKOUT, XTAL)

A common way to evaluate power consumption is to use a current per MIPS measurement methodology to minimize specific board effects (i.e., to compensate for measured board current not caused by the DSP). A benchmark power consumption test algorithm is listed in **Appendix A**. Use the test algorithm and

measure the current consumption at two different frequencies, F1 and F2. Then use the following equation to derive the current per MIPS value:

Equation 5: $I/\text{MIPS} = I/\text{MHz} = (I_{\text{typF2}} - I_{\text{typF1}})/(F2 - F1)$

where: I_{typF2} = current at F2
 I_{typF1} = current at F1
F2 = high frequency (any specified operating frequency)
F1 = low frequency (any specified operating frequency lower than F2)

Note: F1 should be significantly less than F2. For example, F2 could be 60 MHz and F1 could be 30 MHz. The degree of difference between F1 and F2 determines the amount of precision with which the current rating can be determined for an application.

PLL PERFORMANCE ISSUES

The following explanations are provided as general observations on expected PLL behavior. Measurements are preliminary and are subject to change.

Phase Skew Performance

The phase skew of the PLL is defined as the time difference between the falling edges of EXTAL and CLKOUT for a given capacitive load on CLKOUT, over the entire process, temperature and voltage ranges. For input frequencies greater than 15 MHz and $MF \leq 4$, this skew is greater than or equal to 0.0 ns and less than 1.8 ns; otherwise, this skew is not guaranteed. However, for $MF < 10$ and input frequencies greater than 10 MHz, this skew is between -1.4 ns and +3.2 ns.

Phase Jitter Performance

The phase jitter of the PLL is defined as the variations in the skew between the falling edges of EXTAL and CLKOUT for a given device in specific temperature, voltage, input frequency, MF, and capacitive load on CLKOUT. These variations are a result of the PLL locking mechanism. For input frequencies greater than 15 MHz and $MF \leq 4$, this jitter is less than ± 0.6 ns; otherwise, this jitter is not guaranteed. However, for $MF < 10$ and input frequencies greater than 10 MHz, this jitter is less than ± 2 ns.

FREQUENCY JITTER PERFORMANCE

The frequency jitter of the PLL is defined as the variation of the frequency of CLKOUT. For small MF ($MF < 10$) this jitter is smaller than 0.5%. For mid-range MF ($10 < MF < 500$) this jitter is between 0.5% and approximately 2%. For large MF ($MF > 500$), the frequency jitter is 2–3%.

INPUT (EXTAL) JITTER REQUIREMENTS

The allowed jitter on the frequency of EXTAL is 0.5%. If the rate of change of the frequency of EXTAL is slow (i.e., it does not jump between the minimum and maximum values in one cycle) or the frequency of the jitter is fast (i.e., it does not stay at an extreme value for a long time) then the allowed jitter can be 2%. The phase and frequency jitter performance results are only valid if the input jitter is less than the prescribed values.

SECTION 5

ORDERING INFORMATION

Table 5-1 lists the pertinent information needed to place an order. Consult a Motorola Semiconductor sales office or authorized distributor to determine availability and to order parts.

Table 5-1 DSP56603 Ordering Information

Part	Supply Voltage	Package Type	Pin Count	Frequency (MHz)	Order Number
DSP56603	3.0 V	Plastic Thin Quad Flat Pack (TQFP)	144	60	DSP56603PV60

APPENDIX A

POWER CONSUMPTION BENCHMARK

The following benchmark program permits evaluation of DSP power usage in a test situation. It enables the PLL. Then it disables the XTAL generation, external CLKOUT generation, external port, and PC-relative instructions. Finally it uses repeated multiply-accumulate (MAC) instructions with a set of synthetic DSP application data to emulate intensive sustained DSP operation.

This synthetic benchmark provides a structure and performance that is similar to a typical DSP-intensive algorithm, as used in the target cellular subscriber market. A typical target application consumes approximately 90% of the current used by this benchmark program.

The two listed equate files, `ioequ.asm` and `intequ.asm`, are available in print format in **Appendix B** of the *DSP56603 User's Manual, DSP56603UM/AD*, as well as electronically via the Internet on the Motorola DSP home page. The web page address is provided on the back page of this document.

```
INT_PROG equ    $0                ; Internal program memory
                                   ; starting address
INT_XDAT equ    $0                ; Internal X-data memory
                                   ; starting address
INT_YDAT equ    $0                ; INTERNAL Y-data memory

INCLUDE "ioequ.asm"
INCLUDE "intequ.asm"

list

org      P:INT_PROG

movep   #$d0,x:M_PCTL1           ; XTAL disable
                                   ; PLL enable
                                   ; CLKOUT disable

ori     #$10,omr                 ; set EBD
ori     #$20,omr                 ; set PCD

PROG_START
move    #$0,r0
move    #$0,r4
move    #$3f,m0
move    #$3f,m4

clr     a
clr     b
```

Power Consumption Benchmark

```

move    #$0,x0
move    #$0,x1
move    #$0,y0
move    #$0,y1

do      forever, _end      ; Main Loop

mac     x0,y0,a    x:(r0)+,x1    y:(r4)+,y1
mac     x1,y1,a    x:(r0)+,x0    y:(r4)+,y0
add     a,b
mac     x0,y0,a    x:(r0)+,x1
mac     x1,y1,a    y:(r4)+,y0
move    b1,x:$ff

_end

nop
nop

org     x:XDAT_START
dc     $2EB9
dc     $F2FE
dc     $6A5F
dc     $6CAC
dc     $FD75
dc     $10A
dc     $6D7B
dc     $A798
dc     $FBF1
dc     $63D6
dc     $6657
dc     $A544
dc     $662D
dc     $E762
dc     $F0F3
dc     $F1B0
dc     $829
dc     $F7AE
dc     $A94F
dc     $78DC
dc     $2DE5
dc     $E0BA
dc     $AB6B
dc     $26C8
dc     $361
dc     $6E86
dc     $7347
dc     $E774
dc     $349D
dc     $ED12
dc     $FCE3
dc     $26E0
dc     $7D99
dc     $A85E
dc     $A43F
```

```

dc      $B10C
dc      $A55
dc      $EC6A
dc      $255B
dc      $F1F8
dc      $26D1
dc      $6536
dc      $BC37
dc      $35A4
dc      $F0D
dc      $BEC2
dc      $E4D3
dc      $E810
dc      $F09
dc      $E50E
dc      $FB2F
dc      $753C
dc      $62C5
dc      $641A
dc      $3B4B
dc      $A928
dc      $6641
dc      $A7E6
dc      $2127
dc      $2FD4
dc      $57D
dc      $3C72
dc      $8C3
dc      $7540

org     y:YDAT_START
dc      $6DA
dc      $F70B
dc      $39E8
dc      $E801
dc      $66A6
dc      $F8E7
dc      $EC94
dc      $233D
dc      $2732
dc      $3C83
dc      $3E00
dc      $B639
dc      $A47E
dc      $FDDF
dc      $A2C
dc      $7CF5
dc      $6A8A
dc      $B8FB
dc      $ED18
dc      $F371
dc      $A556
dc      $E9D7

```



```
dc      $A2C4
dc      $35AD
dc      $E0E2
dc      $2C73
dc      $2730
dc      $7FA9
dc      $292E
dc      $3CCF
dc      $A65C
dc      $6D65
dc      $A3A
dc      $B6EB
dc      $AC48
dc      $7AE1
dc      $3006
dc      $F6C7
dc      $64F4
dc      $E41D
dc      $2692
dc      $3863
dc      $BC60
dc      $A519
dc      $39DE
dc      $F7BF
dc      $3E8C
dc      $79D5
dc      $F5EA
dc      $30DB
dc      $B778
dc      $FE51
dc      $A6B6
dc      $FFB7
dc      $F324
dc      $2E8D
dc      $7842
dc      $E053
dc      $FD90
dc      $2689
dc      $B68E
dc      $2EAF
dc      $62BC
dc      $A245

; End of program
```

OnCE and Mfax are trademarks of Motorola, Inc.



Motorola reserves the right to make changes without further notice to any products herein. Motorola makes no warranty, representation or guarantee regarding the suitability of its products for any particular purpose, nor does Motorola assume any liability arising out of the application or use of any product or circuit, and specifically disclaims any and all liability, including without limitation consequential or incidental damages. "typical" parameters which may be provided in Motorola data sheets and/or specifications can and do vary in different applications and actual performance may vary over time. All operating parameters, including "Typicals" must be validated for each customer application by customer's technical experts. Motorola does not convey any license under its patent rights nor the rights of others. Motorola products are not designed, intended, or authorized for use as components in systems intended for surgical implant into the body, or other applications intended to support life, or for any other application in which the failure of the Motorola product could create a situation where personal injury or death may occur. Should Buyer purchase or use Motorola products for any such unintended or unauthorized application, Buyer shall indemnify and hold Motorola and its officers, employees, subsidiaries, affiliates, and distributors harmless against all claims, costs, damages, and expenses, and reasonable attorney fees arising out of, directly or indirectly, any claim of personal injury or death associated with such unintended or unauthorized use, even if such claim alleges that Motorola was negligent regarding the design or manufacture of the part. Motorola and  are registered trademarks of Motorola, Inc. Motorola, Inc. is an Equal Opportunity/Affirmative Action Employer.

How to reach us:

USA/Europe/Locations Not Listed:

Motorola Literature Distribution
P.O. Box 20912
Phoenix, Arizona 85036
1 (800) 441-2447 or
1 (602) 303-5454

Mfax:

RMFAX0@email.sps.mot.com
TOUCHTONE (602) 244-6609

Asia/Pacific:

Motorola Semiconductors H.K. Ltd.
8B Tai Ping Industrial Park
51 Ting Kok Road
Tai Po, N.T., Hong Kong
852-2662928

Technical Resource Center:

1 (800) 521-6274

DSP Helpline

dsphelp@dsp.sps.mot.com

Japan:

Nippon Motorola Ltd.
Tatsumi-SPD-JLDC
6F Seibu-Butsuryu-Center
3-14-2 Tatsumi Koto-Ku
Tokyo 135, Japan
03-3521-8315

Internet:

<http://www.motorola-dsp.com>

