

Features

- Two PCM Codecs (ITU-T G.711/G.712, 8kHz PCM)
- Four Audio TX/RX Interfaces
- Single 3.3V Power Supply
- Flexible Voice Data Port Works in ST-bus, GCI and SSI Modes
- Serial MicroPort Interface Compatible with Motorola, Intel and National Semiconductor
- Low External Component Count
- Low Power (43mW typical)
- Power-Down Mode
- Differential Microphone Inputs
- Programmable Bias Voltage Output for Electret Microphones
- Microphone Presence Detection
- Microphone Mute
- Programmable Microphone Gain (0dB to +46.5dB in 1.5dB Steps)
- ITU-T G.712 High-Pass and Low-Pass TX Filtering
- Programmable Sidetone Gain (-39dB to +6dB in 3dB Steps)
- Sidetone Mute
- Differential Earpiece Driver Outputs
- 66mW rms into 32 Ohms

DS5320

ISSUE 1

March 2000

Ordering Information

MT92303/PR/GP1N

44 Pin MQFP

-40 to +85 C

- 150mW rms into 16 Ohms
- Programmable Earpiece Gain (-28dB to +2dB in 2dB Steps)
- Programmable RX Volume Control (-21dB to 0dB in 3dB Steps)
- RX Channel Mute
- ITU-T G.712 Low-Pass RX Filtering
- Programmable/Optional RX Hi-Pass Filter (6 Corner Frequencies in Range 40Hz-400Hz)
- Three PCM Data Formats - 16-bit Linear, companded ITU-T A-law or U-law
- Cross-Point Connects PCM Channels to any of the Four Audio TX/RX Interfaces
- Auxiliary Ringing/Announcement Input (to Loud Speaker Outputs)
- Loopback Test Mode

Applications

- Digital Telephone Sets
- VoIP Enterprise Telephones

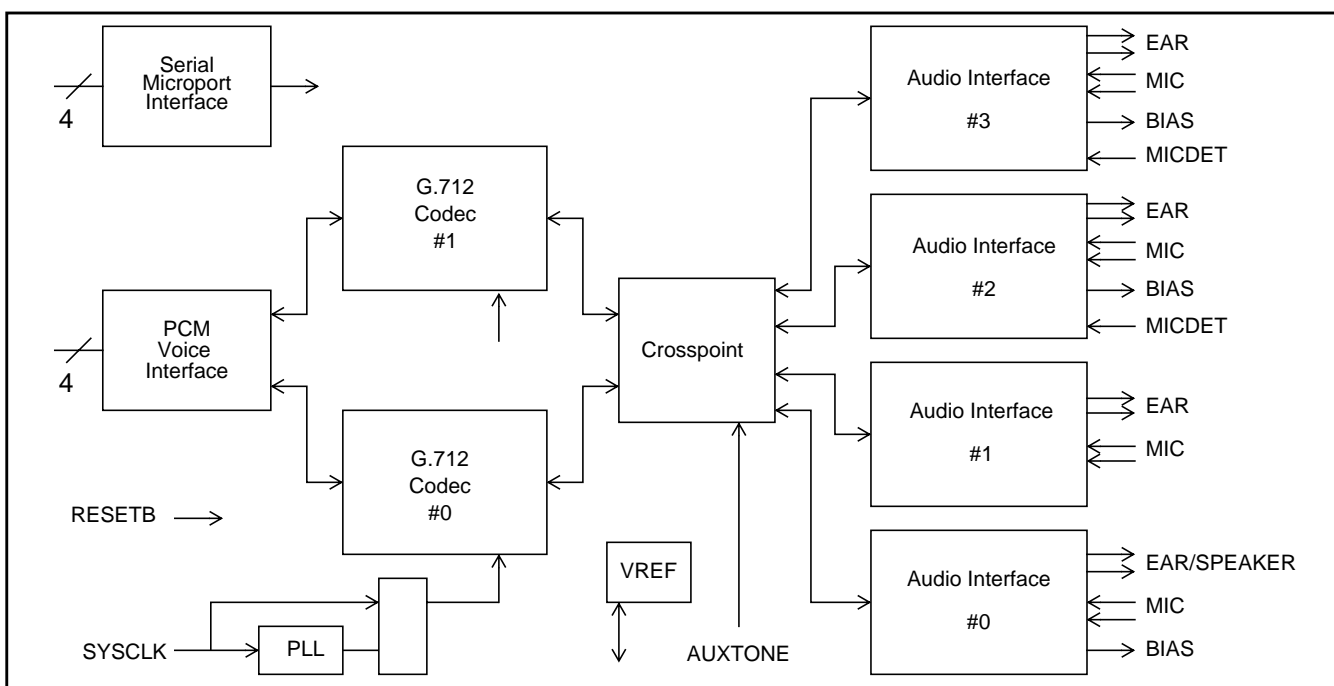

Figure 1 - Functional Block Diagram

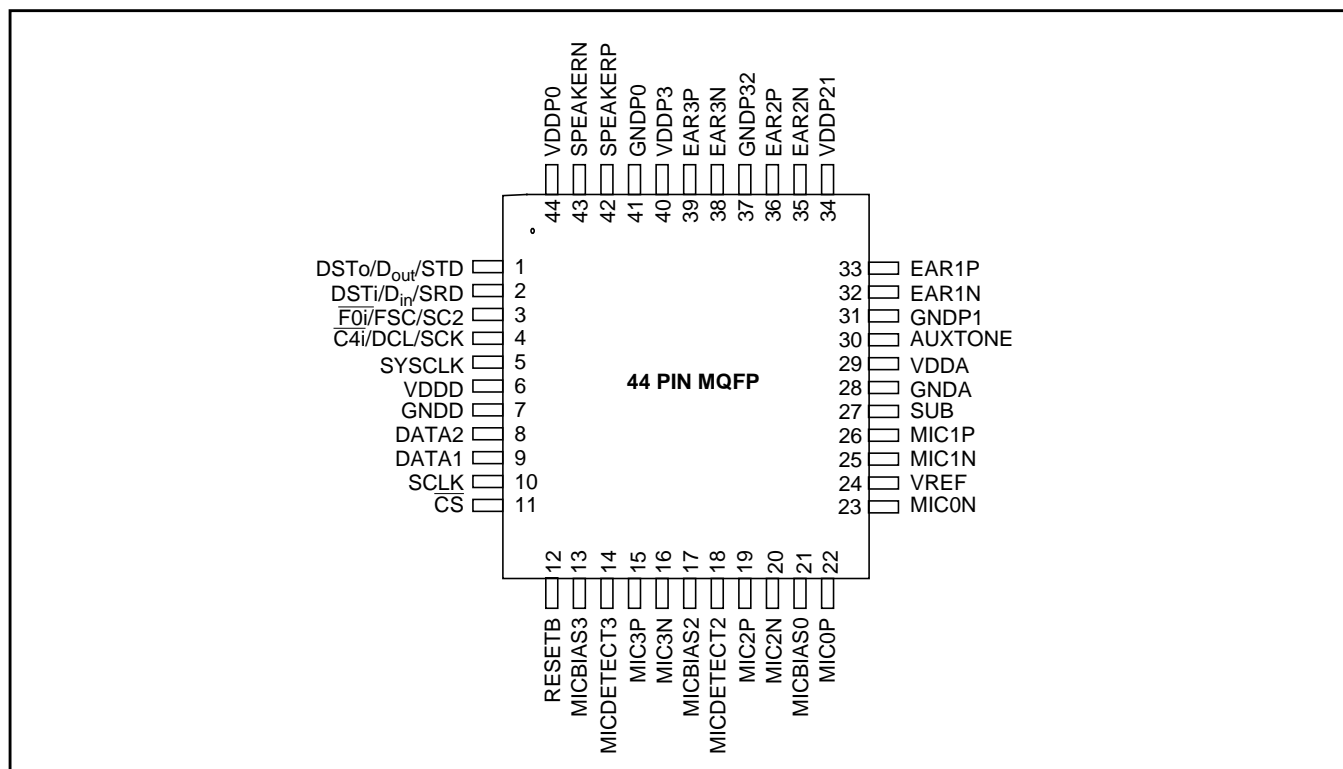

Figure 2 - Pin Description

Pin Description

| Pin # | Name | Type | Description |
|-------------------------|----------------------------|--------|--|
| System | | | |
| 5 | SYSCLK | Input | Master clock (2.048, 4.096, 10.24, 20.0, 20.48, 25.0 or 50.0MHz) |
| 12 | RESETB | Input | Active Low reset signal for digital circuitry |
| 6 | VDDD | Power | VDD for Digital circuitry and PLL |
| 7 | GNDD | Ground | GND for Digital circuitry and PLL |
| PCM Interface | | | |
| 4 | C4i/DCL/SCK | Input | Serial clock: ST-Bus = 4.096MHz, GCI = 1.536 - 4.096MHz SSI = 0.512 - 4.096MHz |
| 3 | F0i/FSC/SC2 | Input | Frame Alignment. ST-Bus active low pulse, GCI active high pulse, SSI active high |
| 2 | DSTi/D _{in} /SRD | Input | Serial data |
| 1 | DSTo/D _{out} /STD | Output | Serial data |
| Serial Microport | | | |
| 11 | CS | Input | Enables serial microport. Active low |
| 10 | SCLK | Input | Data clock for serial microport |
| 9 | DATA1 | I/O | Motorola/National mode: output. Intel mode: i/o |
| 8 | DATA2 | Input | Motorola/National mode: input. Intel mode: not used and must be tied to VDD or GND. |

Pin Description (continued)

| Analog | | | |
|-----------------------------|----------------|--------|--|
| 24 | VREF | Output | On-chip Voltage-Reference decoupling capacitor, 100nF to GNDA |
| 29 | VDDA | Power | VDD for Analog circuitry |
| 28 | GNDA | Ground | GND for Analog circuitry |
| 27 | SUB | Ground | Chip Substrate (connect to GNDA) |
| Audio Interface #3 | | | |
| 13 | MICBIAS3 | Output | Programmable voltage (0 to 2.52V in 15 steps) for Electret Microphones |
| 14 | MICDETECT3 | Input | Comparator input to detect Presence & Muting of Microphone |
| 15 | MIC3P | Input | Positive Microphone input |
| 16 | MIC3N | Input | Negative Microphone input |
| 40 | VDDP3 | Power | VDD for RX Analog O/P circuitry (Audio Interface #3) |
| 39 | EAR3P | Output | Positive Earpiece output |
| 38 | EAR3N | Output | Negative Earpiece output |
| 37 | GNDP32 | Ground | GND for RX Analog O/P circuitry (Audio Interfaces #3 & #2) |
| Audio Interface #2 | | | |
| 17 | MICBIAS2 | Output | Programmable voltage (0 to 2.52V in 15 steps) for Electret Microphones |
| 18 | MICDETECT2 | Input | Comparator input to detect Presence & Muting of Microphone |
| 19 | MIC2P | Input | Positive Microphone input |
| 20 | MIC2N | Input | Negative Microphone input |
| 36 | EAR2P | Output | Positive Earpiece output |
| 35 | EAR2N | Output | Negative Earpiece output |
| 34 | VDDP21 | Power | VDD for RX Analog O/P circuitry (Audio Interfaces #2 & #1) |
| Audio Interface #1 | | | |
| 26 | MIC1P | Input | Positive Microphone input |
| 25 | MIC1N | Input | Negative Microphone input |
| 33 | EAR1P | Output | Positive Earpiece output |
| 32 | EAR1N | Output | Negative Earpiece output |
| 31 | GNDP1 | Ground | GND for RX Analog O/P circuitry (Audio Interface #1) |
| Audio Interface #0 | | | |
| 21 | MICBIAS0 | Output | Programmable voltage (0 to 2.52V in 15 steps) for Electret Microphones |
| 22 | MIC0P | Input | Positive Microphone input |
| 23 | MIC0N | Input | Negative Microphone input |
| 44 | VDDP0 | Ground | VDD for RX Analog O/P circuitry (Audio Interface #0) |
| 43 | EAR0N/SPEAKERN | Output | Negative Earpiece output (high power for Loud Speaker) |
| 42 | EAR0P/SPEAKERP | Output | Positive Earpiece output (high power for Loud Speaker) |
| 41 | GNDP0 | Ground | GND for RX Analog O/P circuitry (Audio Interface #0) |
| Auxiliary Tone Input | | | |
| 30 | AUXTONE | Input | Auxiliary ringing/announcement input (to Loud Speaker outputs) |

Functional Description

The MT92303 Dual Codec provides complete audio to PCM interfaces including filtering and optional data companding as required by the ITU-T G.711 & G.712 recommendations. Programmable gain allows adjustment for a wide range of transducer sensitivities - two microphone amplifiers and four earpiece amplifiers are provided to allow connection to a handset, headset, auxiliary channel and microphone/speaker. A cross-point circuit allows

either Codec to be connected to any of the four Audio Interfaces. Programmable voltage sources are available for electret biasing on the Microphone channels.

PCM voice data is passed via a serial interface which operates in ST-bus, GCI or SSI mode. ST-bus mode allows the Codecs to be allocated to any of the 32 available channels. Control and programming of the Codecs is carried out over a flexible, serial, micro-controller interface.

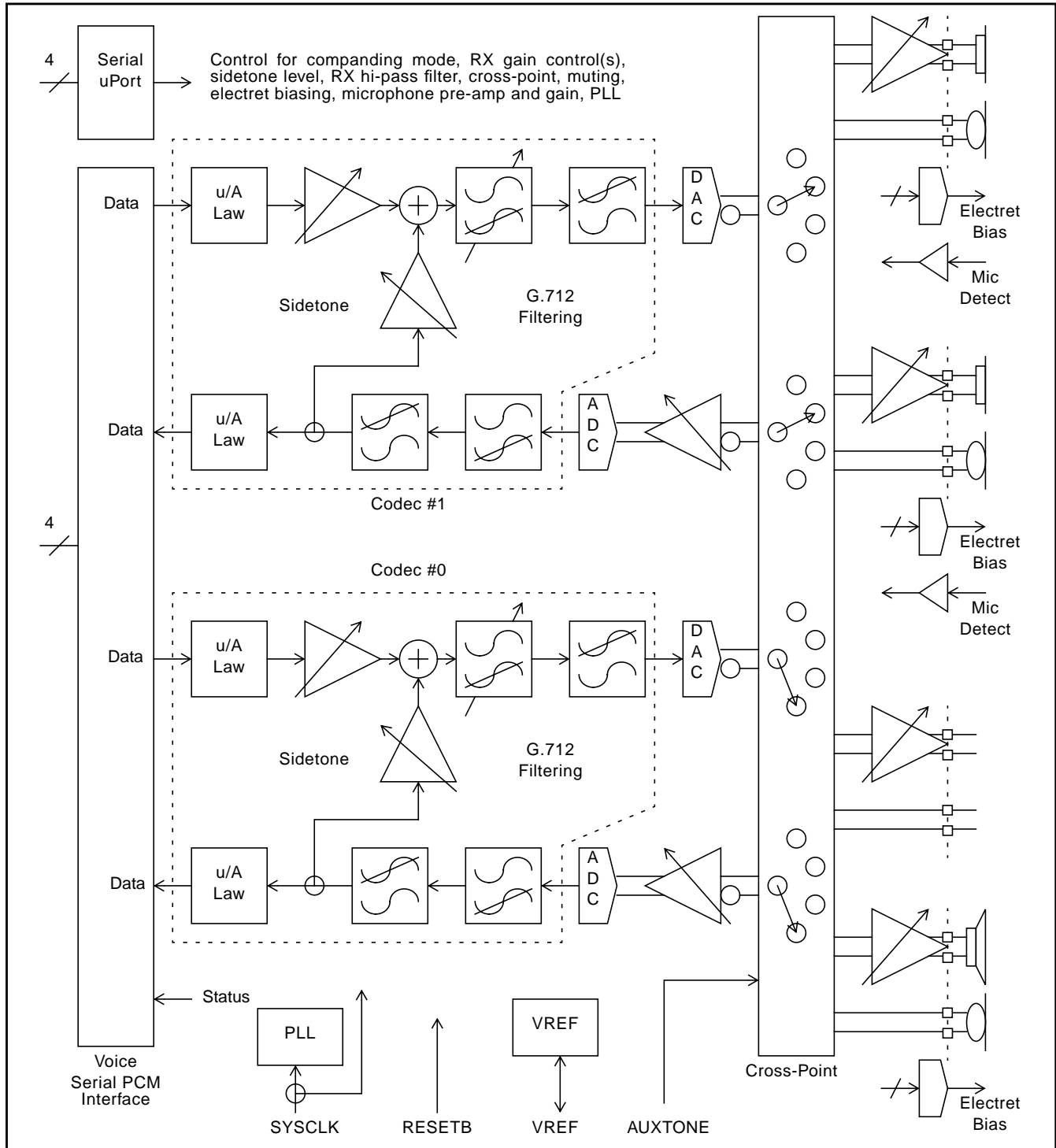

Figure 3 - Block Diagram

Voice Channel

Figure 4 shows the companding, filtering and gain stages in a single voice channel as set up by the Cross-Point. The RX channel (top) and TX channel (bottom) both use a mixture of digital-DSP and analog techniques. The DSP domain is towards the left of the diagram and extends from the PCM interface to the DAC and ADC blocks.

RX Channel

PCM data is taken in either linear or companded form and is processed by the DSP circuitry. This provides a digital volume control, an access point for sidetone, and the multi-order low-pass filtering required to remove the sampling aliases in the digitised data. The 6th order low-pass filter response is shown in Figure 5. An optional 1st order high-pass filter is also provided. In addition to the gain adjustment, the RX DSP channel may also be turned-off ('muted'). The filtered version of the data is converted to an analog signal by the DAC and continuous-time low-pass filter before passing through the Cross-Point circuitry to the variable-gain

output buffer. The buffer provides a differential output signal which allows near rail-to-rail operation and can deliver 66mW into a 32 Ohm load.

As shown in Figure 4, the RX gain may be adjusted in two places. The 'DSP' provides adjustment from -21dB to +0dB in 3dB steps, and the 'analog' from -28dB to +2dB in 2dB steps.

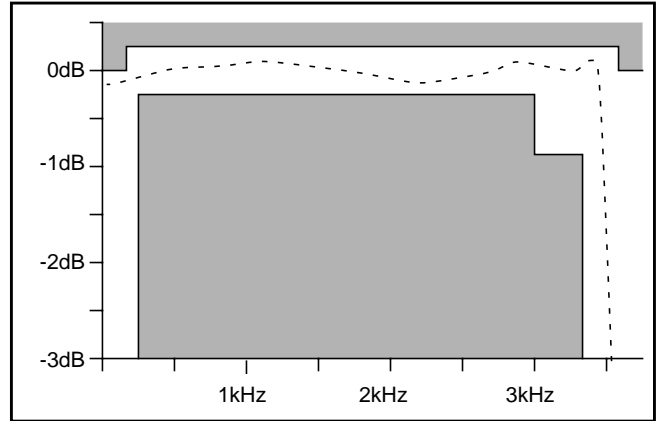

Figure 5 - RX Low-Pass Filter Response

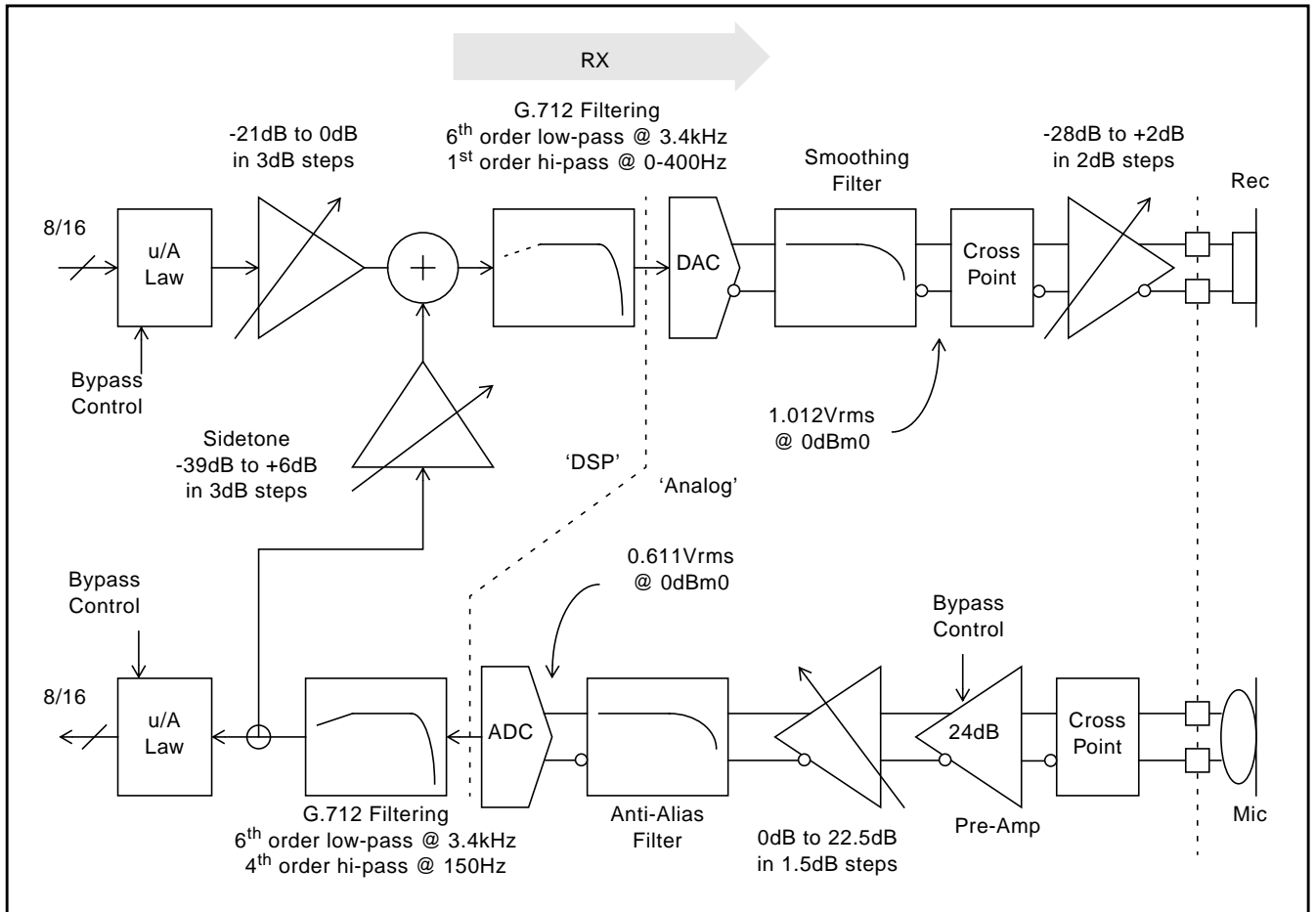

Figure 4 - Single Voice-Channel DSP and Analog Circuitry

Loud Speaker Drive

The MT92303 provides four Audio Interfaces, all of which provide the same gain adjustments and output drive voltage levels. However, Audio Interface #0 has an output buffer which is capable of delivering more current than the others, and is intended for use with a loud speaker. This output can drive 150mW r.m.s. into a 16 Ohm load - this represents almost rail-to-rail operation from the 'bridge' configured outputs.

Other loud speaker impedances may be used (as long as they are greater than or equal to 16 Ohms) and will allow a power output (t.h.d. < 1%) of:

- Power = 150mW x 16 / Rload

TX Channel

An optional pre-amp and a variable gain stage provide a very large range of gain adjustment for the microphone signal. The boosted signal is passed through an anti-alias filter before it is digitised by the ADC and routed to the DSP circuitry. The DSP band-pass filtering provides a sharp cut-off above 3.4kHz to prevent aliasing by the 8kHz sampling, and also provides a high-pass function at 150Hz to remove low-frequency voice energy.

As shown in Figure 4, the pre-amp and variable gain block combine to allow the TX gain to be adjusted from 0dB to +46.5dB in 1.5dB steps.

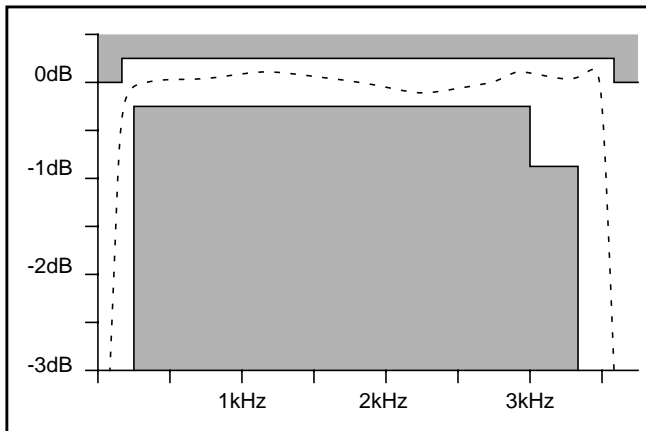

Figure 6 - TX Band-Pass Filter Response

The 8kHz samples are available in either 16-bit linear form, or 8-bit u-Law or A-Law companded form.

The differential amplifiers may be used with electret microphones as shown in Figure 8, or with dynamic microphones which have no bias requirements. Dynamic microphones may be connected directly to

the chip inputs, without the use of coupling capacitors.

DC offset voltages which potentially exist on the amplifier inputs are automatically cancelled by a sequence which runs each time the circuit is powered-up (see section 'Automatic DC Offset Cancellation').

The 'Mic' inputs of the TX channel have a differential input impedance which is sufficiently high to allow the use of small value coupling capacitors. The input impedance is formed by the internal gain-setting resistors which are used around the op-amps, and consequently the value of the input impedance is dependent on the selected gain as shown in Table 1.

| Gain | Input Impedance [‡] (kOhms) | | |
|----------------|--------------------------------------|-----|-----|
| | Min | Typ | Max |
| 0dB to 10.5dB | 49 | 107 | 213 |
| 12dB to 22.5dB | 29 | 54 | 89 |
| 24dB to 46.5dB | 52 | 80 | 113 |

Table 1. Microphone Input Impedance

[‡] These figures are for design aid only: not guaranteed and not subject to production testing.

Automatic DC Offset Cancellation (TX)

The amplifiers in the TX channel can provide gains as high as 46.5dB (linear gain of x211). Potential DC input offset voltages on the amplifier inputs need to be controlled so that they do not affect the dynamic range of the channel. These DC offset voltages are removed by a sequence which automatically runs each time the TX 'analog' circuitry is enabled/ powered-up (see control register 'Audio Interface: Enable').

The 'offset cancellation' routine works by using internal DAC's to introduce small correction voltages into the amplifiers so that their outputs have a nominal DC level of 0V (measured differentially). The digital portion of this auto calibration circuitry is clocked by the 'Frame Alignment' input and requires up to 128 clock pulses. It is important that the on-chip voltage reference is powered-up and allowed to settle before the 'offset cancellation' is initiated (by enabling the TX 'analog' circuitry).

There are two TX 'analog' channels, each of which has its own 'offset cancellation' circuitry. These can operate completely independently of each other if required.

Sidetone Path

The DSP circuitry provides a path between the TX and RX channels for the adjustment of sidetone level. In addition to the large range of adjustment, the sidetone may also be turned-off ('muted').

As shown in Figure 4, the sidetone gain may be adjusted from -39dB to +6dB in 3dB steps.

Auxiliary Tone Input

A separate analog input to the Loud Speaker Driver (Audio Interface #0) is provided for the purpose of sending auxiliary ringing/announcement tones to the loud speaker. This input ('AUXTONE') allows analog signals to be buffered by the programmable-gain driver circuit. The AUXTONE path is not normally connected, and needs to be selected by the appropriate bit in the Cross-Point control register. The analog gain from AUXTONE to the SPEAKERP/ N pins is defined by the same register as for 'RX Analog Gain' in Audio Interface #0, and is adjustable between -29dB and 0dB in approximate steps of 2dB.

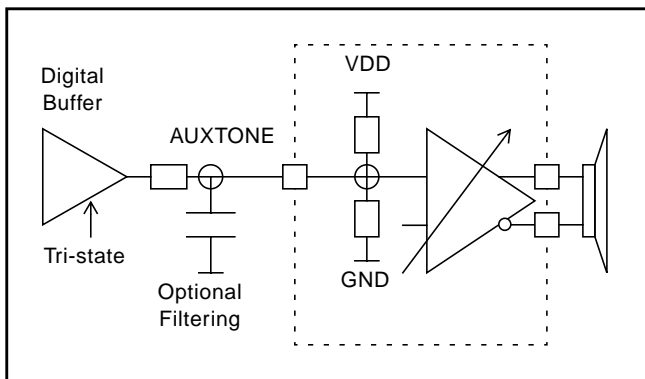

Figure 7 - AUXTONE Circuitry

The AUXTONE input may be driven by a true analog source (e.g. op-amp) or a pseudo-analog signal provided by a 'digital' driver as shown in Figure 7. For minimum external component count, the digital driver should go high-impedance when not in use (to minimize 'clicks' and 'pops').

The AUXTONE input is DC biased at VDD/2 and should be capacitively coupled to sources with a different DC level.

Cross-Point

Any 2 of the 4 RX Earpiece drivers may be selected for connection to the 2 Codecs. Similarly, any 2 of the 4 Microphones may be selected for connection to the

2 Codecs. This is done via the 'cross-point' and is controlled by the appropriate register. The same register contains two 'CON_CODEC' bits which must be 'set' in order to establish any connection to the Codecs. These bits allow the Codecs to be completely disconnected from the Audio Interfaces (the default state after System reset).

In the event of both Codecs being erroneously selected for connection to one of the Earpiece/Microphone circuits, then Codec #0 will take priority.

In the event of one of the Codecs being selected for connection to Earpiece #0 (the driver designated for the Loud Speaker), and the simultaneous selection of the AUXTONE input, then the AUXTONE path will take priority.

Electret Bias

Programmable output voltages are available on three of the Audio Interfaces - these are provided for the biasing of electret microphones as shown in Figure 8.

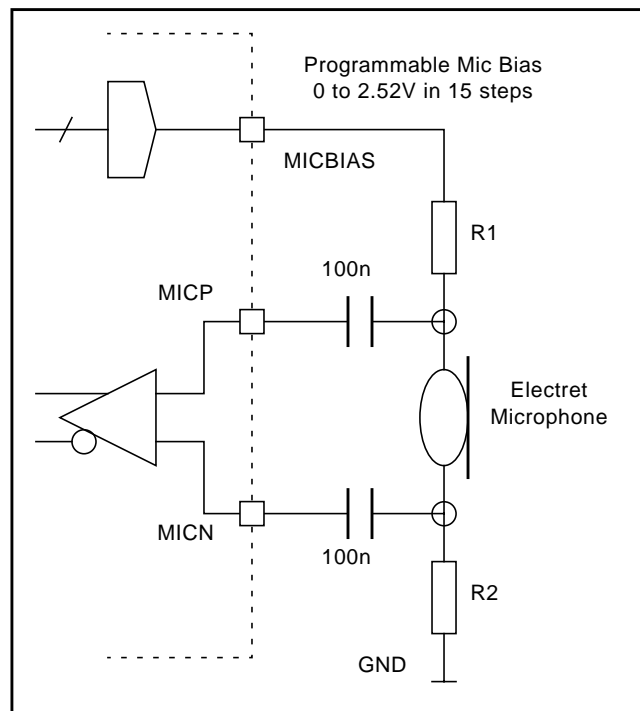

Figure 8 - Programmable Electret Bias

The electret bias is programmed via one of the control registers, and provides a stable, low noise voltage which is derived from the on-chip voltage-reference. The bias voltage is programmable from 0 to 2.52V (nominal) in 15 steps, and has a nominal output noise level of 25uV (rms, 300-3400Hz).

Microphone Presence Detect

When an electret microphone is connected as shown in Figures 8 and 9, it draws a bias current from the MICBIAS pin. The voltage across the 'bottom' bias resistor is monitored by the MICDETECT input and is used to set a 'presence' flag in the MT92303's Status Register. This allows the external controller to determine whether or not the handset and headset are plugged-in. The internal workings of the MT92303 are not affected by the state of the 'presence' flag.

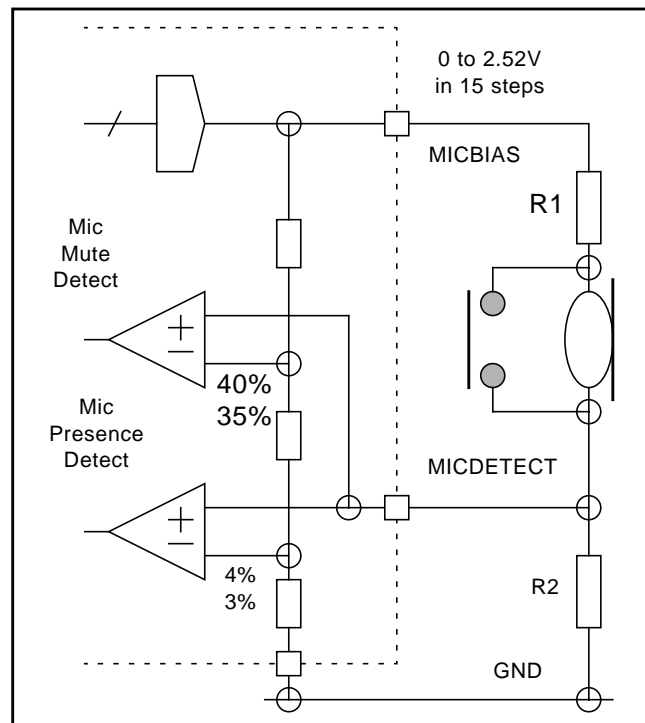

Figure 9 - Mic Presence and Mute Detect

Microphone Mute Detect

Any of the 4 Microphone inputs can be 'muted' under direct software control via the 'Mode Control' register.

In addition, the MICDETECT inputs may also be used to mute the microphone paths of the 2 associated Audio Interfaces. This allows instantaneous blanking of the microphone path, and consequently the sidetone path, and allows the 'pop' associated with electret muting to be avoided.

As shown in Figure 9, the internal 'Mic Mute Detect' signal is activated whenever the voltage across the 'bottom' bias resistor (R2) exceeds 40% of the MICBIAS voltage. A small amount of hysteresis is implemented such that the voltage needs to fall

below 35% of the MICBIAS voltage before the internal 'Mic Mute Detect' signal is deactivated.

In addition to internally muting the microphone channel, the 'Mic Mute Detect' signal is passed to the MT92303's Status Register.

The behaviour of the mute function can be programmed to operate in four different ways.

| MUTE MODE | Mute Operation (see Figure 9) |
|-----------|--|
| 00 | Microphone path enabled (normal operation). 'Mic Mute Detect' signal ignored. |
| 01 | Microphone path disabled (muted) while 'Mic Mute Detect' signal is high, and enabled while low. |
| 10 | Microphone path disabled (muted) while 'Mic Mute Detect' signal is high, but must be re-enabled by the external controller. |
| 11 | Microphone path disabled (muted). 'Mic Mute Detect' signal ignored. |

Table 2. Microphone Mute Detection

It is important to note that in the third mode (MUTEMODE=10) described in table 2, it is the designer's responsibility to re-enable the microphone path after it has been muted by the MICDETECT pin. This allows the designer to re-establish the signal path after a time sufficient for the settling of any microphone bias circuitry.

The on-chip 'Status' register provides access to the internal 'Mic Mute Detect' signal, and also the acknowledged version 'Mute' which denotes whether or not the microphone channel is actually muted. These two bits of information are expected to be used by the external controller to determine when the channel needs to be re-enabled. This will be when 'Mute' is high, and 'Mic Mute Detect' has fallen low, but the external controller may introduce a delay before re-establishing the microphone path. The path should be re-enabled by momentarily switching to MUTEMODE=00.

Bandgap Voltage Reference

The MT92303 has its own internal bandgap voltage reference which determines the absolute gains of the TX & RX paths. The bandgap voltage is brought out to the VREF pin for external decoupling with a capacitor (100nF to GNDA) that should be located as

close to the package as possible. The bandgap voltage has a nominal value of 1.26V and may be used by other external circuitry as long as this is not allowed to interfere with the reference voltage. The reference voltage is not designed to deliver current so it should not be connected to a resistive load, or an AC noise source which cannot be decoupled by the external capacitor alone.

The reference voltage circuit may be powered up and down under the control of one of the internal registers. When it is powered up, the reference voltage will take <1ms to settle.

PCM Interface (Voice & Status)

The TX and RX digitised voice data is accessed via the PCM interface which can be programmed to work in one of three modes. These are ST-bus, GCI and SSI mode as described below. The contents of an on-chip 'Status' register may also be read via this interface. The DSTo/Dout/SDT pin is high impedance when inactive - this allows multiple codecs to share the PCM bus.

| Pin Name | Type | Description |
|----------------------------|--------|---|
| $\overline{C4i}/DCL/SCK$ | Input | Serial clock. ST-Bus = 4.096MHz GCI = 1.536 - 4.096MHz SSI = 0.512 - 4.096MHz |
| $\overline{F0i}/FSC/SC2$ | Input | Frame Alignment. ST-Bus active low pulse GCI active high pulse SSI active high |
| DSTi/D _{in} /SRD | Input | Serial data |
| DSTo/D _{out} /STD | Output | Serial data |

Table 3. PCM Interface Pin Description

PCM codes which are equivalent to a 'digital mW' (0dBm0) for a 1kHz sinewave are shown in table 4. ITU-T G.711 defines the peak coding level for A-law as 3.14dBm0 and for u-Law as 3.17dBm0.

| Phase | A-Law | u-Law | Linear |
|-------|----------|----------|------------------|
| -7/8 | 00110100 | 00011110 | 1101110110000100 |
| -5/8 | 00100001 | 00001011 | 1010111010000100 |
| -3/8 | 00100001 | 00001011 | 1010111010000100 |
| -1/8 | 00110100 | 00011110 | 1101110110000100 |
| 1/8 | 10110100 | 10011110 | 0010001001111100 |
| 3/8 | 10100001 | 10001011 | 0101000101111100 |
| 5/8 | 10100001 | 10001011 | 0101000101111100 |
| 7/8 | 10110100 | 10011110 | 0010001001111100 |
| | | | |
| -Full | 00101010 | 00000000 | 1000000000000000 |
| Zero | 11010101 | 11111111 | 0000000000000000 |
| +Full | 10101010 | 10000000 | 0111111111111111 |

Table 4. PCM Coding

The A-law and u-Law schemes use sign-magnitude data, and the Linear system uses 2's compliment. The data words are shown as MSB first.

Table 4 also shows the coding for full-scale and 'zero' ('quiet code').

ST-Bus Interface

The ST-BUS consists of output (DSTo) and input (DSTi) serial data streams, a synchronous clock input signal ($\overline{C4i}$), and a framing pulse input ($\overline{F0i}$). These are shown in Figure 10. The data streams operate at 2048 kb/s and are Time Division Multiplexed into 32 identical channels of 64 kb/s bandwidth. A frame pulse (a 244 nSec low going pulse) is used to parse the continuous serial data streams into the 32 channel TDM frames. Each frame has a 125 uSecond period translating into an 8 kHz frame rate. Data is arranged MSB first. A valid frame begins when $\overline{F0i}$ is logic low coincident with a falling edge of $\overline{C4i}$. Refer to Mitel applications note MSAN-126 for detailed ST-BUS timing. $\overline{C4i}$ has a frequency (4096 kHz) which is twice the data rate. This clock samples the incoming data on DSTi at the 3/4 bit-cell position (the second rising clock edge) and makes data available on DSTo at the start of the bit-cell. A bit cell is the 2 clock cycles used to transfer 1 data bit. See Figure 17 in the electrical characteristics section for detailed timing information.

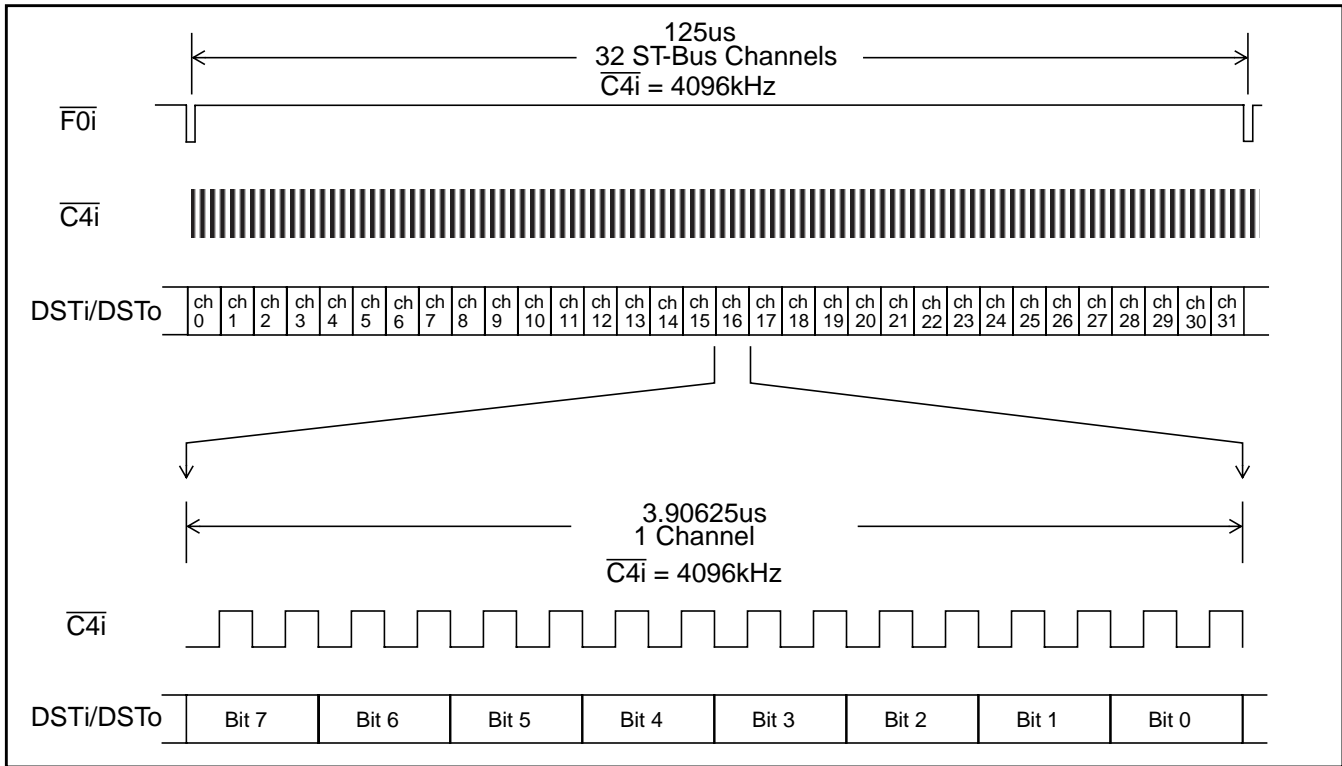

Figure 10 - ST-Bus Channel Allocation in a Frame Pulse

Channel Definition (ST)

Each Codec requires 1 (companded PCM) or 2 (linear PCM) channels. In addition to these 2 or 4 channels there is a ‘status’ channel. The allocation of these channels is fully programmable, subject to the following:

- Data-in and data-out are in the same channel slot for the DSTi and DSTo streams.
- In 16bit linear mode the 2 bytes are in adjacent channels.

This will allow multiple MT92303s to share the ST-Bus (10 in companded and 6 in linear mode).

In the event of the codecs or the status register erroneously having the same channel allocation, the prioritisation is (highest first): codec0, codec1, status. Only the highest priority has access to the PCM channel.

General Circuit Interface (GCI)

In GCI mode the number of channels available in a 125us frame pulse period depends on the DCL clock frequency, a DCL clock frequency of 1536kHz allows 3 channels, 2048kHz allows 4 channels and 4096kHz allows 8 channels.

Each channel is allocated 4 consecutive bytes which are defined as:

- PCM data bytes B1 and B2.
- Monitor byte (M).
- Control/Indication byte (C/I).

For the MT92303 only the B1 and B2 bytes are used, during the M and C/I bytes, Dout is tristate. The serial data streams are Din and Dout, the clock is DCL and the frame pulse is FSC, as shown in Figure 11. Data is arranged MSB first.

The channels selected must be compatible with the DCL clock frequency being used. The ‘status’ register information is also output on one other channel, in the B1 slot. GCI mode is enabled by setting the appropriate bits in the control register.

The clock rate for GCI is double the bit rate. See Figure 18 in the electrical characteristics section for detailed timing information.

Channel Definition (GCI)

The PCM data will be output on the channels defined by the Channel Allocation Registers. The Status register is also output on one other channel on B1 as defined by the Status Channel Allocation Register.

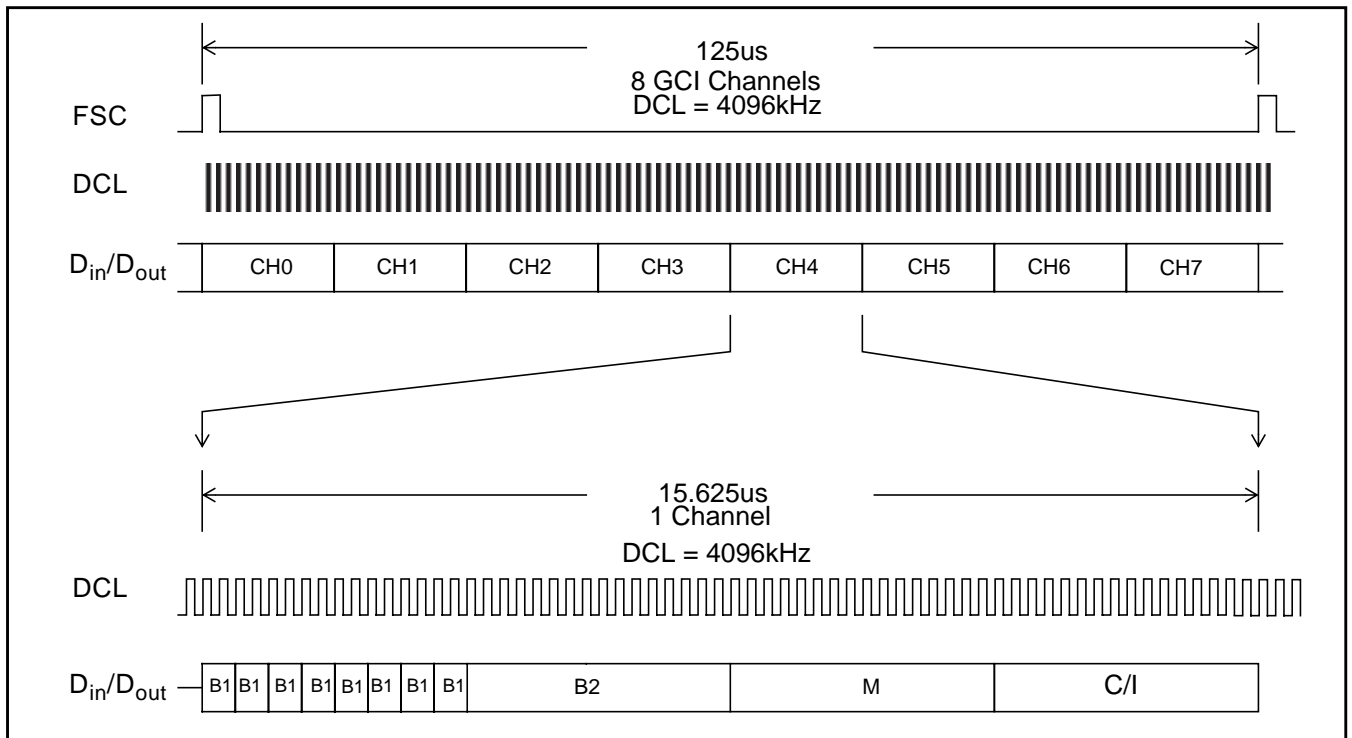

Figure 11 - GCI Channel Allocation in a Frame Pulse

No error checking is done so the channels defined must be compatible with the DCL clock frequency.

In the event of codecs or status reg. erroneously having the same channel allocation, the prioritisation is (highest first): codec0, codec1, status. Only the highest priority has access to the PCM channel.

Synchronous Serial Interface (SSI)

This is a commonly used standard in North America. There is no predefined number of bits in a 125us period, instead data is transmitted whilst the serial chip select pin SC2 is high. Data is input on SDR, being sampled on the falling edge of SCK, data is

output on SDT on the rising edge of SCK. Data is arranged MSB first. The clock rate for SSI is the same as the bit rate. See Figure 19 in the electrical characteristics section for detailed timing information.

Channel Definition (SSI)

In dual codec mode, codec0 data is transmitted first, either as 8-bit companded or 16-bit linear, then codec1 data and finally the status register. In single codec mode, the codec data is transmitted first and then the status register.

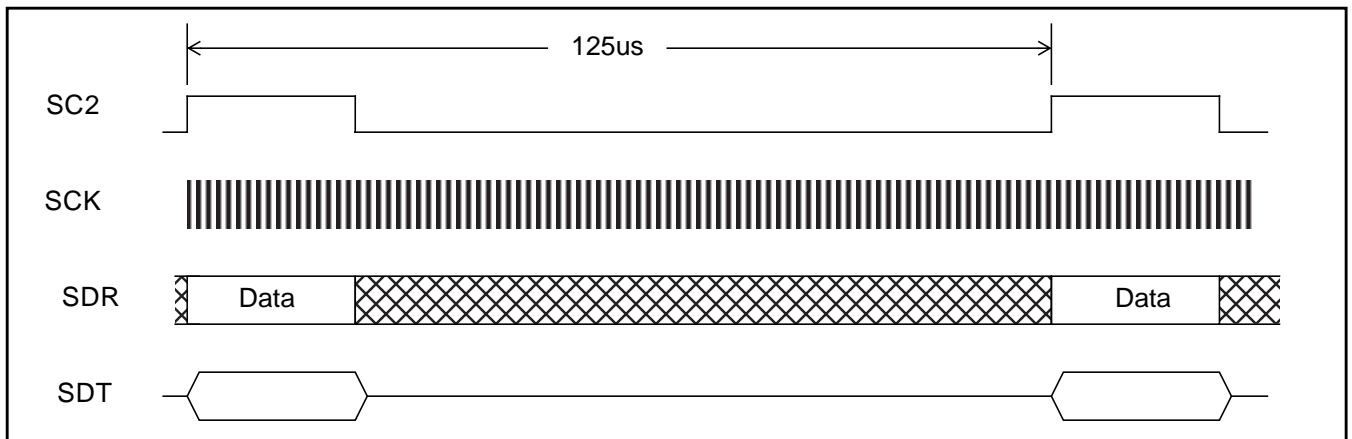

Figure 12 - Synchronous Serial Interface (SSI)

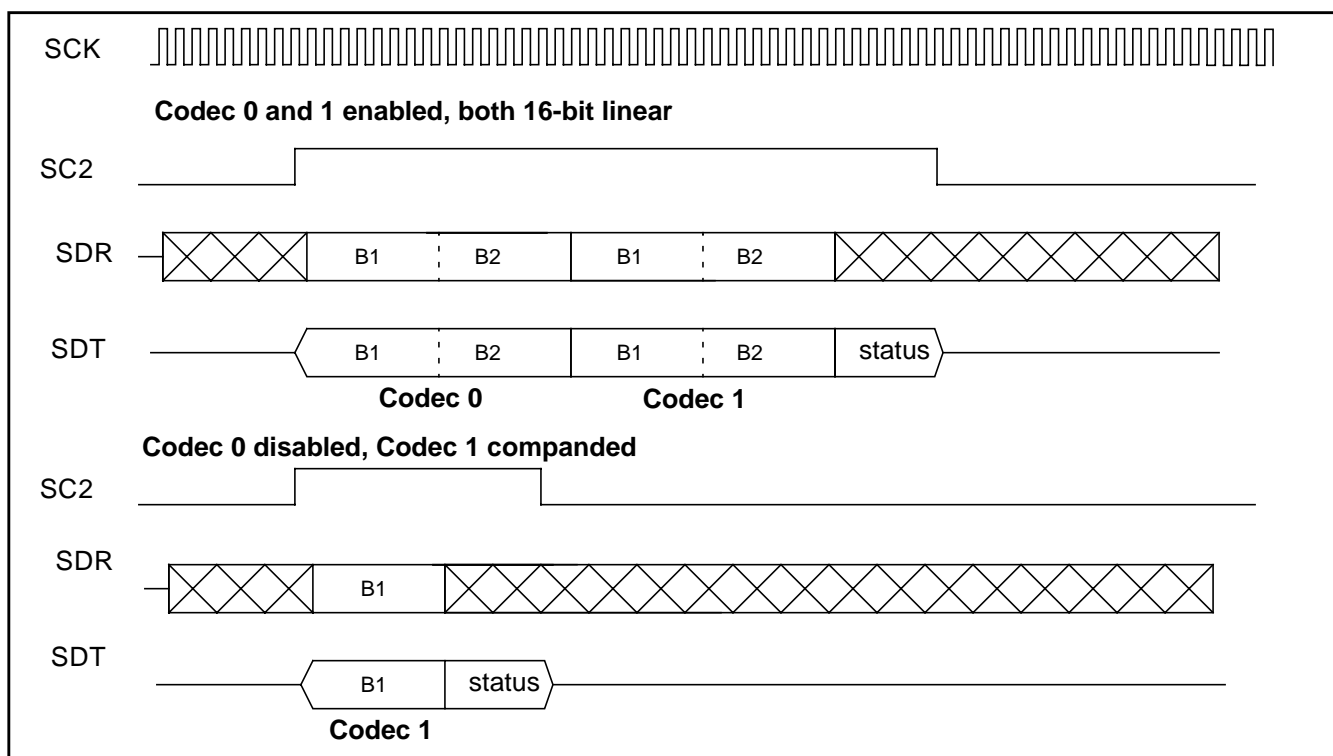

Figure 13 - SSI Bit Allocation

Serial Microport

All MT92303 internal registers are accessed for write via the serial microport to allow programming of the device. In addition some registers may be read via this interface as defined in the 'Programming and Registers' section.

| Pin Name | Type | Description |
|-----------------|-------|---|
| \overline{CS} | Input | Enables serial microport. Active Low. |
| SCLK | Input | Data clock for serial microport |
| DATA1 | I/O | Motorola/National mode: DATA1 is output. Intel mode: DATA1 is I/O. |
| DATA2 | Input | Motorola/National mode: DATA2 is input. Intel mode: DATA2 is not used and must be tied to VDD or GND |

Table 5. Microport Pin Description

The serial microport is compatible with Intel MCS-51 (mode 0), Motorola SPI (CPOL=0, CPHA=0), and National Semiconductor Microwire specifications.

Functional waveforms are shown in Figures 14 and 15. Detailed timing diagrams are shown in Figures

20 and 21 in the electrical characteristics section. The microport consists of a transmit/receive data pin (DATA1), a receive data pin (DATA2), a chip select pin (\overline{CS}) and a synchronous data clock pin (SCLK). Receive data bits are sampled on the rising edge of SCLK while transmit data is clocked out on the falling edge of SCLK. The MT92303 automatically adjusts its internal timing and pin configuration to conform to Intel or Motorola/National requirements. The microport dynamically senses the state of the SCLK pin each time \overline{CS} pin becomes active (i.e. high to low transition). If SCLK pin is high during \overline{CS} activation, then Intel mode 0 timing is assumed. In this case DATA1 pin is defined as a bi-directional (transmit/receive) serial port and DATA2 is internally disconnected. If SCLK is low during \overline{CS} activation, then Motorola/National timing is assumed and DATA1 is defined as the data transmit pin while DATA2 becomes the data receive pin.

The MT92303 supports Motorola half-duplex processor mode (CPOL=0 and CPHA=0). This means that during a write to the MT92303 by the Motorola-type processor, output data from the DATA1 pin must be ignored (by the processor). This also means that input data on the DATA2 pin is ignored by the MT92303 during a valid read by the Motorola processor. All data transfers through the microport are two bytes long. This requires the transmission of a Command/Address byte followed by the data byte to be written to or read from the addressed register. \overline{CS} must remain low for the duration of this two-byte

transfer. As shown in Figures 14 and 15 the falling edge of \overline{CS} indicates to the MT92303 that a microport transfer is about to begin. The first 8 clock cycles of SCLK after the falling edge of \overline{CS} are always used to receive the Command/Address byte from the microcontroller. The Command/Address byte contains information detailing whether the second byte transfer will be a read or a write operation (read = 1, write = 0), and at what address. The next 8 clock cycles are used to transfer the data byte between the MT92303 and the microcontroller. At the end of the two-byte transfer, \overline{CS} is brought high again to terminate the session. The rising edge of \overline{CS} will tri-state the DATA1 pin. The DATA1 pin will remain tri-stated as long as \overline{CS} is high. Intel processors utilize Least Significant Bit (LSB) first transmission while Motorola/National processors use Most Significant Bit (MSB) first transmission. The

MT92303 microport automatically accommodates these two schemes for normal data bytes. However, to ensure timely decoding of the R/W and address information, the Command/Address byte is defined differently for Intel and Motorola/National operations.

Note: SCLK needs to be pulsed once after \overline{CS} is deactivated at the end of a microport 'write'. This can be done by:

- Running SCLK continuously.
- Reading/Writing to another device (which could be a dummy) after each microport 'write'. This will force SCLK active while \overline{CS} is high.

Future versions of the MT92303 may not require this 'extra' SCLK cycle.

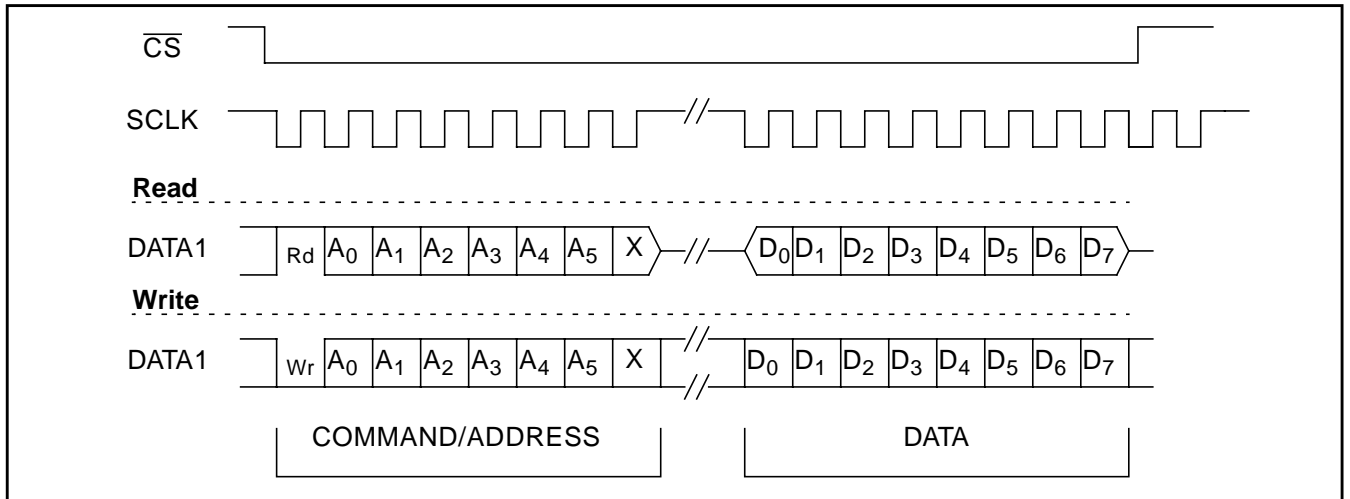

Figure 14 - Microport Waveform (Intel mode)

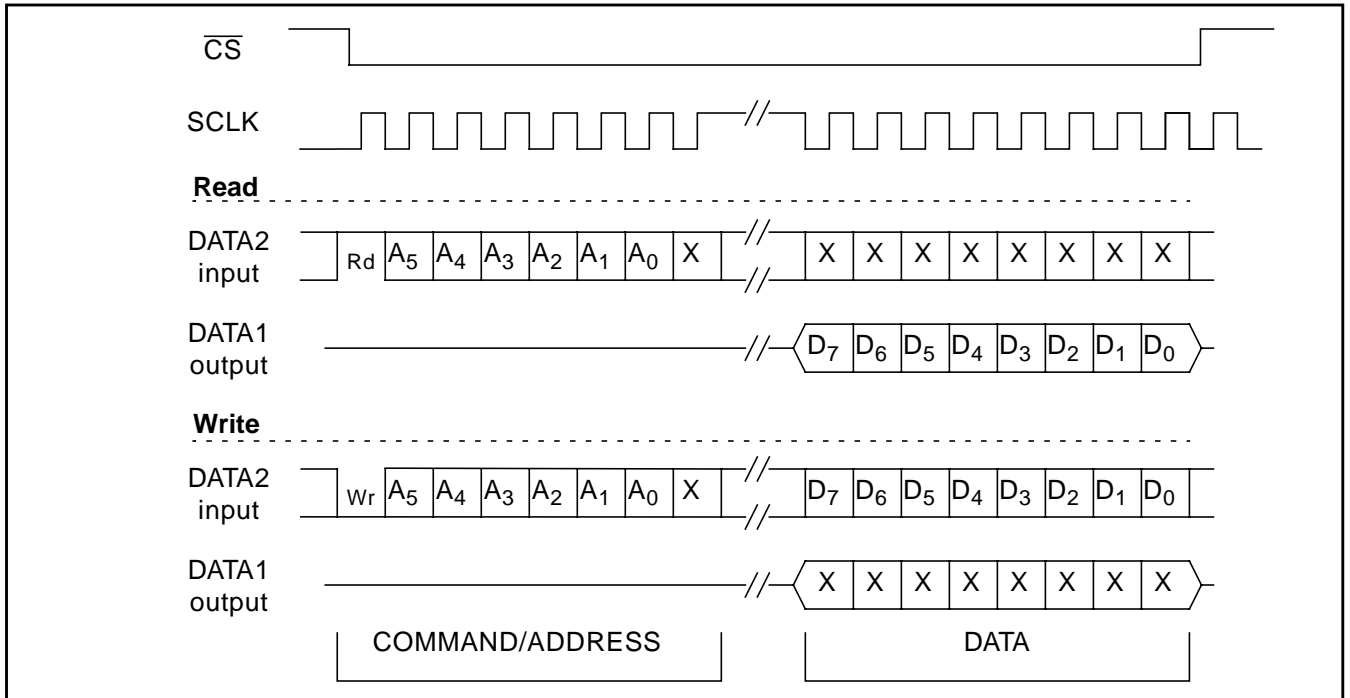

Figure 15 - Microport Waveform (Motorola/National mode)

System Clock

The MT92303 requires a 'system' clock signal which is used to run the internal DSP circuitry. The MT92303 is designed to work with several popular clock frequencies as shown in table 6. The 'system' clock should be presented to the 'SYSCLK' input (standard digital input), and the appropriate on-chip register should be programmed with the chosen frequency.

| System Clock MHz | Clocking Method | Required Frame Alignment Frequency |
|------------------|-----------------|------------------------------------|
| 20.48 | Direct | 8kHz, synchronous |
| 20.0 | Direct | 8kHz +/-400ppm |
| 25.0 | Direct | 8kHz +/-320ppm |
| 50.0 | Direct | 8kHz +/-320ppm |
| 2.048 | Internal PLL | 8kHz, synchronous |
| 4.096 | Internal PLL | 8kHz, synchronous |
| 10.24 | Internal PLL | 8kHz, synchronous |

Table 6. SYSCLK Frequencies

Only the frequencies shown in table 6 may be used - this is a requirement of the internal DAC's and ADC's which are of the 'over-sampling' type. The SYSCLK frequency needs to be a multiple of the 8kHz frame rate, and also the internal sampling clocks of the DAC's and the ADC's.

Some of the SYSCLK frequency options use an internal PLL to multiply the clock up to 20.48MHz, but the faster SYSCLK frequencies are used directly by the DSP circuitry.

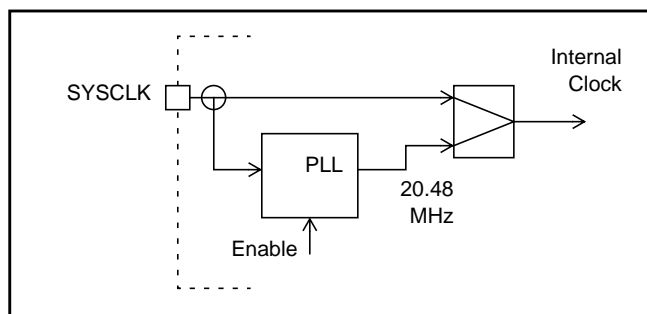

Figure 16 SYSCLK Input and PLL

Those SYSCLK frequencies which are multiples of 2.048MHz are expected to be derived from the same source as that which provides the PCM Interface's 'Frame Alignment' signal (F0i/FSC/SC2). The two signals must be synchronous - one of the ways that this can be achieved is by using the *same* clock signal for both SYSCLK and C4i/DCL/SCK (as shown

in the Application Diagram, Figure 23 - pins 4 and 5 are connected together).

The other SYSCLK frequencies are intended for use in VoIP applications where Ethernet clocks may already be available. The MT92303 contains a digital re-synchronization circuit which means that the 20.0, 25.0 or 50.0MHz SYSCLK does not need to be synchronous with the 'Frame Alignment' signal. However, in these cases, there are minimum requirements for the accuracy of the 8kHz 'Frame Alignment' frequency, as shown in table 6.

It is important to note that the accuracy Figures in table 6 (e.g. 8kHz +/-320ppm for 25MHz System Clock) are defining the *relative* inaccuracy of the two clocks (8kHz and 25MHz in this example). The two clock frequencies must share the 320ppm of allowable inaccuracy (e.g. 8kHz +/-160ppm and 25MHz +/-160ppm).

The internal PLL must be enabled whenever it is required. This is controlled by the same register as is used to select the SYSCLK frequency. The PLL will take <1ms to lock onto the SYSCLK signal - during this time the 'DSP' circuitry will be clocked at the wrong frequency (slower, or faster), and consequently the PCM data should not be relied upon until the PLL has settled. When the PLL is not needed, or when a 'low power' mode is required, then the PLL should be disabled.

The PLL should not be enabled until the SYSCLK clock signal has been applied. It is acceptable to simultaneously select the SYSCLK frequency and enable the PLL. After a System Reset, the MT92303 will be in a 'Direct' clocking mode (20.48MHz Direct as shown in table 6), and consequently must be put into a mode where the PLL is programmed to multiply the SYSCLK frequency by the correct amount, and where the PLL is 'enabled' (if the PLL is required).

System Reset Options

The MT92303 has a 'RESET' mode in which all the Control Registers, the DSP, and all other latched functions are 'reset'. This 'RESET' mode may be initiated in three different ways:-

- Powering-up the device
- Using the active-low 'RESETB' pin
- Setting the 'SW_RESET' bit in the appropriate register

The 'software' reset is programmed via the Microport Interface, and is *cleared* automatically by the next rising edge on the Microport Interface's serial clock input ('SCLK'). See note below.

Note: When the 'software' reset is *cleared* as described above, it is important that the SCLK clock edge is not regarded by the MT92303 as part of a Microport 'read' or 'write' operation. The 'SCLK' rising clock edge must consequently be applied while the \overline{CS} pin is inactive (high). Future versions of the MT92303 may use a different method to clear the 'software' reset.

Power-Down Mode

The individual circuits of the MT92303 are capable of being powered-down when not needed. This allows the operating current to be minimised, and it also allows the whole chip to be powered-down into a micro-power state if required.

The circuits are powered-down under the control of the relevant register bits. In general, the circuitry is powered-down after a power-on-reset or hardware or software reset, and is usually 'enabled' when required. To put the MT92303 into micro-power mode, then all of the circuits listed below need to be 'disabled' by setting the register bits low. For absolute minimum power consumption, the System Clock must also be stopped.

- Audio Interfaces #0 to #3 ('EN_AUDIO' x4)
- TX analog #0 and #1 ('EN_TX' x2)
- Voltage reference ('EN_VREF' x1)
- PLL ('EN_PLL' x1)
- Codecs #0 and #1 ('EN_CODEC' x2)

Loopback Testing

Digital-to-digital 'loopback' testing may be enabled by the appropriate bit in the 'DSP Test' register. In this mode, the voice data which is normally fed to the RX DAC inputs is sent to the TX DSP inputs (which are normally fed by the TX ADC).

The transfer of data from the RX domain to the TX domain is not straightforward since the sample rates and resolutions of the DAC and ADC are not the same. This results in some scrambling of the data and as a consequence, a sinewave input signal will not result in a sinewave output signal. However, the loopback path is formed from digital circuitry (PCM port, DSP filtering, DSP gains) and will behave in a strictly repeatable, bit-wise fashion. The integrity of

the loopback path can consequently be verified by the use of fixed digital vectors. To ensure a fixed, repeatable response from the DSP circuitry, the application of loopback vectors should be preceded by a System Reset.

MT92303 Programming & Registers

All operating modes, power up/down, gain levels and muting, electret biasing, filter cut-off's etc are set by the contents of the registers shown below. These are all accessed via the microport. Some of the registers are write-only, some are read-write, and the 'Status' register is read-only. The 'hex' addresses and read/write access are shown at the top of each table. Note that most of the registers are duplicated - there are generally 2 addresses for registers which control the Codecs, and 4 addresses for those which control the Audio Interfaces.

Register Defaults

The MT92303 has an on-chip 'Power On Reset' circuit which is used to clear and initialize the circuitry whenever power is applied to the device. The RESETB pin may also be used to provide a 'hardware' reset which produces the same effect. In this state, all the register bits are reset to '0'

Figure 22 shows a flow diagram with a suggested register programming sequence.

| Address 00h/01h Write only | | Codec: Control (Registers x2) |
|-------------------------------|---------|-------------------------------|
| 0 | MUTE_V | 'DSP' RX Mute |
| 1 | MUTE_S | 'DSP' Sidetone Mute |
| 2 | PCM | 0=Linear 1=Companded |
| 3 | u/A Law | 0=A Law 1=u Law |
| 4-7 | - | UNUSED (Don't care) |

| Address 02h/03h Write only | | Codec: Enable and RX DSP Gain (Registers x2) |
|-------------------------------|----------|---|
| 0 | EN_CODEC | Enable Codec |
| 1 | VOL[0] | 'DSP' RX Volume Control from -21dB to 0dB in 3dB steps. See table below |
| 2 | VOL[1] | |
| 3 | VOL[2] | |
| 4-7 | - | UNUSED (Don't care) |

| VOL[2:0] | GAIN dB |
|----------|---------|
| 000 | 0 |
| 001 | -3 |
| 010 | -6 |
| 011 | -9 |
| 100 | -12 |
| 101 | -15 |
| 110 | -18 |
| 111 | -21 |

| Address 04h/05h Write only | | Codec: RX Hi-Pass-Filter (Registers x2) |
|-------------------------------|----------|---|
| 0 | RXHPF[0] | Cut Off Frequency of RX Path 'DSP' Hi Pass Filter (1 st order filter). See table below |
| 1 | RXHPF[1] | |
| 2 | RXHPF[2] | |
| 3 | SCAN[0] | Scan-path test modes. (Defaults to '00'. Do not over-write with different value) |
| 4 | SCAN[1] | |
| 5-7 | - | UNUSED (Don't care) |

| Address 06h/07h Write only | | Codec: Sidetone Gain (Registers x2) |
|-------------------------------|----------|---|
| 0 | DSP TEST | DSP bus access test mode. (Defaults to '0'. Do not over-write with different value) |
| 1 | STG[0] | Sidetone gain. See table below |
| 2 | STG[1] | |
| 3 | STG[2] | |
| 4 | STG[3] | |
| 5-7 | - | UNUSED (Don't care) |

| RXHFP[2:0] | -3dB Frequency (Hz) |
|------------|---------------------|
| 000 | 0 |
| 001 | 40 |
| 010 | 100 |
| 011 | 150 |
| 100 | 200 |
| 101 | 300 |
| 110 | 400 |
| 111 | Invalid |

| STG[3:0] | GAIN (dB) | STG[3:0] | GAIN (dB) |
|----------|-----------|----------|-----------|
| 0000 | -39 | 1000 | -15 |
| 0001 | -36 | 1001 | -12 |
| 0010 | -33 | 1010 | -9 |
| 0011 | -30 | 1011 | -6 |
| 0100 | -27 | 1100 | -3 |
| 0101 | -24 | 1101 | 0 |
| 0110 | -21 | 1110 | +3 |
| 0111 | -18 | 1111 | +6 |

| Address 08h/09h Write only | | Codec: DSP Test (Registers x2) |
|-------------------------------|-------------|---|
| 0 | DSPTTEST[0] | LOOPBACK (digital-to-digital). '0' for normal operation, '1' for loopback |
| 1 | DSPTTEST[1] | RESERVED (Defaults to '0'. Do not over-write with different value) |
| 2 | DSPTTEST[2] | RESERVED (Defaults to '0'. Do not over-write with different value) |
| 3-7 | - | UNUSED (Don't care) |

| Address 0Ah - 0Bh Read/Write | | Audio Interface: TX Gain (Registers x2) |
|---------------------------------|--------|---|
| 0 | TXG[0] | Programmable TX gain 0 to +46.5dB in 1.5dB steps. See table below TXG[4] controls whether or not the 'pre-amp' is used |
| 1 | TXG[1] | |
| 2 | TXG[2] | |
| 3 | TXG[3] | |
| 4 | TXG[4] | |
| 5-7 | - | UNUSED (Don't care) |

| TXG[4:0] | GAIN dB | TXG[4:0] | GAIN dB | TXG[4:0] | GAIN dB | TXG[4:0] | GAIN dB |
|----------|------------|----------|------------|----------|------------|----------|------------|
| 00000 | 0 | 01000 | 12 | 10000 | 24 | 11000 | 36 |
| 00001 | 1.5 | 01001 | 13.5 | 10001 | 25.5 | 11001 | 37.5 |
| 00010 | 3 | 01010 | 15 | 10010 | 27 | 11010 | 39 |
| 00011 | 4.5 | 01011 | 16.5 | 10011 | 28.5 | 11011 | 40.5 |
| 00100 | 6 | 01100 | 18 | 10100 | 30 | 11100 | 42 |
| 00101 | 7.5 | 01101 | 19.5 | 10101 | 31.5 | 11101 | 43.5 |
| 00110 | 9 | 01110 | 21 | 10110 | 33 | 11110 | 45 |
| 00111 | 10.5 | 01111 | 22.5 | 10111 | 34.5 | 11111 | 46.5 |

| Address 0Ch - 0Fh Read/Write | | Audio Interface: RX Analog Gain and Electret Bias (Registers x4) |
|---------------------------------|--------|---|
| 0 | RXG[0] | Programmable RX 'analog' gain -28dB to +2.0dB in 2dB steps (available for all four Audio Interfaces). See table below |
| 1 | RXG[1] | |
| 2 | RXG[2] | Register for Audio Interface #0 also defines 'AUXTONE' gain between -29dB and 0dB in approximate 2dB steps. See table below |
| 3 | RXG[3] | |
| 4 | EB[0] | Programmable Electret Microphone Bias 0V to 2.52V in 168mV steps. See table below Available for Audio Interfaces #3, #2 and #0 |
| 5 | EB[1] | |
| 6 | EB[2] | |
| 7 | EB[3] | |

| RXG [3:0] | GAIN (dB) | RXG [3:0] | GAIN (dB) |
|-----------|-----------|-----------|-----------|
| 0000 | -28 | 1000 | -12 |
| 0001 | -26 | 1001 | -10 |
| 0010 | -24 | 1010 | -8 |
| 0011 | -22 | 1011 | -6 |
| 0100 | -20 | 1100 | -4 |
| 0101 | -18 | 1101 | -2 |
| 0110 | -16 | 1110 | 0 |
| 0111 | -14 | 1111 | +2 |

RX 'Analog' Gain

| RXG0 [3:0] | AUX GAIN (dB) | RXG0 [3:0] | AUXGAIN (dB) |
|------------|---------------|------------|--------------|
| 0000 | -29 | 1000 | -13.2 |
| 0001 | -27 | 1001 | -11.2 |
| 0010 | -25 | 1010 | -9.3 |
| 0011 | -23 | 1011 | -7.4 |
| 0100 | -21.1 | 1100 | -5.5 |
| 0101 | -19.1 | 1101 | -3.6 |
| 0110 | -17.1 | 1110 | -1.8 |
| 0111 | -15.1 | 1111 | 0 |

#0 AUXTONE Gain

| EB [3:0] | Bias V | EB [3:0] | Bias V |
|----------|--------|----------|--------|
| 0000 | 0.00 | 1000 | 1.34 |
| 0001 | 0.17 | 1001 | 1.51 |
| 0010 | 0.34 | 1010 | 1.68 |
| 0011 | 0.50 | 1011 | 1.85 |
| 0100 | 0.67 | 1100 | 2.02 |
| 0101 | 0.84 | 1101 | 2.18 |
| 0110 | 1.01 | 1110 | 2.35 |
| 0111 | 1.18 | 1111 | 2.52 |

Electret Bias

| Address 10h Read/Write | | Audio Interface: Enable (Register x1) |
|---------------------------|------------|---|
| 0 | EN_AUDIO_0 | Enable Audio Interfaces (RX 'analog' circuitry, Electret bias, Microphone detect, Auxtone) |
| 1 | EN_AUDIO_1 | |
| 2 | EN_AUDIO_2 | |
| 3 | EN_AUDIO_3 | |
| 4 | EN_VREF | Enable Voltage Reference (needed for all analog functions) |
| 5 | EN_TX0 | Enable TX 'analog' circuitry. Also initiates the 'TX offset correction' routine. Important Note: There are several requirements which must be met before this routine can operate correctly. See explanation in section 'Automatic DC Offset Cancellation (TX)' |
| 6 | EN_TX1 | |
| 7 | - | UNUSED (Don't care) |

| Address 11h Read/Write | | Cross-Point: Selection (Register x1) |
|---------------------------|-------------|---|
| 0 | XP0[0] | Route Codec #0 to Audio Interface #0 to #3 e.g. XP0[1:0] = 01 = Audio Interface #1 (may be overridden by EN_AUXTONE) |
| 1 | XP0[1] | |
| 2 | XP1[0] | Route Codec #1 to Audio Interface #0 to #3 e.g. XP1[1:0] = 11 = Audio Interface #3 (may be overridden by EN_AUXTONE) |
| 3 | XP1[1] | |
| 4 | CON_CODEC_0 | Connect Codec #0 to the Cross-Point |
| 5 | CON_CODEC_1 | Connect Codec #1 to the Cross-Point |
| 6 | EN_AUXTONE | Route AUXTONE to Loud Speaker Outputs (Audio Interface #0). Overrides XP0/1 |
| 7 | 0 | RESERVED for Cross-Point Test Access (Defaults to zero. Do not change) |

| Address 12h/13h Read/Write | | PCM Interface: Codec Channel Allocation (Register x2) |
|-------------------------------|---------|--|
| 0 | CHAN[0] | Codec-Channel Allocation ST-Bus mode: (0 to 31) e.g. CHAN[4:0] = 01110 = Channel 14 GCI mode: (0 to 7) e.g. CHAN[4:0] = XX110 = Channel 6 SSI mode: ignored |
| 1 | CHAN[1] | |
| 2 | CHAN[2] | |
| 3 | CHAN[3] | |
| 4 | CHAN[4] | |
| 5-7 | - | UNUSED (Don't care) |

| Address 14h Read/Write | | PCM Interface: Status Channel Allocation (Register x1) |
|---------------------------|---------|---|
| 0 | CHAN[0] | Status-Channel Allocation ST-Bus mode: (0 to 31) e.g. CHAN[4:0] = 01110 = Channel 14 GCI mode: (0 to 7) e.g. CHAN[4:0] = XX110 = Channel 6 SSI mode: ignored |
| 1 | CHAN[1] | |
| 2 | CHAN[2] | |
| 3 | CHAN[3] | |
| 4 | CHAN[4] | |
| 5-7 | - | UNUSED (Don't care) |

| Address 15h Read/Write | | General: Mode Control (Register x1) |
|---------------------------|--------------|---|
| 0 | PCM_BUS[0] | Selects PCM Data Interface 00 = ST-Bus, 01 = GCI, 10 = SSI |
| 1 | PCM_BUS[1] | |
| 2 | MUTEMODE3[0] | Audio Interface #3: Mic Mute mode control (see section 'Microphone Mute Detect' and table below) |
| 3 | MUTEMODE3[1] | |
| 4 | MUTEMODE2[0] | Audio Interface #2: Mic Mute mode control (see section 'Microphone Mute Detect' and table below) |
| 5 | MUTEMODE2[1] | |
| 6 | MUTE[0] | Software mute for Audio Interface #0 |
| 7 | MUTE[1] | Software mute for Audio Interface #1 |

| MUTEMODE[1:0] | Mute Operation (see Figure 9) |
|---------------|---|
| 00 | Microphone path enabled (normal operation). 'Mic Mute Detect' signal ignored |
| 01 | Microphone path disabled (muted) while 'Mic Mute Detect' signal is high, and enabled while low |
| 10 | Microphone path disabled (muted) while 'Mic Mute Detect' signal is high, but must be re-enabled by the external controller |
| 11 | Microphone path disabled (muted). 'Mic Mute Detect' signal ignored |

| Address 16h Read/Write | | General: System Clock Frequency, PLL and Software Reset (Register x1) |
|---------------------------|----------|--|
| 0 | FREQ[0] | System Clock frequency, 'SYSCLK'. See table below Note: Some frequencies need the internal PLL to be enabled |
| 1 | FREQ[1] | |
| 2 | FREQ[2] | |
| 3 | EN_PLL | Enable PLL (only required for some SYSCLK frequencies). Allow 1ms to settle |
| 4 | SW_RESET | 'Software Reset' - see explanation in section 'System Reset Options' |
| 5-7 | - | UNUSED (Don't care) |

| FREQ [2:0] | System Clock (MHz) | Clocking Method | PLL Multiplier |
|------------|--------------------|------------------------------|----------------|
| 000 | 20.48 | Direct (PLL output not used) | x10 |
| 001 | 20.0 | Direct (PLL output not used) | x5 |
| 010 | 25.0 | Direct (PLL output not used) | x2 |
| 011 | 50.0 | Direct (PLL output not used) | x2 |
| 100 | 2.048 | Internal PLL | x10 |
| 101 | 4.096 | Internal PLL | x5 |
| 110 | 10.24 | Internal PLL | x2 |
| 111 | 10.24 (spare) | Internal PLL | x2 |

| Address 17h Read/Write | | General: Test (Register x1) [‡] |
|---------------------------|-----------|---|
| 0 | TEST[1:0] | RESERVED [‡] for 'gemulation mode' testing |
| 1 | | |
| 2 | TEST[3:2] | RESERVED [‡] for internal signal testing via DTSSO pin. 01 = Internal SYSCLK (PLL output in some modes) |
| 3 | | |
| 4 | 0 | RESERVED [‡] |
| 5 | 0 | |
| 6 | 0 | |
| 7 | 0 | |

[‡]Defaults to all-zero's. Do not over-write with different values

| Address 18h Read/Write | | General: Test TX Analog (Register x1) [‡] |
|---------------------------|--------|--|
| 0 | PDVC | RESERVED [‡] for production testing |
| 1 | PDSO | |
| 2 | PDDAC | |
| 3 | TCALVG | |
| 4 | TCALMA | |
| 5 | TSTVG | |
| 6 | TSTAA | |
| 7 | - | |

| Address 19h Read only | | Audio Interface: Status (Register x1) |
|--------------------------|----------|--|
| 0 | MUTEDET3 | Audio Interface #3: 'Mic Mute Detect' signal |
| 1 | MUTE3 | Audio Interface #3: Microphone Channel is Muted (may need to be actively un-muted) |
| 2 | MUTEDET2 | Audio Interface #2: 'Mic Mute Detect' signal |
| 3 | MUTE2 | Audio Interface #2: Microphone Channel is Muted (may need to be actively un-muted) |
| 4 | MIC3 | Audio Interface #3: 'Mic Presence Detect' signal |
| 5 | MIC2 | Audio Interface #2: 'Mic Presence Detect' signal |
| 6-7 | - | UNUSED (Don't care) |

AC/DC Electrical Characteristics

Absolute Maximum Ratings[‡]

| Characteristics | Min | Max | Units | Comments |
|------------------------------------|------|------|-------|-------------|
| Storage Temperature | -55 | +150 | degC | |
| Supply Voltage | -0.3 | 5.0 | V | < 2 minutes |
| | -0.3 | 3.6 | V | Continuous |
| Pin voltage relative to VDD | | +0.3 | V | |
| Pin voltage relative to GND or SUB | -0.3 | | V | |

[‡] Exceeding these values may cause permanent damage. Functional operation under these conditions is not implied.

Recommended Operating Conditions

| Characteristics | Min | Max | Units | Comments |
|---------------------|-----|-----|-------|----------|
| Ambient Temperature | -40 | +85 | °C | |
| Supply Voltage Vdd | 3.0 | 3.6 | V | |

General Characteristics

| Characteristics | Min | Typ [‡] | Max | Units | Comments |
|---------------------------------|---------|------------------|-----|-------|----------------------------|
| Supply Current | | 13 | 23 | mA | Operating. No output loads |
| | | | 10 | uA | Powered down |
| Digital Inputs: lower threshold | | | 0.8 | V | |
| Digital Inputs: upper threshold | 2.0 | | | V | |
| Digital Outputs: lower level | | | 0.4 | V | Sinking 6mA |
| Digital Outputs: upper level | 0.8*VDD | | | | Sourcing 6mA |

[‡] Typical figures are at 25°C and are for design aid only: not guaranteed and not subject to production testing.

RX Path Characteristics - All parameters are measured differentially between the 'EARP' and 'EARN' pins. DSP gain is set to 0dB unless otherwise stated.

| Characteristics | Min | Typ [‡] | Max | Units | Comments |
|--|-------|------------------|-------|--------|--|
| Output level for 0dBm0 | 0.955 | 1.012 | 1.071 | V rms | Analog gain set to 0dB |
| | | 40.3 | | mV rms | Analog gain set to -28dB |
| Driver output power | 66 | | | mW rms | 1kHz sinewave, <1% THD, 32 Ohm load |
| Speaker output power (Audio Interface #0 only) | 150 | | | mW rms | 1kHz sinewave, <1% THD, 16 Ohm load |
| Analog gains | | -28 to +2 | | dB | 16 gain values available |
| Analog gain error | -0.2 | 0 | +0.2 | dB | Analog gain -28dB to +2dB, 1kHz, 0dBm0 |
| Analog gain step size | | 2 | | dB | |
| Idle channel noise | | | -70 | dBm0p | Measured at gain -28dB and +2dB |
| DC offset voltage | -50 | | +50 | mV | Analog gain 0dB |

[‡] Typical figures are at 25°C and are for design aid only: not guaranteed and not subject to production testing.

AUXTONE Path Characteristics - All parameters are measured differentially between the 'EAR0P/SPEAKERP' and 'EAR0N/SPEAKERN' pins unless otherwise stated.

| Characteristics | Min | Typ [‡] | Max | Units | Comments |
|-------------------------------|------|------------------|------|-------|--------------------------|
| Gain | | -29 to 0 | | dB | 16 gain values available |
| Gain step size | | 2 | | dB | Step sizes not all equal |
| Maximum gain setting | -0.5 | 0 | +0.5 | dB | 1kHz, 1V rms sinewave |
| Input DC bias | | VDD/2 | | V | AUXTONE input |
| AUXTONE input resistance (AC) | | 111.5 | | kOhms | Minimum gain setting |
| | | 57.7 | | kOhms | Maximum gain setting |

‡ Typical figures are at 25°C and are for design aid only: not guaranteed and not subject to production testing.

TX Path Characteristics - All parameters are referred to the differential signal between the 'MICP' and 'MICN' pins unless otherwise stated.

| Characteristics | Min | Typ [‡] | Max | Units | Comments |
|---------------------------------|-------|------------------|-------|--------|--|
| Input level for 0dBm0 | 0.577 | 0.611 | 0.647 | V rms | Gain set to 0dB |
| | | 2.89 | | mV rms | Gain set to 46.5dB |
| Input common-mode bias | | VDD/2 | | V | DC bias on each input, relative to GND |
| Input resistance (AC) | | 107 | | kOhms | Gain 0dB to 10.5dB |
| | | 54 | | kOhms | Gain 12dB to 22.5dB |
| | | 80 | | kOhms | Gain 24dB to 46.5dB |
| Gains | | 0 to +46.5 | | dB | 32 gain values available |
| Gain error | -0.2 | 0 | +0.2 | dB | Gain 0dB to 22.5dB, 1kHz, 0dBm0 |
| | -0.3 | 0 | +0.3 | dB | Gain 24dB to 46.5dB, 1kHz, 0dBm0 |
| Gain step size | | 1.5 | | dB | |
| Input referred noise 300-3400Hz | | 20 | | uV rms | Gain set to Minimum |
| | | -90 | | dBm0 | |
| | | 5 | | uV rms | Gain set to Maximum |
| | | -55 | | dBm0 | |

‡ Typical figures are at 25°C and are for design aid only: not guaranteed and not subject to production testing.

Electret Bias, Mic Presence and Mic Mute Detect Characteristics - All Electret Bias parameters measured at the MICBIAS pin relative to GND. All Detect parameters measured at the MICDETECT pin relative to GND.

| Characteristics | Min | Typ [‡] | Max | Units | Comments |
|---------------------------------------|------------------------|------------------|------------------------|--------|------------------------------------|
| Electret bias voltage 'EBV' | | 0.0 to 2.52 | | V | 16 levels available |
| | 0.9 * Typ | 2.52 * N / 15 | 1.1 * Typ | V | N = 0 to 15 |
| Output noise | | 25 | | uV rms | 300-3400Hz |
| Drive current capability | 1 | | | mA | Source current |
| Output resistance | | 0.5 | | Ohms | At 1kHz |
| Supply rejection | | 60 | | dB | At 1kHz |
| | | | | | |
| 'Presence' detect threshold (rising) | 0.97 * Typ +/- 10mV | 0.04 * EBV | 1.03 * Typ +/- 10mV | V | Derived from electret bias voltage |
| 'Presence' detect threshold (falling) | | 0.03 * EBV | | | |
| | | | | | |
| 'Mute' detect threshold (rising) | 0.97 * Typ +/- 10mV | 0.45 * EBV | 1.03 * Typ +/- 10mV | V | Derived from electret bias voltage |
| 'Mute' detect threshold (falling) | | 0.35 * EBV | | | |

‡ Typical figures are at 25°C and are for design aid only: not guaranteed and not subject to production testing.

TX/RX/TX Crosstalk Characteristics

| Characteristics | Min | Typ | Max | Units | Comments |
|--------------------------|-----|-----|-----|-------|----------|
| Analog-TX to Analog-RX | | | -73 | dBm0 | |
| Analog-TX to Digital-TX | | | -70 | dBm0 | |
| Digital-RX to Analog-RX | | | -70 | dBm0 | |
| Digital-RX to Digital-TX | | | -70 | dBm0 | |

PCM Serial Data Interface Timings (ST-Bus)

| Characteristics | Sym | Min | Typ | Max | Units | Test Notes |
|--|--------------------|-------|-------|-------|-------|-------------|
| $\overline{C4i}$ Period | t_{C4P} | 243.9 | 244.1 | 244.4 | ns | |
| $\overline{C4i}$ /DCL/SCK Clock High | t_{SCH}, t_{C4H} | 90 | | | ns | |
| $\overline{C4i}$ /DCL/SCK Clock Low | t_{SCL}, t_{C4L} | 90 | | | ns | |
| $\overline{F0i}$ / FSC Setup | t_{F0iS} | 20 | | 150 | ns | |
| $\overline{F0i}$ / FSC Hold | t_{F0iH} | 20 | | 150 | ns | |
| ST-BUS/GCI Data Input Hold time | t_{DSH} | 20 | | | ns | |
| ST-BUS/GCI Data Input Setup time | t_{DSS} | 20 | | | ns | |
| ST-BUS/GCI Data Output delay | t_{DSD} | | | 80 | ns | $C_L=150pF$ |
| ST-BUS/GCI Output Active to High Impedance | t_{ASHZ} | | | 80 | ns | $C_L=150pF$ |

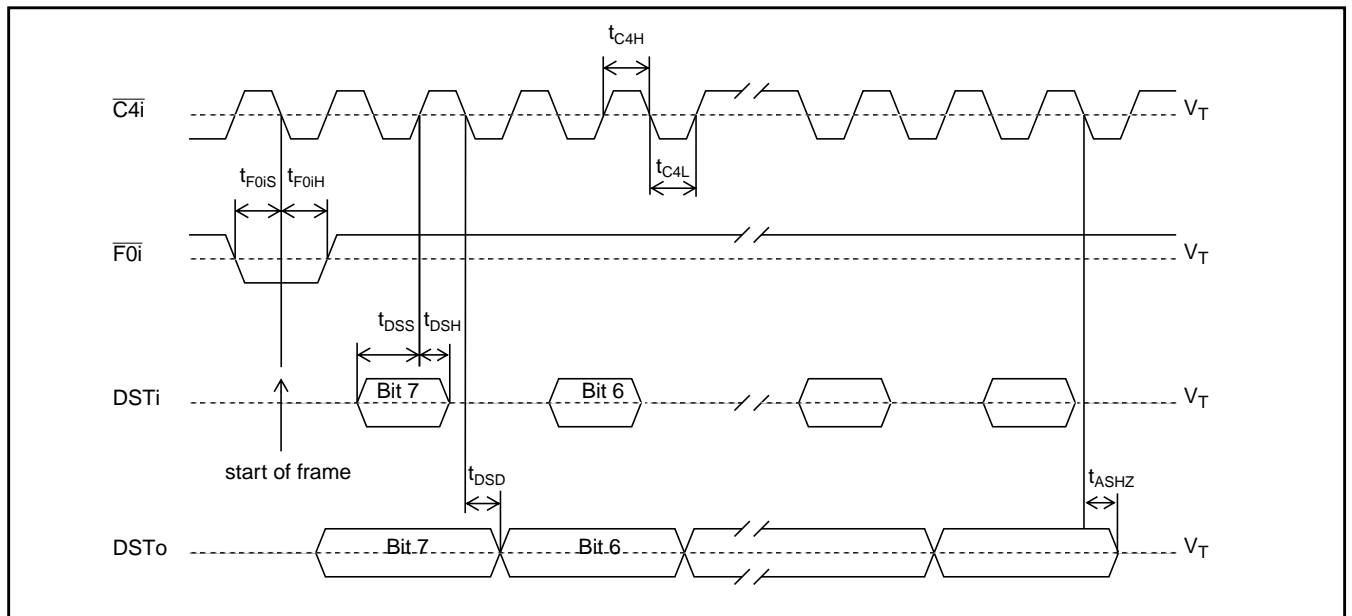

Figure 17 - ST-Bus Data Port Timing

PCM Serial Data Interface Timings (GCI)

| Characteristics | Sym | Min | Typ | Max | Units | Test Notes |
|--|--------------------|-----|-----|-----|-------|-------------|
| DCL Period | t_{CKP} | 244 | | 651 | ns | |
| $\overline{C4i}$ /DCL/SCK Clock High | t_{SCH}, t_{C4H} | 90 | | | ns | |
| $\overline{C4i}$ /DCL/SCK Clock Low | t_{SCL}, t_{C4L} | 90 | | | ns | |
| $\overline{F0i}$ / FSC Setup | t_{F0iS} | 20 | | 150 | ns | |
| $\overline{F0i}$ / FSC Hold | t_{F0iH} | 20 | | 150 | ns | |
| ST-BUS/GCI Data Input Hold time | t_{DSH} | 20 | | | ns | |
| ST-BUS/GCI Data Input Setup time | t_{DSS} | 20 | | | ns | |
| GCI FSC to Data Delay (first bit) | t_{SD} | | | 80 | ns | $C_L=150pF$ |
| ST-BUS/GCI Data Output delay | t_{DSD} | | | 80 | ns | $C_L=150pF$ |
| ST-BUS/GCI Output Active to High Impedance | t_{ASHZ} | | | 80 | ns | $C_L=150pF$ |

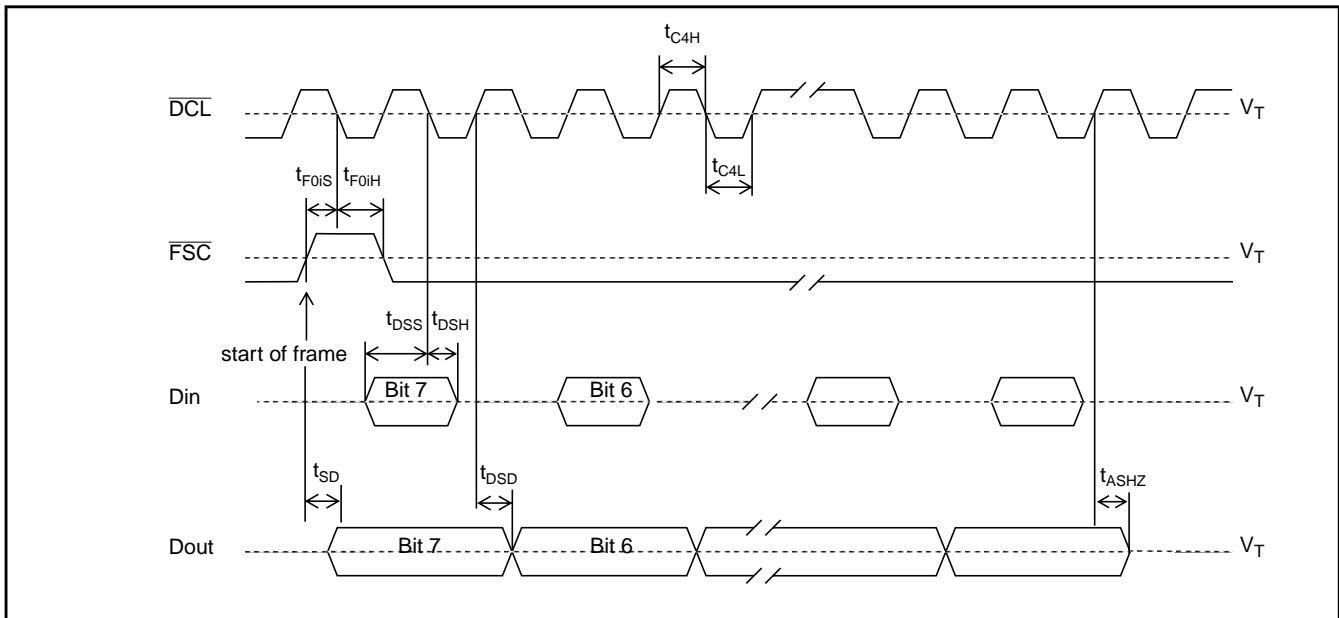

Figure 18 - GCI Data Port Timing

PCM Serial Data Interface Timings (SSI)

| Characteristics | Sym | Min | Typ | Max | Units | Test Notes |
|---|--------------------|-----|-----|--------------|-------|-------------|
| SCK Period | t_{SCP} | 244 | | 1953 | ns | |
| $\overline{C4i}/DCL/SCK$ Clock High | t_{SCH}, t_{C4H} | 90 | | | ns | |
| $\overline{C4i}/DCL/SCK$ Clock Low | t_{SCL}, t_{C4L} | 90 | | | ns | |
| SSI Enable Strobe to Data Delay (first bit) | t_{SD} | | | 80 | ns | $C_L=150pF$ |
| SSI Data Output Delay (excluding first bit) | t_{DD} | | | 80 | ns | $C_L=150pF$ |
| SSI Output Active to High Impedance | t_{AHZ} | | | 80 | ns | $C_L=150pF$ |
| SSI Enable Strobe Signal Setup | t_{SS} | 70 | | t_{SCP} | ns | |
| SSI Enable Strobe Signal Hold | t_{SH} | 15 | | $t_{SCP}-10$ | ns | |
| SSI Data Input Setup | t_{SDS} | 10 | | | ns | |
| SSI Data Input Hold | t_{SDH} | 15 | | | ns | |

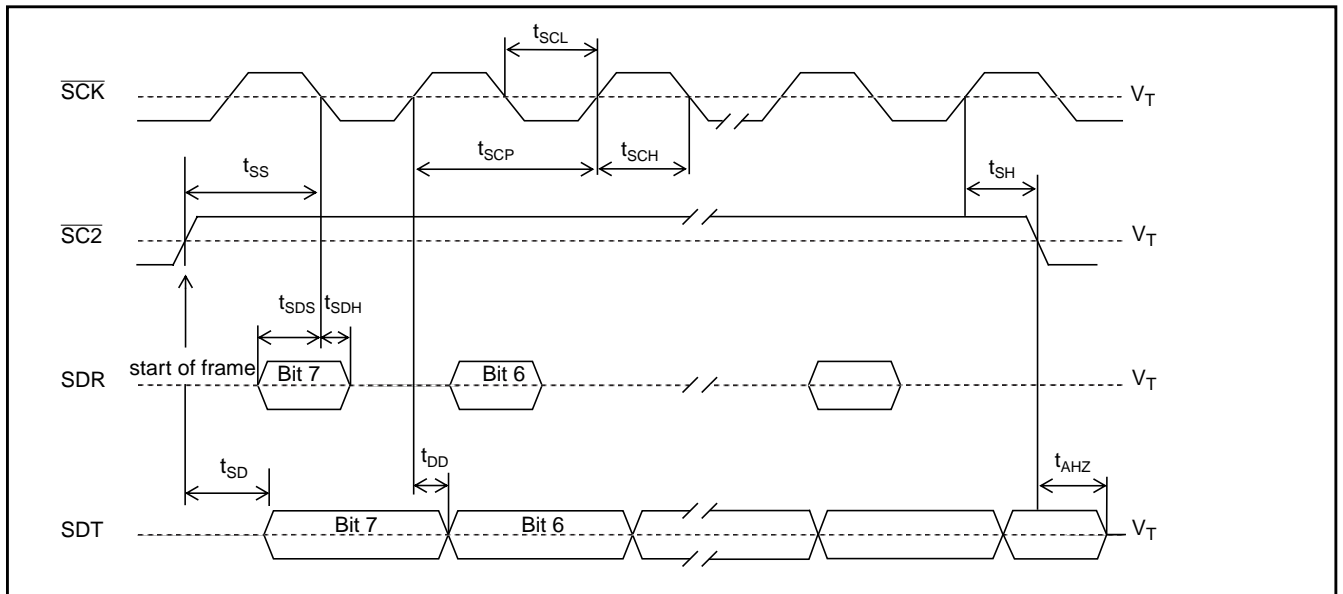

Figure 19 - SSI Data Port Timing

Microport Timings

| Characteristics | Sym | Min | Typ | Max | Units | Test Notes |
|--|------------|-----|-----|-----|-------|-------------|
| Input Data Setup | t_{IDS} | 100 | | | ns | |
| Input Data Hold | t_{IDH} | 30 | | | ns | |
| Output Data Delay | t_{ODD} | | | 100 | ns | $C_L=150pF$ |
| Serial Clock Period | t_{SCP} | 500 | | | ns | |
| SCLK Pulse Width High | t_{SCH} | 250 | | | ns | |
| SCLK Pulse Width Low | t_{SCL} | 250 | | | ns | |
| \overline{CS} Setup-Intel | t_{CSSI} | 200 | | | ns | |
| \overline{CS} Setup-Motorola | t_{CSSM} | 100 | | | ns | |
| \overline{CS} Hold | t_{CSH} | 100 | | | ns | |
| \overline{CS} to Output High Impedance | t_{OHZ} | | | 100 | ns | $C_L=150pF$ |

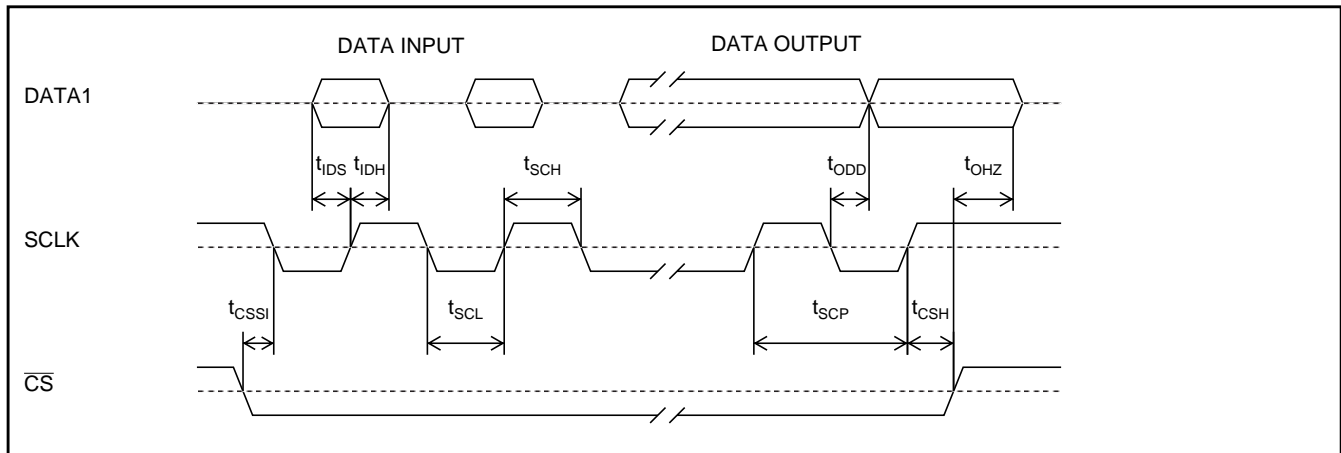

Figure 20 - INTEL Serial Microport Timing

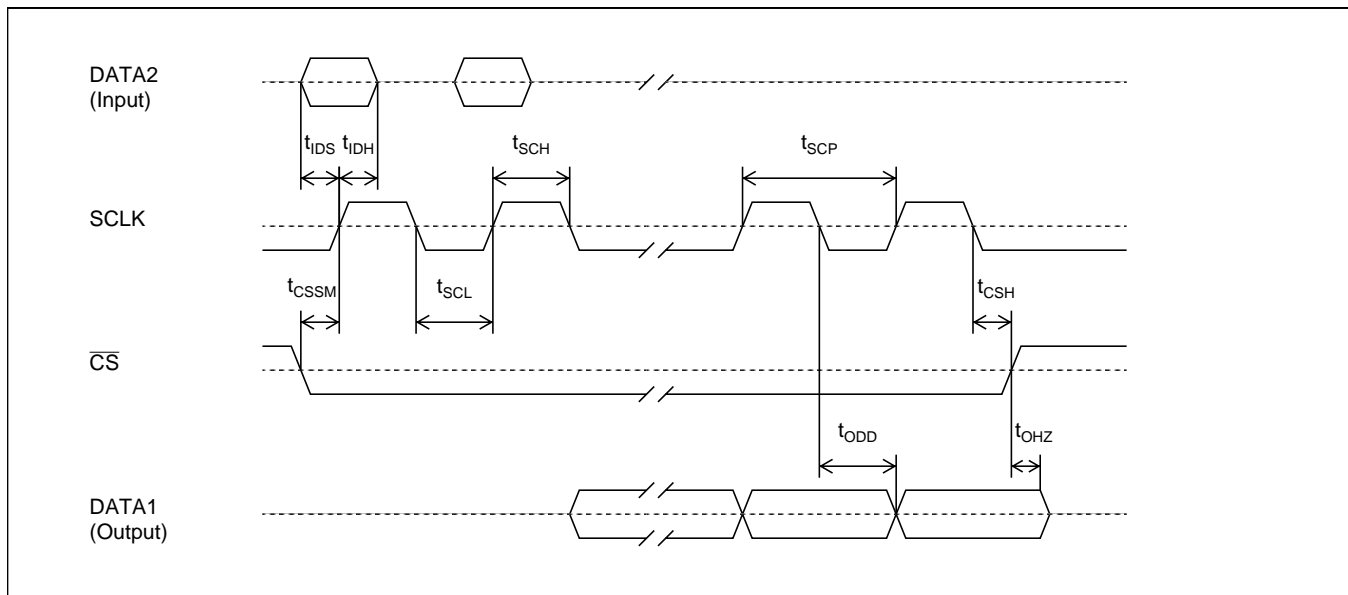

Figure 21 - Motorola/National Serial Microport Timing

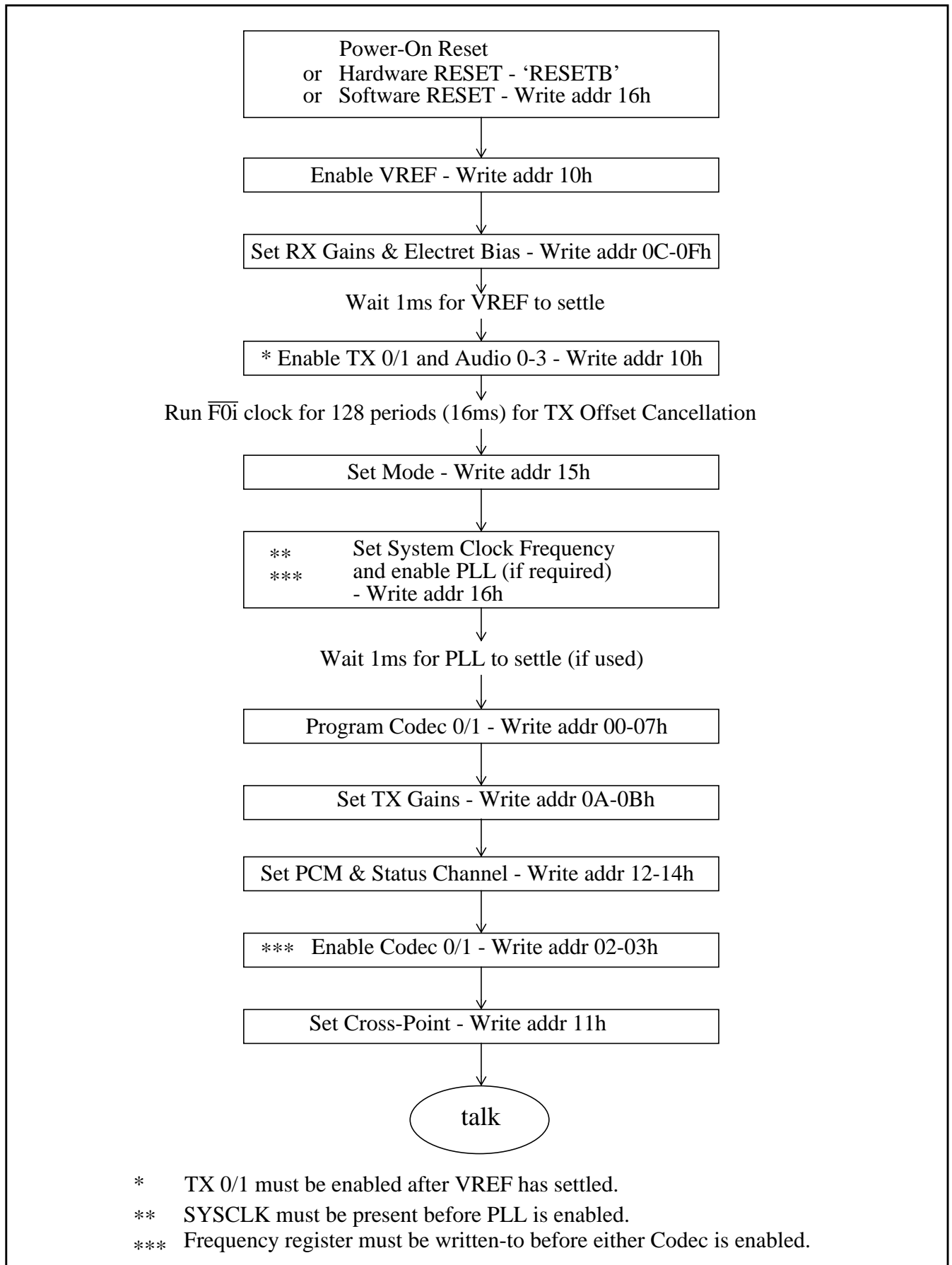
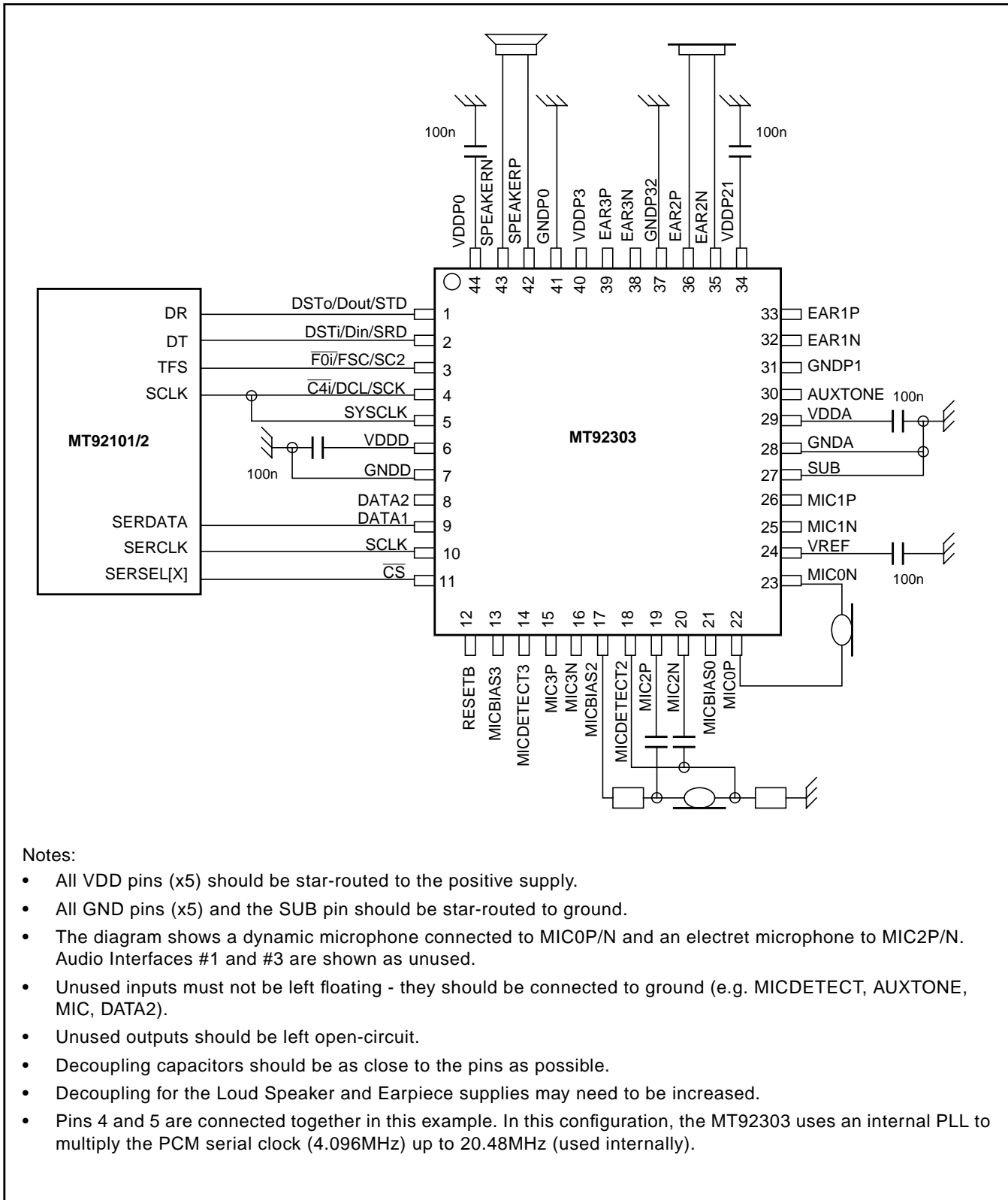

Figure 22 - Suggested Microport Programming Sequence



Notes:

- All VDD pins (x5) should be star-routed to the positive supply.
- All GND pins (x5) and the SUB pin should be star-routed to ground.
- The diagram shows a dynamic microphone connected to MIC0P/N and an electret microphone to MIC2P/N. Audio Interfaces #1 and #3 are shown as unused.
- Unused inputs must not be left floating - they should be connected to ground (e.g. MICDETECT, AUXTONE, MIC, DATA2).
- Unused outputs should be left open-circuit.
- Decoupling capacitors should be as close to the pins as possible.
- Decoupling for the Loud Speaker and Earpiece supplies may need to be increased.
- Pins 4 and 5 are connected together in this example. In this configuration, the MT92303 uses an internal PLL to multiply the PCM serial clock (4.096MHz) up to 20.48MHz (used internally).

Figure 23 - Application Diagram

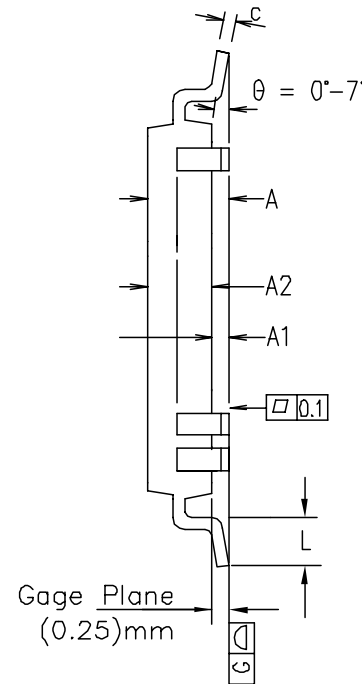
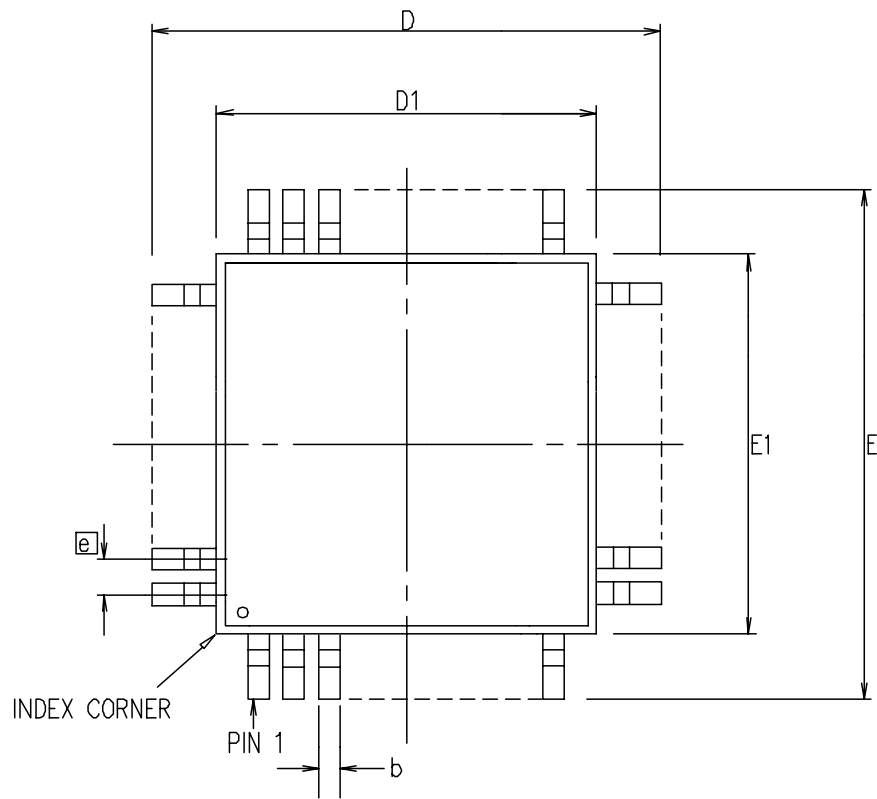

| Symbol | Control Dimensions in millimetres | | Altern. Dimensions in inches | |
|--------------|--------------------------------------|------|---------------------------------|-------|
| | MIN | MAX | MIN | MAX |
| A | — | 2.45 | — | 0.096 |
| A1 | 0.00 | 0.25 | 0.000 | 0.010 |
| A2 | 1.80 | 2.20 | 0.071 | 0.087 |
| D | 13.20 | BSC | 0.520 | BSC |
| D1 | 10.00 | BSC | 0.394 | BSC |
| E | 13.20 | BSC | 0.520 | BSC |
| E1 | 10.00 | BSC | 0.394 | BSC |
| L | 0.73 | 1.03 | 0.029 | 0.041 |
| e | 0.80 | BSC. | 0.031 | BSC. |
| b | 0.29 | 0.45 | 0.011 | 0.018 |
| c | 0.11 | 0.23 | 0.004 | 0.009 |
| Pin features | | | | |
| N | 44 | | | |
| ND | 11 | | | |
| NE | 11 | | | |
| NOTE | SQUARE | | | |

Conforms to JEDEC MS-022 AB-1 Iss. B

Notes:

1. Pin 1 indicator may be a corner chamfer, dot or both.
2. Controlling dimensions are in millimeters.
3. The top package body size may be smaller than the bottom package body size by a max. of 0.15 mm.
4. Dimension D1 and E1 do not include mould protusion.
5. Dimension b does not include dambar protusion.
6. Coplanarity, measured at seating plane G, to be 0.010 mm max.

© Mitel (1999) All rights reserved.

ORIGINATING SITE: SWINDON

| ISSUE | 1 | 2 | 3 | | |
|-------|---------|---------|---------|--|--|
| ACN | 201346 | 205424 | 207059 | | |
| DATE | 25OCT96 | 22OCT98 | 29JUN99 | | |
| APPD. | | | | | |

MITEL SEMICONDUCTOR

Title: Package Outline Drawing for low stand-off
44L MQFP (GP)
(10x10x2.0) mm, Body+3.2 mm

Drawing Number

GPD00231



<http://www.mitelsemi.com>

World Headquarters - Canada

Tel: +1 (613) 592 2122
Fax: +1 (613) 592 6909

North America

Tel: +1 (770) 486 0194
Fax: +1 (770) 631 8213

Asia/Pacific

Tel: +65 333 6193
Fax: +65 333 6192

**Europe, Middle East,
and Africa (EMEA)**

Tel: +44 (0) 1793 518528
Fax: +44 (0) 1793 518581

Information relating to products and services furnished herein by Mitel Corporation or its subsidiaries (collectively "Mitel") is believed to be reliable. However, Mitel assumes no liability for errors that may appear in this publication, or for liability otherwise arising from the application or use of any such information, product or service or for any infringement of patents or other intellectual property rights owned by third parties which may result from such application or use. Neither the supply of such information or purchase of product or service conveys any license, either express or implied, under patents or other intellectual property rights owned by Mitel or licensed from third parties by Mitel, whatsoever. Purchasers of products are also hereby notified that the use of product in certain ways or in combination with Mitel, or non-Mitel furnished goods or services may infringe patents or other intellectual property rights owned by Mitel.

This publication is issued to provide information only and (unless agreed by Mitel in writing) may not be used, applied or reproduced for any purpose nor form part of any order or contract nor to be regarded as a representation relating to the products or services concerned. The products, their specifications, services and other information appearing in this publication are subject to change by Mitel without notice. No warranty or guarantee express or implied is made regarding the capability, performance or suitability of any product or service. Information concerning possible methods of use is provided as a guide only and does not constitute any guarantee that such methods of use will be satisfactory in a specific piece of equipment. It is the user's responsibility to fully determine the performance and suitability of any equipment using such information and to ensure that any publication or data used is up to date and has not been superseded. Manufacturing does not necessarily include testing of all functions or parameters. These products are not suitable for use in any medical products whose failure to perform may result in significant injury or death to the user. All products and materials are sold and services provided subject to Mitel's conditions of sale which are available on request.

M Mitel (design) and ST-BUS are registered trademarks of MITEL Corporation
Mitel Semiconductor is an ISO 9001 Registered Company
Copyright 1999 MITEL Corporation
All Rights Reserved
Printed in CANADA

TECHNICAL DOCUMENTATION - NOT FOR RESALE