



DM54L10 Triple 3-Input NAND Gates

General Description

This device contains three independent gates each of which performs the logic NAND function.

Connection Diagram

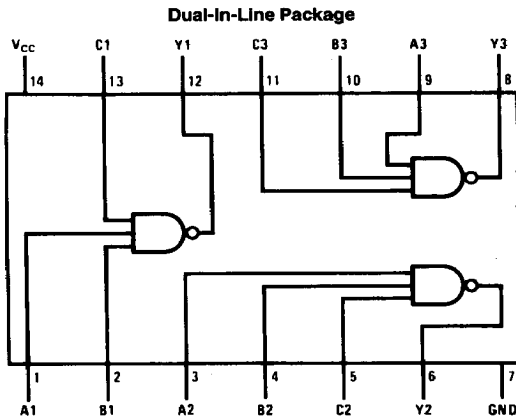

Order Number DM54L10J or DM54L10W
See NS Package Number J14A or W14B

TL/F/6619-1

Function Table

$$Y = \overline{ABC}$$

Inputs			Output
A	B	C	Y
X	X	L	H
X	L	X	H
L	X	X	H
H	H	H	L

H = High Logic Level
L = Low Logic Level
X = Either Low or High Logic Level

Absolute Maximum Ratings (Note)

If Military/Aerospace specified devices are required, please contact the National Semiconductor Sales Office/Distributors for availability and specifications.

Supply Voltage	8V
Input Voltage	5.5V
Operating Free Air Temperature Range DM54L	-55°C to +125°C
Storage Temperature Range	-65°C to +150°C

Note: The "Absolute Maximum Ratings" are those values beyond which the safety of the device cannot be guaranteed. The device should not be operated at these limits. The parametric values defined in the "Electrical Characteristics" table are not guaranteed at the absolute maximum ratings. The "Recommended Operating Conditions" table will define the conditions for actual device operation.

Recommended Operating Conditions

Symbol	Parameter	DM54L10			Units
		Min	Nom	Max	
V _{CC}	Supply Voltage	4.5	5	5.5	V
V _{IH}	High Level Input Voltage	2			V
V _{IL}	Low Level Input Voltage			0.7	V
I _{OH}	High Level Output Current			-0.2	mA
I _{OL}	Low Level Output Current			2	mA
T _A	Free Air Operating Temperature	-55		125	°C

Electrical Characteristics over recommended operating free air temperature (unless otherwise noted)

Symbol	Parameter	Conditions	Min	Typ (Note 1)	Max	Units
V _{OH}	High Level Output Voltage	V _{CC} = Min, I _{OH} = Max V _{IL} = Max	2.4	3.3		V
V _{OL}	Low Level Output Voltage	V _{CC} = Min, I _{OL} = Max V _{IH} = Min		0.15	0.3	V
I _I	Input Current @ Max Input Voltage	V _{CC} = Max, V _I = 5.5V			0.1	mA
I _{IH}	High Level Input Current	V _{CC} = Max, V _I = 2.4V			10	μA
I _{IL}	Low Level Input Current	V _{CC} = Max, V _I = 0.3V			-0.18	mA
I _{OS}	Short Circuit Output Current	V _{CC} = Max (Note 2)	-3		-15	mA
I _{CCH}	Supply Current with Outputs High	V _{CC} = Max		0.33	0.6	mA
I _{CCL}	Supply Current with Outputs Low	V _{CC} = Max		0.87	1.53	mA

Switching Characteristics at V_{CC} = 5V and T_A = 25°C (See Section 1 for Test Waveforms and Output Load)

Symbol	Parameter	Conditions	Min	Max	Units
t _{PLH}	Propagation Delay Time Low to High Level Output	R _L = 4 kΩ, C _L = 50 pF		60	ns
t _{PHL}	Propagation Delay Time High to Low Level Output			60	ns

Note 1: All typicals are at V_{CC} = 5V, T_A = 25°C.

Note 2: Not more than one output should be shorted at a time.