



A range of general purpose relays with 2 CO (DPDT) or 3 CO (3PDT) contacts

- 8 - 11 pin plug-in (FASTON) or solder versions available
- AC or DC coils
- Test button with mechanical flag indicator
- Can be used with supply status indication, coil protection and timer modules
- Rear DIN rail mount and bifurcated contact options
- Sockets and accessories: see 90 and 99 series and 86.60 timer modules
- Approvals (according to type): BBJ, BEAB, CSA, DEMKO, FIMKO, GOST, IMQ, NEMKO, RINA, SEV, cUL, VDE

WOOD-PROCESSING
MACHINES



INDUSTRIAL
APPLIANCES



ELEVATORS

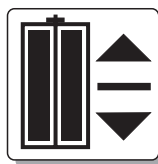

TOOLING
MACHINES



CERAMIC INDUSTRY
MACHINES

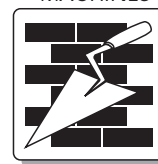

AUTOMATIC
GATES

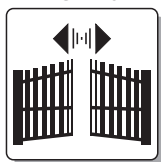

MEDICAL
EQUIPMENT



PLASTIC
MOULDING

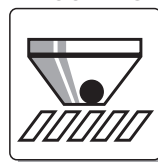

ON-BOARD SHIP
APPLIANCES





60.13



60.63



PLUG-IN 8/11 PIN RELAYS 10 A

TYPE 60.12 2 CO (DPDT) standard version available with test button and mechanical indicator

TYPE 60.13 3 CO (3PDT) standard version available with test button and mechanical indicator

TYPE 60.12 - 0200 2 CO (DPDT) 6 A bifurcated contacts

TYPE 60.13 - 0200 3 CO (3PDT) 6 A bifurcated contacts

- Single piece connection from contact to pin
- LED and diode available
- Standard contact material: AgNi
- Options: see coding table page 71
- Ordering information: see page 71

PLUG-IN RELAYS 10 A

TYPE 60.62 2 CO (DPDT)

TYPE 60.63 3 CO (3PDT)

- Cover with flanges for $\varnothing 3 \pm 0.3$ mm screw mount
- Tin plated copper connections: FASTON 187 (4.8 x 0.8 mm)
- Standard contact material: Ag Ni
- Options: see coding table page 71
- Ordering information: see page 71

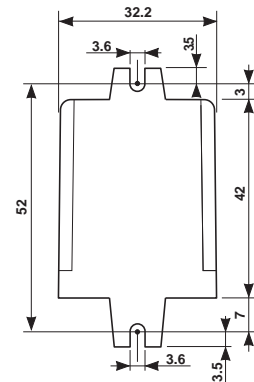
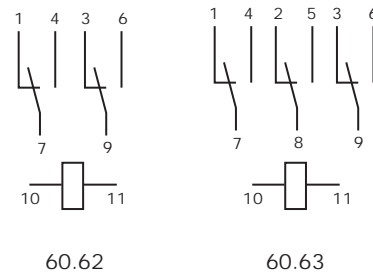
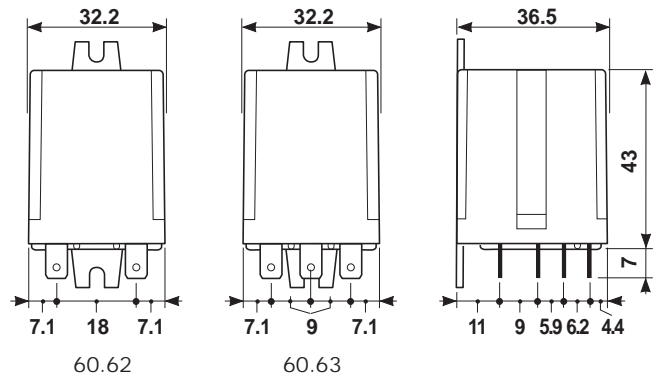
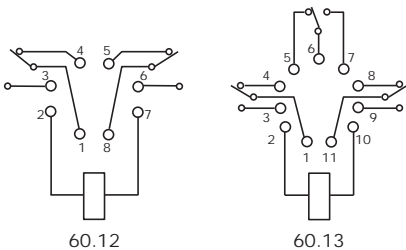
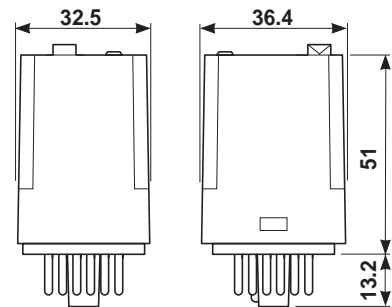

TECHNICAL DATA

DIELECTRIC STRENGTH tested at leakage current ≤ 10 mA for 1 min at 50 Hz	between coil and contacts	2,000 V
	between open contacts	1,000 V
	between adjacent contacts	2,000 V
	between frame and live parts	2,000 V
SURGE TEST (1.2/50 μs) between coil and contacts		2,500 V
ISOLATION RESISTANCE		≥ 20 · 10 ³ MΩ
ISOLATION GROUP		C 250
MAXIMUM SWITCHING FREQUENCY		
- without load		36,000 cycles/h
- at rated load		1,800 cycles/h
AMBIENT TEMPERATURE		(-40 ... +70)°C
MECHANICAL LIFE		20 · 10 ⁶ cycles version AC 50 · 10 ⁶ cycles version DC
PROTECTION CATEGORY OF ENCLOSURES		IP 40
OPERATE AND RELEASE TIME		
- pick-up time (0 to U _N)		≤ 15 ms (including contact bounce)
- drop-out time (U _N to 0)		≤ 15 ms (including contact bounce)
TYPE OF DUTY		continuous
DIELECTRIC TEST		
TYPE OF RELAY		all-or-nothing

CONTACT SPECIFICATIONS

RATED CURRENT	10 A
MAXIMUM PEAK CURRENT	20 A
NOMINAL RATE IN AC1	2,500 VA
NOMINAL RATE IN AC15	500 VA
RATED VOLTAGE	250 V AC
MAXIMUM SWITCHING VOLTAGE	400 V AC
BREAKING CAPACITY IN DC1	see diagram H 60
SINGLE PHASE HP MOTOR RATING	0.37 kW/0.6 HP
CONTACT RESISTANCE: - initial	≤ 50 mΩ
MINIMUM SWITCHING LOAD	500 mW (10 V/5 mA)
STANDARD CONTACT MATERIAL	AgNi

BIFURCATED CONTACTS (OPTION 0200)

RATED CURRENT	6 A
NOMINAL RATE IN AC1	1,500 VA
NOMINAL RATE IN AC15	250 VA
RATED VOLTAGE	250 V
MINIMUM SWITCHING LOAD	50 mW (5 V/5 mA)

F 60

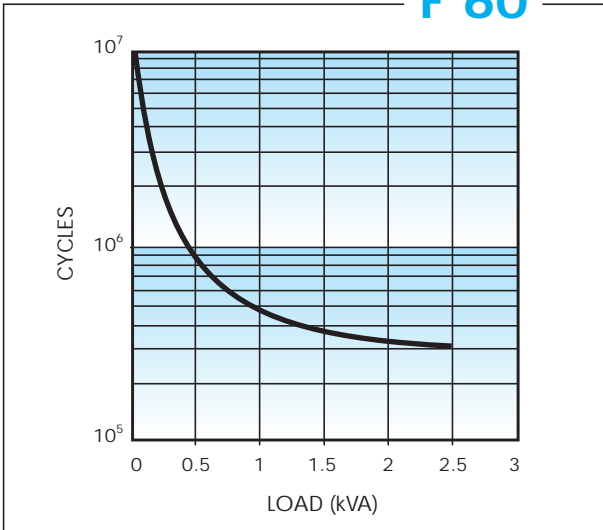

Contact life vs AC1 load at 1800 cycles/h.

H 60

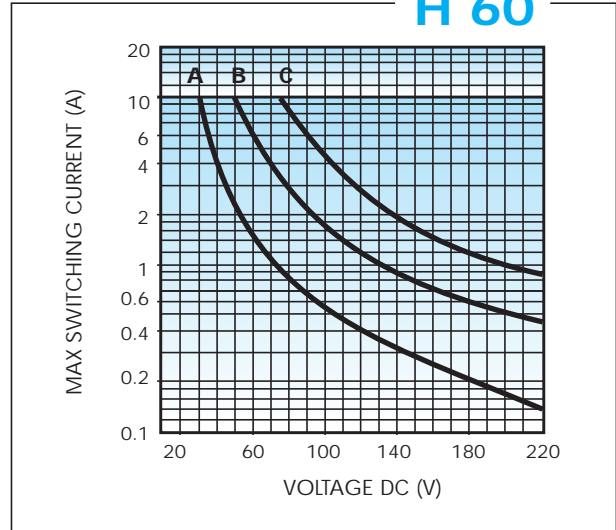

Breaking capacity for DC1 load at 1800 cycles/h.

- A** = load applied to 1 contact
- B** = load applied to 2 contacts in series
- C** = load applied to 3 contacts in series

K 60

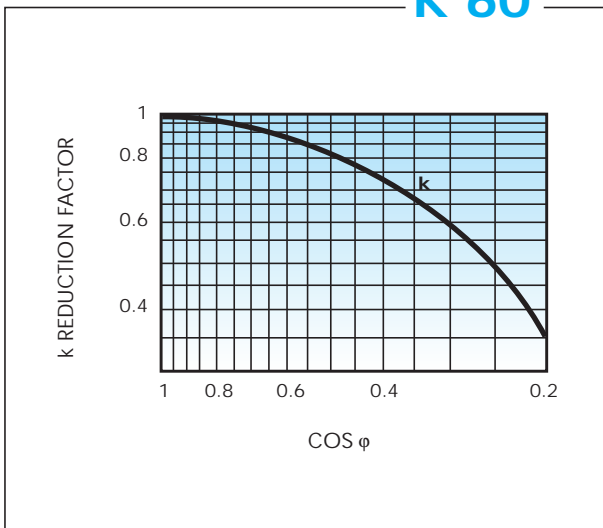

Load reduction factor vs cos φ.

COIL SPECIFICATIONS

VERSIONS:

- AC - alternating current 50/60 Hz
- DC - direct current
- AM - current sensing
- DI - DC coil with a diode in parallel

	AC	DC
RATED POWER	2.2 VA	1.3 W
OPERATING RANGE	(0.8 ... 1.1) U _N	(0.8 ... 1.1) U _N
HOLDING VOLTAGE	≤ 0.8 U _N	≤ 0.5 U _N
MUST DROP-OUT VOLTAGE	≥ 0.2 U _N	≥ 0.1 U _N
NOMINAL MAGNETOMOTIVE FORCE	180 A	250 A
THERMAL INSULATION CLASS OF WIRE	F (+155°C)	F (+155°C)
THERMAL RESISTANCE	43°C/W	43°C/W

CONDUCTED DISTURBANCE IMMUNITY	BURST (acc. to EN 61000 - 4 - 4) level 4 (4 kV) SURGE (acc. to EN 61000 - 4 - 5) level 4 (4 kV)
--------------------------------	--

AC VERSION DATA

R values relate to +20°C. Tolerance of R and I values: ± 10%.

Rated voltage U _N	Operating range		Resistance R	Nominal coil absorption U _N 50 Hz I
	U _{min}	U _{max}		
V	V	V	Ω	mA
6	4.8	6.6	4.6	367
12	9.6	13.2	19	183
24	19.2	26.4	80	91.7
48	38.4	52.8	320	45.8
60	48	66	500	36.7
110	88	121	1,800	20
120	96	132	1,940	18.6
230	184	253	7,250	9.6
240	192	264	8,500	9.2

DC VERSION DATA

R values relate to +20°C. Tolerance of R and I values: ± 10%.

Rated voltage U _N	Operating range		Resistance R	Nominal coil absorption I
	U _{min}	U _{max}		
V	V	V	Ω	mA
6	4.8	6.6	28	214
12	9.6	13.2	110	109
24	19.2	26.4	445	53.9
48	38.4	52.8	1,770	27.1
60	48	66	2,760	21.7
110	88	121	9,420	11.7

CURRENT SENSING AC

R values relate to +20°C. Tolerance of R and I values: ± 10%.

Coil code	I _{min} (A)	I _N (A)	I _{max} (A)	R (Ω)
4501	4.25	5.0	6.0	0.01
4451	3.8	4.5	5.4	0.02
4401	3.4	4.0	4.8	0.02
4361	3.0	3.6	4.3	0.02
4321	2.7	3.2	3.8	0.03
4281	2.4	2.8	3.4	0.04
4251	2.1	2.5	3.0	0.05
4231	1.9	2.3	2.8	0.06
4201	1.7	2.0	2.4	0.08
4181	1.5	1.8	2.2	0.10
4161	1.4	1.6	1.9	0.12
4141	1.2	1.4	1.7	0.16
4121	1.0	1.2	1.4	0.22
4101	0.85	1.0	1.2	0.32
4091	0.8	0.9	1.1	0.40
4081	0.7	0.8	1.0	0.50
4071	0.6	0.7	0.9	0.65
4061	0.5	0.6	0.7	0.89
4051	0.42	0.5	0.6	1.28
4041	0.34	0.4	0.5	2.00
4031	0.25	0.3	0.4	3.57
4021	0.17	0.2	0.25	8.0
4011	0.085	0.1	0.15	32.1

CURRENT SENSING DC

R values relate to +20°C. Tolerance of R and I values: ± 10%.

Coil code	I _{min} (A)	I _N (A)	I _{max} (A)	R (Ω)
4502	4.25	5.0	6.0	0.020
4452	3.8	4.5	5.4	0.030
4402	3.4	4.0	4.8	0.038
4362	3.0	3.6	4.3	0.047
4322	2.7	3.2	3.8	0.059
4282	2.4	2.8	3.4	0.077
4252	2.1	2.5	3.0	0.10
4232	1.9	2.3	2.8	0.13
4202	1.7	2.0	2.4	0.15
4182	1.5	1.8	2.2	0.19
4162	1.4	1.6	1.9	0.24
4142	1.2	1.4	1.7	0.31
4122	1.0	1.2	1.4	0.42
4102	0.85	1.0	1.2	0.61
4092	0.8	0.9	1.1	0.75
4082	0.7	0.8	1.0	0.95
4072	0.6	0.7	0.9	1.24
4062	0.5	0.6	0.7	1.70
4052	0.42	0.5	0.6	2.40
4042	0.34	0.4	0.5	3.80
4032	0.25	0.3	0.4	6.70
4022	0.17	0.2	0.25	15.2
4012	0.085	0.1	0.15	61

COIL SPECIFICATIONS

R 60

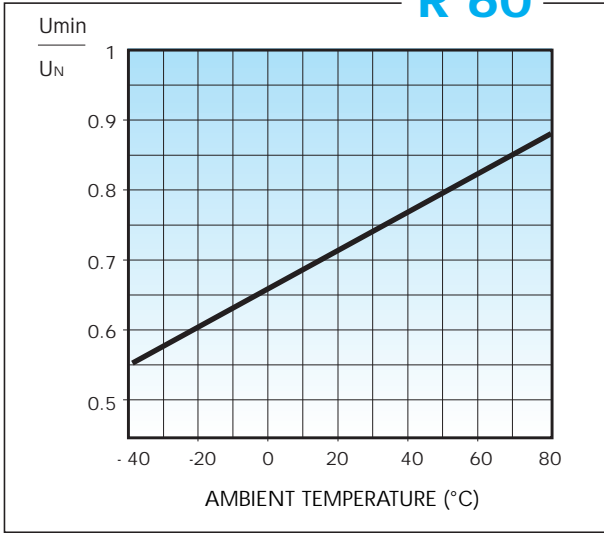

DC coil min pick-up voltage vs ambient temperature.
 U_{min} = pick-up voltage
 U_N = rated voltage

S 60/1

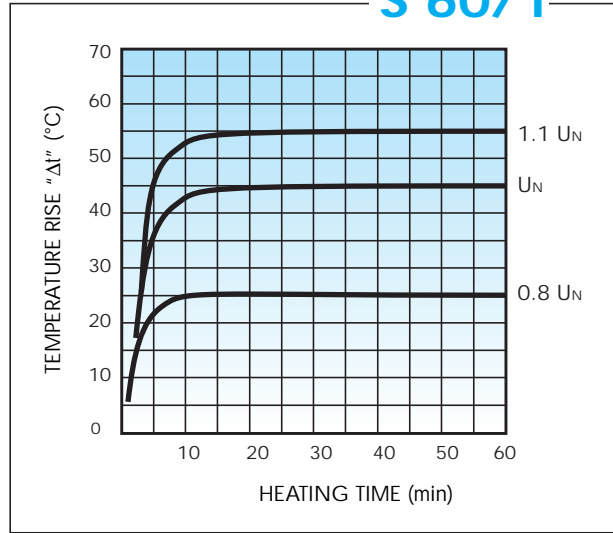

Temperature rise "Δt" vs applied voltage. DC coils.

S 60/2

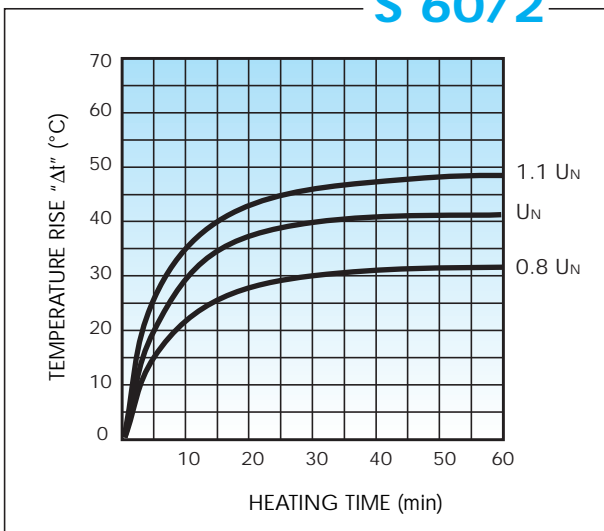

Temperature rise "Δt" vs applied voltage. AC 50 Hz coils.

S 60/3

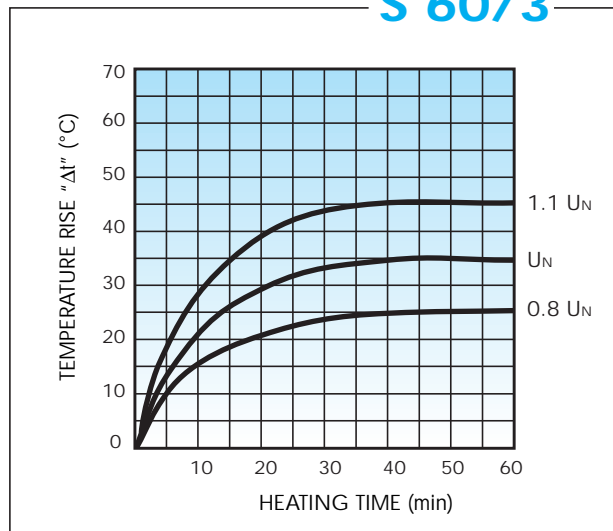

Temperature rise "Δt" vs applied voltage. AC 60 Hz coils.

ORDERING INFORMATION

Example: a 60 series 11-pin 3 CO (3PDT) plug-in relay with 12 V DC coil test button and mechanical indicator.

6 0	1	3	9	0 1 2	0	0	4	0
Series	No. of poles 2 = 2 CO (DPDT) 3 = 3 CO (3PDT)	Coil version 3 = DC diode in parallel to coil (positive to pin 2) 4 = Current sensing 8 = AC (50/60 Hz) 9 = DC	Coil rated voltage 006 = 6 V 012 = 12 V 024 = 24 V 048 = 48 V 060 = 60 V 110 = 110 V 125 = 125 V 230 = 230 V AC only	Contact material and contact circuit 00 = Standard 02 = AgNi bifurcated contacts 60.12/13 - 6 A only 20 = AgCdO 50 = AgNi + 5µm Au	Light and mechanical indicators 00 = Standard 10 = Test button* 20 = Mechanical indicator* 30 = LED + mechanical indicator (AC only)* 40 = Test button + mechanical indicator* 50 = Test button + LED (for AC)* 54 = Test button + LED (for AC)* + mechanical indicator* 60 = LED + diode, (positive to pin 2, DC only)* 70 = Test button + LED + diode (positive to pin 2)* 74 = Test button + LED + diode (positive to pin 2) + mechanical indicator*			Type 1 = 8/11 pin plug-in 6 = Faston 187 (4.8x0.8 mm)
* Available for 60.12 and 60.13 only								

OPTIONS



REAR DIN RAIL MOUNT (0008)



TEST BUTTON + MECHANICAL INDICATOR (0040)



LED (AC - 0300)

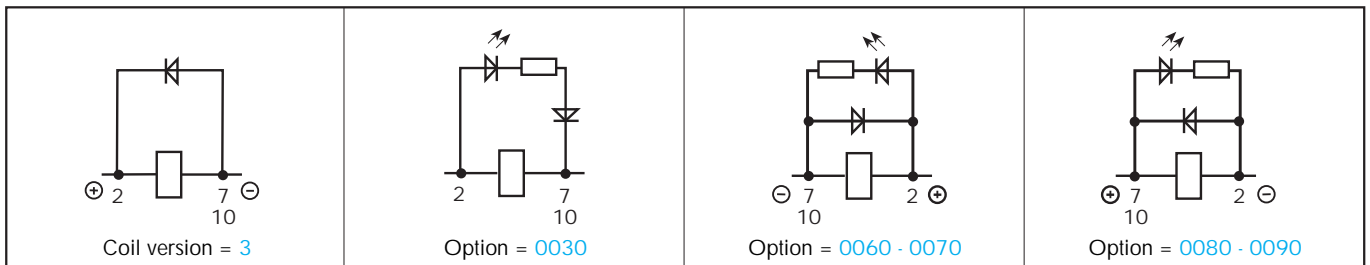



A range of sockets and accessories for the 60 series industrial relays and 28 series step relays
Features include:

- Solder, screw terminal, PCB, panel or DIN rail 46277 mount versions available
- Can be used with supply status indication, coil protection and timer modules (see 99 and 86.60)
- IP 20 finger protection
- Flammability in accordance with UL 94
- Approvals (according to type): BBJ, CSA, DEMKO, FIMKO, CS - IMQ, SEV, UL, cULus, VDE



90.12



90.14



FLANGE MOUNT SOLDER SOCKETS (flange mount with M3 screws)

TYPE 90.12 8 pins - for type 60.12

TYPE 90.13 11 pins - for type 60.13

CHARACTERISTICS

- LOAD: 10 A 250 V
- ISOLATION RESISTANCE: $\geq 10^3$ M Ω
- DIELECTRIC STRENGTH: ≥ 2 kV AC
- MATERIAL: phenolic resin (V0)
- CONNECTIONS: Cu Zn 33 nickel plated

P.C.B. SOCKETS

TYPE 90.14 8 pins - for type 60.12

TYPE 90.15 11 pins - for type 60.13

Options:

TYPE 90.14.1 - 17.5 mm diameter holes

TYPE 90.15.1 - 19 mm diameter holes

CHARACTERISTICS

- LOAD: 10 A 250 V
- ISOLATION RESISTANCE: $\geq 10^3$ M Ω
- DIELECTRIC STRENGTH: ≥ 2 kV AC
- MATERIAL: self-extinguishing PPEm (V1)
- CONNECTIONS: Cu Zn 33 tin plated

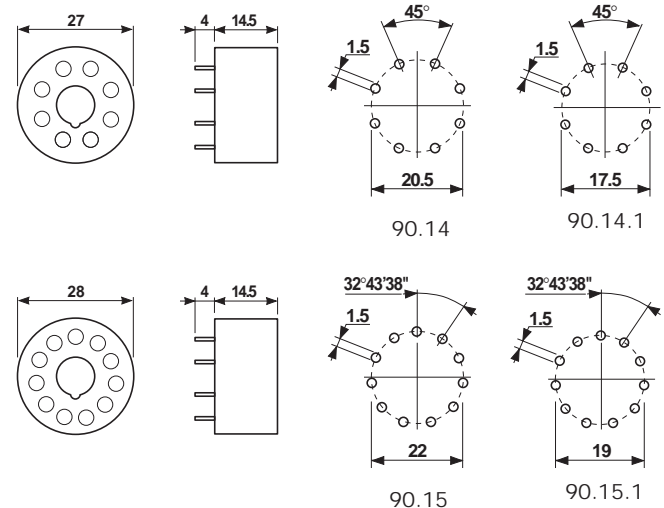
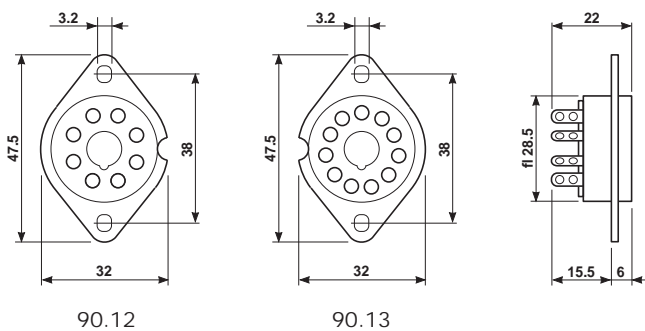



90.21



90.23



CLAMP TERMINAL SOCKETS (panel or DIN rail 46277 mount)

TYPE 90.20 8 pins - for type 60.12

TYPE 90.21 11 pins - for type 60.13

Accessories: **TYPE 090.33** retaining clip

TYPE 99.01 module facilities

CHARACTERISTICS

- LOAD: 10 A 250 V
- ISOLATION RESISTANCE: $\geq 10^3$ M Ω
- DIELECTRIC STRENGTH: ≥ 2 kV AC
- MATERIAL: self-extinguishing PPEm (V1)
- CONNECTIONS: Cu Zn 33 nickel plated
- PROTECTION CATEGORY: IP 20
- Non removable pozidrive slotted terminal screws.
- Identification label.

CLAMP TERMINAL SOCKETS (panel or DIN rail 46277 mount)

TYPE 90.22 8 pins - for type 60.12

TYPE 90.23 11 pins - for type 60.13

Accessories: **TYPE 090.33** retaining clip

CHARACTERISTICS

- LOAD: 10 A 250 V
- ISOLATION RESISTANCE: $\geq 10^3$ M Ω
- DIELECTRIC STRENGTH: ≥ 2 kV AC
- MATERIAL: self-extinguishing PPEm (V1)
- CONNECTIONS: Cu Zn 33 nickel plated
- PROTECTION CATEGORY: IP 20
- Non removable pozidrive slotted terminal screws.

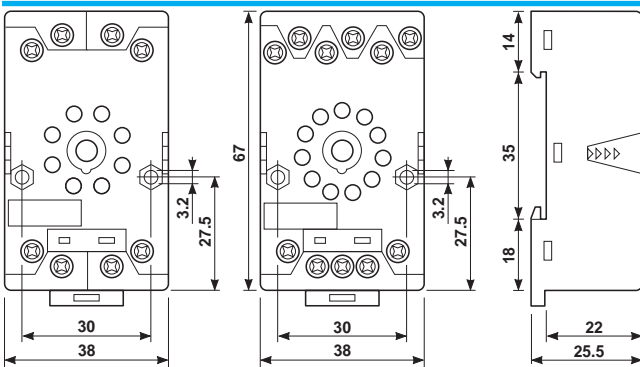

90.20

90.21

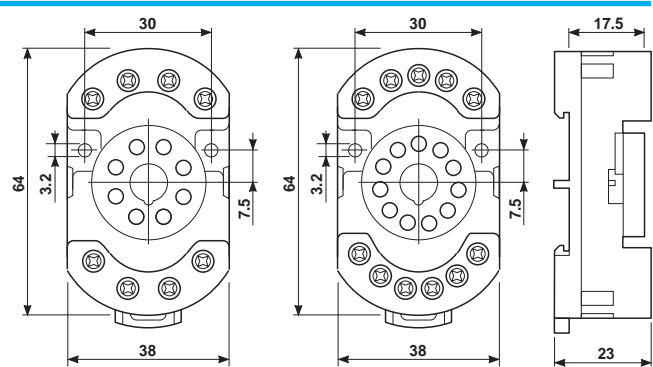

90.22

90.23

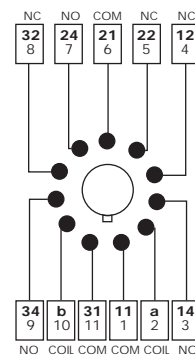
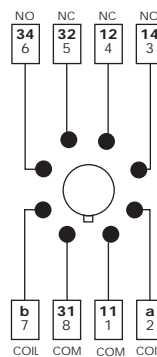
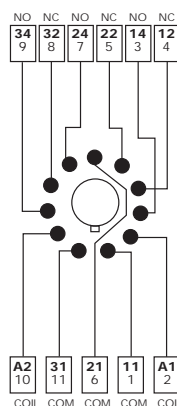
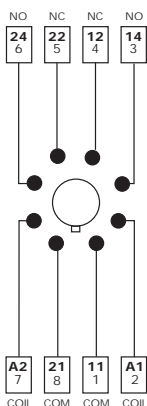



90.26



90.73



SCREW TERMINAL SOCKETS (panel or DIN rail 46277 mount)

TYPE 90.26 8 pins - for type 60.12

TYPE 90.27 11 pins - for type 60.13

Accessories: **TYPE 090.33** retaining clip

CHARACTERISTICS

- LOAD: 10 A 250 V
- ISOLATION RESISTANCE: $\geq 10^9$ M Ω
- DIELECTRIC STRENGTH: ≥ 2 kV AC
- MATERIAL: self-extinguishing PPEm (V1)
- CONNECTIONS: Cu Zn 33 nickel plated
- PROTECTION CATEGORY: IP 20
- Non removable pozidrive slotted terminal screws.

CLAMP TERMINAL SOCKETS (panel or DIN rail 46277 mount)

TYPE 90.72 8 pins - for type 60.12

TYPE 90.73 11 pins - for type 60.13

Accessories: **TYPE 090.33** retaining clip

TYPE 99.73 module facilities

TYPE 86.60 multifunction timer module

CHARACTERISTICS

- LOAD: 10 A 250 V
- ISOLATION RESISTANCE: $\geq 10^9$ M Ω
- DIELECTRIC STRENGTH: ≥ 2 kV AC
- MATERIAL: PA 66
- CONNECTIONS: Cu Zn 33 nickel plated
- PROTECTION CATEGORY: IP 20
- Non removable pozidrive slotted terminal screws
- Identification label
- Double ground terminal (A2)

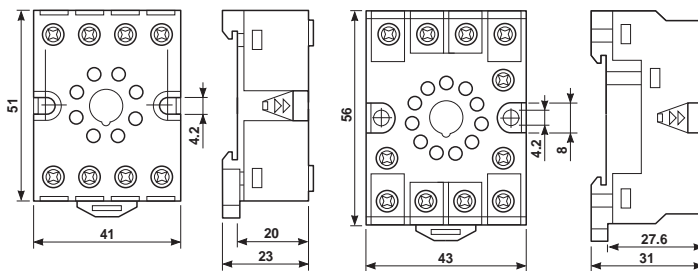

90.26

90.27

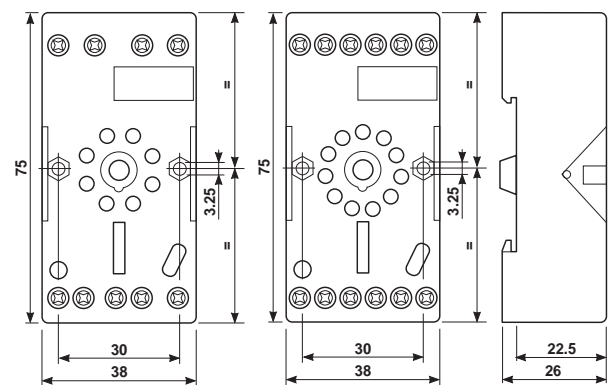

90.72

90.73

