

i7110
300 Mbps LED Drivers
Data Sheet

© Copyright 2005 iCreate Technologies Corporation

Information contained in this publication is intended through suggestion only and may be superseded by updates. No liability is assumed by iCreate Technologies Corporation with respect to the use of such information or otherwise and no representation or warranty is given. Use of iCreate's products as critical components in life support systems is not authorized.

No part of this document may be reproduced or transmitted in any form or by any means for any purpose without the permission of iCreate. No licenses are conveyed, implicitly or otherwise, under any intellectual property rights. The iCreate logo and name are registered trademarks of iCreate Technologies Corporation. All rights reserved. All other trademarks mentioned herein are the property of their respective companies.

Data sheet marking

iCreate uses various markings in the data sheet to designate each document phase as it relates to the product development stage.

Marking	Description
Objective Specification	The objective specification contains data for new product development.
Advance Information	The information is on products in the design phase. Your designs should not be finalized with this information.
Preliminary	This is preliminary information on new products but not yet fully characterized. The specifications in these data sheets are subject to change in any manner without notice.
No Marking	Information contained in the data sheet is on products in full production.

For more information please contact:

iCreate Technologies Corporation

No. 6, Technology Rd. V, Science-Based Industrial Park,
Hsinchu, Taiwan 300

Phone +886-3-579-0000

Fax +886-3-579-0077

e-mail support@icreate.com.tw

Revision : 3.00

Date : 05/2005

+3.3V to +5.0V, 300Mbps LED Driver

1 Introduction

1.1 General Description

The i7110 is a high-speed LED driver designed for low-cost optical fiber based transmission systems. Data rates up to 300Mbps can be achieved depending on the LED used.

The differential PECL inputs can be shaped by applying resistors between pulse width adjustment pins and ground. This adjustment is continuous over a ± 500 ps range to compensate the LED unbalanced 'turn on' and 'turn off' time. A peaking and clamp circuit is implemented in i7110 to enhance speed performance and connecting external RC network performs this function.

The i7110 can switch a wide range of current 5mA to 120mA into typical LEDs. To minimize the effects of temperature on LED output power, the device's modulation current can be set via two external resistors to increase with a temperature coefficient from 800ppm/°C to 10000ppm/°C.

Complementary current outputs help to maintain a constant supply current, reducing EMI and supply noise generated by the transmitter module, and the current is disabled if pin Disa is Pulled high. The i7110 is packaged in QSOP16 and TSSOP20.

1.2 Applications

- ◇ FDDI
- ◇ SDH STM-1
- ◇ SONET OC-3
- ◇ Fast Ethernet
- ◇ Fiber Channel

1.3 Features

- ◇ Data rates up to 300 Mbps, depending on LED.
- ◇ +5 V to +3.3 V operation.
- ◇ Programmable output current from 5mA to 120mA.
- ◇ Peaking circuit giving rise and fall time < 700ps.
- ◇ Clamping circuit enhances turn off time.
- ◇ Resistor programmable compensation for temperature dependence of LED output.
- ◇ PECL input with optional pulse width adjustment.
- ◇ Support most LED types.
- ◇ Support output current disable ability.
- ◇ Single Chip solution, available in TSSOP20 or QSOP16.

1.4 Ordering Information

Part no.	Package
i7110-ES	16-pin QSOP
i7110-EG	16-pin QSOP
i7110-EP	20-pin TSSOP

* i7110-EG is provided in green package

i7110

2 Pin Configuration and Definition

2.1 Pin Configuration

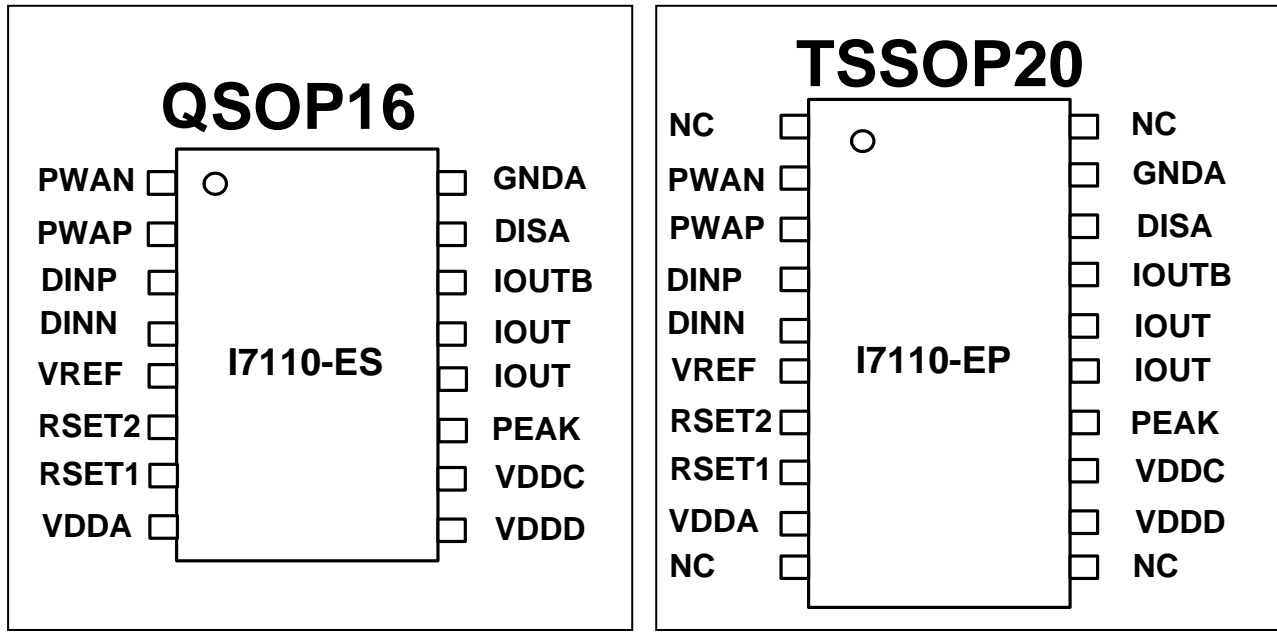

Figure 1. i7110 pin configuration

2.2 Pin Definition

Pin Name	TSSOP20 Pin No.	QSOP16 Pin No.	Description
NC	1	-	Not connected
PWAN	2	1	Inverse pulse width adjustment input
PWAP	3	2	Differential pulse width adjustment input. Allows continuous adjustment of input data pulse width
DINP	4	3	Non inverting data input pin
DINN	5	4	Inverting data input pin
VREF	6	5	Input reference voltage. Connect VREF to DINN for single ended input
RSET2	7	6	Temperature compensation adjustment pin. Allows temperature dependence of LED light output to be reduced or removed
RSET1	8	7	Set nominal LED drive current
VDDA	9	8	Power pin, connect to most positive supply
NC	10	-	Not connected
NC	11	-	Not connected
VDDD	12	9	Power pin, connect to most positive supply
VDDC	13	10	LED shorting pin, connect to most positive supply. Speeds LED switch off
PEAK	14	11	Connection for pre-emphasis or peaking circuit
IOUT	15,16	12,13	Driver output
IOUTB	17	14	Connect a resistor between this pin and VCC
DISA	18	15	Control pin for disable current-out
GNDA	19	16	Ground pin

3 Block Diagram

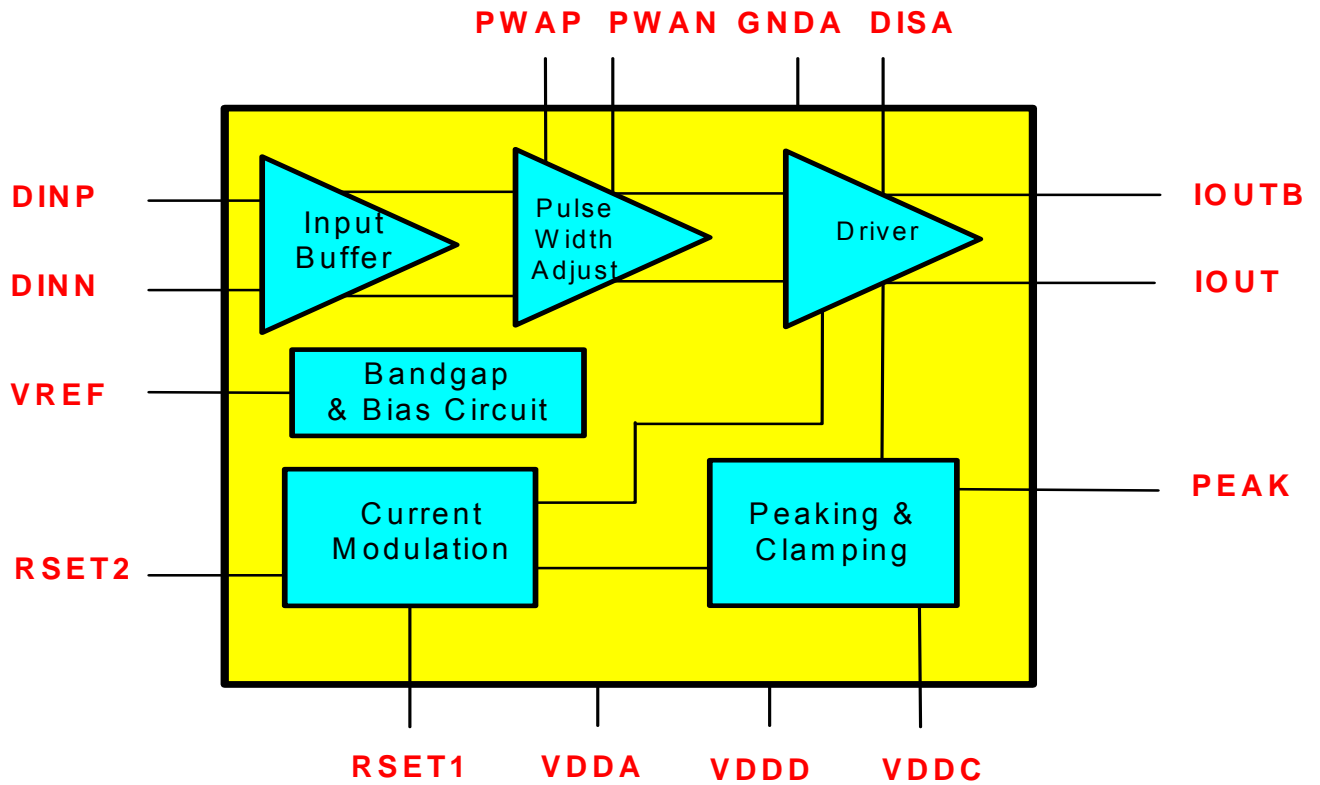

Figure 2. i7110 block diagram

4 Electrical Specifications

4.1 Recommended Operating Conditions

Parameter	Symbol	Rating	Unit
Power Supply	VCC	3.0 to 5.5	V
Operating Ambient	TA	-40 to 85	°C

4.2 DC Electrical Characteristics

(VCC = 3.0 V to 5.5 V, TA = -40 °C to 85 °C, unless otherwise noted. Temperature coefficients are referenced to TA = +25°C. Typical values are at TA = +25°C, VCC = 3.3V)

Symbol	Parameter	Min	Typ	Max	Units
V _{IN_H}	Input high voltage level	VCC-1.0	-	VCC-0.8	V
V _{IN_L}	Input low voltage level	VCC-2.0	-	VCC-1.8	V
I _{OUT_ON}	LED drive current	5	-	120	mA
I _{OUT_OFF}	LED off current	-	-	50	uA
VREF	Voltage reference	VCC-1.6	VCC-1.4	VCC-1.03	V
VLEDH	LED headroom voltage	-	-	2	V

4.3 AC Electrical Characteristics

(VCC = 3.0 V to 5.5 V, TA = -40°C to 85 °C, unless otherwise noted. Temperature coefficients are referenced to TA = +25°C. Typical values are at TA = +25°C, VCC = 3.3V)

Symbol	Parameter	Min	Typ	Max	Units
LED t _R	LED drive rise time	-	0.7	1	ns
LED t _F	LED drive fall time	-	0.7	1	ns
PEAK t _R	Peaking current rise time	-	-	1	ns
PEAK t _F	Peaking current fall time	-	-	1	ns
I _{DD}	Supply current	-	I _{LED} +10	I _{LED} +20	mA

4.4 Typical Operating Curve

(I7110 characteristic curve tested at VCC=3.3V , 5V. IOUT, IOU_{TB} connect 10Ω resistor to VCC, VREF is floating , DINP connects to VCC, DINN connects to GND)

Modulation Current VS RSET1 VCC=3.3V

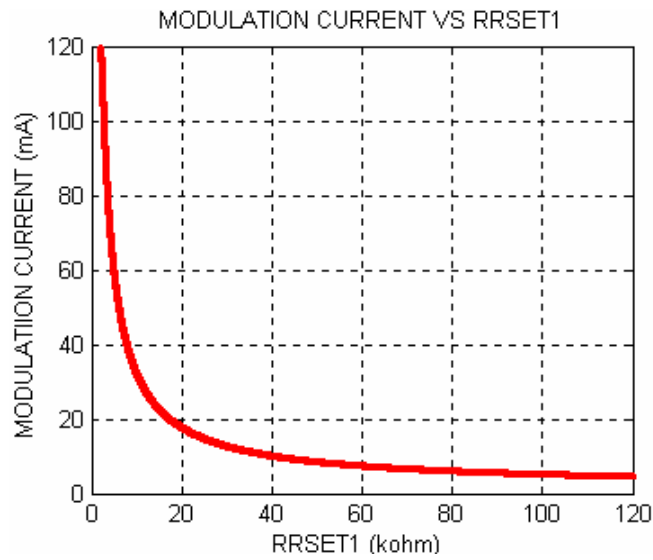

Figure 3

Modulation Current VS RSET2 VCC=3.3V

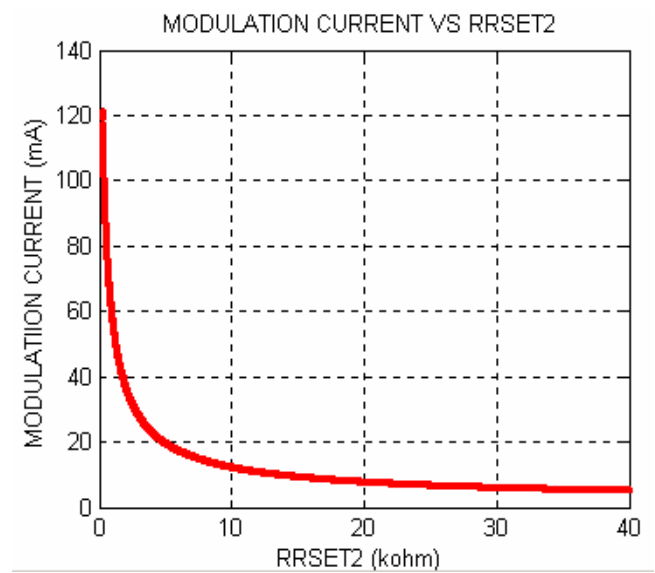

Figure 5

Modulation Current VS RSET1 VCC=5V

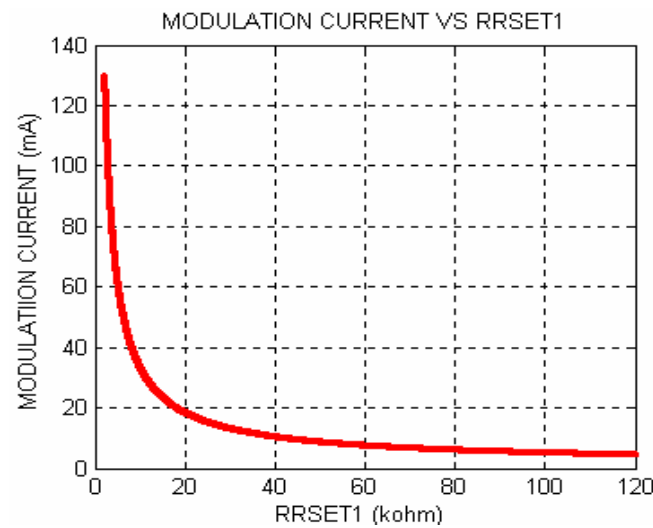

Figure 4

Modulation Current VS RSET2 VCC=5V

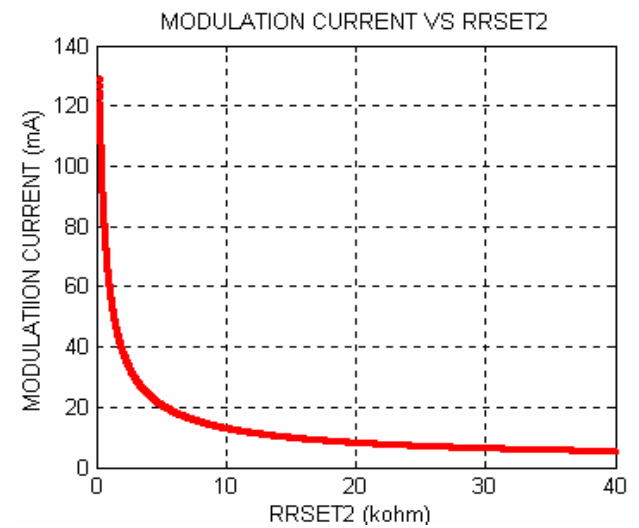

Figure 6

4.5 Temperature Compensation Contour Plot

(I7110 characteristic curve , relationship between modulation current with RSET1 & RSET2. IOUT, IOUTB connect 10Ω resistor to VCC, VREF is floating , DINP connects to VCC, DINN connects to GND)

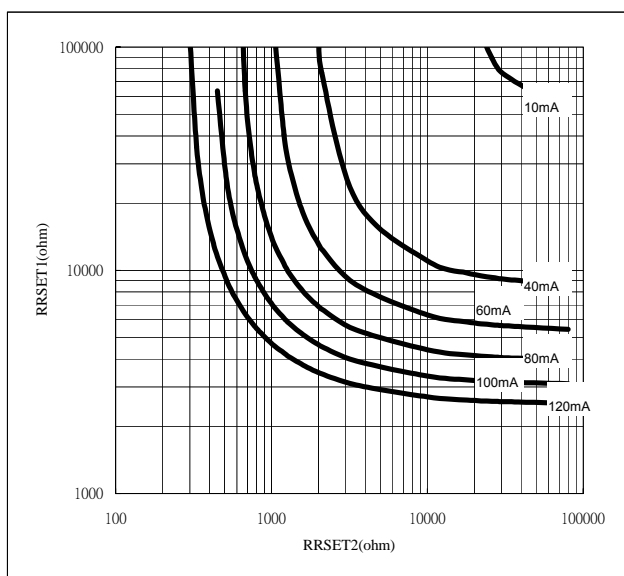

Figure7. Tj = 50 degree

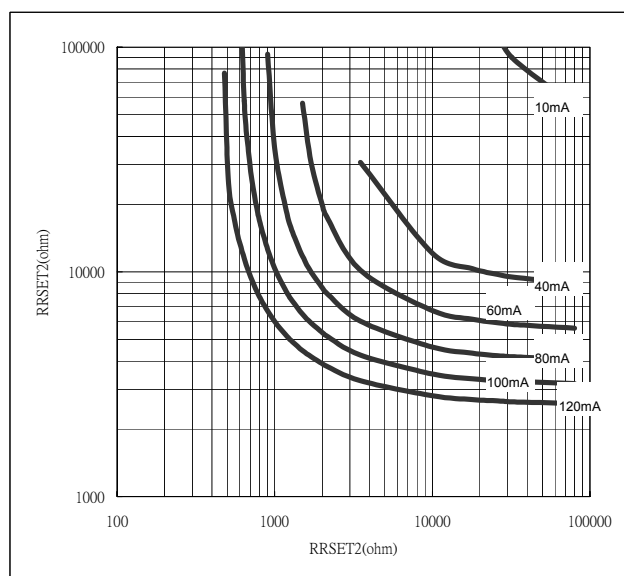

Figure8. Tj = 75degree

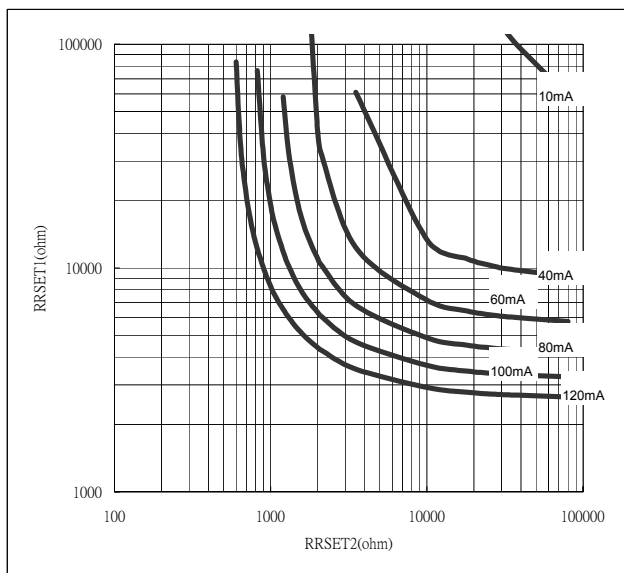

Figure 9. Tj = 100degree

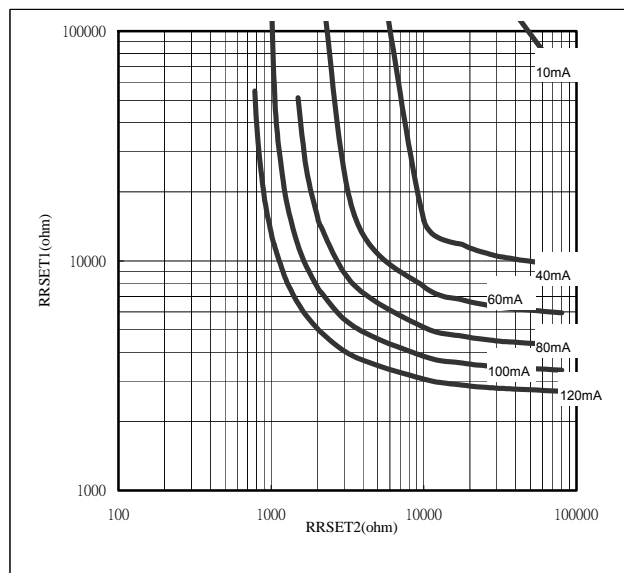

Figure 10 Tj = 125 degree

4.6 Detail Description

The i7110 provides a flexible current drive for the modulation of the light-emitting diodes(LEDs). The circuit is designed to use 3.3V ~ 5V power supply. The IC provides up to 120mA of modulation current.

Figure-11 shows a typical block diagram of i7110, which comprises a bandgap, current modulation block, peaking and clamping block, an input buffer, pulse width adjustment function block and the output driver.

Reference-Voltage Generate

The reference-voltage generator circuit provides single-ended input reference voltage VREF.

The VREF is used to simplify the PECL-compatible input. For single-ended operation, connect the input signal to DINP, and connect DINN directly to VREF. The VREF circuit is not designed to drive other external circuitry.

LED Drive and Temperature Compensation

The two resistors RRSET1 and RRSET2 set the LED drive current and temperature compensation. The simplified application diagram (Figure-11) shows RRSET1 connects between RSET1 and GND, and RRSET2 connects between RSET1 and RSET2.

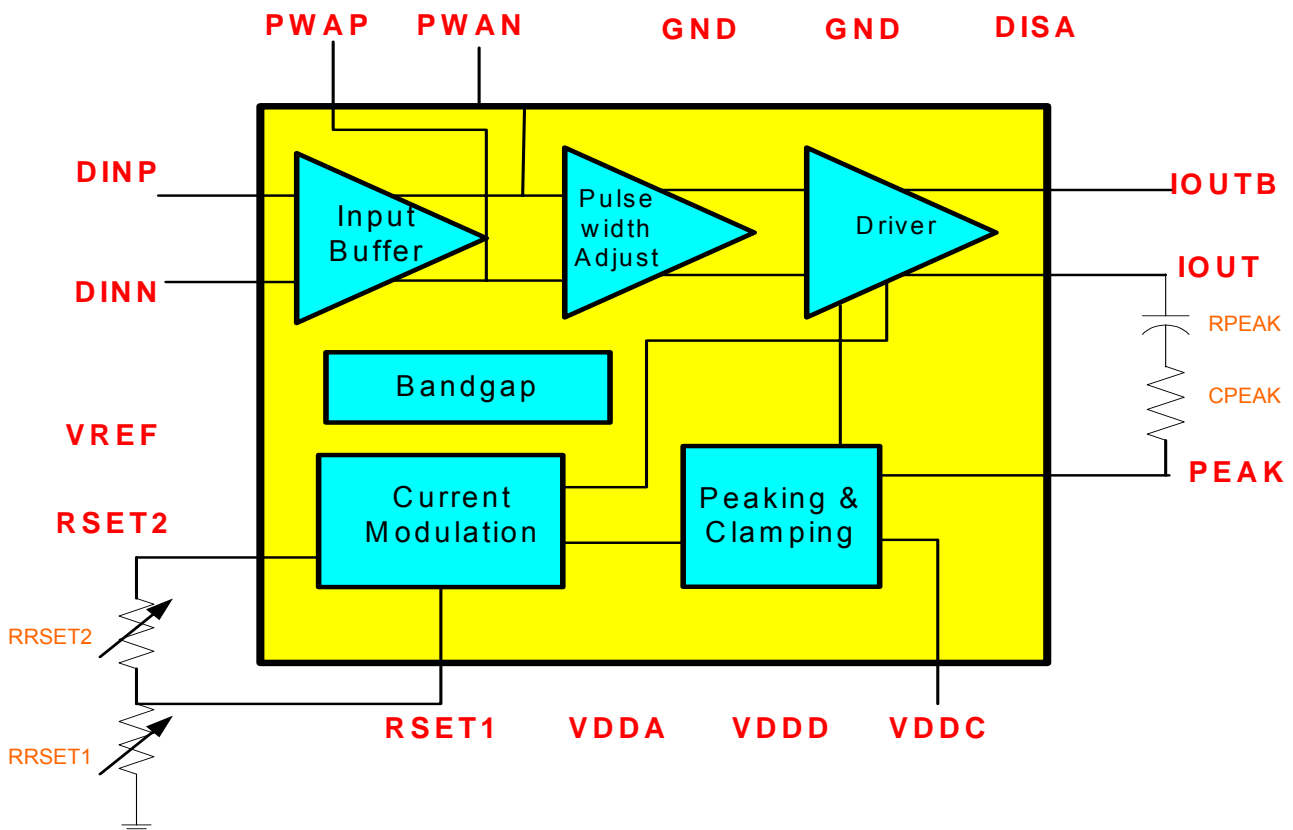

Figure-11

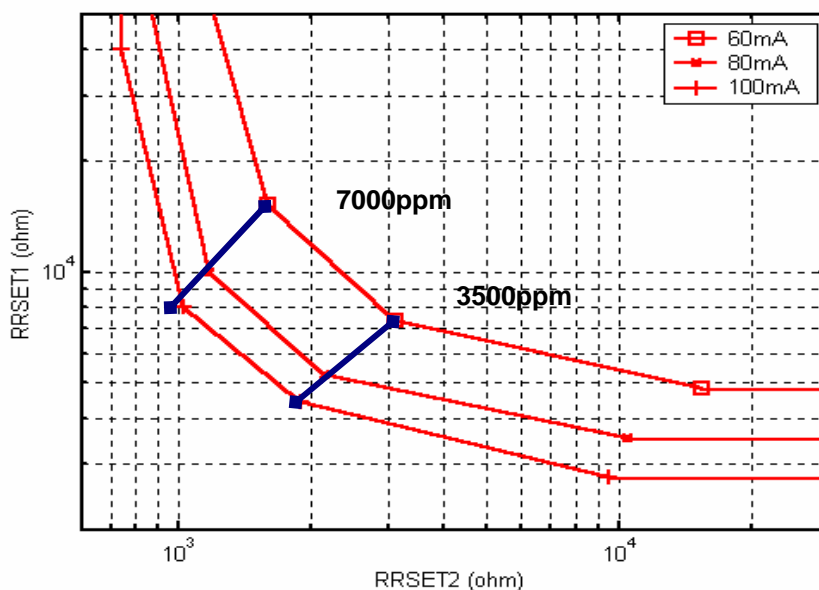

Figure-12

The current flows out of the RSET1 pin determine the LED drive current.

The temperature independent LED driving current is set mainly by RRSET1, while the temperature dependent current is set mainly by RRSET2. However RRSET1 and RRSET2 are not independent.

The RSET2 pin connects to an internal diode in the IC, which exhibits standard diode behavior with temperature. As temperature rises, the voltage on RSET2 drops, the current flows through diode increases and the LED drive current increases.

Given the various interdependencies of the drive current, RRSET1 and RRSET2, the relationship with temperature compensation is plotted in Figure-12

Peaking Function

To improve LED 'turn on' time an optional function 'peaking' is included in 'i7110'. If this is not required, then the pin PEAK should be left

floating. Two external components are required to implement peaking. As shown in figure-11. When the LED is turned on, the voltage on peak is pulled low very rapidly. This voltage transient is coupled through RPEAK and CPEAK and exerts a transient current on the LED.

When the LED is turned off, the voltage on PEAK is pulled high very rapidly. This Voltage transient is coupled through RPEAK and CPEAK and exerts a transient current in the opposite direction on the LED.

The transient current amplitude and RC decay are calculated approximately by:

$$\text{Peak current (Amps): } VCC / (RPEAK+3.8)$$

$$\text{Decay (seconds): } CPEAK*(RPEAK+3.8)$$

Typical value for CPEAK and RPEAK at 3.3V operation are:

$$CPEAK = 20 \text{ pf}$$

$$RPEAK = 10 \text{ ohm}$$

LED Clamping, Laser Driving

Since most LEDs exhibit a longer 'turn off' time than 'turn on' time, a clamping function is included on the i7110 in order to reduce the 'turn off' time. And the function is enabled by simply connecting pin VDDC to VCC.

The disadvantage of clamping is that the LED's internal capacitance must be fully charged again before the LED starts to emit light. This will delay the turn on time of LED especially when LED drive current is low. Use of peaking function will reduce the 'turn on' delay. The combination of peaking and clamping results in very fast 'turn on' and 'turn off' speed for the LED.

When driving lasers, it will often be helpful to disable this clamping. This can be achieved by leaving the VDDC connections floating.

LED Drive Pulse Width Adjustment (PWA)

The input signal pulse width can be adjusted before the output stage. The differential voltage on the PWA pins shapes the input pulse

Continuously over a -500ps to $+500\text{ps}$ range.

The maximum difference between PWAP and PWAN is $\pm 1\text{v}$. PWAP and PWAN will settle at a voltage equal to $(0.76 * \text{VCC})$ if left floating. It is recommended that adjustment be implemented by pull down resistors on PWAP and PWAN. However it is common for one or other pin to be tied to ground for maximum adjustment.

5 Typical Application Circuits

5.1 QSSOP16 Application Circuit

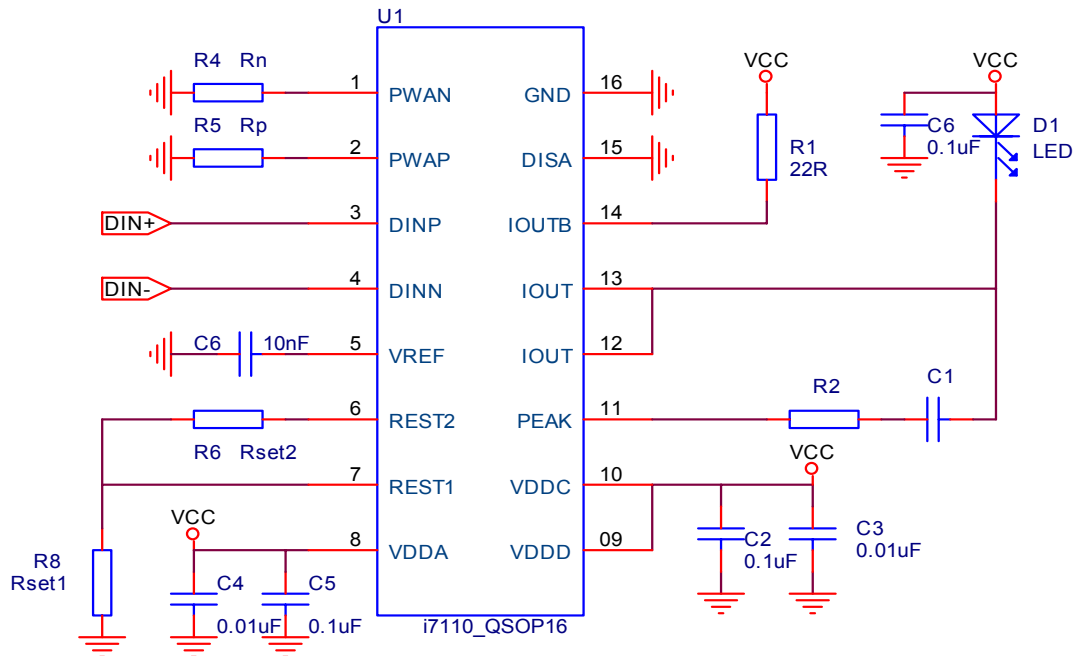

undershoot / overshoot can be optimized by C1 & R2.
 Typical C1=20pF ; R2=0 ohm @3V.
 Typical C1=10pF ; R2=100 ohm @5V.
 Rest2 : Temperature compensation adjustment.
 Rest1 : Set nominal LED drive current.
 Rn & Rp : Pulse width adjustment.

Figure 13.

5.2 TSSOP20 Application Circuit

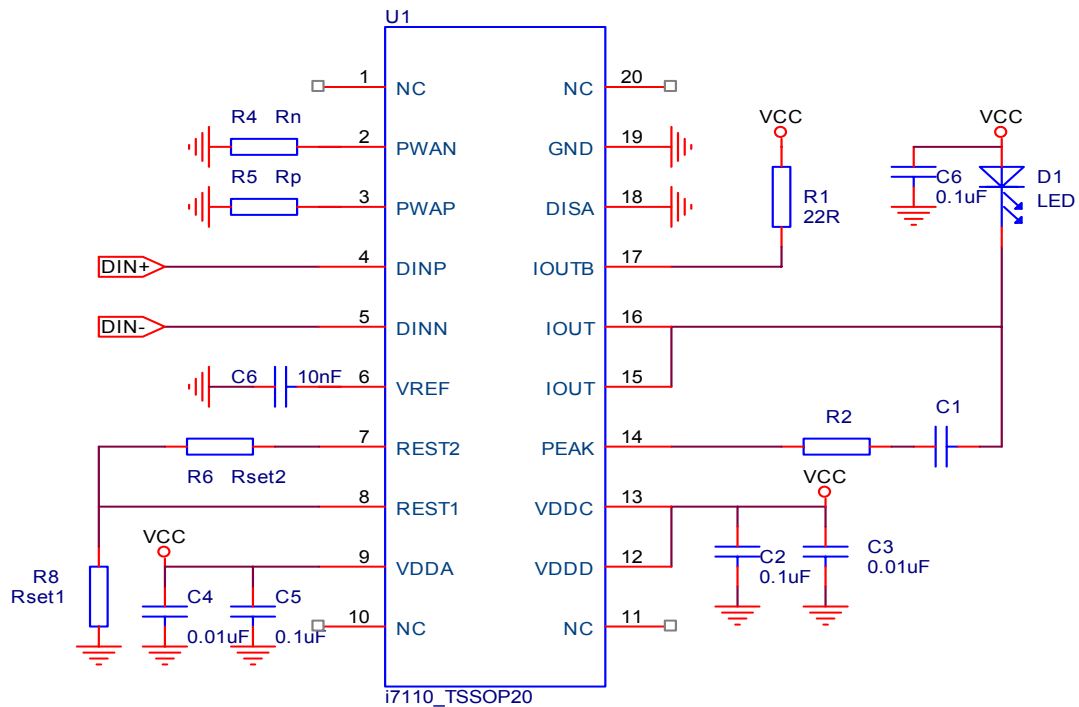

undershoot / overshoot can be optimized by C1 & R2.
 Typical C1=20pF ; R2=0 ohm @3V.
 Typical C1=10pF ; R2=100 ohm @5V.
 Rest2 : Temperature compensation adjustment.
 Rest1 : Set nominal LED drive current.
 Rn & Rp : Pulse width adjustment.

Figure 14

6 Package Outline

6.1 Package Outline - 16-pin QSOP

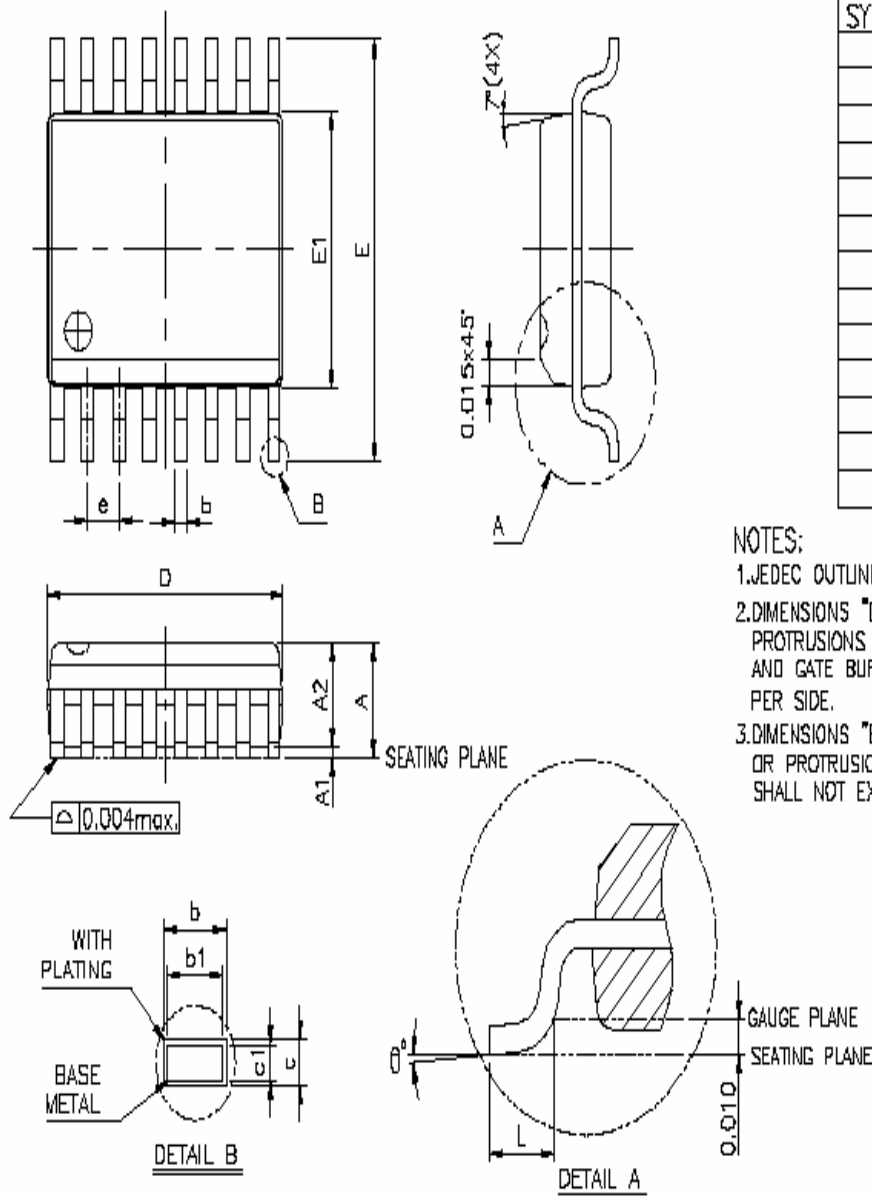

SYMBOLS	MIN.	MAX.
A	0.053	0.069
A1	0.004	0.010
A2	-	0.059
b	0.008	0.012
b1	0.008	0.011
c	0.007	0.010
c1	0.007	0.009
D	0.189	0.197
E1	0.150	0.157
E	0.228	0.244
L	0.016	0.050
e	0.025	BASIC
θ°	0	8

UNIT : INCH

NOTES:

1. JEDEC OUTLINE : MO-137 AB
2. DIMENSIONS "D" DOES NOT INCLUDE MOLD FLASH, PROTRUSIONS OR GATE BURRS. MOLD FLASH, PROTRUSIONS AND GATE BURRS SHALL NOT EXCEED .15mm (.006in) PER SIDE.
3. DIMENSIONS "E" DOES NOT INCLUDE INTER-LEAD FLASH, OR PROTRUSIONS. INTER-LEAD FLASH AND PROTRUSIONS SHALL NOT EXCEED .25mm (.010in) PER SIDE.

6.2 Package Outline – 20-pin TSSOP

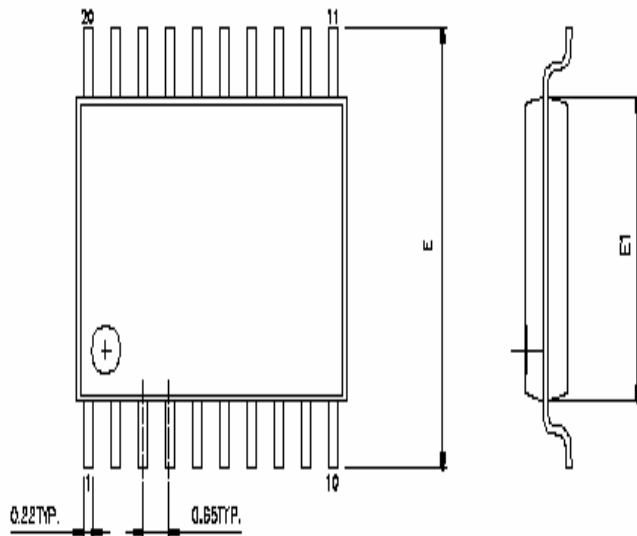

SYMBOLS	MIN.	NOM.	MAX.
A	-	-	1.20
A1	0.05	-	0.15
A2	0.98	1.01	1.06
D	6.40	6.50	6.60
E	6.40 BSC		
E1	4.30	4.40	4.50
L	0.45	0.60	0.75
Ø	0	-	8

UNIT : MM

NOTES:

1. JEDEC OUTLINE : MO-163 AC
2. DIMENSION 'D' DOES NOT INCLUDE MOLD FLASH, PROTRUSIONS OR GATE BURRS. MOLD FLASH, PROTRUSIONS OR GATE BURRS SHALL NOT EXCEED 0.15 MM PER SIDE.
3. DIMENSION 'E1' DOES NOT INCLUDE INTERLEAD FLASH OR PROTRUSION. INTERLEAD FLASH OR PROTRUSION SHALL NOT EXCEED 0.25 PER SIDE.
4. DIMENSION '0.22' DOES NOT INCLUDE DAMBAR PROTRUSION. ALLOWABLE DAMBAR PROTRUSION SHALL BE 0.08 MM TOTAL IN EXCESS OF THE '0.22' DIMENSION AT MAXIMUM MATERIAL CONDITION. DAMBAR CANNOT BE LOCATED ON THE LOWER RADIUS OF THE FOOT. MINIMUM SPAC BETWEEN PROTRUSION AND ADJACENT LEAD IS 0.07 MM.
5. DIMENSIONS 'D' AND 'E1' TO BE DETERMINED AT DATUM PLANE Ø.

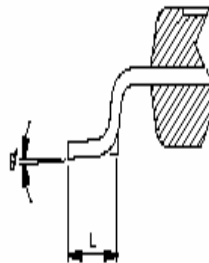
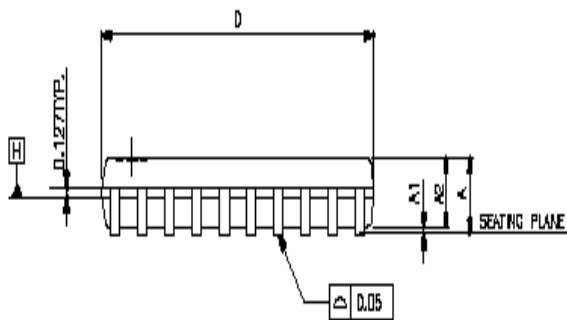

iCreate Technologies Corporation

No. 6, Technology Rd. V, Science-Based Industrial Park,
Hsinchu, Taiwan 30077, R.O.C.

Tel: +886-3-579-0000 Fax: +886-3-579-0077