

Piezoelectric Transformers

www.DataSheet4U.com

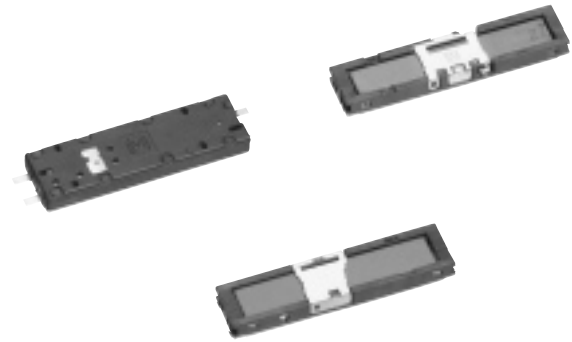

Designed for LCD back light inverter for portable electronic equipment such as Notebook PCs. Any applications where space saving, light weight, low power consumption and safety are essential.

■ Features

- Thin and high transfer efficiency of 93%
- Lower EMI radiations due to the unique piezoelectric inverter system

■ Recommended Applications

- Back light inverter for LCD
- High voltage power supply

■ Safety Precautions (See Page 234)

■ Explanation of Part Numbers

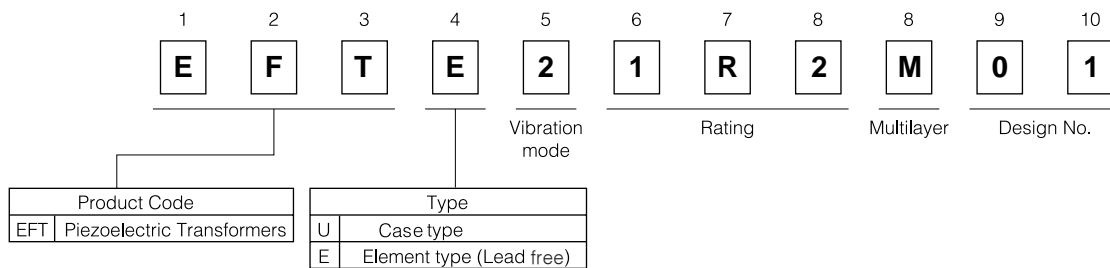

■ Rating and Characteristics (Typ.)

Characteristics	Part No.		
	EFTU21R203	EFTU44R0M03	EFTU14R0M□□
Type	Bulk	Multilayer	Multilayer
Vibration Mode	Rosen λ Drive	Center λ / 2 Drive	Rosen λ / 2 Drive
Input Power (W)	1.2	4	4
Transfer Efficiency (%)	88 min.	88 min.	88 min.
Transfer Ratio	6.3	33	33 to 60
Resonant Frequency (kHz)	147.5	55.6	56.5

* Load resistance (at 95 kΩ)
 * Please contact us for more information.

■ Dimensions in mm (not to scale)

EFTU21R203

www.DataSheet4U.com

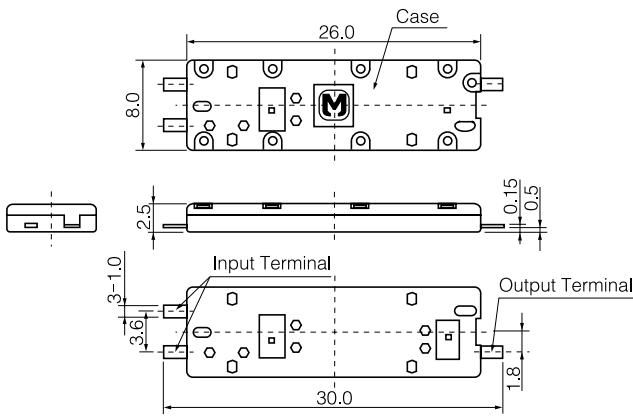

EFTU44R0M03

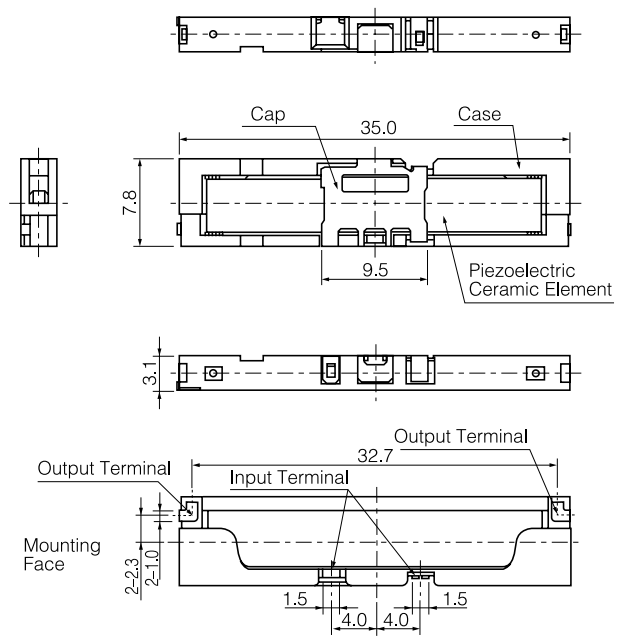

EFTU14R0M□□

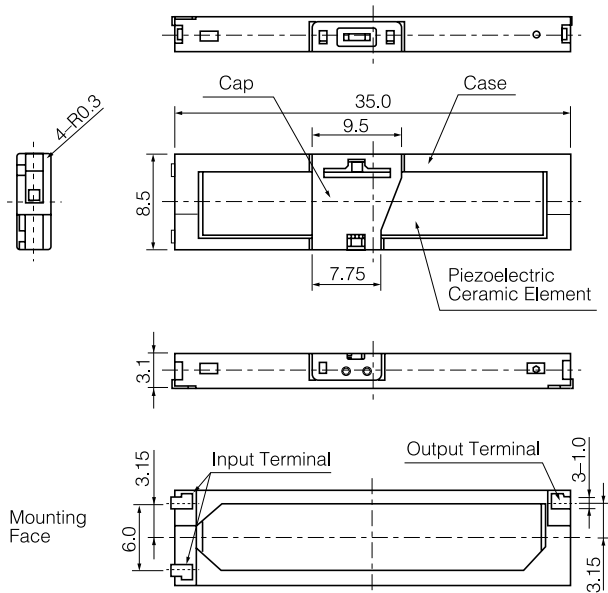

■ Application Example

LCD back light inverter circuit.

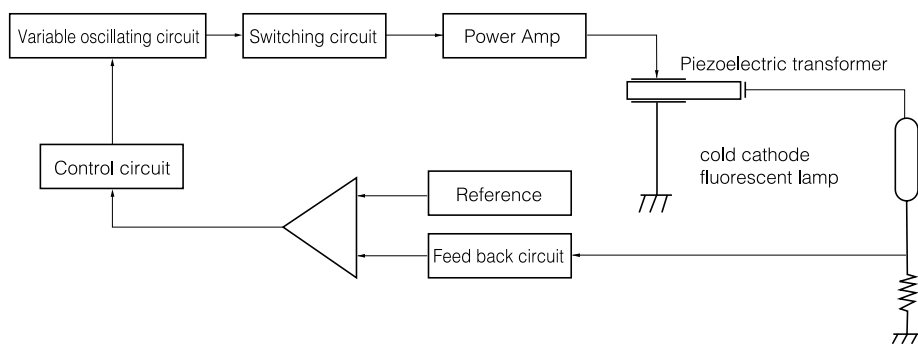

Design, Specifications are subject to change without notice. Ask factory for technical specifications before purchase and/or use. Whenever a doubt about safety arises from this product, please inform us immediately for technical consultation without fail.

Piezoelectric Transformers

www.DataSheet4U.com

Handling Precautions

Piezoelectric Transformers may fail in either short-circuit or open-circuit mode. When subjected to severe electrical/environmental conditions and/or mechanical stresses beyond the specified ratings, overheating and/or damage may result. Failure to follow the "SAFETY PRECAUTIONS" or "Application NOTES" may result in product malfunction. If you have questions regarding the "SAFETY PRECAUTIONS" or Application Notes, please contact our engineering section or factory.

⚠ Safety Precautions

- 1 When Piezoelectric Transformers are operated beyond their specified electrical and environmental ratings, they may overheat or burn out.

For safety, it is recommended that you establish a protective circuit for over heating. The assembled components and materials near the transformer should be of a flame-retardant type material (UL94V-0 or equivalent) and of a high heat resistance.
- 2 Piezoelectric transformers, should be covered with protective cases to prevent accidental contact and electric shock. "Warning - High Voltage" should be labeled on surface of the protective case.
- 3 Piezoelectric Transformers should be free from combustible materials or dust to reduce the likelihood of a flaming burnout or current discharge.

2 Precautions for Assembly

- 2.1 Excessive mechanical stresses such as vibration and shock, may cause breakage, cracking and/or damage to the ceramic element. Handle the transformers carefully during assembly. Do not use parts that have been dropped.

3 Environmental Conditions

- 3.1 The Piezoelectric Transformers shall not be operated under dew formation conditions.
- 3.2 Piezoelectric Transformers without protective coating should not be operated under corrosive atmospheres such as hydrogen chloride, sulfur dioxide and hydrogen sulfide etc. These corrosive substances will corrode the electrodes of the transformers and may cause malfunction.
- 3.3 The Piezoelectric Transformer, generating high voltage in their operations, shall be free from electrically conductive dust and combustible dusts.

■ Application Notes

- 1 Considerations for Circuit Designs
 - 1.1 Any DC voltage (or bias voltage) should not applied to the Piezoelectric Transformer. Application of DC voltage may deteriorate the Transformers electrical characteristics.
 - 1.2 Ratings and Characteristics of Piezoelectric Transformers are based on measurements at the specified fundamental frequency of the sinusoidal voltage curve. A driving voltage of higher frequency harmonics may cause over heating of the element and/or damage.
 - 1.3 The Output voltage of the Piezoelectric Transformer depends on the connected impedance load. Operating with a relatively higher loaded resistance, or with an open circuit may cause abnormal over heating or damage to the element. In any case, the output voltage of the transformer should be limited to the specified maximum output voltage.

4 Long Term Storage

- 4.1 The Piezoelectric Transformers should be stored in their factory sealed packaging.

Design, Specifications are subject to change without notice. Ask factory for technical specifications before purchase and/or use. Whenever a doubt about safety arises from this product, please inform us immediately for technical consultation without fail.