

---

## Features

- ATR0640-EK users guide
- Evaluation board based on Atmel's GPS Chipset
- Ashtech® Evaluate Software for performance monitoring and data-logging
- An active, magnetic-based, GPS antenna with a 3 meter cable
- Cigarette lighter adapter
- 110VAC – 12VDC power adapter
- Serial Cable

## Description

The ATR0640 GPS chipset is based on GPS technology licensed from Thales Navigation, a market leader in the GPS industry.

To ensure the ATR0640 chipset is right for your application, Atmel offers a low cost evaluation kit. The ATR0640-EK evaluation kit comes in a sturdy carrying case and provides all the tools necessary to evaluate the capabilities and performance of the ATR0640 chipset.

ATR0640-EK Evaluation Kit Contents



---

**Atmel Baldur™  
Evaluation Kit**

---

**ATR0640-EK**

**Preliminary**

5105A-GPS-06/05





The GPS evaluation board is housed in a ruggedized plastic enclosure that can easily be used for bench characterization or driving over the road. LEDs are visible to monitor the current system state. Data is transferred via an RS232 serial cable from the evaluation board to the serial port on your PC via NMEA formatted messages. Every system comes with firmware already loaded into the receiver, ready to plug and play. A 12V DC input is all that is required to power the system.

#### Evaluation Board with Cover Removed



To evaluate the performance of the system, software is provided to monitor all aspects of the system operation in real-time or by reviewing a data-logged file of a previous trip for later analysis. The graphic display shows information such as satellite tracking, strength of signal, position, velocity and time.

#### ATR0640-EK and Accessories



## Specifications

**Table 1.** Specifications

Characteristic	Details	Value
Position Accuracy	Autonomous (without corrections)	4.0m
	With WAAS/EGNOS/MSAS Corrections	2.0m
	With DGPS Corrections	1.0m
Acquisition Time	Typical Acquisition Time <sup>(1,2,3)</sup>	Hot Start < 10 sec Warm Start < 45 sec Cold Start < 150 sec
	Typical Reacquisition Time	< 1 sec
Dynamics	Sensitivity	-145 dBm
	Max. Velocity	425 m/s (951 mph)
	Altitude	-500m to +17,500m (-1600 to 57,400 ft)
	Data Output Rate	1 Hz
Communication	Standard NMEA-0183 V2.2 output messages	\$GGA, \$GSA, \$ZDA, \$RMC, \$GLL, \$GSV
Electrical Characteristics	Power (Reference Design)	35 mA, typ
	Voltage	2.7 – 3.3 VDC, I/O ring 1.8V ±5% core logic
	Back-up Power	< 12 µA @ 25 C
	GPS signal input, SIGI	400 mV p-p (min) 800 mV p-p (typ) 1.8V p-p (max) AC coupled
	Reference Clock Input	16.367667 MHz from RF section 400 mV p-p (min) 800 mV p-p (typ) 1.8V p-p (max) AC coupled

- Notes:
1. Cold – No Time/Position/Ephemeris
  2. Warm – Estimate of Time and/or Position, Collecting Ephemeris
  3. Hot – Up-to-Date Time/Position/Ephemeris

### ATR0640 Chipset Block Diagram

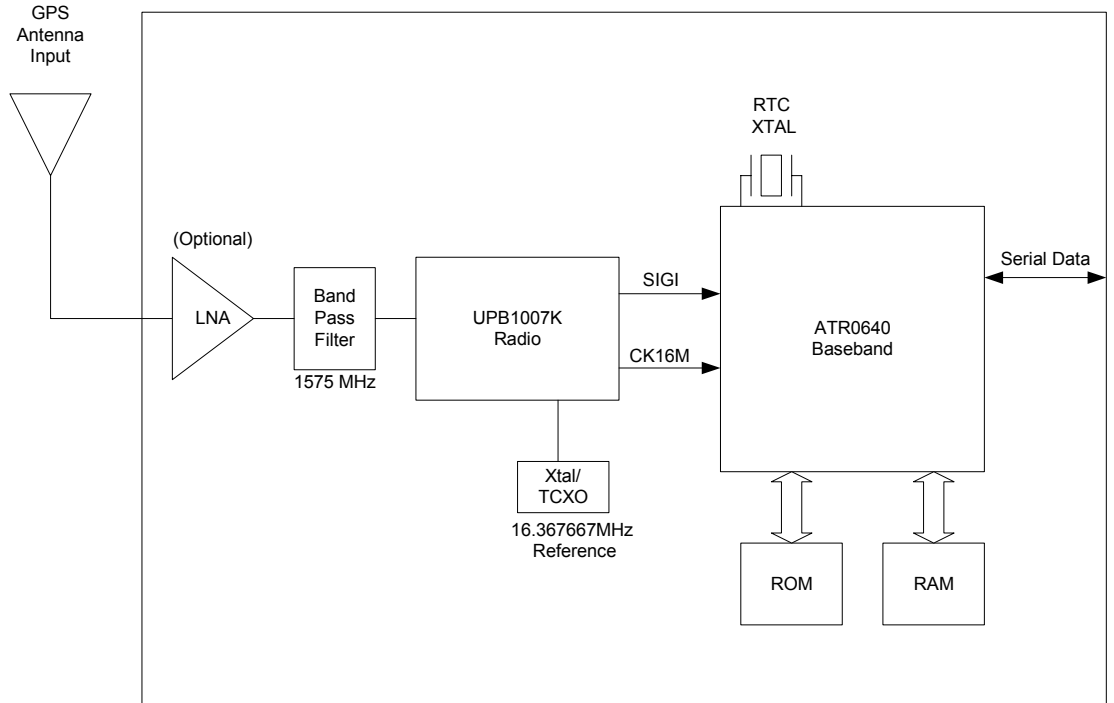

# ATR0640 [Preliminary]

ATR0640 Baseband Block Diagram

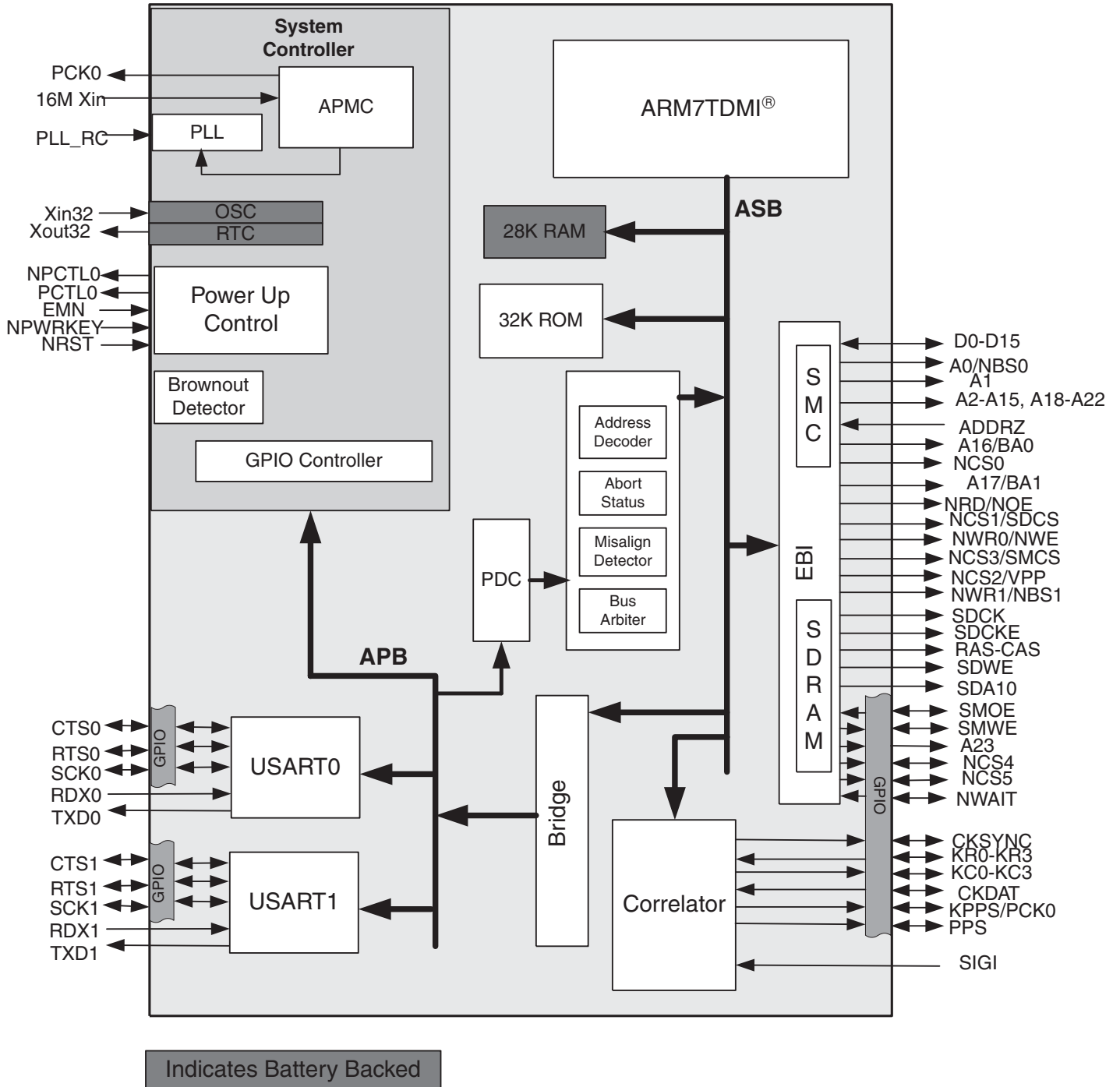



## Ordering Information

Extended Type Number	Remarks
ATR0640-EK	Baldur™ Evaluation Kit



## Atmel Corporation

2325 Orchard Parkway  
San Jose, CA 95131, USA  
Tel: 1(408) 441-0311  
Fax: 1(408) 487-2600

## Regional Headquarters

### Europe

Atmel Sarl  
Route des Arsenalux 41  
Case Postale 80  
CH-1705 Fribourg  
Switzerland  
Tel: (41) 26-426-5555  
Fax: (41) 26-426-5500

### Asia

Room 1219  
Chinachem Golden Plaza  
77 Mody Road Tsimshatsui  
East Kowloon  
Hong Kong  
Tel: (852) 2721-9778  
Fax: (852) 2722-1369

### Japan

9F, Tonetsu Shinkawa Bldg.  
1-24-8 Shinkawa  
Chuo-ku, Tokyo 104-0033  
Japan  
Tel: (81) 3-3523-3551  
Fax: (81) 3-3523-7581

## Atmel Operations

### Memory

2325 Orchard Parkway  
San Jose, CA 95131, USA  
Tel: 1(408) 441-0311  
Fax: 1(408) 436-4314

### Microcontrollers

2325 Orchard Parkway  
San Jose, CA 95131, USA  
Tel: 1(408) 441-0311  
Fax: 1(408) 436-4314

### La Chantrerie

BP 70602  
44306 Nantes Cedex 3, France  
Tel: (33) 2-40-18-18-18  
Fax: (33) 2-40-18-19-60

### ASIC/ASSP/Smart Cards

Zone Industrielle  
13106 Rousset Cedex, France  
Tel: (33) 4-42-53-60-00  
Fax: (33) 4-42-53-60-01

1150 East Cheyenne Mtn. Blvd.  
Colorado Springs, CO 80906, USA  
Tel: 1(719) 576-3300  
Fax: 1(719) 540-1759

Scottish Enterprise Technology Park  
Maxwell Building  
East Kilbride G75 0QR, Scotland  
Tel: (44) 1355-803-000  
Fax: (44) 1355-242-743

### RF/Automotive

Theresienstrasse 2  
Postfach 3535  
74025 Heilbronn, Germany  
Tel: (49) 71-31-67-0  
Fax: (49) 71-31-67-2340

1150 East Cheyenne Mtn. Blvd.  
Colorado Springs, CO 80906, USA  
Tel: 1(719) 576-3300  
Fax: 1(719) 540-1759

### Biometrics/Imaging/Hi-Rel MPU/ High Speed Converters/RF Datacom

Avenue de Rochepleine  
BP 123  
38521 Saint-Egreve Cedex, France  
Tel: (33) 4-76-58-30-00  
Fax: (33) 4-76-58-34-80

---

## Literature Requests

[www.atmel.com/literature](http://www.atmel.com/literature)

**Disclaimer:** The information in this document is provided in connection with Atmel products. No license, express or implied, by estoppel or otherwise, to any intellectual property right is granted by this document or in connection with the sale of Atmel products. **EXCEPT AS SET FORTH IN ATMEL'S TERMS AND CONDITIONS OF SALE LOCATED ON ATMEL'S WEB SITE, ATMEL ASSUMES NO LIABILITY WHATSOEVER AND DISCLAIMS ANY EXPRESS, IMPLIED OR STATUTORY WARRANTY RELATING TO ITS PRODUCTS INCLUDING, BUT NOT LIMITED TO, THE IMPLIED WARRANTY OF MERCHANTABILITY, FITNESS FOR A PARTICULAR PURPOSE, OR NON-INFRINGEMENT. IN NO EVENT SHALL ATMEL BE LIABLE FOR ANY DIRECT, INDIRECT, CONSEQUENTIAL, PUNITIVE, SPECIAL OR INCIDENTAL DAMAGES (INCLUDING, WITHOUT LIMITATION, DAMAGES FOR LOSS OF PROFITS, BUSINESS INTERRUPTION, OR LOSS OF INFORMATION) ARISING OUT OF THE USE OR INABILITY TO USE THIS DOCUMENT, EVEN IF ATMEL HAS BEEN ADVISED OF THE POSSIBILITY OF SUCH DAMAGES.** Atmel makes no representations or warranties with respect to the accuracy or completeness of the contents of this document and reserves the right to make changes to specifications and product descriptions at any time without notice. Atmel does not make any commitment to update the information contained herein. Atmel's products are not intended, authorized, or warranted for use as components in applications intended to support or sustain life.

© Atmel Corporation 2005. **All rights reserved.** Atmel®, logo and combinations thereof, Everywhere You Are® and others, are registered trademarks or trademarks of Atmel Corporation or its subsidiaries. Magellan® is a registered trademark of Thales Navigation. Other terms and product names may be trademarks of others.



Printed on recycled paper.

5105A-GPS-06/05