

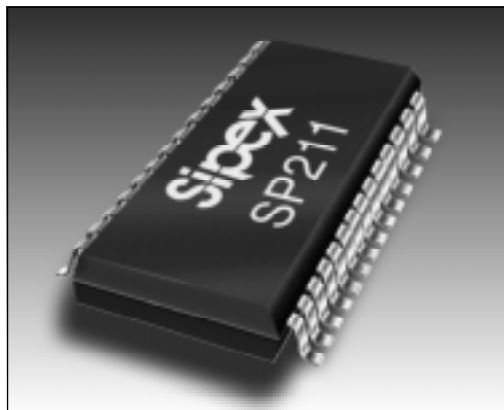

SP200/204/205/206/207/208/211/213

+5V High-Speed RS-232 Transceivers with 0.1μF Capacitors

- 0.1μF External Charge Pump Capacitors
- 120kbps Data Rate
- Standard SOIC and SSOP Packages
- Multiple Drivers and Receivers
- Single 5V Supply Operation
- 1μA Shutdown Mode
- WakeUp Feature in Shutdown Mode
- Tri-State Receiver Outputs
- Meets All RS-232 and V.28 Specifications
- Improved Driver Output Capacity for Mouse Applications
- ±10kV ESD Protection*



DESCRIPTION...

The **SP200 Series** are multi-channel RS-232 line transceivers in a variety of configurations to fit most communication needs. All models in this Series feature low-power CMOS construction and **Sipex** patented (5,306,954) on-board charge pump circuitry to generate the ±10V RS-232 voltage levels, using 0.1μF charge pump capacitors to save board space and reduce circuit cost. The **SP200**, **SP205**, **SP206**, **SP207B**, **SP211** and **SP213** models feature a low-power shutdown mode, which reduces power supply drain to 1μA. A WakeUp function keeps the receivers active in the shutdown mode.

Model	Number of RS-232		No. of Receivers Active in Shutdown	No. of External 0.1μF Capacitors	Shutdown	WakeUp	TTL Tri-State
	Drivers	Receivers					
SP200	5	0	0	4	Yes	No	No
SP204	4	0	0	4	No	No	No
SP205	5	5	0	None	Yes	No	Yes
SP205B	5	5	5	None	Yes	Yes	Yes
SP206	4	3	0	4	Yes	No	Yes
SP206B	4	3	3	4	Yes	Yes	Yes
SP207	5	3	0	4	No	No	No
SP207B	5	3	3	4	Yes	Yes	Yes
SP208	4	4	0	4	No	No	No
SP211	4	5	0	4	Yes	No	Yes
SP211B	4	5	5	4	Yes	Yes	Yes
SP213	4	5	2	4	Yes	Yes	Yes

Table 1. Model Selection Table

*All driver outputs and receiver inputs characterized per MIL-STD-883C Method 3015.7

ABSOLUTE MAXIMUM RATINGS

These are stress ratings only and functional operation of the device at these or any other above those indicated in the operation sections of the specifications below is not implied. Exposure to absolute maximum rating conditions for extended periods of time may affect reliability.

V_{CC}	+6V
V^+	$(V_{CC} - 0.3V)$ to +13.2V
V^-	13.2V
Input Voltages	
T_{IN}	-0.3V to $(V_{CC} + 0.3V)$
R_{IN}	$\pm 20V$
Output Voltages	
T_{OUT}	$(V^+, +0.3V)$ to $(V^-, -0.3V)$
R_{OUT}	-0.3V to $(V_{CC} + 0.3V)$
Short Circuit Duration on T_{OUT}	
Power Dissipation	
Plastic DIP	375mW
(derate 7mW/°C above +70°C)	
Small Outline	375mW
(derate 7mW/°C above +70°C)	

SPECIFICATIONS

V_{CC} at nominal ratings; 0.1 μ F charge pump capacitors; T_{MIN} to T_{MAX} unless otherwise noted.

PARAMETER	MIN.	TYP.	MAX.	UNIT	CONDITIONS
TTL INPUTS					T_{IN} , EN, SD
Logic Threshold			0.8	Volts	
V_{IL}	2.0			Volts	
V_{IH}		15	200	μ A	$T_{IN} = 0V$
Logic Pullup Current				kbps	$C_L = 2,500pF, R_L = 3k\Omega$
Maximum Data Rate	120				
TTL OUTPUTS					
Compatibility		TTL/CMOS			
V_{OL}	3.5		0.4	Volts	$I_{OUT} = 3.2mA; V_{CC} = +5V$
V_{OH}				Volts	$I_{OUT} = -1.0mA$
Leakage Current		0.05	± 10	μ A	EN = V_{CC} ; $0V \leq V_{OUT} \leq V_{CC}$; $T_A = +25^\circ C$
RS-232 OUTPUT					
Output Voltage Swing	± 5	± 7		Volts	All transmitter outputs loaded with 3k Ω to ground
Output Resistance	300			Ohms	$V_{CC} = 0V; V_{OUT} = \pm 2V$
Output Short Circuit Current		± 25		mA	Infinite duration
RS-232 INPUT					
Voltage Range	-15		+15	Volts	
Voltage Threshold					
LOW	0.8	1.2		Volts	$V_{CC} = 5V, T_A = +25^\circ C$
HIGH		1.7	2.4	Volts	$V_{CC} = 5V, T_A = +25^\circ C$
Hysteresis	0.2	0.5	1.0	Volts	$V_{CC} = +5V$
Resistance	3	5	7	k Ω	$\pm 15V; T_A = +25^\circ C$
DYNAMIC CHARACTERISTICS					
Propagation Delay		1.5		μ s	RS-232-to-TTL
Instantaneous Slew Rate			30	V/ μ s	$C_L = 50pF, R_L = 3-7k\Omega;$ $T_A = +25^\circ C$
Transition Region Slew Rate		5		V/ μ s	$C_L = 2,500pF, R_L = 3k\Omega;$ measured from +3V to -3V or -3V to +3V
Output Enable Time		400		ns	
Output Disable Time		250		ns	

SPECIFICATIONS

V_{CC} at nominal ratings; 0.1 μ F charge pump capacitors; T_{MIN} to T_{MAX} , unless otherwise noted.

PARAMETER	MIN.	TYP.	MAX.	UNIT	CONDITIONS
POWER REQUIREMENTS					
V_{CC} SP200, SP205, SP207 and SP207B	4.75	5.00	5.25	Volts	$T_A = +25^\circ\text{C}$ No load; $V_{CC} = \pm 10\%$ All transmitters $R_L = 3k\Omega$ $T_A = +25^\circ\text{C}$
All other parts	4.50	5.00	5.50	Volts	
I_{CC}		4	10	mA	
Shutdown Current		20	10	mA	
		1	10	μ A	
ENVIRONMENTAL AND MECHANICAL					
Operating Temperature					
Commercial, -C	0		+70	$^\circ\text{C}$	
Extended, -E	-40		+85	$^\circ\text{C}$	
Storage Temperature	-65		+125	$^\circ\text{C}$	
Package					
-A		Shrink (SSOP) small outline			
-T		Wide (SOIC) small outline			

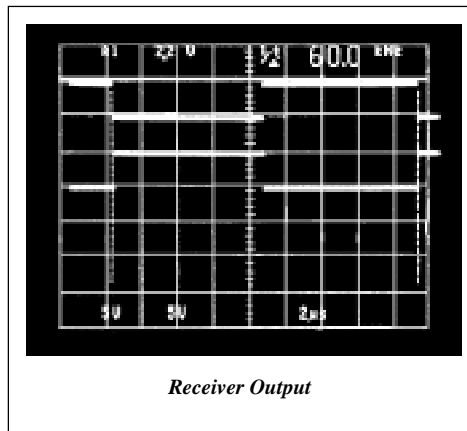
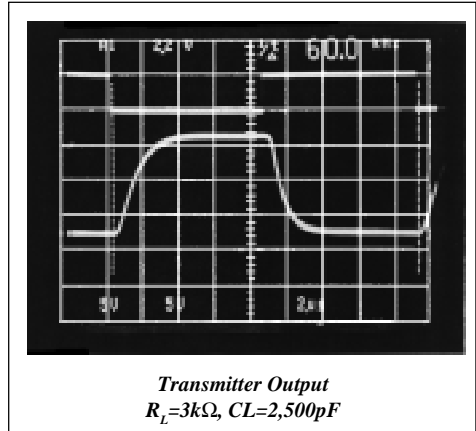
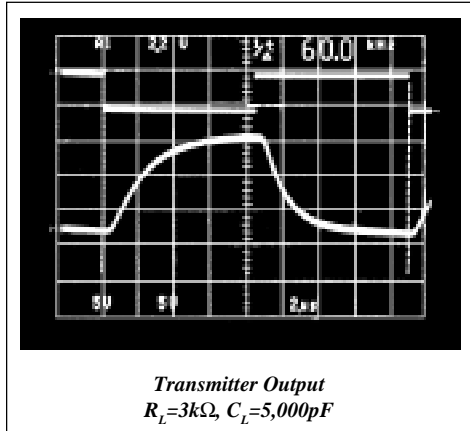

PINOUT

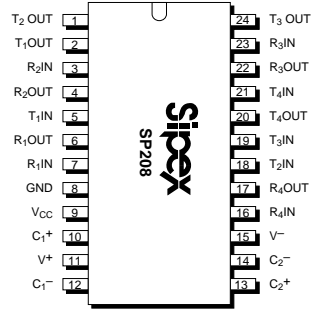
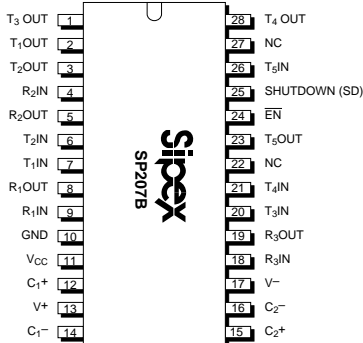
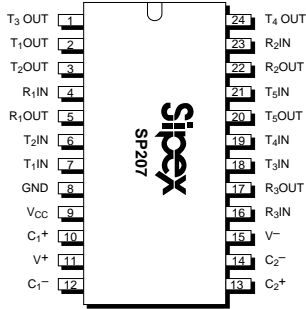
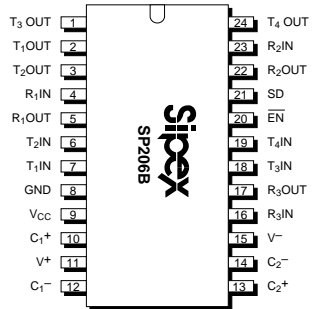
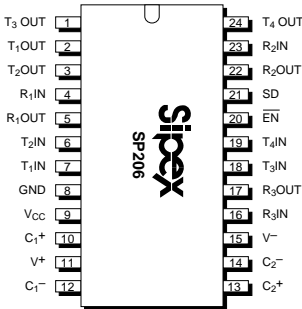
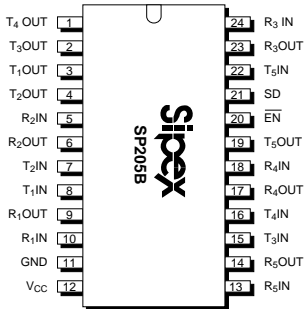
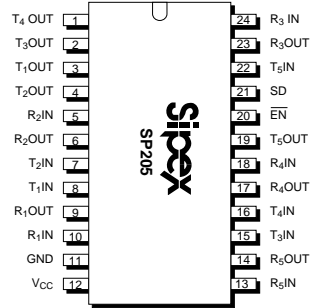
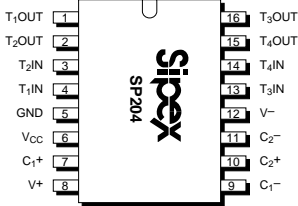
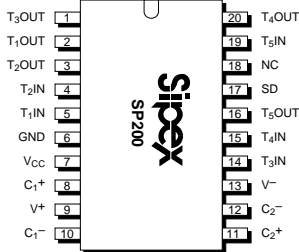

PINOUT

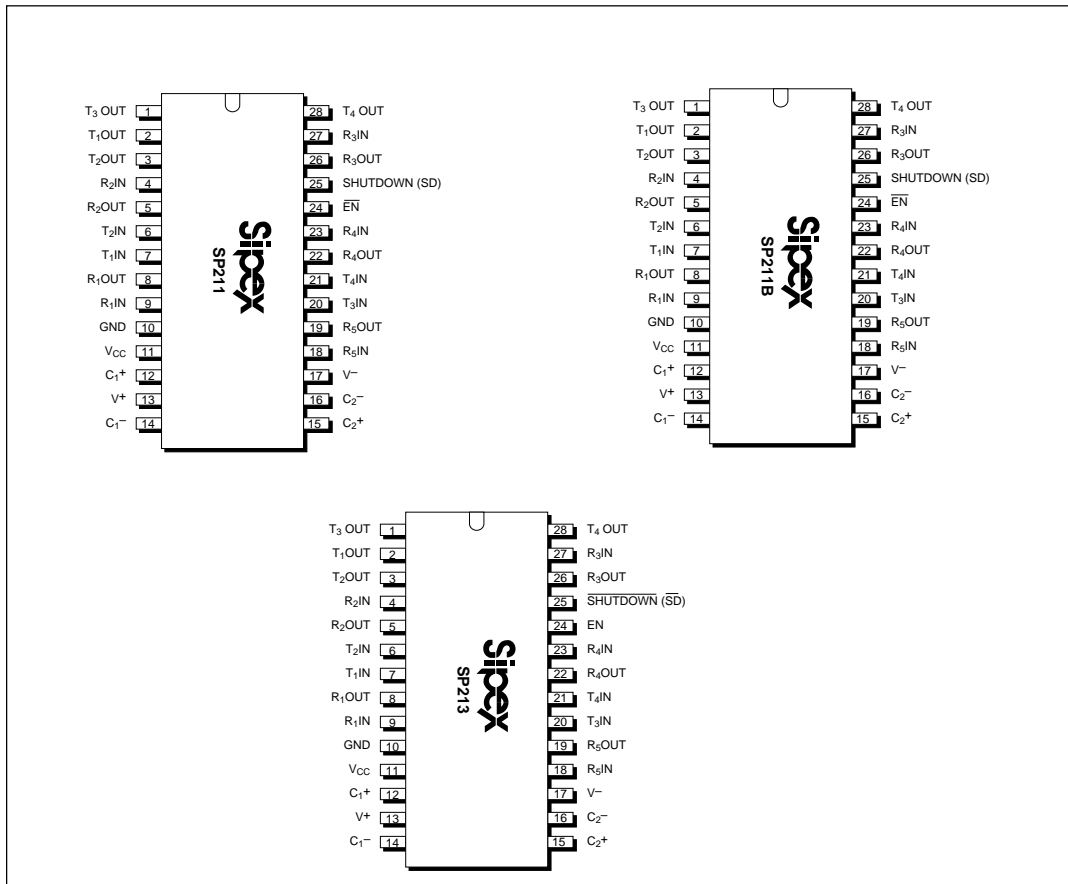

FEATURES...

The **SP200 Series** multi-channel RS-232 line transceivers provide a variety of configurations to fit most communication needs, especially those applications where $\pm 12\text{V}$ is not available. All models in this Series feature low-power CMOS construction and **Sipex** proprietary on-board charge pump circuitry to generate the $\pm 10\text{V}$ RS-232 voltage levels. The ability to use $0.1\mu\text{F}$ charge pump capacitors saves board space and reduces circuit cost. Different models within the Series provide different driver/receiver combinations to match any application requirement.

The **SP200**, **SP205**, **SP206**, **SP207B**, **SP211** and **SP213** models feature a low-power shutdown mode, which reduces power supply drain to $1\mu\text{A}$. The WakeUp function keeps the receive-

rs active in the shutdown mode, unless disabled by the EN pin. Models with a “B” suffix are equipped with the WakeUp function.

Models in the Series are available in 28-pin SO (wide) and SSOP (shrink) small outline packages. Devices can be specified for commercial (0°C to $+70^\circ\text{C}$) and industrial/extended (-40°C to $+85^\circ\text{C}$) operating temperatures.

THEORY OF OPERATION

Charge-Pump

The charge pump is a **Sipex** patented design (5,306,954) and uses a unique approach compared to older less-efficient designs. The charge pump still requires four external capacitors, but uses a four-phase voltage shifting technique to

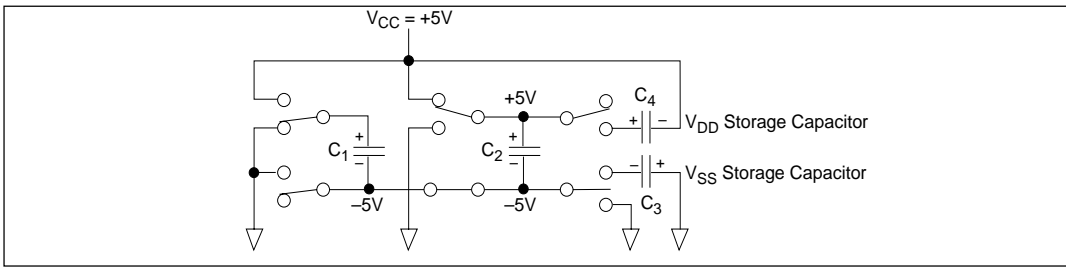

Figure 1. Charge Pump — Phase 1

attain symmetrical $\pm 10\text{V}$ power supplies. Figure 3a shows the waveform found on the positive side of capacitor C_2 , and Figure 3b shows the negative side of capacitor C_2 . There is a free-running oscillator that controls the four phases of the voltage shifting. A description of each phase follows.

Phase 1

— V_{SS} charge storage — During this phase of the clock cycle, the positive side of capacitors C_1 and C_2 are initially charged to $+5\text{V}$. C_1^+ is then switched to ground and the charge in C_1^- is transferred to C_2^- . Since C_2^+ is connected to $+5\text{V}$, the voltage potential across capacitor C_2 is now 10V .

Phase 2

— V_{SS} transfer — Phase two of the clock connects the negative terminal of C_2 to the V_{SS} storage capacitor and the positive terminal of C_2 to ground, and transfers the generated -10V to C_3 . Simultaneously, the positive side of capacitor C_1 is switched to $+5\text{V}$ and the negative side is connected to ground.

Phase 3

— V_{DD} charge storage — The third phase of the clock is identical to the first phase — the charge

transferred in C_1 produces -5V in the negative terminal of C_1 , which is applied to the negative side of capacitor C_2 . Since C_2^+ is at $+5\text{V}$, the voltage potential across C_2 is 10V .

Phase 4

— V_{DD} transfer — The fourth phase of the clock connects the negative terminal of C_2 to ground, and transfers the generated 10V across C_2 to C_4 , the V_{DD} storage capacitor. Again, simultaneously with this, the positive side of capacitor C_1 is switched to $+5\text{V}$ and the negative side is connected to ground, and the cycle begins again.

Since both V^+ and V^- are separately generated from V_{CC} ; in a no-load condition V^+ and V^- will be symmetrical. Older charge pump approaches that generate V^- from V^+ will show a decrease in the magnitude of V^- compared to V^+ due to the inherent inefficiencies in the design.

The clock rate for the charge pump typically operates at 15kHz . The external capacitors can be as low as $0.1\mu\text{F}$ with a 16V breakdown voltage rating.

The **SP200 Series** devices are made up of three basic circuit blocks — 1) transmitter/driver, 2) receiver and 3) the **Sipex** proprietary charge

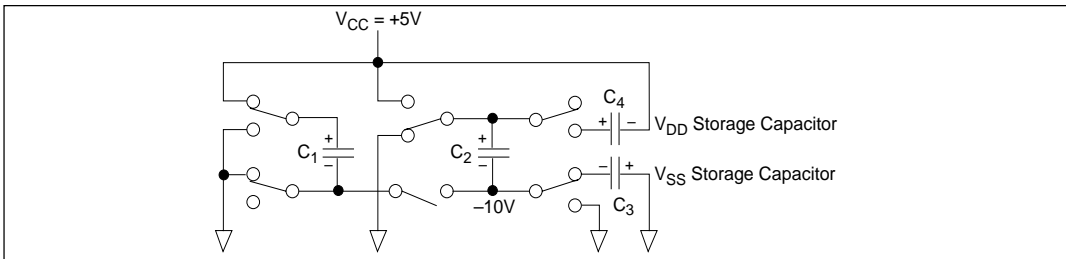

Figure 2. Charge Pump — Phase 2

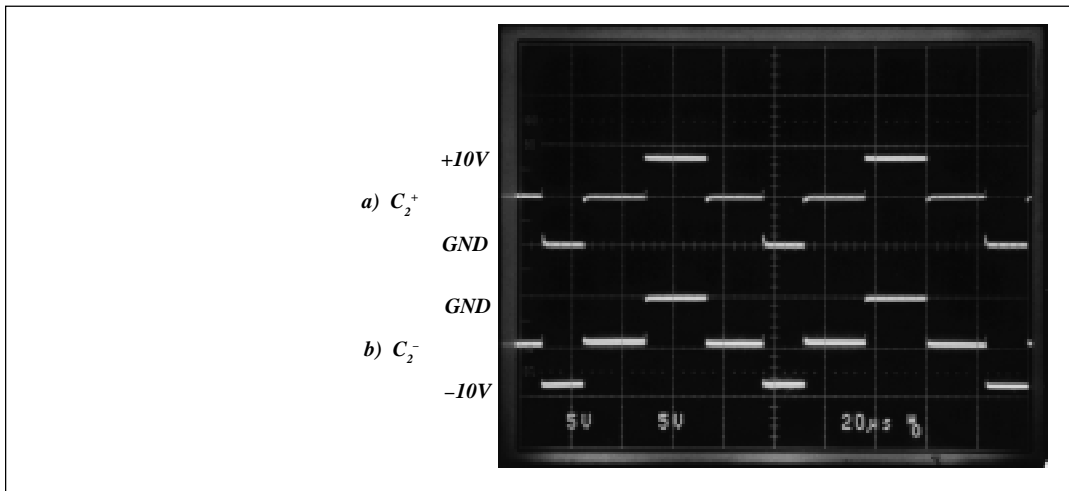

Figure 3. Charge Pump Waveforms

pump. Each model within the Series incorporates variations of these circuits to achieve the desired configuration and performance.

Transmitter/Driver

The drivers are inverting transmitters, which accept either TTL or CMOS inputs and output the RS-232 signals with an inverted sense relative to the input logic levels. Typically, the RS-232 output voltage swing is $\pm 9V$ with no load, and $\pm 5V$ minimum with full load. The transmitter outputs are protected against infinite short-circuits to ground without degradation in reliability. The drivers of the **SP200**, **SP205**, **SP205B**, **SP206**, **SP206B**, **SP207B**, **SP211**, **SP211B** and **SP213** can be tri-stated by using the SHUTDOWN function.

In the “power off” state, the output impedance will remain greater than 300 Ohms, again satisfying the RS-232 specifications. Should the input of the

driver be left open, an internal 400kOhm pullup resistor to V_{CC} forces the input high, thus committing the output to a low state. The slew rate of the transmitter output is internally limited to a maximum of $30V/\mu s$ in order to meet the EIA standards (EIA RS-232D 2.1.7, Paragraph 5). The transition of the loaded output from high to low also meets the monotonicity requirements of the standard.

Receivers

The receivers convert RS-232 input signals to inverted TTL signals. Since the input is usually from a transmission line where long cable lengths and system interference can degrade the signal, the inputs have a typical hysteresis margin of 500mV. This ensures that the receiver is virtually immune to noisy transmission lines. Should an input be left unconnected, a 5kOhm pulldown resistor to ground will commit the output of the receiver to a high state.

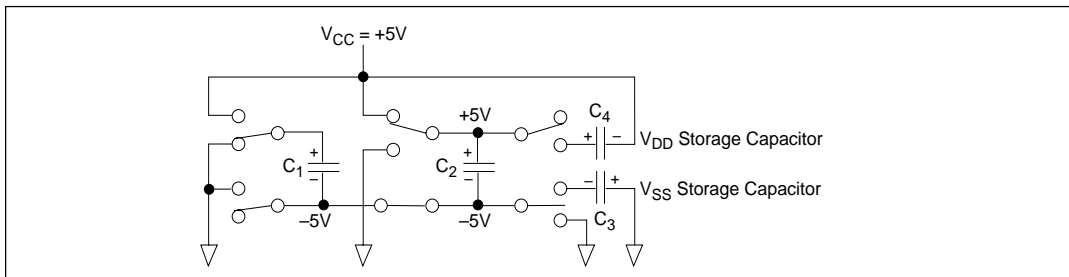

Figure 4. Charge Pump — Phase 3

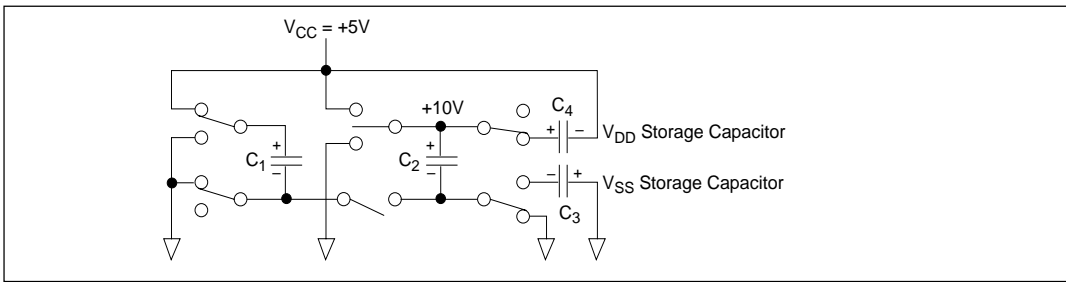

Figure 5. Charge Pump — Phase 4

SHUTDOWN MODE

The **SP200**, **SP205**, **SP205B**, **SP206**, **SP206B**, **SP207B**, **SP211**, **SP211B** and **SP213** all feature a control input which will disable the device and reduce the power supply current to less than 10µA, making the parts ideal for battery-powered systems. In the “shutdown” mode the receivers and transmitters will both be tri-stated. The V⁺ output of the charge pump will discharge to V_{CC}, and the V⁻ output will discharge to ground. Products with the WakeUp function can enable or disable the receivers during shutdown.

For complete shutdown to occur and the 10µA power drain to be realized, the following conditions must be met:

SP200, **SP205/B**, **SP206/B**, **SP207B** and **SP211/B**:

- +5V must be applied to the SD pin
- $\overline{\text{ENABLE}}$ must be either 0V, +5.0V or not connected
- the transmitter inputs must be either +5.0V or not connected
- V_{CC} must be +5V
- Receiver inputs must be >0V and <+5V

SP213:

- 0V must be applied to the $\overline{\text{SD}}$ pin
- ENABLE must be either 0V, +5.0V or not connected
- the transmitter inputs must be either +5.0V or not connected
- V_{CC} must be +5V
- Receiver inputs must be >0V and <+5V

ENABLE

The **SP205/B**, **SP206/B**, **SP207/B**, **SP211** and **SP213** all feature an enable input, which allows the receiver outputs to be either tri-stated or enabled. This can be especially useful when the receiver is tied directly to a microprocessor data bus. For the **SP205/B**, **SP206/B**, **SP207/B** and **SP211**, enable is active low; that is, 0V applied to the $\overline{\text{ENABLE}}$ pin will enable the receiver outputs. For the **SP213**, enable is active high; that is, +5V applied to the ENABLE pin will enable the receiver outputs.

WAKEUP FUNCTION

The **SP205B**, **SP206B**, **SP207B**, **SP211B** and **SP213** have a wake-up feature that keeps two or more receivers in an enabled state when the device is in the shutdown mode. The **SP213** has two receivers active (R₄ and R₅), while the **SP205B**, **SP207B** and **SP211B** have all receivers active during shutdown. With only the receivers active during shutdown, the devices draw 5–10µA of supply current.

SD	$\overline{\text{EN}}$	SP213 Only		Power Up/Down	Receiver Outputs
		SD	EN		
0	0	1	1	Up	Enable
0	1	1	0	Up	Tri-state
1	0	0	1	Down	Enable
1	1	0	0	Down	Tri-state

Table 2. Wake-Up Truth Table

A typical application of this function would be where a modem is interfaced to a computer in a power-down mode. The ring indicator signal from the modem could be passed through an active receiver in the **SP2XXB/SP213** that is itself in the shutdown mode. The ring indicator signal would propagate through the **SP2XXB/SP213** to the power management circuitry of the

computer to power up the microprocessor and the **SP2XXB/SP213** drivers. After the supply voltage to the **SP2XXB/SP213** reaches +5.0V, the SHUTDOWN pin can be disabled, taking the **SP2XXB/SP213** out of the shutdown mode.

All receivers that are active during shutdown maintain 500mV (typ.) of hysteresis.

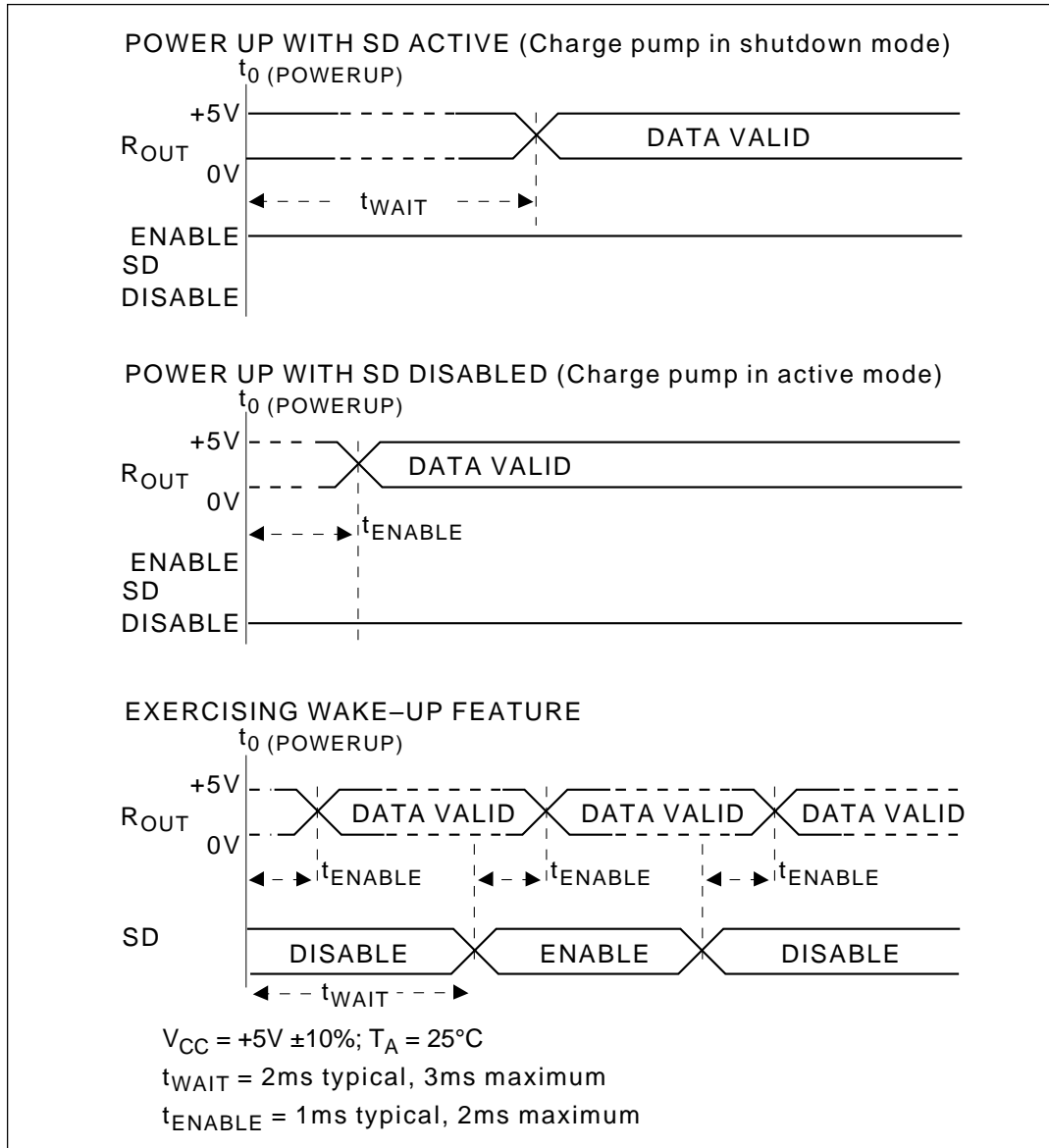

Figure 6. Wake-Up Timing

Specification	RS-232D	RS-423A	RS-422	RS-485	RS-562
Mode of Operation	Single-Ended	Single-Ended	Differential	Differential	Single-Ended
No. of Drivers and Receivers Allowed on One Line	1 Driver 1 Receiver	1 Driver 10 Receivers	1 Driver 10 Receivers	32 Drivers 32 Receivers	1 Driver 1 Receiver
Maximum Cable Length	50 feet	4,000 feet	4,000 feet	4,000 feet	$C \leq 2,500\text{pF}$ @ <20kbps; $C \leq 1,000\text{pF}$ @ >20kbps
Maximum Data Rate	20kbps	100kbps	10Mbps	10Mbps	64kbps
Driver output Maximum Voltage	$\pm 25\text{V}$	$\pm 6\text{V}$	-0.25V to $+6\text{V}$	-7V to $+12\text{V}$	-3.7V to $+13.2\text{V}$
Driver Output Signal Level Loaded Unloaded	$\pm 5\text{V}$ $\pm 15\text{V}$	$\pm 3.6\text{V}$ $\pm 6\text{V}$	$\pm 2\text{V}$ $\pm 5\text{V}$	$\pm 1.5\text{V}$ $\pm 5\text{V}$	$\pm 3.7\text{V}$ $\pm 13.2\text{V}$
Driver Load Impedance	3 – 7kohm	450 ohm	100 ohm	54 ohm	3–7kohm
Max. Driver Output Current (High Impedance State) Power On Power Off	$V_{\text{MAX}}/300$	100 μA	$\pm 100\mu\text{A}$	$\pm 100\mu\text{A}$ $\pm 100\mu\text{A}$	
Slew Rate	30V/ μs max.	Controls Provided			30V/ μs max.
Receiver Input Voltage Range	$\pm 15\text{V}$	$\pm 12\text{V}$	-7V to $+7\text{V}$	-7V to $+12\text{V}$	$\pm 15\text{V}$
Receiver Input Sensitivity	$\pm 3\text{V}$	$\pm 200\text{mV}$	$\pm 200\text{mV}$	$\pm 200\text{mV}$	$\pm 3\text{V}$
Receiver Input Resistance	3–7kohm	4kohm min.	4kohm min.	12kohm min.	3–7kohm

Table 3. EIA Standard Definitions

EIA STANDARDS

The Electronic Industry Association (EIA) developed several standards of data transmission which are revised and updated in order to meet the requirements of the industry. In data processing, there are two basic means of communicating between systems and components. The RS-232 standard was first introduced in 1962 and, since that time, has become an industry standard.

The RS-232 is a relatively slow data exchange protocol, with a maximum baud rate of only 20kbaud, which can be transmitted over a maximum copper wire cable length of 50 feet. The **SP200** through **SP213** Series of data communications interface products have been designed

to meet both the EIA protocol standards, and the needs of the industry.

$\pm 10\text{kV}$ ESD PROTECTION

The **SP200** Series is equipped with **Sipex**-proprietary ESD protection circuitry on all RS-232 inputs and outputs. The **SP200** Series has been characterized using MIL-STD-883C Method 3015.7 Human Body Model. Each device in the family can withstand up to $\pm 10\text{kV}$ of static discharge on all RS-232 inputs and outputs. All other pins of each device will maintain $\geq \pm 2\text{kV}$ of ESD protection.

TYPICAL APPLICATION CIRCUITS

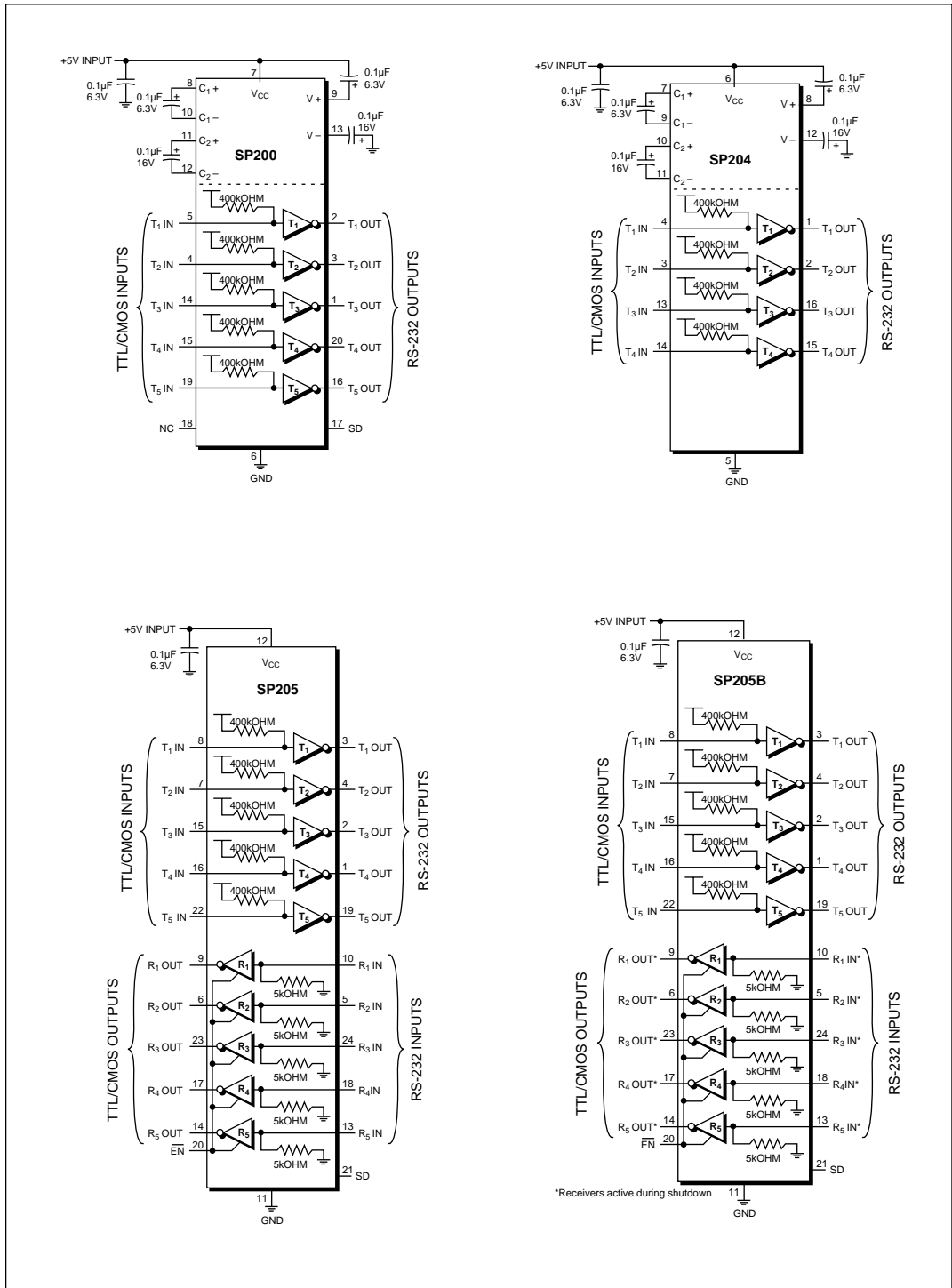

TYPICAL APPLICATION CIRCUITS

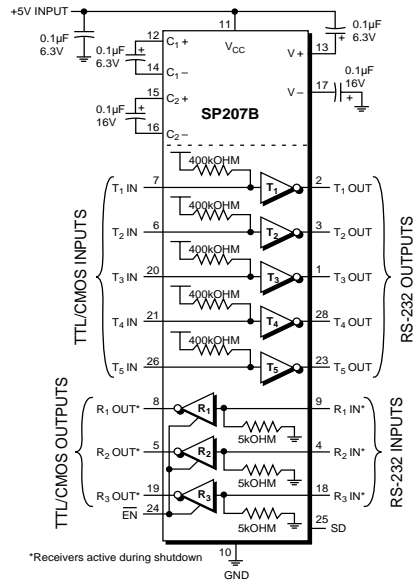
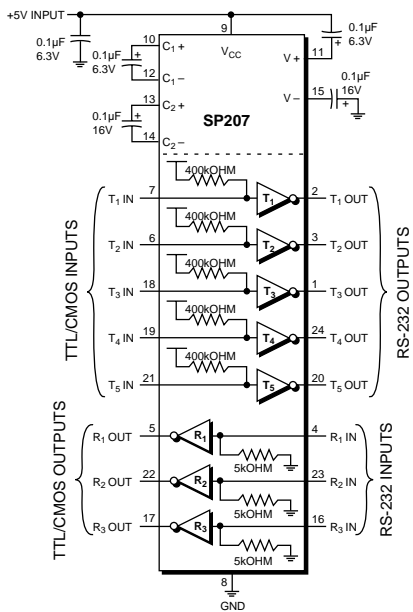
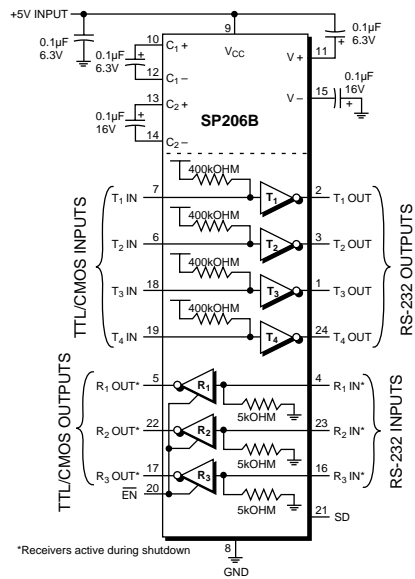
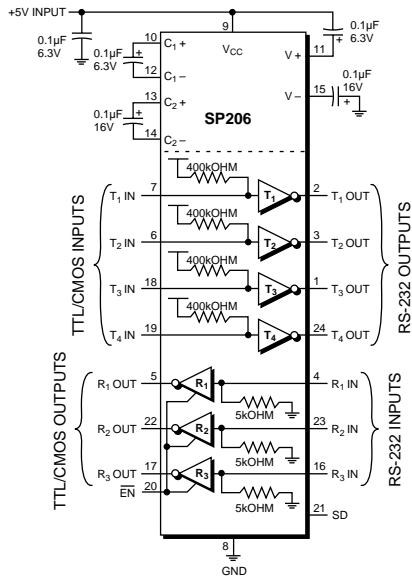

The SP207B is offered in a 28-pin SOIC or 28-pin SSOP package.

TYPICAL APPLICATION CIRCUITS

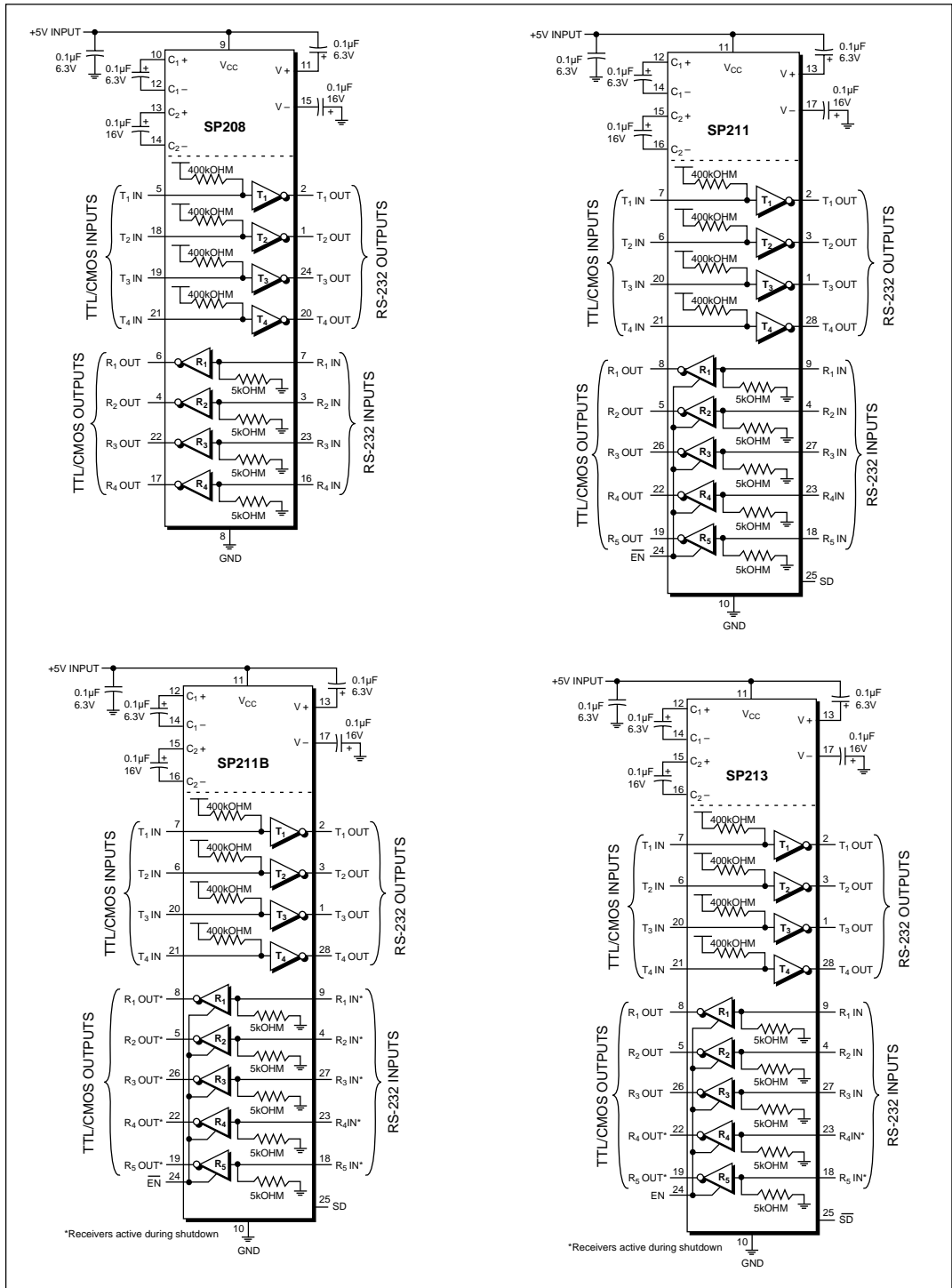

ORDERING INFORMATION

RS-232 Transceivers:

Model	Drivers	Receivers	Temperature Range	Package Type
SP207CA	5	3	0°C to +70°C	24-pin SSOP
SP207CP	5	3	0°C to +70°C	24-pin Plastic DIP
SP207CT	5	3	0°C to +70°C	24-pin SOIC
SP207EA	5	3	-40°C to +85°C	24-pin SSOP
SP207EP	5	3	-40°C to +85°C	24-pin Plastic DIP
SP207ET	5	3	-40°C to +85°C	24-pin SOIC
SP208CA	4	4	0°C to +70°C	24-pin SSOP
SP208CP	4	4	0°C to +70°C	24-pin Plastic DIP
SP208CT	4	4	0°C to +70°C	24-pin SOIC
SP208EA	4	4	-40°C to +85°C	24-pin SSOP
SP208EP	4	4	-40°C to +85°C	24-pin Plastic DIP
SP208ET	4	4	-40°C to +85°C	24-pin SOIC

RS-232 Transmitters:

Model	Drivers	Receivers	Temperature Range	Package Type
SP204CP	4	0	0°C to +70°C	16-pin Plastic DIP
SP204CT	4	0	0°C to +70°C	16-pin SOIC
SP204EP	4	0	-40°C to +85°C	16-pin Plastic DIP
SP204ET	4	0	-40°C to +85°C	16-pin SOIC

RS-232 Transmitters with Low-Power Shutdown:

Model	Drivers	Receivers	Temperature Range	Package Type
SP200CP	5	0	0°C to +70°C	20-pin Plastic DIP
SP200CT	5	0	0°C to +70°C	20-pin SOIC
SP200EP	5	0	-40°C to +85°C	20-pin Plastic DIP
SP200ET	5	0	-40°C to +85°C	20-pin SOIC

RS-232 Transceivers with Low-Power Shutdown and Tri-state Enable:

Model	Drivers	Receivers	Temperature Range	Package Type
SP205CP	5	5	0°C to +70°C	24-pin Plastic Double-Width DIP
SP205EP	5	5	-40°C to +85°C	24-pin Plastic Double-Width DIP
SP206CA	4	3	0°C to +70°C	24-pin SSOP
SP206CP	4	3	0°C to +70°C	24-pin Plastic DIP
SP206CT	4	3	0°C to +70°C	24-pin SOIC
SP206EA	4	3	-40°C to +85°C	24-pin SSOP
SP206EP	4	3	-40°C to +85°C	24-pin Plastic DIP
SP206ET	4	3	-40°C to +85°C	24-pin SOIC
SP211CA	4	5	0°C to +70°C	28-pin SSOP
SP211CT	4	5	0°C to +70°C	28-pin SOIC
SP211EA	4	5	-40°C to +85°C	28-pin SSOP
SP211ET	4	5	-40°C to +85°C	28-pin SOIC

ORDERING INFORMATION

RS-232 Transceivers with Low-Power Shutdown, Tri-state Enable, and Wake-Up Function:

Model	Drivers	Receivers	Temperature Range	Package Type
SP205BCP	5	5, with 5 active in Shutdown	0°C to +70°C	24-pin Plastic Double-Width DIP
SP205BEP	5	5, with 5 active in Shutdown	-40°C to +85°C	24-pin Plastic Double-Width DIP
SP206BCA	4	3, with 3 active in Shutdown	0°C to +70°C	24-pin SSOP
SP206BCP	4	3, with 3 active in Shutdown	0°C to +70°C	24-pin Plastic DIP
SP206BCT	4	3, with 3 active in Shutdown	0°C to +70°C	24-pin SOIC
SP206BEA	4	3, with 3 active in Shutdown	-40°C to +85°C	24-pin SSOP
SP206BEP	4	3, with 3 active in Shutdown	-40°C to +85°C	24-pin Plastic DIP
SP206BET	4	3, with 3 active in Shutdown	-40°C to +85°C	24-pin SOIC
SP207BCA	5	3, with 3 active in Shutdown	0°C to +70°C	28-pin SSOP
SP207BCT	5	3, with 3 active in Shutdown	0°C to +70°C	28-pin SOIC
SP207BEA	5	3, with 3 active in Shutdown	-40°C to +85°C	28-pin SSOP
SP207BET	5	3, with 3 active in Shutdown	-40°C to +85°C	28-pin SOIC
SP211BCA	4	5, with 5 active in Shutdown	0°C to +70°C	28-pin SSOP
SP211BCT	4	5, with 5 active in Shutdown	0°C to +70°C	28-pin SOIC
SP211BEA	4	5, with 5 active in Shutdown	-40°C to +85°C	28-pin SSOP
SP211BET	4	5, with 5 active in Shutdown	-40°C to +85°C	28-pin SOIC
SP213CA	4	5, with 2 active in Shutdown	0°C to +70°C	28-pin SSOP
SP213CT	4	5, with 2 active in Shutdown	0°C to +70°C	28-pin SOIC
SP213EA	4	5, with 2 active in Shutdown	-40°C to +85°C	28-pin SSOP
SP213ET	4	5, with 2 active in Shutdown	-40°C to +85°C	28-pin SOIC



SIGNAL PROCESSING EXCELLENCE

Sipex Corporation

Headquarters and Sales Office

22 Linnell Circle
 Billerica, MA 01821
 TEL: (978) 667-8700
 FAX: (978) 670-9001
 e-mail: sales@sipex.com

Sales Office

233 South Hillview Drive
 Milpitas, CA 95035
 TEL: (408) 934-7500
 FAX: (408) 935-7600

Sipex Corporation reserves the right to make changes to any products described herein. Sipex does not assume any liability arising out of the application or use of any product or circuit described hereing; neither does it convey any license under its patent rights nor the rights of others.