

# ZWS-AF-SERIES

Single output 50W ~ 150W

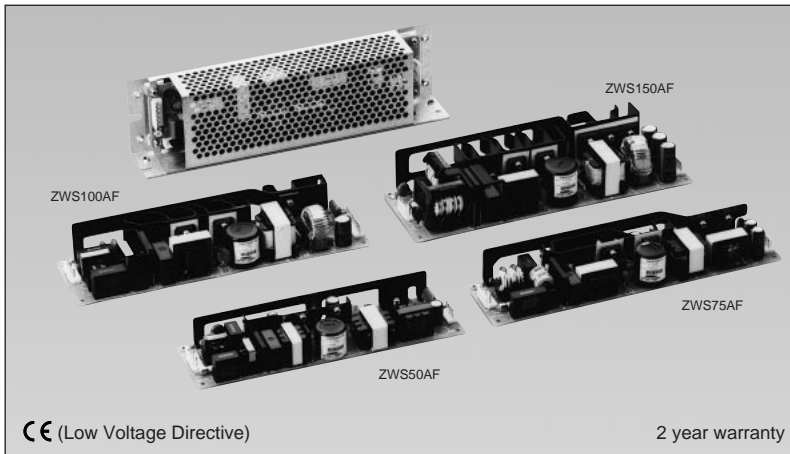

## Model name

**ZWS 100AF-5/**

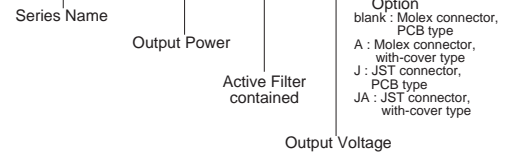

## Features

- CE marking (Low Voltage Directive)
- Active Filter contained, PFHC type
- Applicable to peak output wattage 120% (12V, 15V, 24V output)
- Low leakage current 0.5mA max
- Equipped with Remote ON/OFF control (with-cover type excluded) and output variable voltage
- 2 year warranty

PC Board Type Power Supply

## Specifications

1. Input voltage range	85~265VAC (47~63Hz) , 120~370VDC universal input
2. Power factor	0.99 (typ) 100VAC at full load, 0.95(typ) 200VAC at full load
3. Output Voltage range	± 10%
4. Cooling	Convection cooling or Forced air cooling
5. Operating ambient temperature (Standard mounting)	ZWS50AF,75AF, Convection cooling -10°C~+50°C:100%,+60°C:70% (with cover:-10°C~+40°C:100%,+50°C:70%) Forced air cooling -10°C~+60°C:100%,+70°C:70% (with cover:-10°C~+50°C:100%,+60°C:70%)
	ZWS100AF Convection cooling -10°C~+50°C:100%,+60°C:60% (with cover:-10°C~+40°C:100%,+50°C:60%) Forced air cooling -10°C~+60°C:100%,+70°C:70% (with cover:-10°C~+50°C:100%,+60°C:70%)
	ZWS150AF Convection cooling -10°C~+40°C:100%,+60°C:50% (with cover:-10°C~+30°C:100%,+45°C:50%) Forced air cooling -10°C~+50°C:100%,+60°C:70% (with cover:-10°C~+40°C:100%,+50°C:70%)
6. Withstand voltage	Input-output : 3kVAC (20mA) , Input-FG : 2kVAC (20mA) , Output-FG : 500VAC (100mA) for 1 min
7. Safety standard	Approved by UL1950 , CSA950(C-UL) , EN60950(TUV)  and EN50178(TUV)
8. CE marking	Conforms to Low Voltage Directive
9. EMI	Meets to EN55011-B,EN55022,FCC-B,VCCI-B
10. Immunity	Meets to EN50082-2(EN61000-4-2,-3,-4,-5,-6,-7,-8,-11)
11. PFHC	Meets to EN61000-3-2
12. Functions	Over voltage protection,Over current protection,Remote on/off control(for open frame type only)

## Product lineup

Model name	Nominal output voltage	Max. output current	Note 1		Note 1		UL	CSA	EN
			Max. peak output current	Max. average output power	Max. peak output power				
ZWS50AF	ZWS50AF-5	5V	10A	-	50.0W	-	○	○	○
	ZWS50AF-12	12V	4.3A	5.2A	51.6W	62.4W	○	○	○
	ZWS50AF-15	15V	3.5A	4.2A	52.5W	63.0W	○	○	○
	ZWS50AF-24	24V	2.1A	2.6A	50.4W	62.4W	○	○	○
ZWS75AF	ZWS75AF-5	5V	15A	-	75.0W	-	○	○	○
	ZWS75AF-12	12V	6.3A	7.5A	75.6W	90.0W	○	○	○
	ZWS75AF-15	15V	5.0A	6.0A	75.0W	90.0W	○	○	○
	ZWS75AF-24	24V	3.2A	3.8A	76.8W	91.8W	○	○	○
ZWS100AF	ZWS100AF-5	5V	20A	-	100.0W	-	○	○	○
	ZWS100AF-12	12V	8.5A	10A	102.0W	120.0W	○	○	○
	ZWS100AF-15	15V	6.7A	8.0A	100.5W	120.0W	○	○	○
	ZWS100AF-24	24V	4.3A	5.0A	103.2W	120.0W	○	○	○
ZWS150AF	ZWS150AF-5	5V	30A	-	150.0W	-	○	○	○
	ZWS150AF-12	12V	12.5A	15A	150.0W	180.0W	○	○	○
	ZWS150AF-15	15V	10A	12A	150.0W	180.0W	○	○	○
	ZWS150AF-24	24V	6.3A	7.5A	151.2W	180.0W	○	○	○

Note1 : Duration at peak current : 10 seconds max. within Max. average output power.  
 ●Based on the data under normal installation and without cover type. Needs output derating according to installation method or ambient temperature condition.

○ : Safety standard approved



# ZWS-AF-SERIES

## ■ ZWS100AF (STD Model:MOLEX connector,/J Type: JST connector)

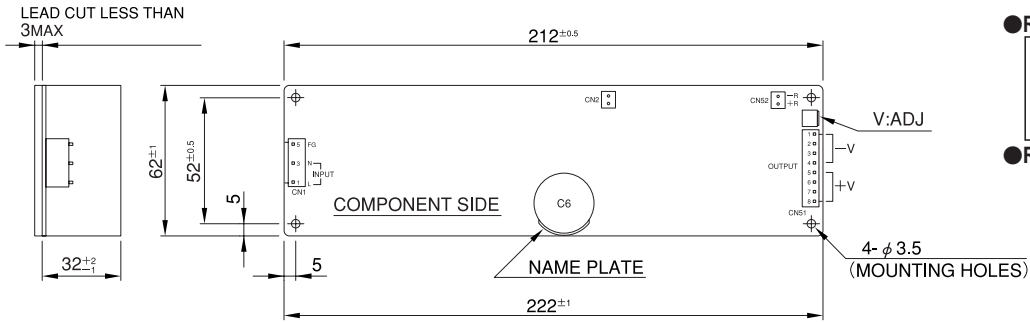

(Unit: mm)

## ■ ZWS100AF (/JA Type : With-cover Type)

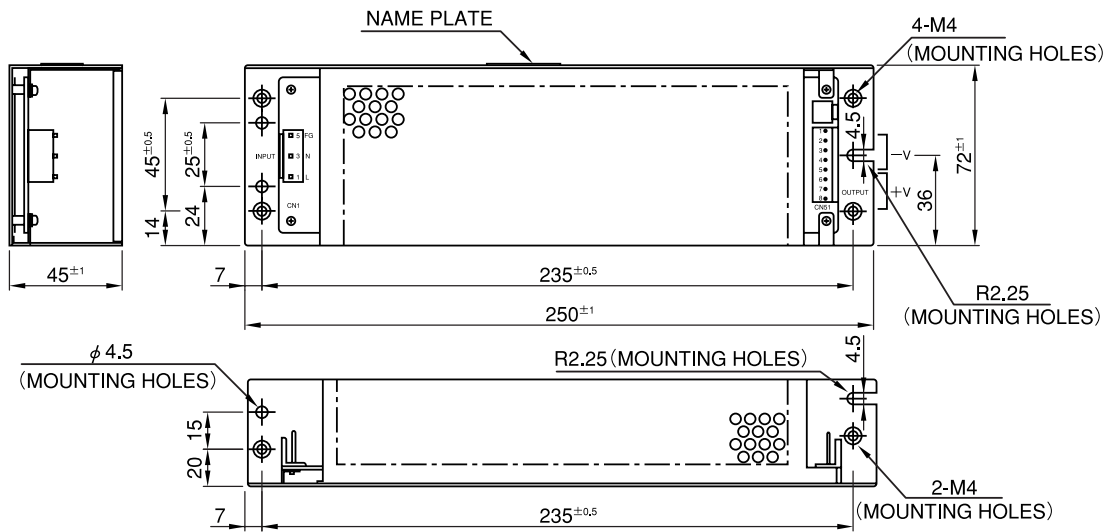

## ■ ZWS150AF (STD Model:MOLEX connector,/J Type: JST connector)

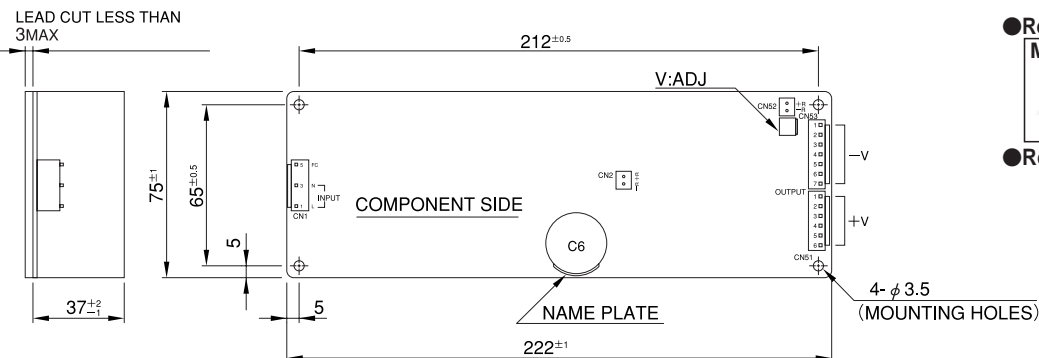

(Unit: mm)

## ■ ZWS150AF (/JA Type : With-cover Type)

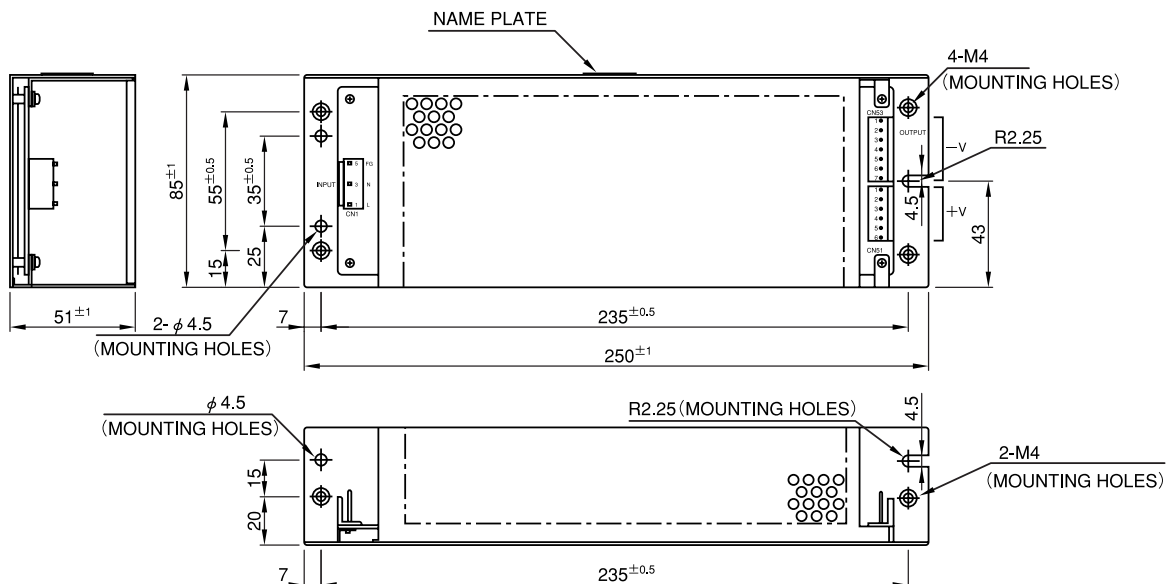

# ZWS-PF-SERIES

Single output 75W ~ 150W

**LAMBDA**  
DENSEI-LAMBDA

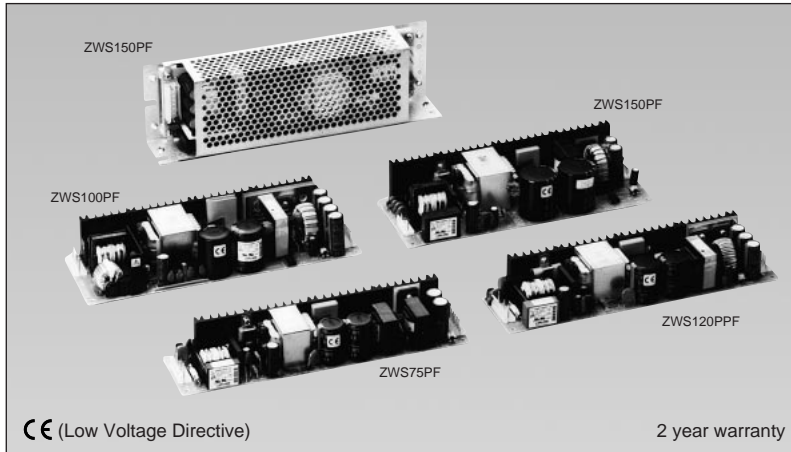

## Model name

**ZWS 100PF-5/**

Series Name

Output Wattage

Passive Filter contained

Output Voltage

Option

blank: Molex connector, PCB type (JST connector for 120PPF)  
A: Molex connector, with-cover type (JST connector for 120PPF)  
J: JST connector, PCB type  
JA: JST connector, with-cover type

## Features

- CE marking (Low Voltage Directive)
- Passive Filter contained, PFHC type
- Applicable to peak output wattage 120% (200% for ZWS120PPF)
- Low Cost!!
- Equipped with output variable voltage

CE (Low Voltage Directive)

2 year warranty

## Specifications

1. Input voltage range	85~132VAC/170~265VAC (47~63Hz)auto-selectable	
2. Output Voltage range	± 10%	
3. Cooling	Convection cooling	
4. Operating ambient temperature (Standard mounting)	ZWS100PF	-10°C~+50°C:100%,+60°C:60%
	ZWS120PPF	-10°C~+50°C:100%,+60°C:70%
	ZWS150PF	Convection cooling -10°C~+30°C:100%,+40°C:80%,+60°C:50% Forced air cooling -10°C~+50°C:100%,+60°C:70% (0.7m/S)
5. Withstand voltage	Input-output : 3kVAC (20mA) , Input-chassis : 2kVAC (20mA) , Output-chassis : 500VAC (100mA) for 1 min	
6. Safety standard	Approved by UL1950 , CSA950(C-UL) , EN60950(TUV)	
7. CE marking	Conforms to low voltage directive	
8. EMI	Meets to EN55011-B,EN55022-B,FCC-B,VCCI-B	
9. Immunity	Meets to EN50082-2(EN61000-4-2,-3,-4,-5,-6)	
10. PFHC	Meets to EN61000-3-2 ZWS75PF,ZWS100PF(Input power: over 50W) ZWS120PPF,ZWS150PF(Input power: over75W)	
11. Functions	Over voltage protection,Over current protection	

## Product lineup

Note 1

Model name		Nominal output voltage	Max. output current	Max. peak output current	Max. output power	UL	CSA	EN
ZWS75PF	ZWS75PF-3	3.3V	15A	18A	49.5W	○	○	○
	ZWS75PF-5	5V	15A	18A	75W	○	○	○
	ZWS75PF-12	12V	6.3A	7.5A	76W	○	○	○
	ZWS75PF-15	15V	5A	6A	75W	○	○	○
	ZWS75PF-24	24V	3.2A	3.8A	76.8W	○	○	○
	ZWS75PF-36	36V	2.1A	2.5A	75.6W	○	○	○
ZWS100PF	ZWS75PF-48	48V	1.6A	1.9A	76.8W	○	○	○
	ZWS100PF-3	3.3V	20A	24A	66W	○	○	○
	ZWS100PF-5	5V	20A	24A	100W	○	○	○
	ZWS100PF-12	12V	8.5A	10A	102W	○	○	○
	ZWS100PF-15	15V	6.7A	8A	100.5W	○	○	○
	ZWS100PF-24	24V	4.3A	5A	103.2W	○	○	○
ZWS120PPF	ZWS100PF-36	36V	2.8A	3.4A	100.8W	○	○	○
	ZWS100PF-48	48V	2.1A	2.5A	100.8W	○	○	○
	ZWS120PPF-24	24V	5A	10A	120W	○	○	○
ZWS150PF	ZWS120PPF-36	36V	3.4A	6.7A	122.4W	○	○	○
	ZWS150PF-3	3.3V	30A	36A	99W	○	○	○
	ZWS150PF-5	5V	30A	36A	150W	○	○	○
	ZWS150PF-12	12V	12.5A	15A	150W	○	○	○
	ZWS150PF-15	15V	10A	12A	150W	○	○	○
	ZWS150PF-24	24V	6.3A	7.5A	151.2W	○	○	○
	ZWS150PF-36	36V	4.2A	5A	151.2W	○	○	○
	ZWS150PF-48	48V	3.2A	3.8A	153.6W	○	○	○

Note1 : Duration at peak current 10 seconds max.(Duty : 0.35 max.)

●Based on the data under normal installation and without cover type. Needs output derating according to installation method or ambient temperature condition.

○ : Safety standard approved

# ZWS-PF-SERIES

## ZWS75PF (STD Model:MOLEX connector)

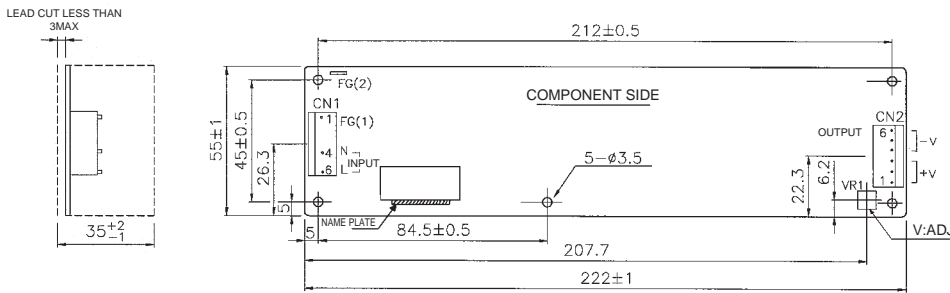

(Unit: mm)

## ZWS75PF (/J Type: JST connector)

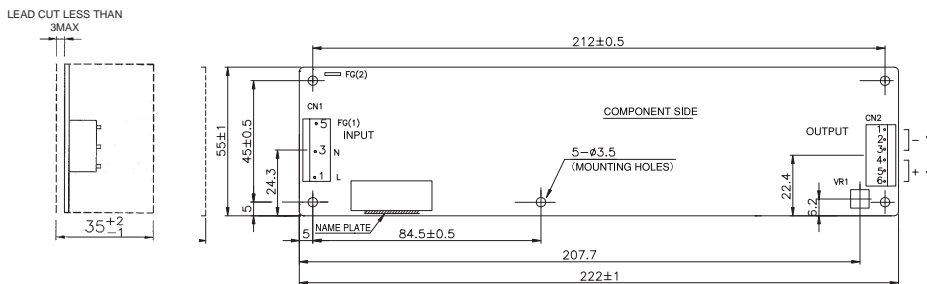

(Unit: mm)

## ZWS75PF (/JA Type : With-cover Type JST connector)

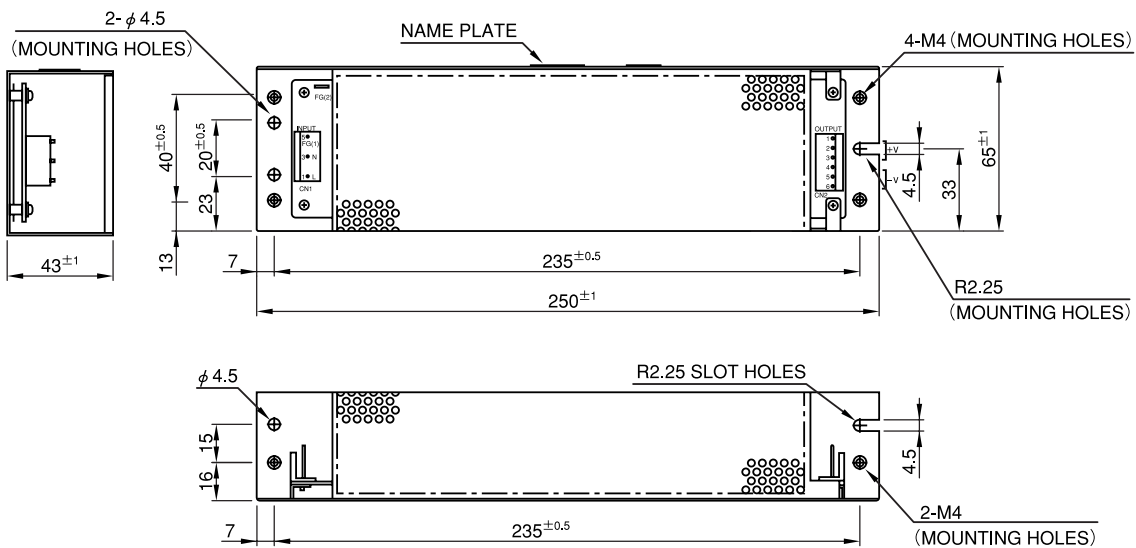

(Unit: mm)

## ZWS100PF (STD Model:MOLEX connector)

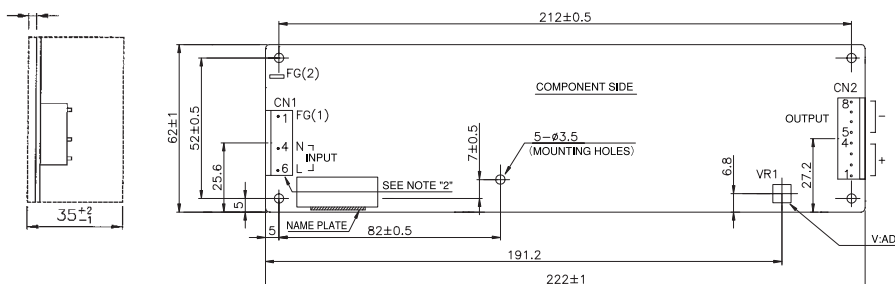

(Unit: mm)

PC Board Type Power Supply

# ZWS-PF-SERIES

## ZWS100PF (/J Type: JST connector)

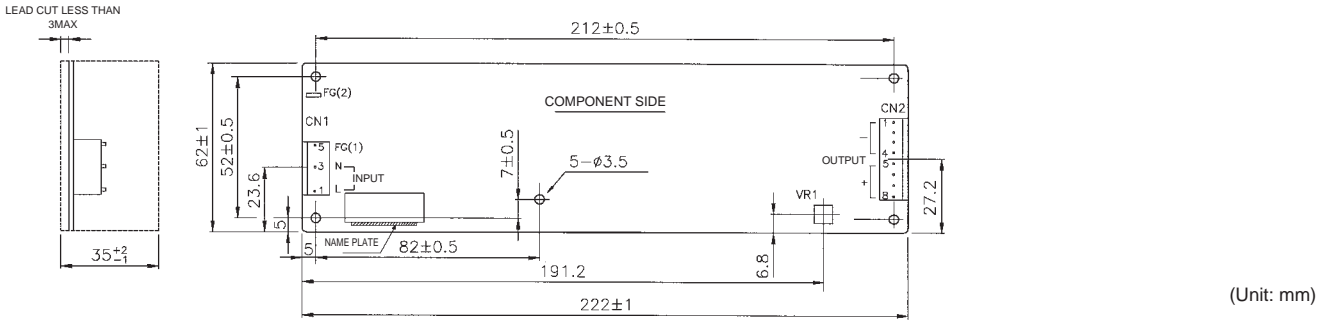

## ZWS100PF (/JA Type : With-cover Type JST connector)

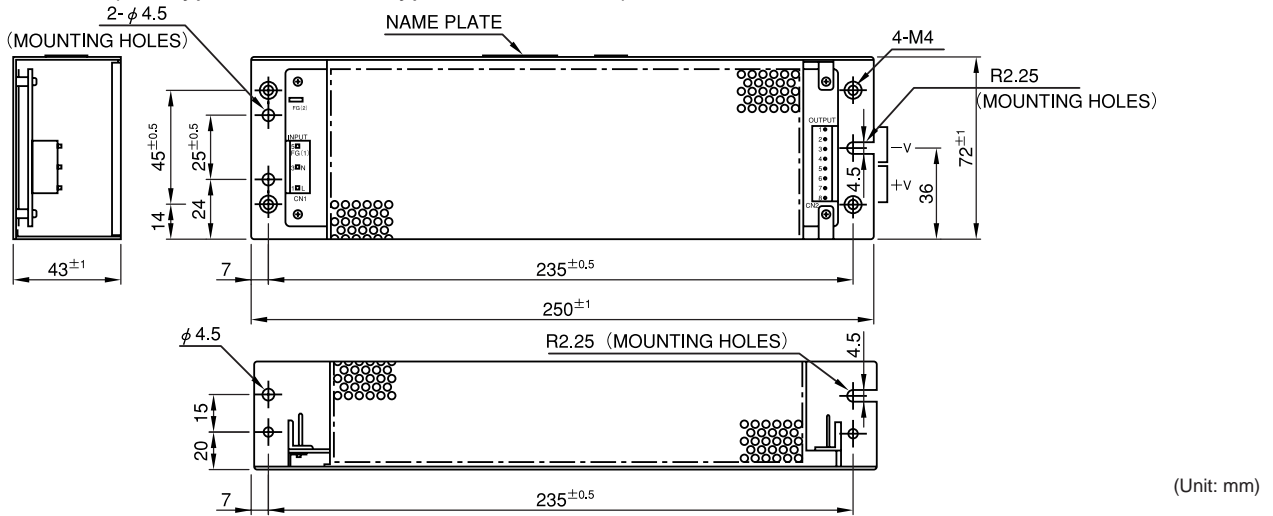

## ZWS120PPF (STD Model:JST connector)

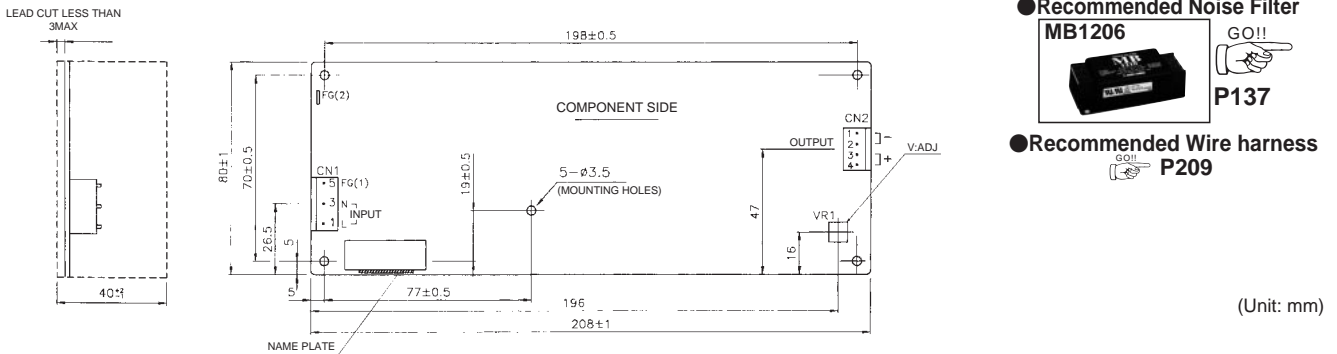

### Recommended Noise Filter



### Recommended Wire harness



## ZWS120PPF (/A Type : With-cover Type JST connector)

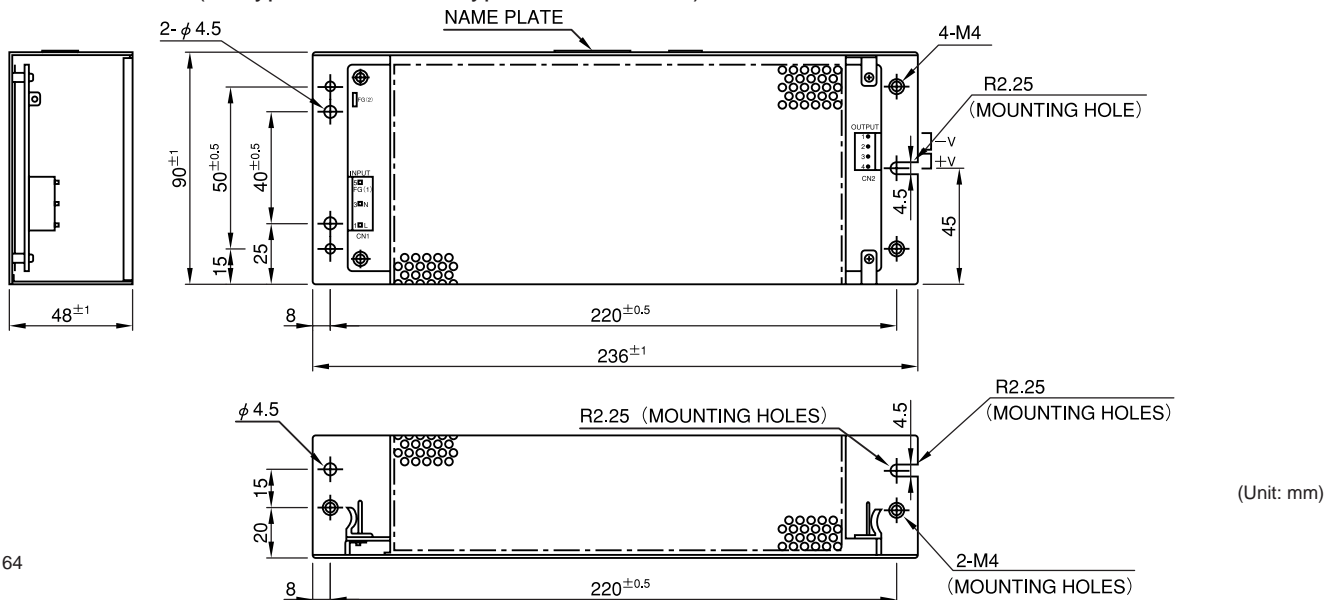

PC Board Type Power Supply

# ZWS-PF-SERIES

## ■ ZWS150PF (STD Model:MOLEX connector)

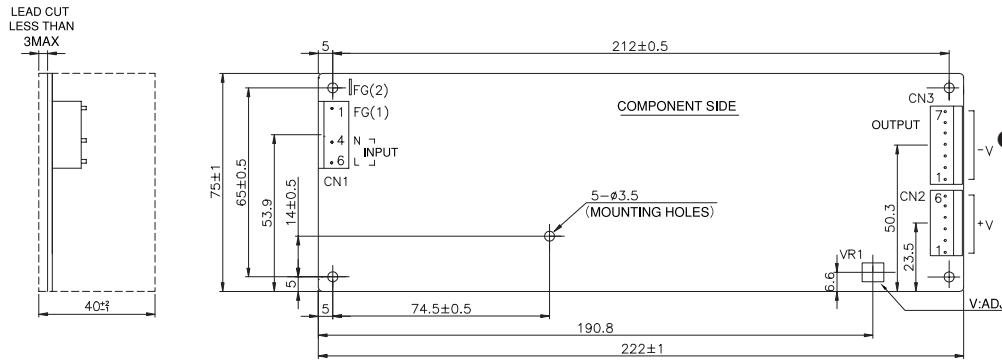

- Recommended Noise Filter  
**MB1206**  
GO!!  
**P137**
- Recommended Wire harness  
GO!!  
**P209**

PC Board Type Power Supply

(Unit: mm)

## ■ ZWS150PF (/J Type: JST connector)

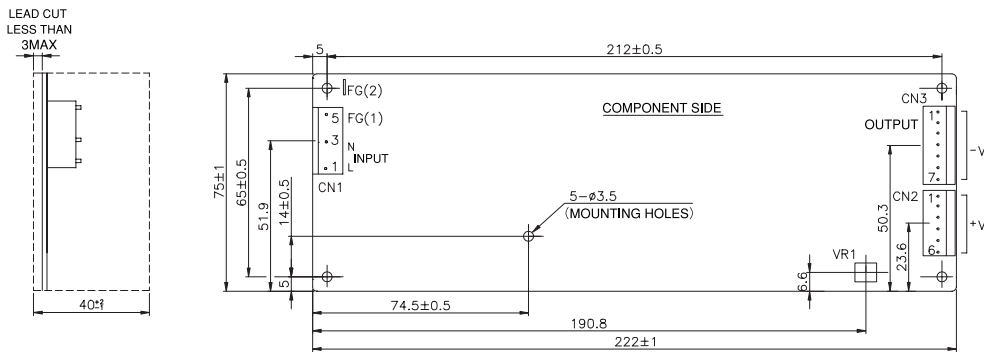

(Unit: mm)

## ■ ZWS150PF (/JA Type : With-cover Type JST connector)

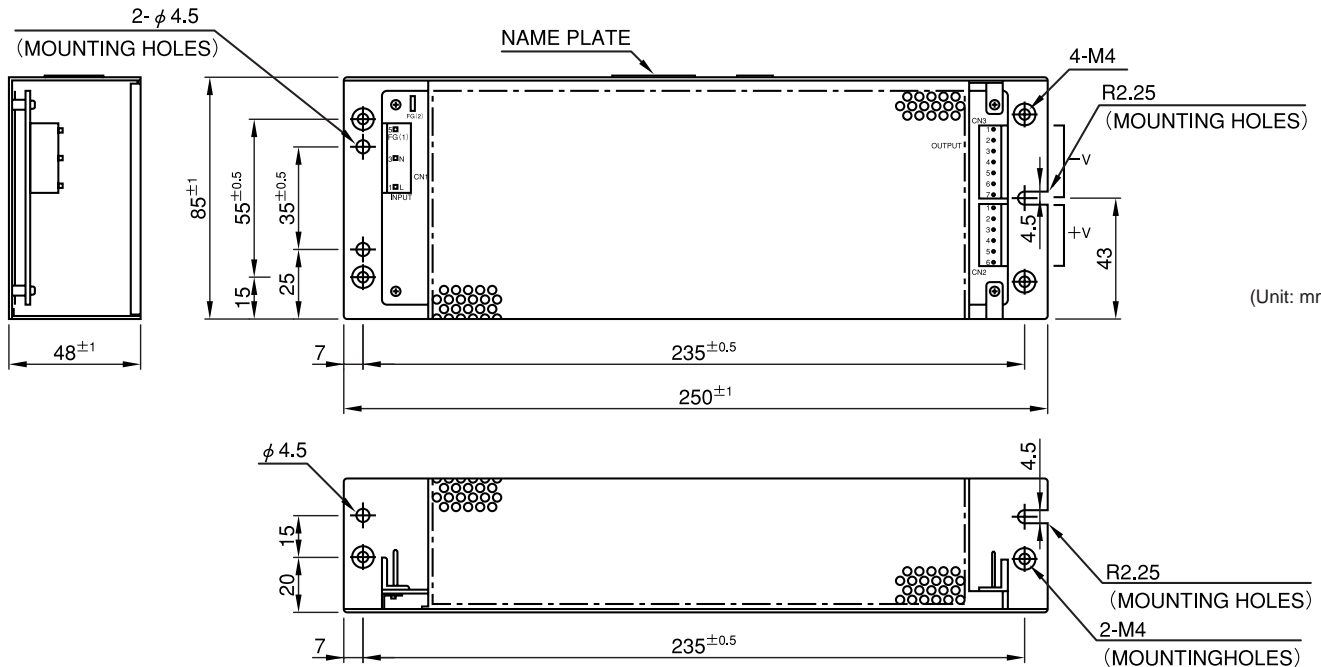

(Unit: mm)

(Unit: mm)

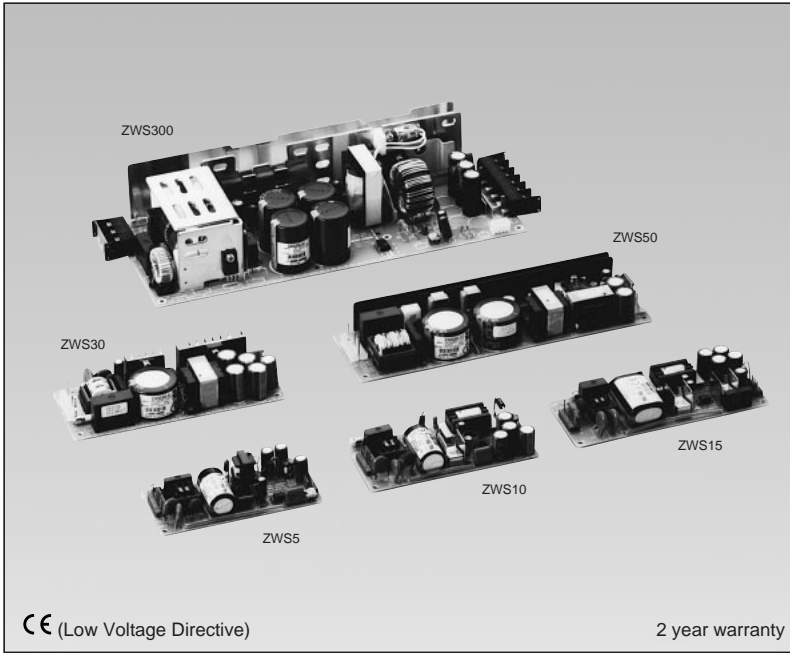

### Model name

**ZWS 10-5/□□**

Series Name      Output Wattage      Output Voltage      Option  
 blank: Molex connector, PCB type  
 A: Molex connector, with-cover type  
 J: JST connector, PCB type  
 JA: JST connector, with-cover type

**ZWS 300-5/□□**

Series Name      Output Wattage      Output Voltage      Option  
 R: With Remote ON/OFF control  
 T: Vertical terminal type  
 B: Input/Output connector terminal type  
 (Only for 12V-48V output type)

### Features

- CE marking (Low Voltage Directive)
- Wide input voltage range for 100V/200V, single output
- Low cost
- PCB type
- Applicable to various use; from office printer to air conditioning controller
- Applicable to peak current load

### Specifications

<b>1. Input voltage range</b>	ZWS5~50	85~265VAC (47~440Hz) , 110~330VDC universal input
	ZWS300	85~132/170~265VAC (47~440Hz) auto-selectable
<b>2. Output Voltage range</b>	± 10%	
<b>3. Cooling</b>	Convection cooling	
<b>4. Operating ambient temperature (Standard mounting)</b>	ZWS5~50	-10°C~+50°C:100%, +60°C:70%
	ZWS300	Convection cooling -10°C~+40°C:100%, +50°C:80%, +60°C:60% Forced air cooling -10°C~+50°C:100%, +60°C:75%, +70°C:50%
<b>5. Withstand voltage</b>	Input-output : 3kVAC (20mA) , Input-chassis : 2kVAC (20mA) , Output-chassis : 500VAC (100mA) for 1 min	
<b>6. Safety standard</b>	Approved by UL1950 , CSA950(C-UL) , EN60950(TUV)	
<b>7. CE marking</b>	Conforms to low voltage directive	
<b>8. EMI</b>	Meets to EN55011-B, EN55022-B, FCC-B, VCCI-B	
<b>9. Immunity</b>	Meets to EN50082-2(EN61000-4-2,-3,-4,-5,-6)	
<b>10. Functions</b>	Over voltage protection, Over current protection	

### Product lineup

Note 1

Model name	Nominal output voltage	Max. output current	Max. peak output current	Max. output power	UL	CSA	EN	
ZWS5	ZWS5-3	3.3V	1.0A	1.2A	3.3W	○	○	○
	ZWS5-5	5V	1.0A	1.2A	5W	○	○	○
	ZWS5-12	12V	0.42A	0.51A	5.04W	○	○	○
	ZWS5-15	15V	0.34A	0.41A	5.1W	○	○	○
	ZWS5-24	24V	0.22A	0.27A	5.28W	○	○	○
ZWS10	ZWS10-3	3.3V	2.0A	2.4A	6.6W	○	○	○
	ZWS10-5	5V	2.0A	2.4A	10W	○	○	○
	ZWS10-12	12V	0.85A	1.02A	10.2W	○	○	○
	ZWS10-15	15V	0.7A	0.84A	10.5W	○	○	○
ZWS15	ZWS10-24	24V	0.45A	0.54A	10.8W	○	○	○
	ZWS15-3	3.3V	3.0A	3.6A	9.9W	○	○	○
	ZWS15-5	5V	3.0A	3.6A	15W	○	○	○
	ZWS15-12	12V	1.25A	1.5A	15W	○	○	○
	ZWS15-15	15V	1.0A	1.2A	15W	○	○	○
ZWS15-24	24V	0.65A	0.78A	15.6W	○	○	○	

Note 1

Model name	Nominal output voltage	Max. output current	Max. peak output current	Max. output power	UL	CSA	EN	
ZWS30	ZWS30-3	3.3V	6.0A	7.2A	19.8W	○	○	○
	ZWS30-5	5V	6.0A	7.2A	30W	○	○	○
	ZWS30-12	12V	2.5A	3.0A	30W	○	○	○
	ZWS30-15	15V	2.0A	2.4A	30W	○	○	○
	ZWS30-24	24V	1.3A	1.56A	31.2W	○	○	○
	ZWS30-36	36V	0.9A	1.08A	32.4W	○	○	○
ZWS50	ZWS30-48	48V	0.7A	0.84A	33.6W	○	○	○
	ZWS50-3	3.3V	10A	12A	33W	○	○	○
	ZWS50-5	5V	10A	12A	50W	○	○	○
	ZWS50-12	12V	4.3A	5.16A	51.6W	○	○	○
	ZWS50-15	15V	3.5A	4.2A	52.5W	○	○	○
	ZWS50-24	24V	2.1A	2.52A	50.4W	○	○	○
	ZWS50-36	36V	1.4A	1.68A	50.4W	○	○	○
	ZWS50-48	48V	1.1A	1.32A	52.8W	○	○	○

○ : Safety standard approved

Note 1: Duration at peak current: 10 seconds max., Duty: Below 35%.

- Standard model: Molex connector
- "J" model is available with J.S.T connector.

ZWS300 Series	Convection cooling				Forced air cooling			Safety standard		
	Model name	Nominal output voltage	Maximum output current	Maximum output power	Max. peak output power	Nominal output voltage	Maximum output current	Maximum output power	UL	CSA
ZWS300-3	3.3V	40A	132W	198W	3.3V	60A	198W	○	○	○
ZWS300-5	5V	40A	200W	300W	5V	60A	300W	○	○	○
ZWS300-12	12V	17A	204W	324W	12V	27A	324W	○	○	○
ZWS300-15	15V	14A	210W	330W	15V	22A	330W	○	○	○
ZWS300-24	24V	9A	216W	336W	24V	14A	336W	○	○	○
ZWS300-48	48V	4.2A	201.6W	302.4W	48V	6.3A	302.4W	○	○	○

Note : Duration under peak application is limited less than 30 seconds.  
 (Average output current under those condition should not exceed maximum output power.)

- Request customer specification for further details of specifications, outline, characteristics, etc. Read the instruction manual before usage.
- Contact us about delivery before ordering.



# ZWS-SERIES

## ■ ZWS5 (MOLEX connector)

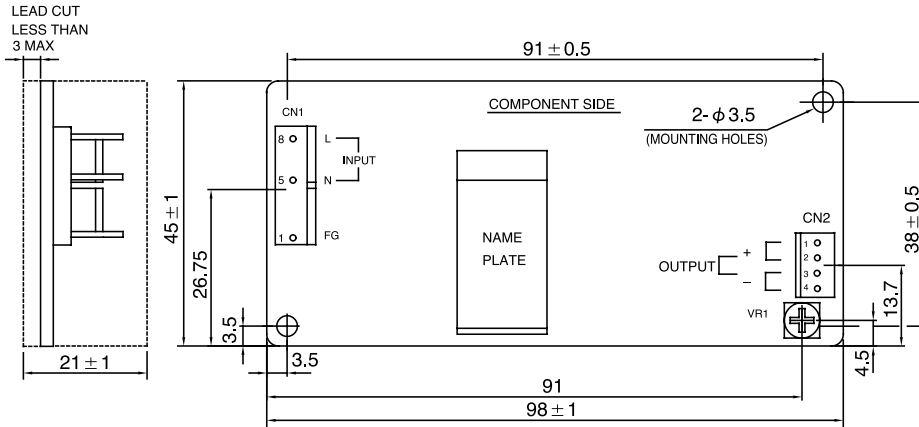

● Recommended Noise Filter

MAW-12R5-22



P134

● Recommended Wire harness

P209

(Unit: mm)

PC Board Type Power Supply

## ■ ZWS5 (J Type : JST connector)

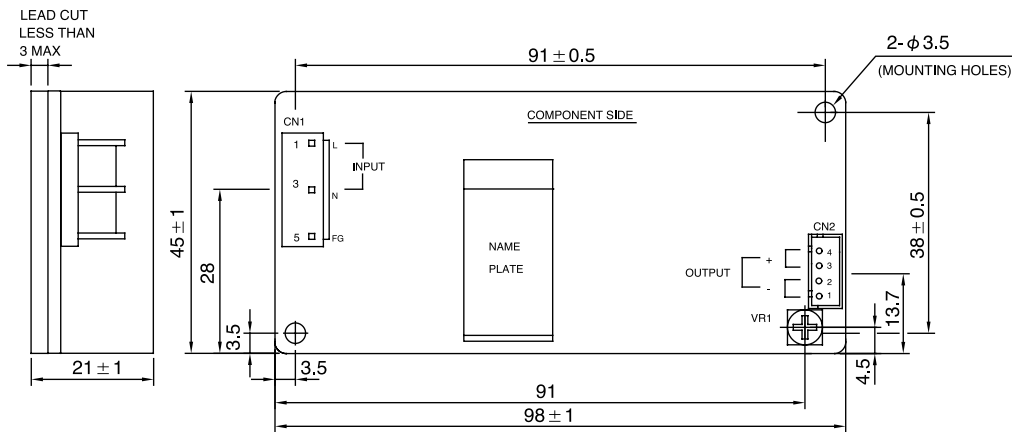

(Unit: mm)

## ■ ZWS5 (/JA Type : With-cover Type)

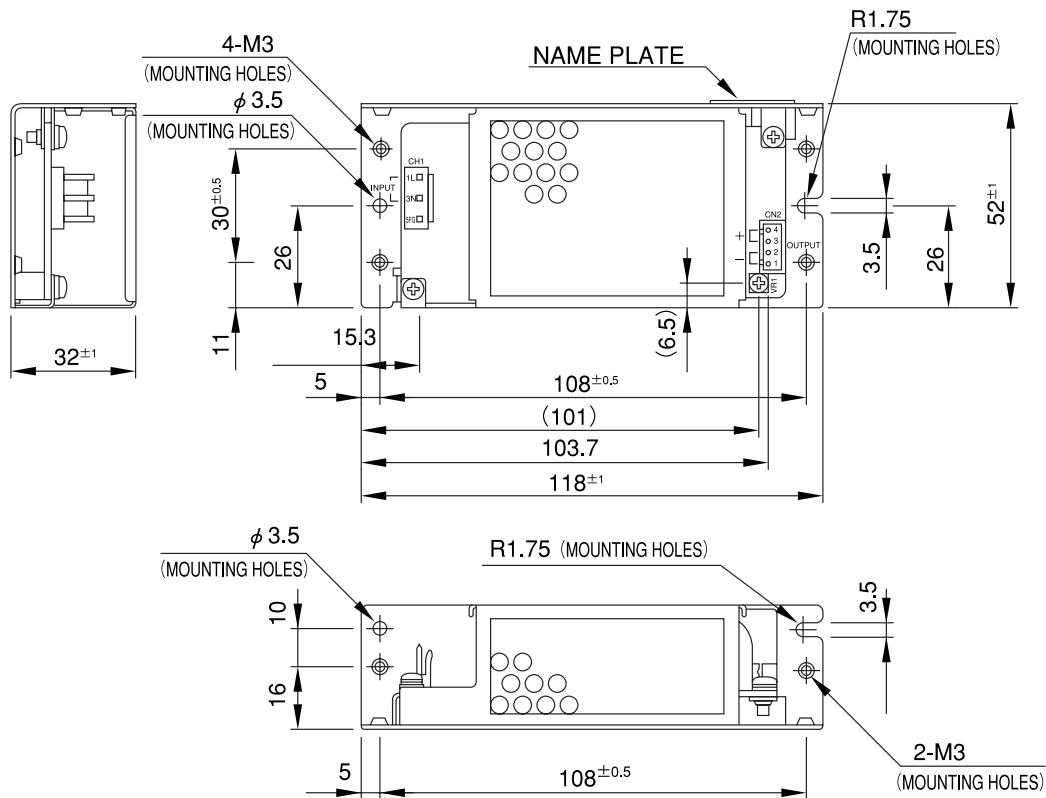

(Unit: mm)

## ■ ZWS10 (MOLEX connector)

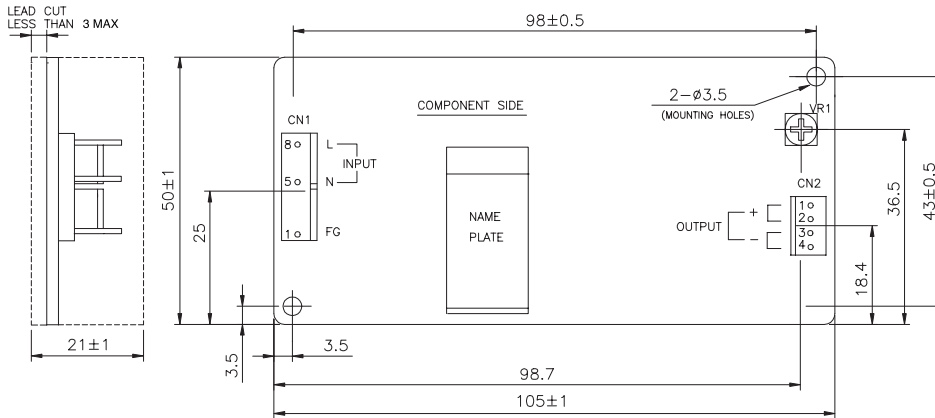

● Recommended Noise Filter

MAW-12R5-22



P134

● Recommended Wire harness

P209



(Unit: mm)

## ■ ZWS10 (J Type : JST connector)

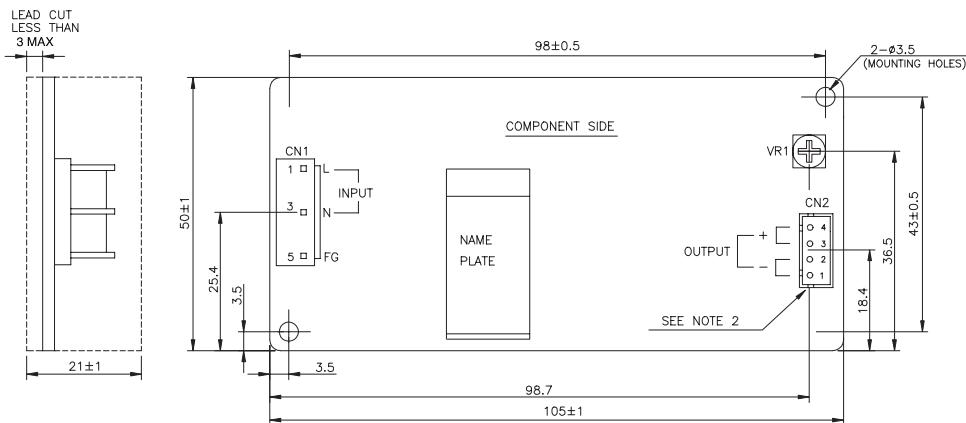

(Unit: mm)

## ■ ZWS10 (/JA Type : With-cover Type)

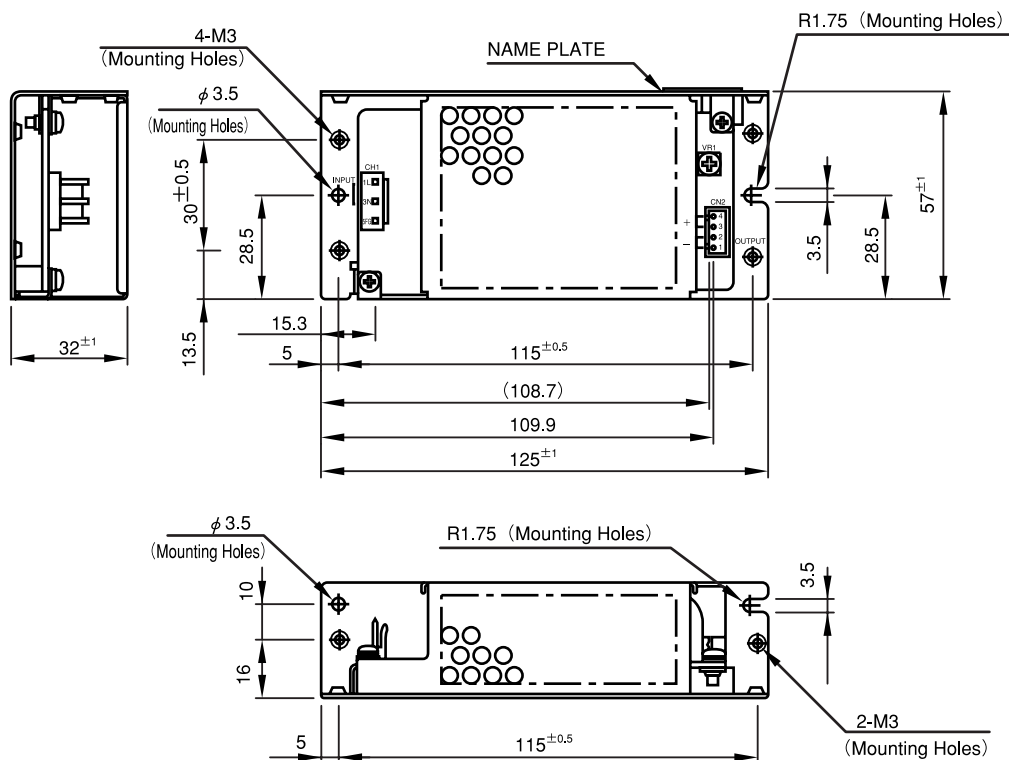

# ZWS-SERIES

## ■ ZWS15 (MOLEX connector)

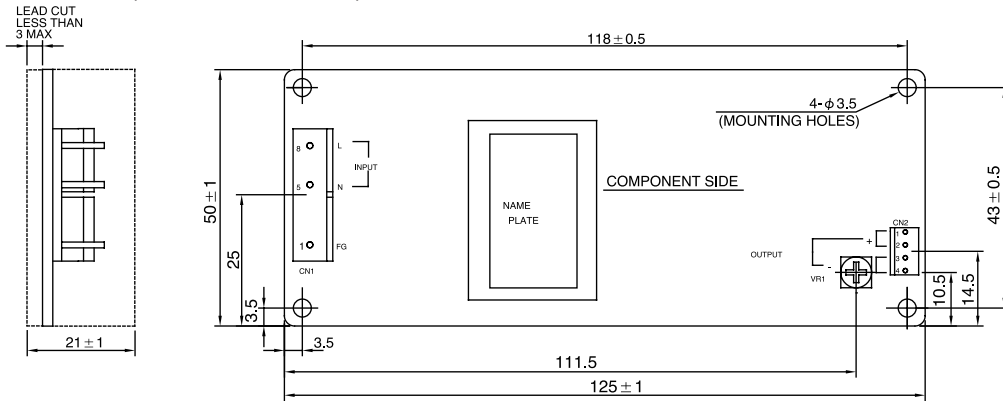

● Recommended Noise Filter

MAW-1201-22



P134

● Recommended Wire harness

P209

(Unit: mm)

## ■ ZWS15 (J Type : JST connector)

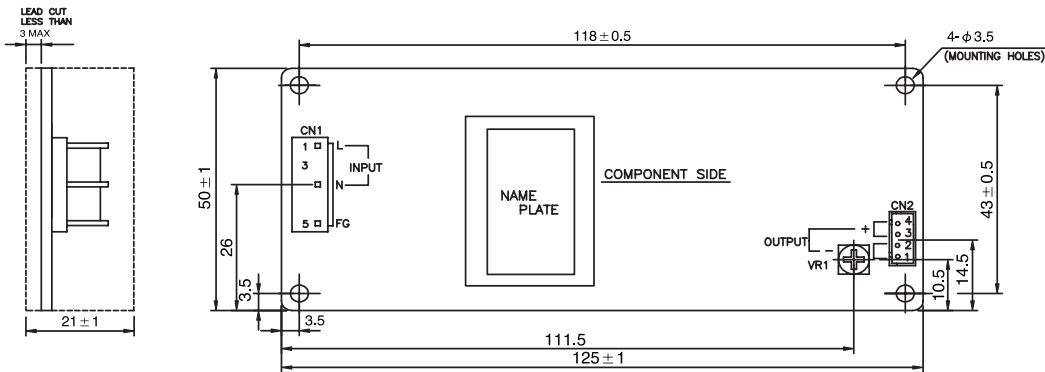

(Unit: mm)

## ■ ZWS15 (/JA Type : With-cover Type)

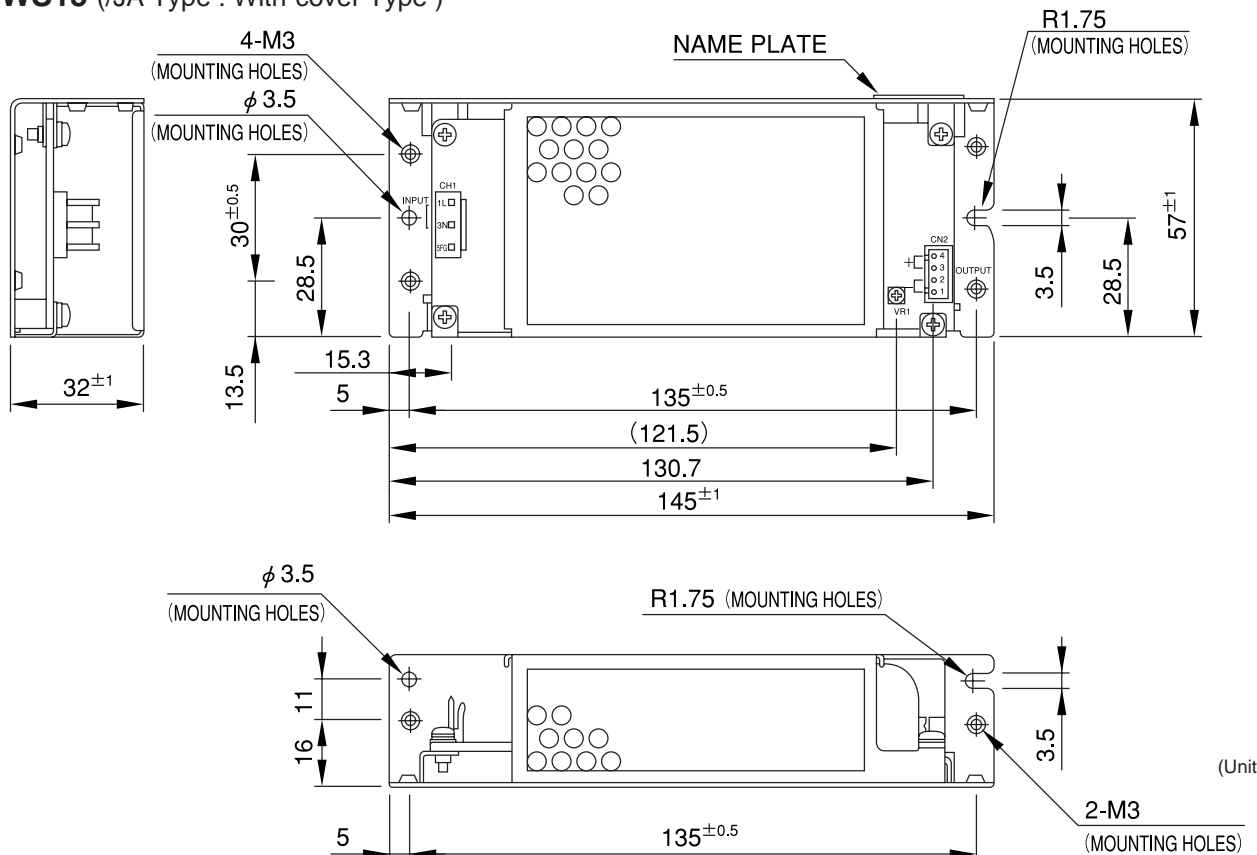

(Unit: mm)

## ■ ZWS30 (MOLEX connector)

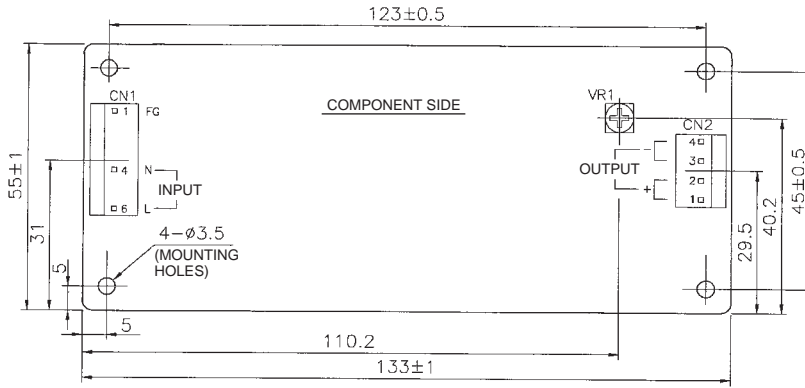
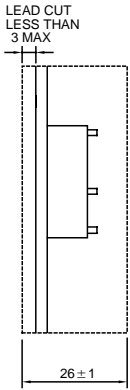

● Recommended Noise Filter

**MAW-1202-22**



**P134**

● Recommended Wire harness

**P209**



(Unit: mm)

## ■ ZWS30 (J Type : JST connector)

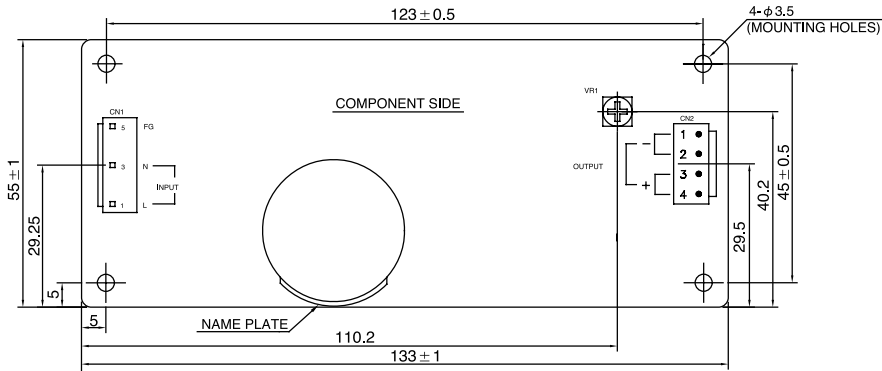
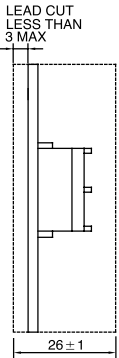

(Unit: mm)

## ■ ZWS30 (/JA Type : With-cover Type)

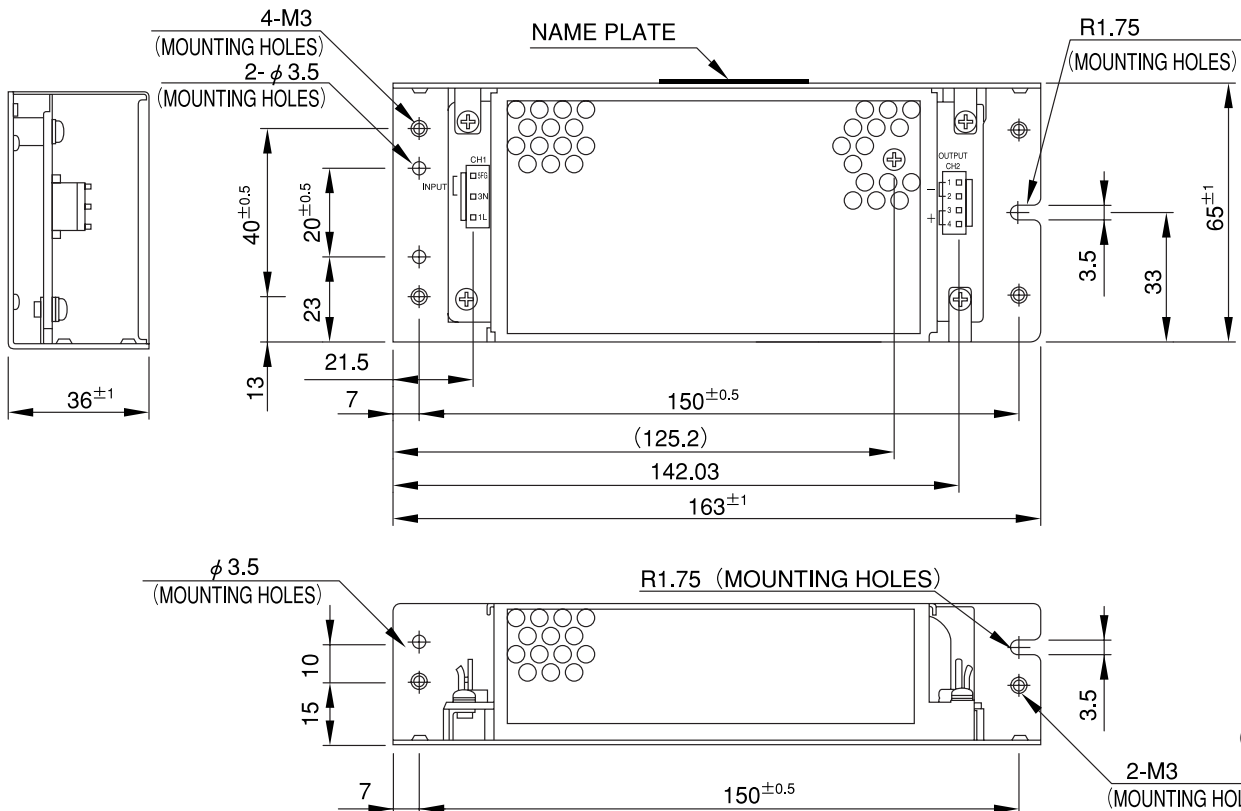

(Unit: mm)

# ZWS-SERIES

## ■ ZWS50 (MOLEX connector)

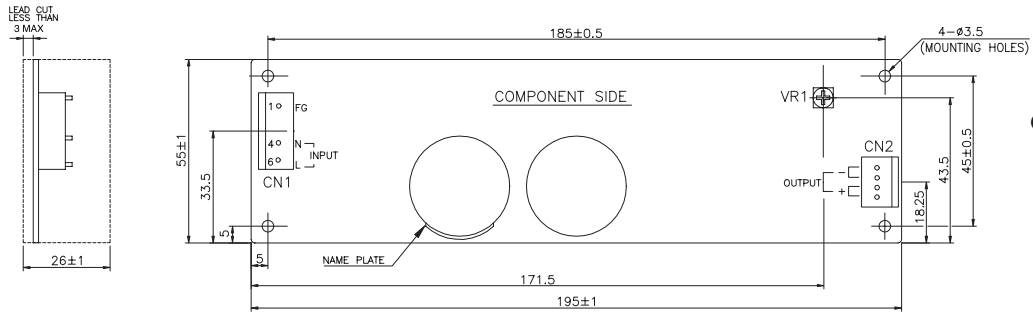

● Recommended Noise Filter

MAW-1202-22



P134

● Recommended Wire harness

P209

(Unit: mm)

## ■ ZWS50 (J Type : JST connector)

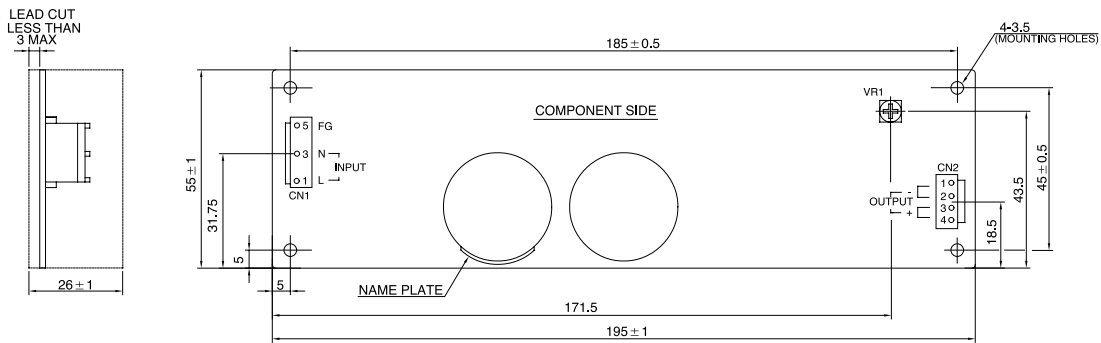

(Unit: mm)

## ■ ZWS50 (/JA Type : With-cover Type)

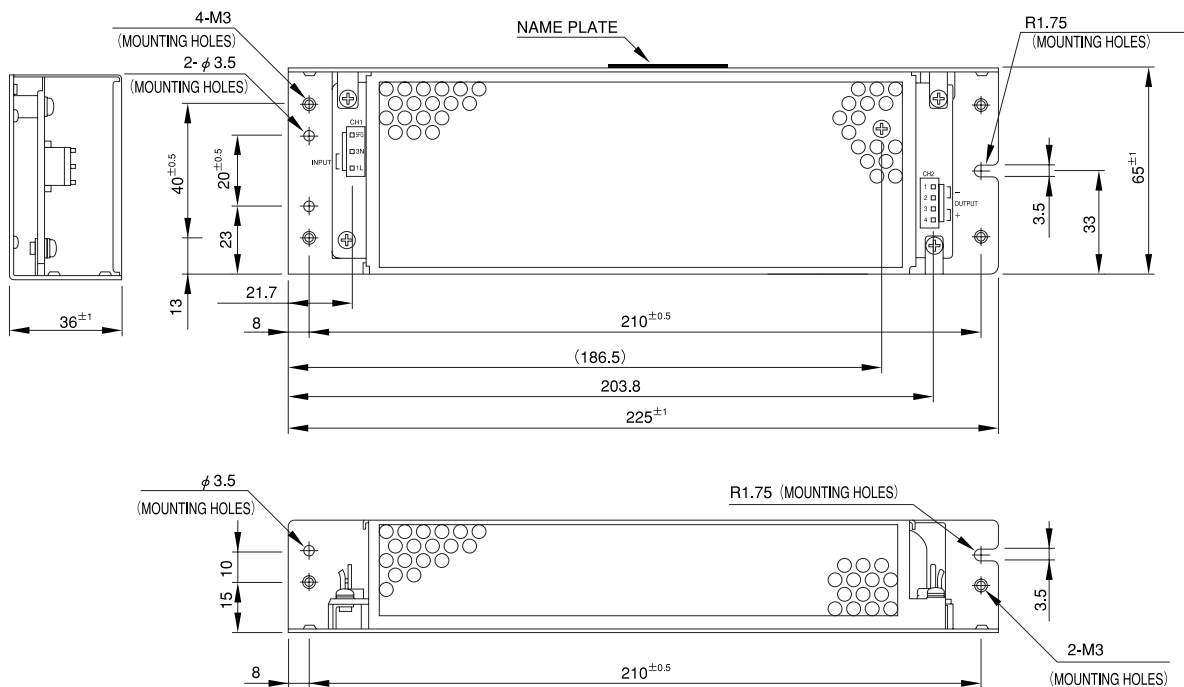

(Unit: mm)

## ZWS300-□ (Horizontal terminal type)

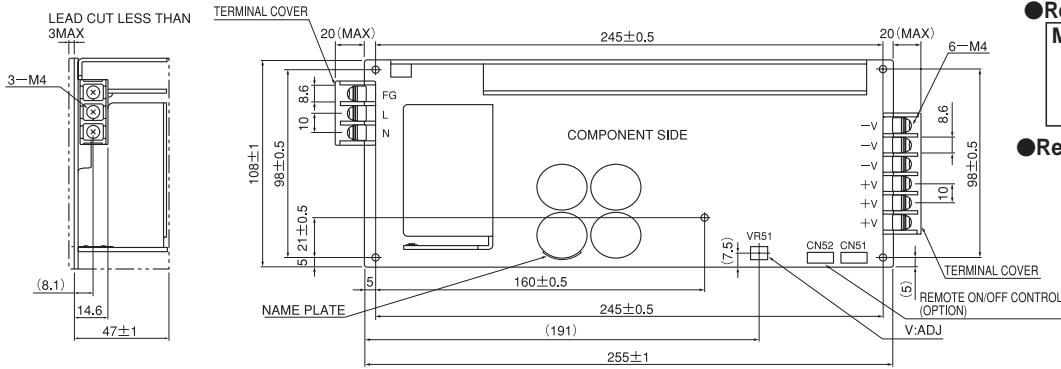

● Recommended Noise Filter



GO!!  
**P137**

● Recommended Wire harness

GO!!  
**P209**

(Unit: mm)

## ZWS300-□/T (Vertical terminal type)

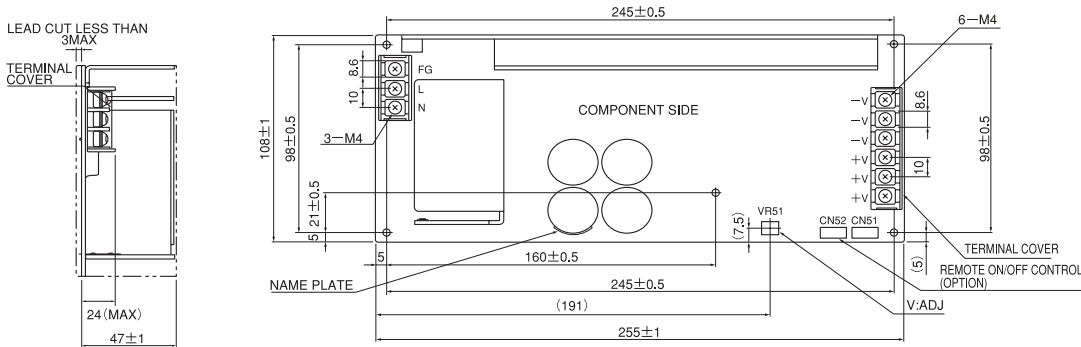

(Unit: mm)

## ZWS300-□/B (Input/Output connector terminal type {Only for 12V~48V output type})

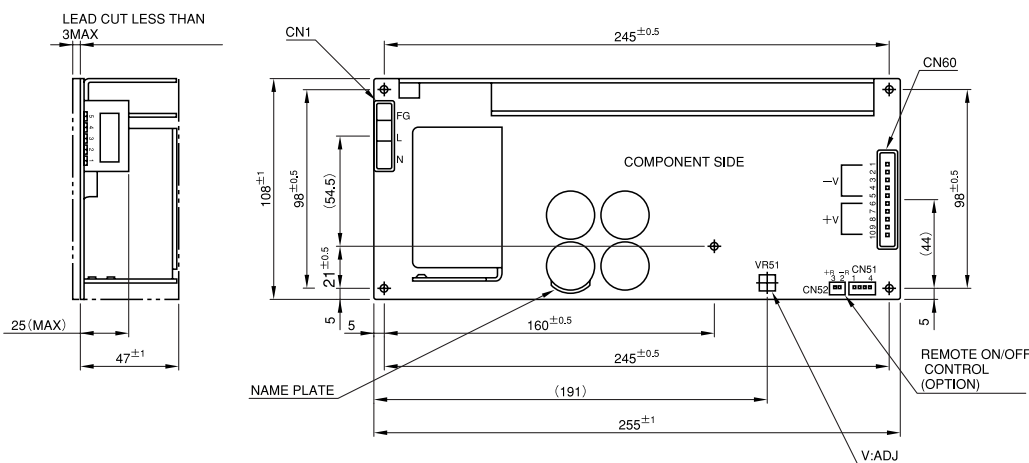

(Unit: mm)

# ZWS-PAF-SERIES

Single output 150W , 240W

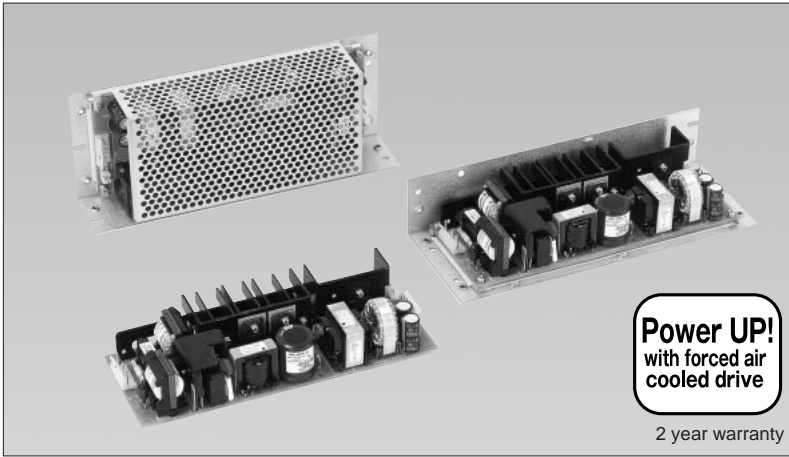

## Model name

**ZWS 150PAF-24/** 



Series Name      Output Wattage      Rated Output Voltage      Option

## Features

- Harmonic correction (PFHC).
- Meets input requirement of the mechatronics industry: Applicable to DC24V pulse load.
- Ultra compact and high power: Capable of 200% of average wattage at the peak point.
- Wide input voltage range: Changeable with AC85 - 265V continuous input.
- Meets the harmonic correction requirements: Built-in active filter circuit included.
- Low leak current: Convenient for use in conjunction with power supplies together.
- Enriched options: Input/Output terminals and the case are selectable.
- 2 year warranty.

PC Board Type Power Supply

## Specifications

<b>1. Input voltage range</b>	AC85 ~ 265V (47 - 63Hz.) or DC120~370V		
<b>2. Max. output wattage (average)</b>	Convection Cooling (*1)	ZWS150PAF-24: 24V 6.3A/151.2W, ZWS150PAF-36: 36V 4.2A/151.2W, ZWS150PAF-48: 48V 3.1A/148.8W	ZWS240PAF-24: 24V 10A/240W, ZWS240PAF-36: 36V 6.7A/241.2W, ZWS240PAF-48: 48V 5A/240W
	Forced air cooling (*1)(*2)	ZWS150PAF-24: 24V 8.4A/201.6W, ZWS150PAF-36: 36V 5.6A/201.6W, ZWS150PAF-48: 48V 4.3A/206.4W	ZWS240PAF-24: 24V 12.5A/300W, ZWS240PAF-36: 36V 8.4A/302.4W, ZWS240PAF-48: 48V 6.3A/302.4W
<b>3. Rated output wattage (peak)</b>	ZWS150PAF-24: 24V 12A/288W, ZWS150PAF-36: 36V 8A/288W, ZWS150PAF-48: 48V 6A/288W ZWS240PAF-24: 24V 20A/480W, ZWS240PAF-36: 36V 13.3A/478.8W, ZWS240PAF-48: 48V 10A/480W		
<b>4. Leakage current</b>	0.5mA Max, 0.1mA(Typ) at 100VAC / 0.16mA(Typ) at 230VAC		
<b>5. Cooling</b>	Convection cooling		
<b>6. Operating ambient temperature</b>	- 10 ~ +60 °C (with temperature derating)		
<b>7. Harmonic correction requirements</b>	Conforms to EN61000-3-2 (Built-in active filter included)		
<b>8. Immunity requirements</b>	Conforms to EN61000-4-2,-3,-4,-5,-6,-8,-11		
<b>9. EMI noise requirements</b>	Conforms to EN55022-B, VCCI-B, FCC-B		
<b>10. Safety standard</b>	Approved by UL60950, CSA950,  , EN60950  , CE marking applied		
<b>11. Dimensions (W x H x D)</b>	ZWS150PAF: 80mm x 40mm x 208mm (STD, /J type)    ZWS240PAF: 95mm x 45mm x 222mm (STD, /J type)		

Note \*1: Needs output derating according to the mounting directions or ambient temperature at convection air cooling.

\*2: For forced air cooling, air current of 1.5m/s or higher applied to the circuit board is required.

\*3: Please use with peak current operation of less than 10 seconds.

## Product lineup

Model	Input and output style				Case style		UL	CSA	EN
	Connector		Terminal block		L-angle	Cover			
	Molex	JST	Horizontal	Vertical					
ZWS150PAF-24	○						○	○	○
ZWS150PAF-24/L	○				○		○	○	○
ZWS150PAF-24/A	○					○	○	○	○
ZWS150PAF-24/J		○					○	○	○
ZWS150PAF-24/JL		○			○		○	○	○
ZWS150PAF-24/JA		○				○	○	○	○
ZWS150PAF-24/T			○				○	○	○
ZWS150PAF-24/TL			○		○		○	○	○
ZWS150PAF-24/TA			○			○	○	○	○
ZWS150PAF-24/S				○			○	○	○
ZWS150PAF-24/SL				○	○		○	○	○
ZWS150PAF-24/SA				○		○	○	○	○
ZWS150PAF-36	○						○	○	○
ZWS150PAF-36/L	○				○		○	○	○
ZWS150PAF-36/A	○					○	○	○	○
ZWS150PAF-36/J		○					○	○	○
ZWS150PAF-36/JL		○			○		○	○	○
ZWS150PAF-36/JA		○				○	○	○	○
ZWS150PAF-36/T			○				○	○	○
ZWS150PAF-36/TL			○		○		○	○	○
ZWS150PAF-36/TA			○			○	○	○	○
ZWS150PAF-36/S				○			○	○	○
ZWS150PAF-36/SL				○	○		○	○	○
ZWS150PAF-36/SA				○		○	○	○	○
ZWS150PAF-48	○						○	○	○
ZWS150PAF-48/L	○				○		○	○	○
ZWS150PAF-48/A	○					○	○	○	○
ZWS150PAF-48/J		○					○	○	○
ZWS150PAF-48/JL		○			○		○	○	○
ZWS150PAF-48/JA		○				○	○	○	○
ZWS150PAF-48/T			○				○	○	○
ZWS150PAF-48/TL			○		○		○	○	○
ZWS150PAF-48/TA			○			○	○	○	○
ZWS150PAF-48/S				○			○	○	○
ZWS150PAF-48/SL				○	○		○	○	○
ZWS150PAF-48/SA				○		○	○	○	○

Model	Input and output style				Case style		UL	CSA	EN
	Connector		Terminal block		L-angle	Cover			
	Molex	JST	Horizontal	Vertical					
ZWS240PAF-24							○	○	○
ZWS240PAF-24/L					○		○	○	○
ZWS240PAF-24/A						○	○	○	○
ZWS240PAF-24/J		○					○	○	○
ZWS240PAF-24/JL		○			○		○	○	○
ZWS240PAF-24/JA		○				○	○	○	○
ZWS240PAF-24/T			○				○	○	○
ZWS240PAF-24/TL			○		○		○	○	○
ZWS240PAF-24/TA			○			○	○	○	○
ZWS240PAF-24/S				○			○	○	○
ZWS240PAF-24/SL				○	○		○	○	○
ZWS240PAF-24/SA				○		○	○	○	○
ZWS240PAF-36	○						○	○	○
ZWS240PAF-36/L	○				○		○	○	○
ZWS240PAF-36/A	○					○	○	○	○
ZWS240PAF-36/J		○					○	○	○
ZWS240PAF-36/JL		○			○		○	○	○
ZWS240PAF-36/JA		○				○	○	○	○
ZWS240PAF-36/T			○				○	○	○
ZWS240PAF-36/TL			○		○		○	○	○
ZWS240PAF-36/TA			○			○	○	○	○
ZWS240PAF-36/S				○			○	○	○
ZWS240PAF-36/SL				○	○		○	○	○
ZWS240PAF-36/SA				○		○	○	○	○
ZWS240PAF-48	○						○	○	○
ZWS240PAF-48/L	○				○		○	○	○
ZWS240PAF-48/A	○					○	○	○	○
ZWS240PAF-48/J		○					○	○	○
ZWS240PAF-48/JL		○			○		○	○	○
ZWS240PAF-48/JA		○				○	○	○	○
ZWS240PAF-48/T			○				○	○	○
ZWS240PAF-48/TL			○		○		○	○	○
ZWS240PAF-48/TA			○			○	○	○	○
ZWS240PAF-48/S				○			○	○	○
ZWS240PAF-48/SL				○	○		○	○	○
ZWS240PAF-48/SA				○		○	○	○	○

○ : Safety standard approved

# ZWS-PAF-SERIES

## ■ ZWS150PAF (MOLEX connector type), /J (JST connector type)

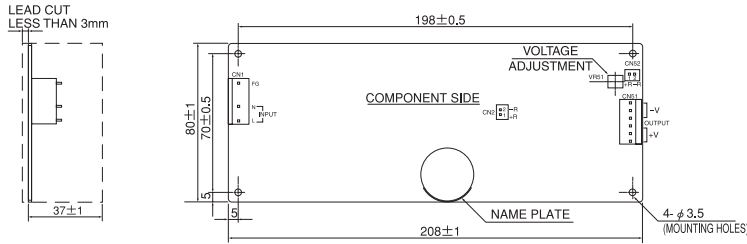

### ● Recommended Noise Filter

**MAW-1202-22**



GO!!

**P134**

### ● Recommended Wire harness

GO!!

**P209**

(Unit: mm)

## ■ ZWS150PAF/L (Molex connector, with L-angle type), /JL (JST connector, with L-angle type)

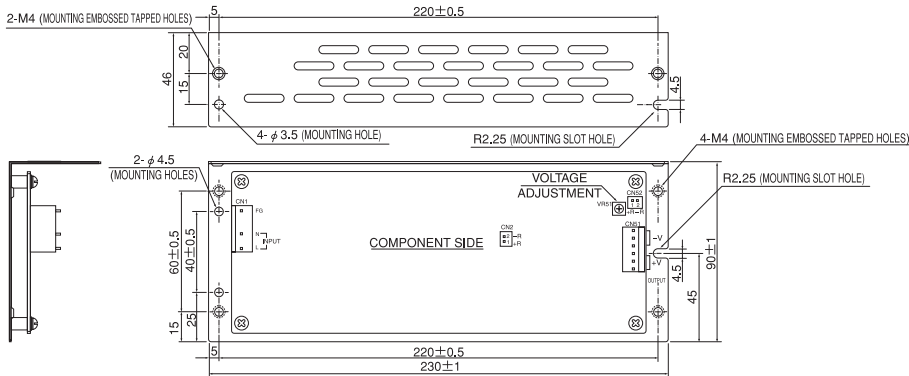

(Unit: mm)

## ■ ZWS150PAF/A (Molex connector, with Cover type), /JA (JST connector, with Cover type)

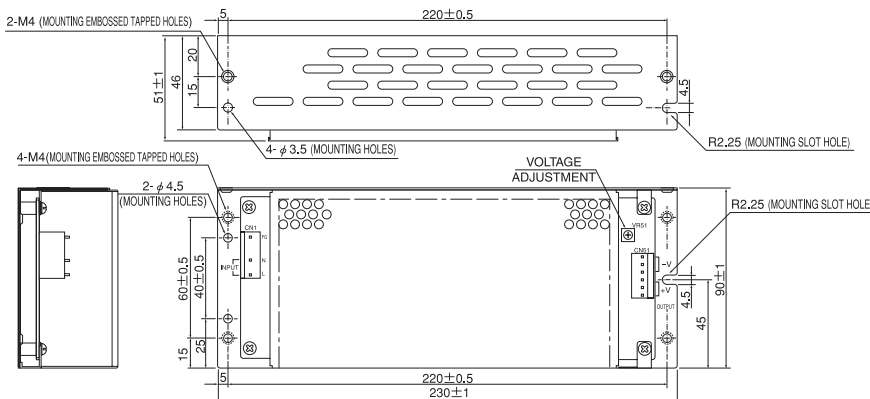

(Unit: mm)

## ■ ZWS150PAF/T (Vertical terminal type)

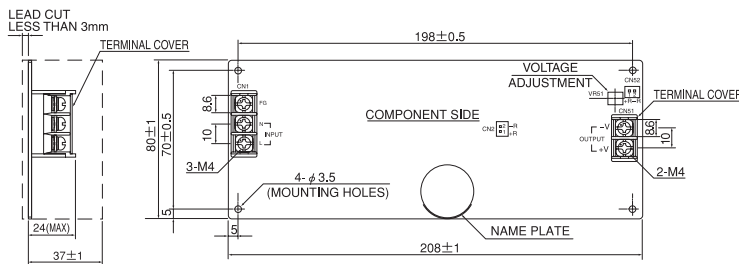

(Unit: mm)

## ■ ZWS150PAF/TL (Vertical terminal, with L-angle type)

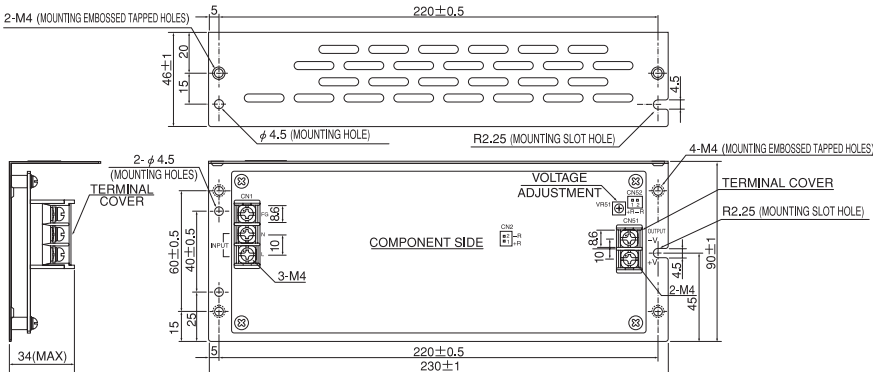

(Unit: mm)



# ZWS-PAF-SERIES

## ■ ZWS150PAF/TA (Vertical terminal, with Cover type)

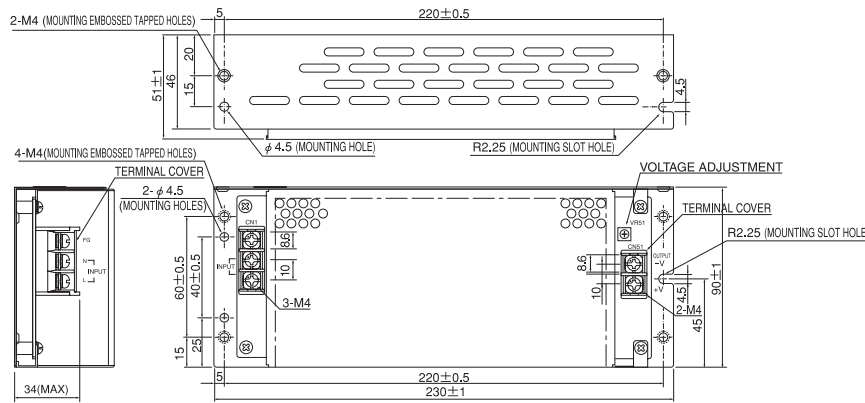

(Unit: mm)

## ■ ZWS150PAF/S (Horizontal terminal type)

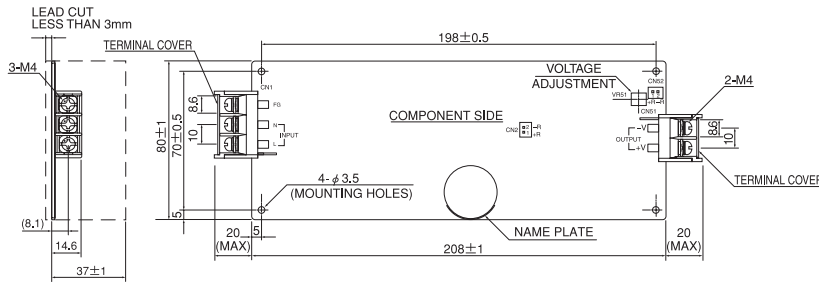

(Unit: mm)

## ■ ZWS150PAF/SL (Horizontal terminal, with L-angle type)

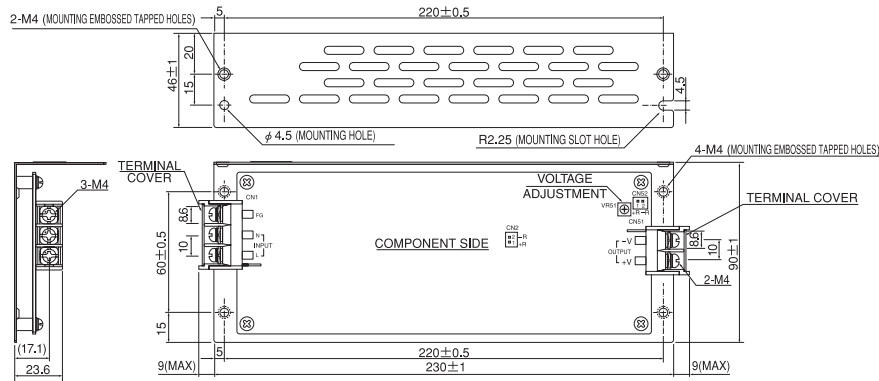

(Unit: mm)

## ■ ZWS150PAF/SA (Horizontal terminal, with Cover type)

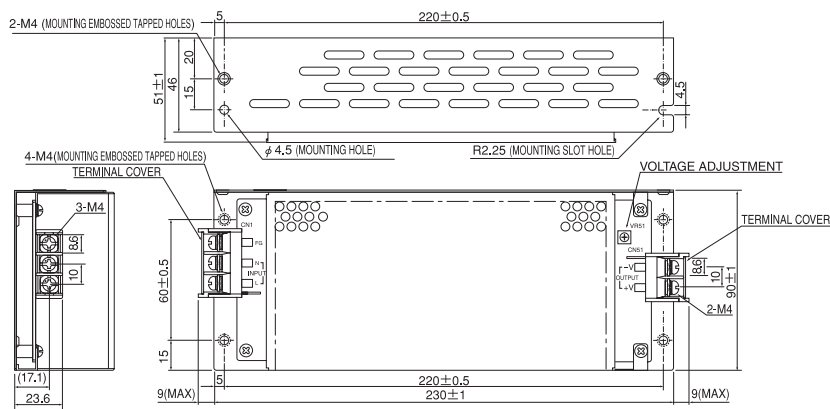

(Unit: mm)



# ZWS-PAF-SERIES

## ZWS240PAF/TA (Vertical terminal, with Cover type)

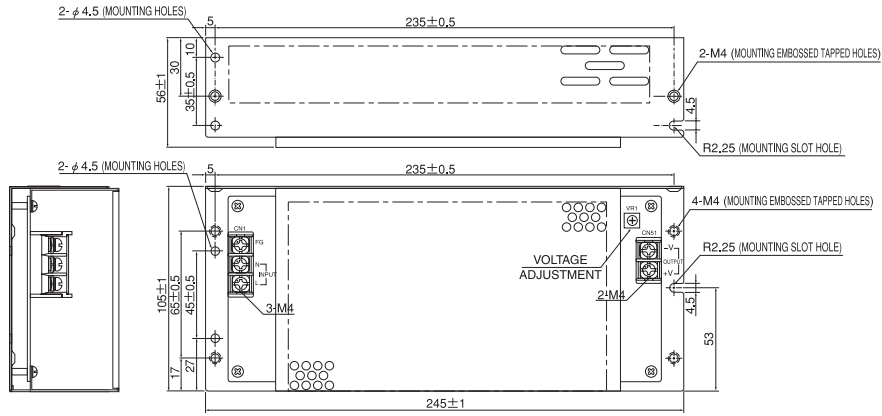

(Unit: mm)

## ZWS240PAF/S (Horizontal terminal type)

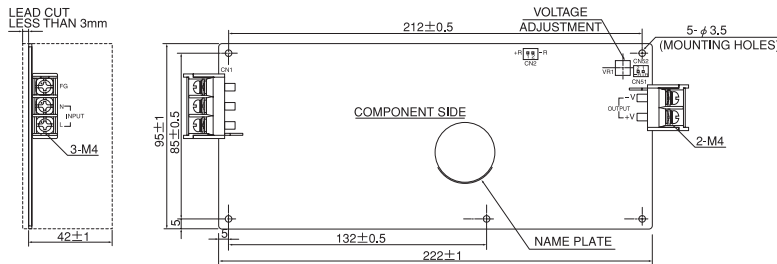

(Unit: mm)

## ZWS240PAF/SL (Horizontal terminal, with L-angle type)

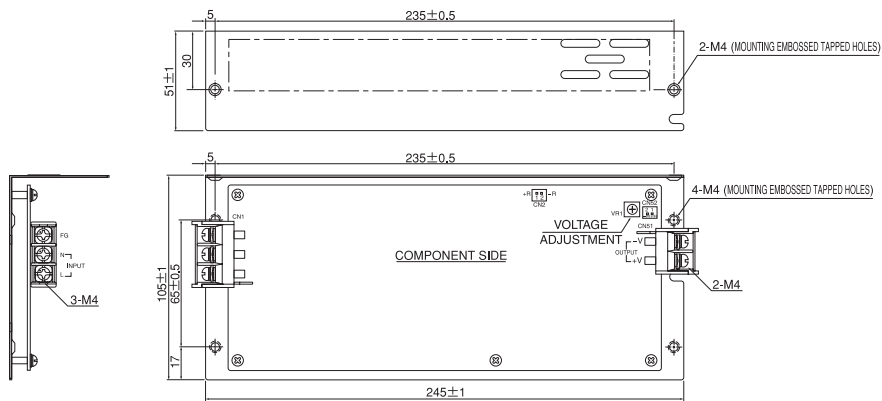

(Unit: mm)

## ZWS240PAF/SA (Horizontal terminal, with Cover type)

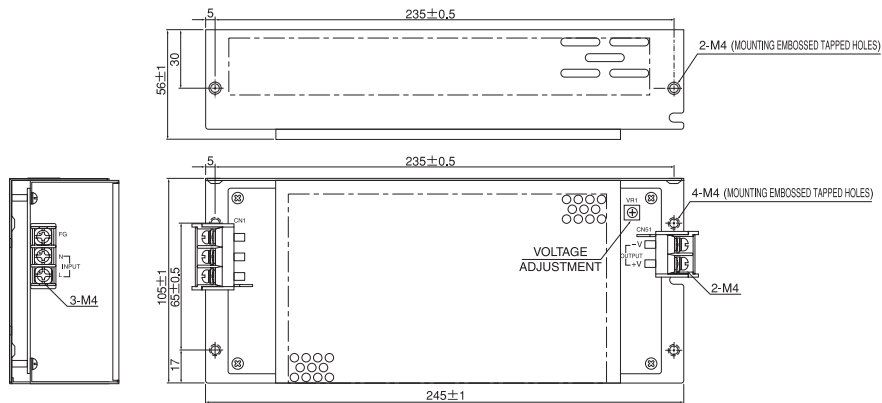

(Unit: mm)