

KEELOQ[®] Code Hopping Decoder*

FEATURES

Security

- Secure storage of manufacturer's key
- Secure storage of transmitter's keys
- NTQ109 compatible learning mode
- Up to six transmitters
- Master transmitter supported
- KEELOQ code hopping technology

Operating

- 3.0V–6.0V operation
- 4 MHz RC oscillator
- Learning indication on repeat
- Auto baud rate detection

Other

- NTQ109 functional replacement
- Stand alone decoder
- On-chip EEPROM for transmitter storage
- Four binary function outputs—15 functions
- 18-pin DIP/SOIC package

Typical Applications

- Automotive remote entry systems
- Automotive alarm systems
- Automotive immobilizers
- Gate and garage openers
- Electronic door locks
- Identity tokens
- Burglar alarm systems

Compatible Encoders

- NTQ106, NTQ105, NTQ104
- HCS200, HCS300/301, HCS360/361

DESCRIPTION

The Microchip Technology Inc. HCS509 is a code hopping decoder designed for secure Remote Keyless Entry (RKE) systems. The HCS509 utilizes the patented KEELOQ code hopping system and high security learning mechanisms to make this a canned solution when used with the HCS encoders to implement a uni-directional remote keyless entry system.

PACKAGE TYPE

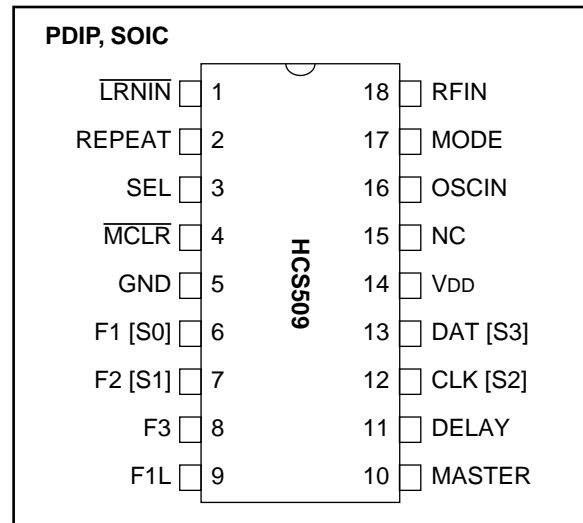

BLOCK DIAGRAM

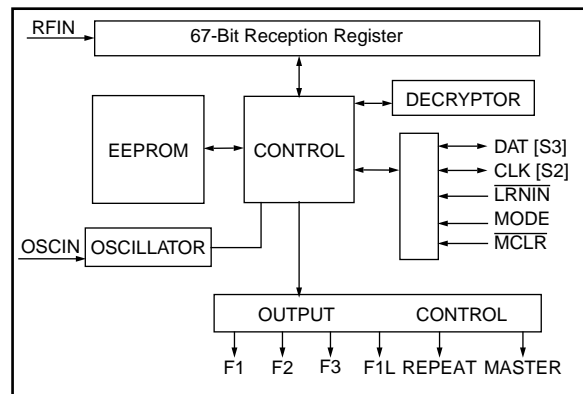

The manufacturer's key, transmitter keys, and synchronization information are stored in protected on-chip EEPROM. The HCS509 uses the DAT and CLK inputs to load the manufacturer's key and cannot be read out of the device.

The HCS509 operates over a wide voltage range of 3.0 volts to 6.0 volts. The decoder employs automatic baud rate detection which allows it to compensate for wide variations in transmitter data rate. The decoder contains sophisticated error checking algorithms to ensure only valid codes are accepted.

1.0 KEELOQ SYSTEM OVERVIEW

1.1 Key Terms

- **Manufacturer's Code** – a 64-bit word, unique to each manufacturer, used to produce a unique encryption key in each transmitter (encoder).
- **Decryption Key** – a unique 64-bit key generated or programmed into the decoder. The decryption key controls the encryption algorithm and is stored in EEPROM on the decoder device.
- **Learn** – The receiver uses the same information that is transmitted during normal operation to derive the transmitter's secret key, decrypt the discrimination value and the synchronization counter in learning mode to match a transmitter to a receiver. The encryption/decryption key is a function of the manufacturer's key and the device serial number.

The HCS encoders and decoders employ the KEELOQ code hopping technology and an encryption algorithm to achieve a high level of security. Code hopping is a method by which the code transmitted from the transmitter to the receiver is different every time a button is pushed. This method, coupled with a transmission length of 66 bits, virtually eliminates the use of code 'grabbing' or code 'scanning'.

1.2 HCS Encoder Overview

The HCS encoders have a small EEPROM array which must be loaded with several parameters before use. The most important of these values are:

- A 28-bit serial number which is meant to be unique for every encoder
- An encryption key that is generated at the time of production
- A 16-bit synchronization value

The serial number for each encoder is programmed by the manufacturer at the time of production. The generation of the encryption key is done using a key generation algorithm (Figure 1-1). Typically, inputs to the key generation algorithm are the serial number of the encoder and a 64-bit manufacturer's code. The manufacturer's code is chosen by the system manufacturer and must be carefully controlled. The manufacturer's code is a pivotal part of the overall system security.

FIGURE 1-1: CREATION AND STORAGE OF ENCRYPTION KEY DURING PRODUCTION

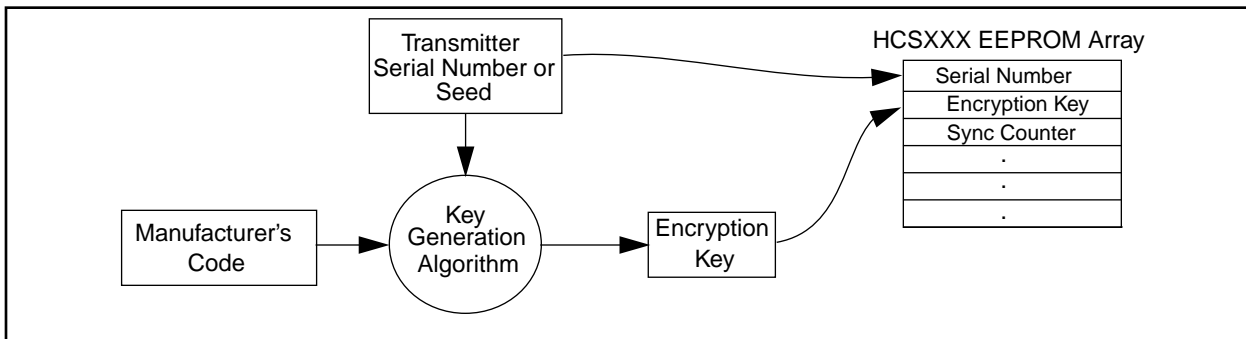

The 16-bit synchronization value is the basis for the transmitted code changing for each transmission and is updated each time a button is pressed. Because of the complexity of the code hopping encryption algorithm, a change in one bit of the synchronization value will result in a large change in the actual transmitted code. There is a relationship (Figure 1-2) between the key values in EEPROM and how they are used in the encoder. Once the encoder detects that a button has been pressed, the encoder reads the button and updates the synchronization counter. The synchronization value is then combined with the encryption key in the encryption algorithm, and the output is 32 bits of encrypted information. This data will change with every button press, hence, it is referred to as the hopping portion of the code word. The 32-bit hopping code is combined with the button information and the serial number to form the code word transmitted to the receiver.

1.3 HCS Decoder Overview

Before a transmitter can be used with a particular receiver, the transmitter must be 'learned' by the receiver. Upon learning a transmitter, information is stored by the receiver so that it may track the transmitter, including the serial number of the transmitter, the current synchronization value for that transmitter, and the same encryption key that is used on the transmitter. If a receiver receives a message of valid format, the serial number is checked and, if it is from a learned transmitter, the message is decrypted and the decrypted synchronization counter is checked against what is stored. If the synchronization value is verified, then the button status is checked to see what operation is needed. Figure 1-3 shows the relationship between some of the values stored by the receiver and the values received from the transmitter.

FIGURE 1-2: BASIC OPERATION OF TRANSMITTER (ENCODER)

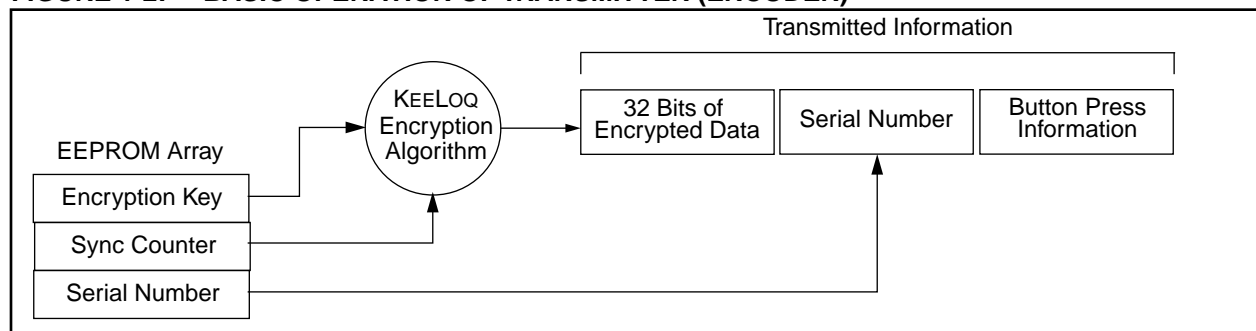
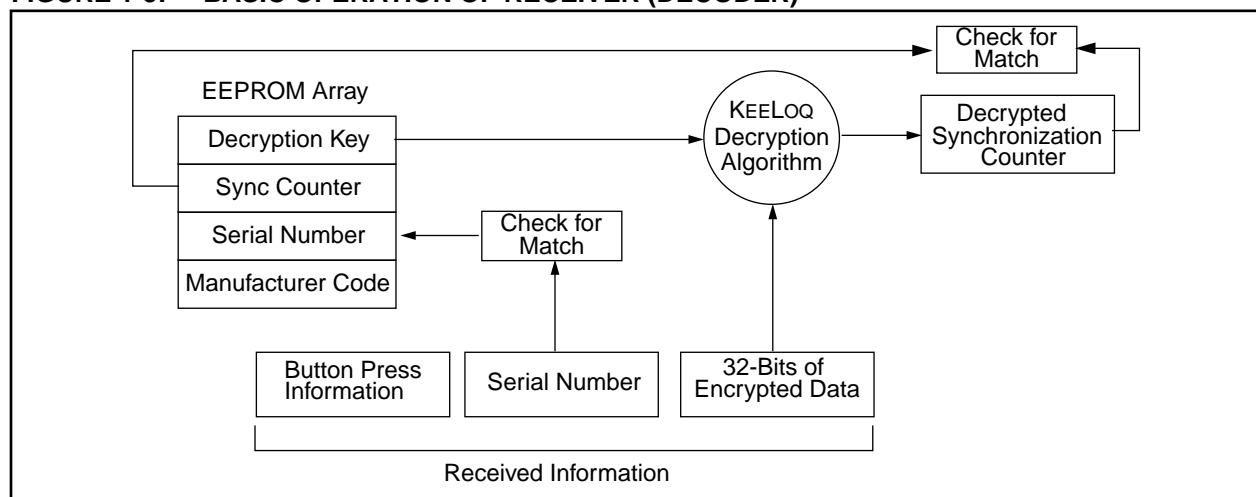

FIGURE 1-3: BASIC OPERATION OF RECEIVER (DECODER)



2.0 PIN ASSIGNMENT

PIN	Decoder Function	I/O ⁽¹⁾	Buffer Type ⁽¹⁾	Description
1	LRNIN	I	TTL	Learn input - initiates learning, 10K pull-up required on input
2	REPEAT	O	TTL	Repeat output - Indicates repeated codes
3	SEL	I	TTL	Connect to VDD
4	MCLR	I	ST	Master clear input
5	Ground	P	—	Ground connection
6	F1 [S0]	O	TTL	Function 1 output (Also S0)
7	F2 [S1]	O	TTL	Function 2 output (Also S1)
8	F3	O	TTL	Function 3 output
9	F1L	O	TTL	Function 1 latched
10	MASTER	O	TTL	Master transmitter output
11	DELAY	O	TTL	Delayed transmission output
12	CLK [S2]	I/O	TTL/ST ⁽²⁾	Clock in programming mode (Also S2 output) (Note 3)
13	DAT [S3]	I/O	TTL/ST ⁽²⁾	Data in programming mode (Also S3 output) (Note 3)
14	VDD	P	—	Power connection
15	NC	—	—	No connection
16	OSCIN (4 MHz)	I	ST	Oscillator in – recommended values 10 k Ω and 10pF
17	MODE	I	TTL	Input to select learning or preprogramming mode
18	RFIN	I	TTL	RF input from receiver

Note 1: P = power, I = in, O = out, and ST = Schmitt Trigger input.

2: This buffer is a Schmitt Trigger input when used in serial programming mode.

3: Pin 12 and Pin 13 have a dual purpose. During reset these pins are used to determine if programming mode is selected in which case they are the clock and data lines. In normal operation mode these pins are the upper 2-bits of the button code [S3 S2].

3.0 DESCRIPTION OF FUNCTIONS

3.1 Master Transmitter

In learning mode the decoder can be set up so that the first transmitter that is learned becomes the master transmitter. The master transmitter will not be erased when more than the maximum transmitters are learned. The master transmitter can be used to implement higher privileges in a system such as activating learning. When the master transmitter is activated the associated function outputs as well as the MASTER output are activated. To implement a master learn the MASTER output can be inverted to control the $\overline{\text{LRNIN}}$ input.

3.2 Delayed Mode

The delayed mode can be used to implement a function associated with activating a transmitter for an extended period of time such as panic. Delayed mode is handled differently for encoders with delay mode transmission commands (NTQ106, HCS360/361) than encoders without delay mode transmission commands (HCS200/300/301). The DELAY output is activated when a "delay transmission command" is received or when the same transmissions are received consecutively for 4 seconds.

3.3 Repeat

The REPEAT output is activated for 50 ms every time a repeated code is received. The REPEAT output is also used to indicate successful learning. The transmitter should be activated during the first and second steps of learning until the REPEAT output goes high.

3.4 Latched

The F1L (Function 1 latched) output can be used to implement a nonvolatile latch function. F1L will change state every time F1 is activated and return to the state it was in after power loss.

4.0 OUTPUT MAPPING

The HCS509 supports the NTQ109's output format. These are: F1, F2, F1L, F3, REPEAT, MASTER, and DELAY outputs. Additional to these outputs the HCS509 also supports a binary output of the function code [S3 S2 S1 S0] which allows the decoder to use all the button codes of the new HCS encoders (Table 4-1).

FIGURE 4-1: FUNCTION OUTPUT TABLE

Function Code	DAT[S3]	CLK[S2]	F3	F2[S1]	F1[S0]	F1L	Description
0001	0	0	0	0	1	T	F1 on NTQ109, F1L toggle/Binary output
0010	0	0	0	1	0	NC	F2 on NTQ109/Binary output
0011	0	0	1	0	0	NC	F3 on NTQ109/Binary output
0100	0	1	0	0	0	NC	Binary output [S3 S2 S1 S0]
0101	0	1	0	0	1	NC	Binary output [S3 S2 S1 S0]
0110	0	1	0	1	0	NC	Binary output [S3 S2 S1 S0]
0111	0	1	0	1	1	NC	Binary output [S3 S2 S1 S0]
1000	1	0	0	0	0	NC	Binary output [S3 S2 S1 S0]
1001	1	0	0	0	1	NC	Binary output [S3 S2 S1 S0]
1010	1	0	0	1	0	NC	Binary output [S3 S2 S1 S0]
1011	1	0	0	1	1	NC	Binary output [S3 S2 S1 S0]
1100	1	1	0	0	0	NC	Binary output [S3 S2 S1 S0]
1101	1	1	0	0	1	NC	Binary output [S3 S2 S1 S0]
1110	1	1	0	1	0	NC	Binary output [S3 S2 S1 S0]
1111	1	1	0	1	1	NC	Binary output [S3 S2 S1 S0]

Note: NC = No Change; T = Toggle.

5.0 MODE CONFIGURATION

The HCS509 decoder has two modes of operation. The nonlearning mode supports up to 4 transmitters and the learning mode supports up to 6 transmitters.

The nonlearning mode must be used where transmitters are preprogrammed at the factory and learning capability is not required. In this mode there need not be a relationship between the serial number and the decryption key.

The learning mode does not store the decryption key but derives it from the serial number and manufacturer's key each time it is required.

In nonlearning mode, the serial number, synchronization counter, and decryption key must be programmed for each transmitter in the system. The manufacturer's key is not required in preprogram mode.

In learning mode, the only information that needs to be programmed is the manufacturer's key. Transmitters are learned into the HCS509 through the normal learn procedure.

6.0 DECODER OPERATION

6.1 Learning a Transmitter to a Receiver

The learning mode is selected when the mode pin is low. In order for a transmitter to be used with a decoder, the transmitter must first be 'learned'. When a transmitter is learned to a decoder, the decoder stores the serial number and current synchronization value in EEPROM. The decoder must keep track of these values for every transmitter that is learned (Figure 6-1). The maximum number of transmitters that can be learned is five and one master transmitter. The decoder must also store the manufacturer's key in order to learn a transmitter and will typically be the same for all decoders in a system.

In learning mode the decoder assigns 6 memory slots. A learning pointer is used to point to the next learning position. The learning pointer can be set up to point to the first (master) memory slot. If LRN_PTR is initialized to the master position, the first transmitter learned will learn in the master position. This transmitter learned into the system will then become the master transmitter. If initialized to the transmitter 1 position, the first transmitter will learn into transmitter 1. Transmitters will be learned into the memory slots until position five is reached. The learning pointer then wraps back to transmitter 1. Transmitters can be erased by repeated learning. However, the master transmitter will be fixed into the system and cannot be erased.

FIGURE 6-1: ASSIGNMENT OF MEMORY SLOTS

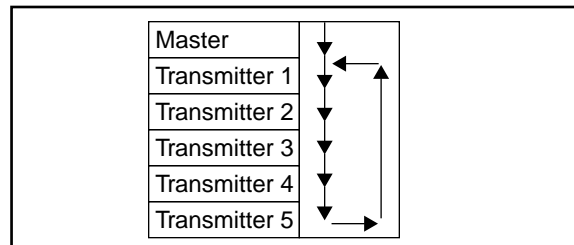

It must be stated that various patents exist on learning strategies and care must be taken not to infringe these patents when using the HCS509 in a system.

6.1.1 LEARNING PROCEDURE

Learning is activated by taking the LRNIN input low for longer than 32 ms. This input requires an external pull-up resistor. The learn input can be either pulled low using a manual learn button or by feeding the MASTER output inverted back to the LRNIN input (Master learn activation).

To learn a new transmitter to the HCS509 decoder, the following sequence is required:

1. Enter learning mode by pulling $\overline{\text{LRNIN}}$ low for longer than 32 ms.
2. Activate the transmitter until the REPEAT output goes high indicating reception of a valid code.
3. Activate the transmitter a second time until the REPEAT goes high again.
4. The transmitter is now learned into the decoder.
5. Repeat steps 1-4 to learn up to 6 transmitters.
6. Learning will be terminated if two non-sequential codes were received or if two acceptable codes were not decoded within 30 seconds.

The following checks are performed on the decoder to determine if the transmission is valid during learn:

- The first code word is checked for bit integrity.
- The hopping code is decrypted.
- The discrimination value is compared to the serial number.
- The second code word is checked for bit integrity.
- The hopping code is decrypted.
- The function codes of the first transmission and second transmission are compared.
- The synchronization counters of the hopping codes are compared to check that they are sequential codes.
- If all the checks pass, the serial number and synchronization counters are stored in EEPROM memory.

Figure 6-2 shows a flow chart of the learn sequence.

Note: Whenever a transmission with the same serial number as the Master transmitter is received during learn, learn will ignore the transmission and wait for the next. Only if a serial number other than the master serial number is received will learn continue. Learn will terminate if no transmissions are received for more than 30 seconds.

FIGURE 6-2: LEARN SEQUENCE

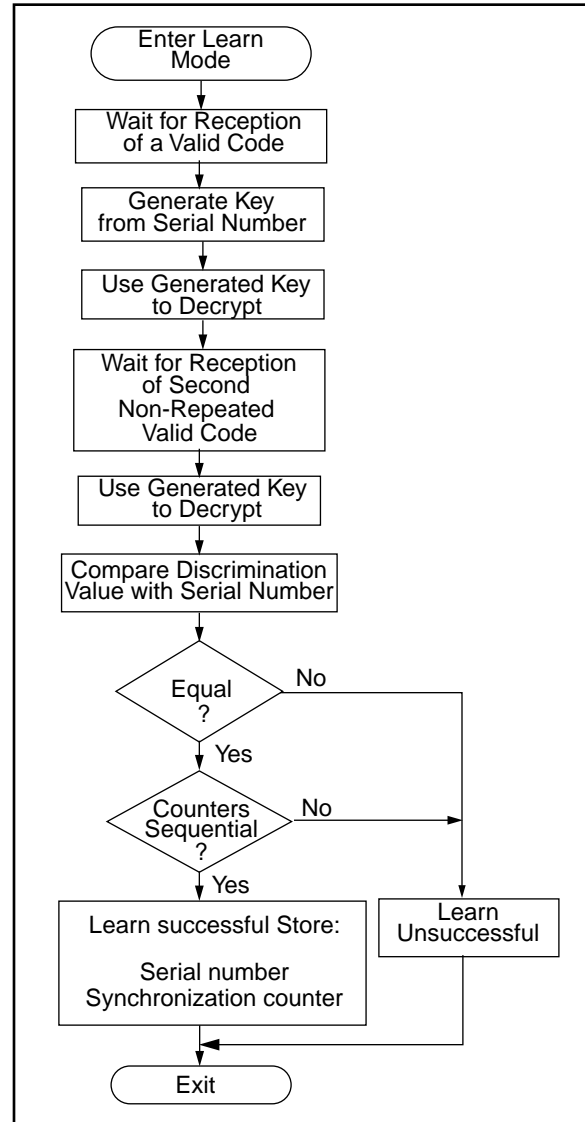

6.2 Preprogramming Transmitters into the Decoder in Nonlearning Mode

The nonlearning mode is selected when the mode pin is high. This mode can be used where there is no relationship between the serial number and the decryption key or where the relationship is not the relationship used on the NTQ109. Transmitter information can be programmed at the time of manufacture. This does not allow the learning of additional transmitters at a later stage.

6.3 Validation of Codes

The HCS509 is a single chip functional replacement for the NTQ109 and NTQ106 decoder chipset. The HCS509 treats all transmitters as NTQ104/105/106 equivalent transmitters. **This means that the full code (66- or 67-bits) is received but only 56 bits are interpreted. Serial numbers are truncated to 24 bits to be compatible with the NTQ104/105/106.**

In a typical decoder operation (Figure 6-3), the key generation on the decoder side is done by taking the serial number from a transmission and combining that with the manufacturer's key to create the same secret key that was used by the transmitter. Once the secret key is obtained, the rest of the transmission can be decrypted. The decoder waits for a transmission and checks the serial number to determine if it is a learned transmitter. If it is, it takes the encrypted portion of the transmission and decrypts it using the decryption key. It uses the discrimination bits to determine if the decryption was valid. If everything up to this point is valid, the synchronization value is evaluated.

6.4 Validation Steps

Validation consists of the following steps:

- Search EEPROM to find the Serial Number Match
- Decrypt the Hopping Code
- Compare the User Bits and the 8 bits of discrimination value with the lower 8 bits of serial number
- Check if the synchronization counter falls within the first synchronization window.
- Check if the synchronization counter falls within the second synchronization window.
- If a valid transmission is found, update the synchronization counter, else use the next transmitter block and repeat the tests.

FIGURE 6-3: DECODER OPERATION

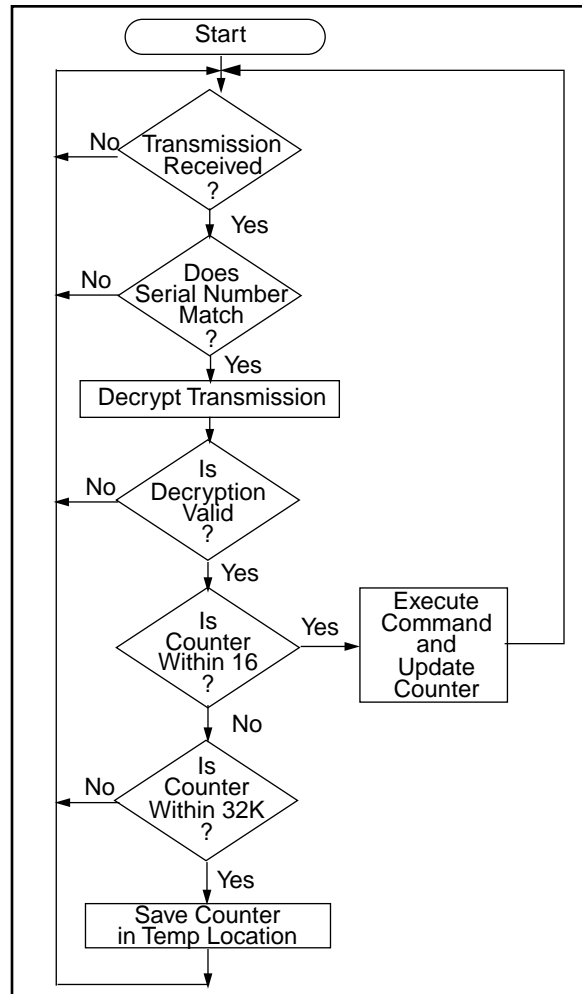

6.5 Synchronization with Decoder

The KEELOQ technology features a sophisticated synchronization technique (Figure 6-4) which does not require the calculation and storage of future codes. If the stored counter value for that particular transmitter and the counter value that was just decrypted are within a formatted window of 16, the counter is stored and the command is executed. If the counter value was not within the single operation window, but is within the double operation window of 32K window, the transmitted synchronization value is stored in temporary location, and it goes back to waiting for another transmission. When the next valid transmission is received, it will check the new value with the one in temporary storage. If the two values are sequential, it is assumed that the counter had just gotten out of the single operation 'window', but is now back in sync, so the new synchronization value is stored and the command executed. If a transmitter has somehow gotten out of the double operation window, the transmitter will not work and must be relearned. Since the entire window rotates after each valid transmission, codes that have been used are part of the 'blocked' (32K) codes and are no longer valid. This eliminates the possibility of grabbing a previous code and retransmitting to gain entry.

FIGURE 6-4: SYNCHRONIZATION WINDOW

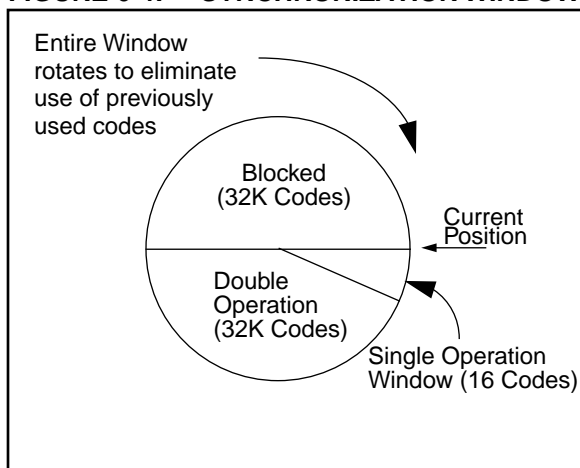

7.0 INTEGRATING THE HCS509 INTO A SYSTEM

The HCS509 can act as a stand alone decoder or be interfaced to a microcontroller. Typical stand alone applications include garage door openers and electronic door locks. In stand alone applications the HCS509 will handle learning, reception, decryption and validation of the received code and generate the appropriate output. For a garage door opener the HCS509 input will be connected to a RF receiver and the output to a relay driver to connect a motor controller.

Typical systems where the HCS509 will be connected to a microcontroller include vehicle and home security systems. The HCS509 input will be connected to a RF receiver and the function outputs to the microcontroller. The HCS509 will handle all the decoding functions and the microcontroller all the system functions.

8.0 DIFFERENCES BETWEEN NTQ109 AND THE HCS509

For those users familiar with the NTQ109, Table 8-1 lists the differences between the NTQ109 and the HCS509 decoders.

TABLE 8-1: DIFFERENCES

Item	Differences	Reason
1	Added binary button outputs. For F1, F2, and F3 function codes the HCS509 will function similarly to the NTQ109, but for F4 and higher the HCS509 displays the binary value of the received function code [S3 S2 S1 S0] by using the F1, F2, DAT, and CLK lines of the HCS509.	This feature is added to enable the use of all the button codes of the new HCSXXX encoders.
2	Learn Mode Pin. This enable the user to select between to modes of operation for the HCS509. The first, allows a maximum of six transmitters but then only the normal Keygen learn method is allowed. The second, allows the user to use a different learning method but requires that the transmitters be preprogrammed into EEPROM using the factory programming interface. In this mode a maximum of four transmitters are allowed.	The HCS509 the decoder uses two memory mappings. In the first mode the decryption key is not stored but derived whenever required, and in the second the decryption key is read from EEPROM and then used.
3	The HCS509 has an added test after reset to determine whether programming mode should be entered or not. This interface is used to initialize the HCS509's learn pointer, manufacturer's key and transmitter memory blocks.	The HCS509 has internal EEPROM memory, and the only access to it is through a factory programming interface. Therefore, to initialize the HCS509 it is necessary to check for the factory programming activation sequence after reset.
4	Automatic Delay Function activation. If a repeated transmission is received for 4 seconds after the function output was activated an automatic delay function will be activated.	The HCS200/300's decoders don't have a delay function option, and to enable these transmitters to emulate the delay function, normally used as a panic, this feature was added.

9.0 KEELOQ ENCODERS

9.1 Transmission Format (PWM)

The KEELOQ encoder transmission is made up of several parts (Figure 9-1). Each transmission begins with a preamble and a header, followed by the encrypted and then the fixed data. The actual data is 56/66/67 bits which consists of 32 bits of encrypted data and 24/34/35 bits of non-encrypted data. Each transmission is followed by a guard period before another transmission can begin. The encrypted portion provides up to four billion changing code combinations and includes the button status bits (based on which buttons were activated) along with the synchronization counter value and some discrimination bits. The non-encrypted portion is comprised of the status bits, the function bits, and the 24/28-bit serial number. The encrypted and non-encrypted combined sections increase the number of combinations to 7.38×10^{19} .

9.2 Code Word Organization

The HCSXXX encoder transmits a 66/67-bit code word when a button is pressed. The 66/67-bit word is constructed from a Fixed Code portion and an Encrypted Code portion (Figure 9-2).

The **Encrypted Data** is generated from four button bits, two overflow counter bits, ten discrimination bits, and the 16-bit synchronization value.

The **Non-encrypted Data** is made up from 2 status bits, 4 function bits, and the 28/32-bit serial number.

FIGURE 9-1: CODE WORD TRANSMISSION FORMAT

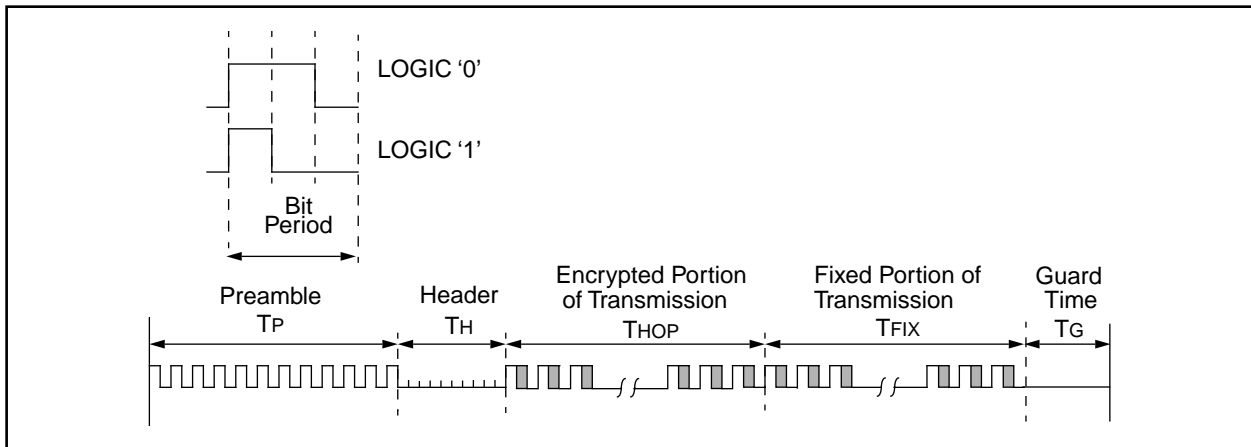
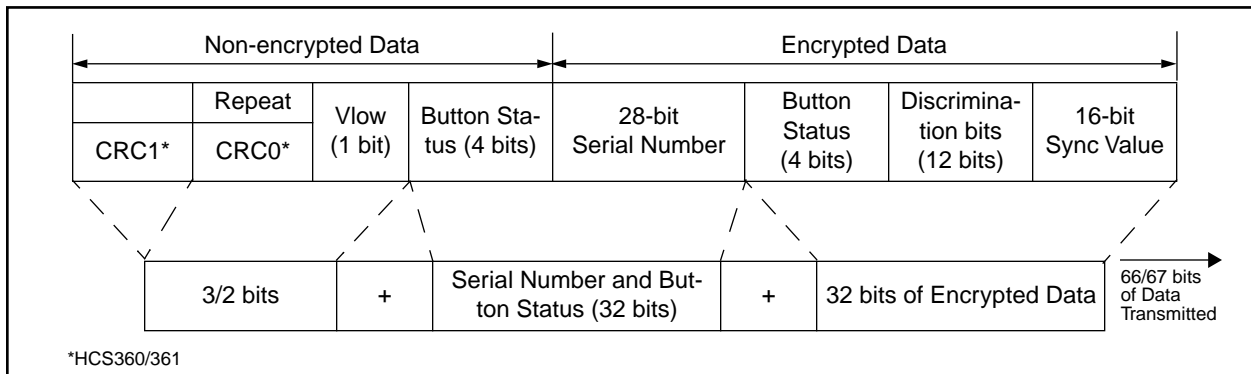

FIGURE 9-2: CODE WORD ORGANIZATION



HCS509

10.0 ELECTRICAL CHARACTERISTICS FOR HCS509

Absolute Maximum Ratings †

Ambient temperature under bias.....	-55°C to +125°C
Storage temperature	-65°C to +150°C
Voltage on any pin with respect to Vss (except VDD).....	-0.6V to VDD +0.6V
Voltage on VDD with respect to Vss.....	0 to +7.5V
Total power dissipation (Note 1).....	800 mW
Maximum current out of Vss pin	150 mA
Maximum current into VDD pin	100 mA
Input clamp current, Iik (Vi < 0 or Vi > VDD).....	± 20 mA
Output clamp current, IOK (VO < 0 or VO > VDD)	± 20 mA
Maximum output current sunk by any I/O pin.....	25 mA
Maximum output current sourced by any I/O pin.....	20 mA

Note: Power dissipation is calculated as follows: $P_{dis} = V_{DD} \times \{I_{DD} - \sum I_{OH}\} + \sum \{(V_{DD} - V_{OH}) \times I_{OH}\} + \sum (V_{OL} \times I_{OL})$

† NOTICE: Stresses above those listed under “Absolute Maximum Ratings” may cause permanent damage to the device. This is a stress rating only and functional operation of the device at those or any other conditions above those indicated in the operation listings of this specification is not implied. Exposure to maximum rating conditions for extended periods may affect device reliability.

TABLE 10-1: DC CHARACTERISTICS

DC CHARACTERISTICS		Standard Operating Conditions (unless otherwise stated)				
		Operating temperature -40°C ≤ TA ≤ +85°C for industrial and 0°C ≤ TA ≤ +70°C for commercial				
Symbol	Characteristic	Min	Typ ^(†)	Max	Units	Conditions
VDD	Supply Voltage	3.0	—	6.0	V	
VPOR	VDD start voltage to ensure Reset	—	VSS	—	V	
SVDD	VDD rise rate to ensure Reset	0.05*	—	—	V/ms	
IDD	Supply Current	—	1.8 7.3	4.5 10	mA mA	FOSC = 4 MHz, VDD = 5.5V (During EEPROM programming)
VIL	Input Low Voltage	VSS	—	0.16 VDD	V	except MCLR = 0.2 VDD
VIH	Input High Voltage	0.48 VDD	—	VDD	V	except MCLR = 0.85 VDD
VOL	Output Low Voltage	—	—	0.6	V	IOL = 8.5 mA, VDD = 4.5V
VOH	Output High Voltage	VDD - 0.7	—	—	V	IOH = -3.0 mA, VDD = 4.5V

† Data in "Typ" column is at 5.0V, 25°C unless otherwise stated. These parameters are for design guidance only and are not tested.

* These parameters are characterized but not tested.

Note: Negative current is defined as coming out of the pin.

TABLE 10-2: AC CHARACTERISTICS

Symbol	Characteristic	Min	Typ	Max	Units	Conditions
FOSC	Oscillator frequency	2.7	4	6.21	MHz	Rext=10K, Cext=10pF
FBAUD	Auto baudrate range	500	—	3200	bps	
TOD	Output delay	48	75	237	ms	
TA	Output activation time	322	500	740	ms	
TRPT	REPEAT activation time	32	50	74	ms	
TLRN	LRNIN activation time	21	32	—	ms	
TMCLR	MCLR low time	150	—	—	ns	
TOV	Time output valid	—	150	222	ms	

FIGURE 10-1: RESET WATCHDOG TIMER, OSCILLATOR START-UP TIMER AND POWER-UP TIMER TIMING

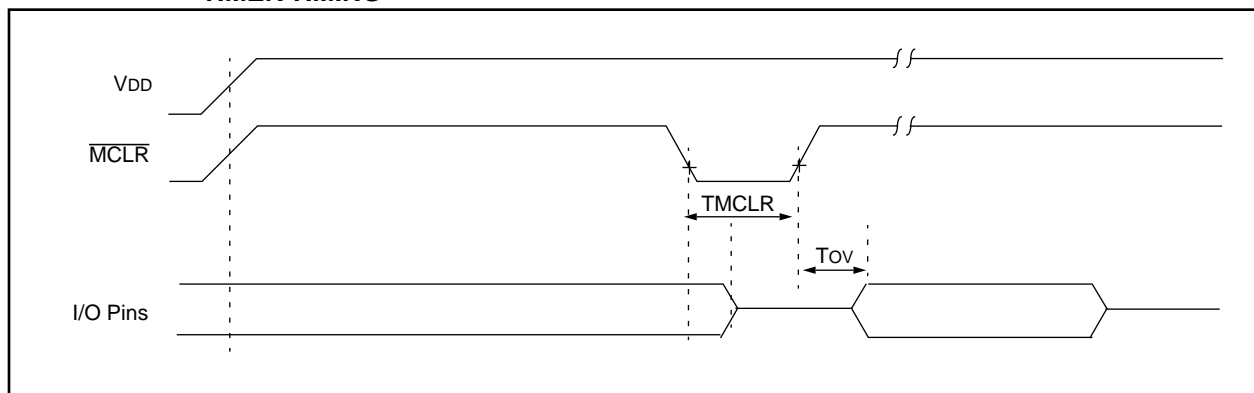

FIGURE 10-2: OUTPUT ACTIVATION

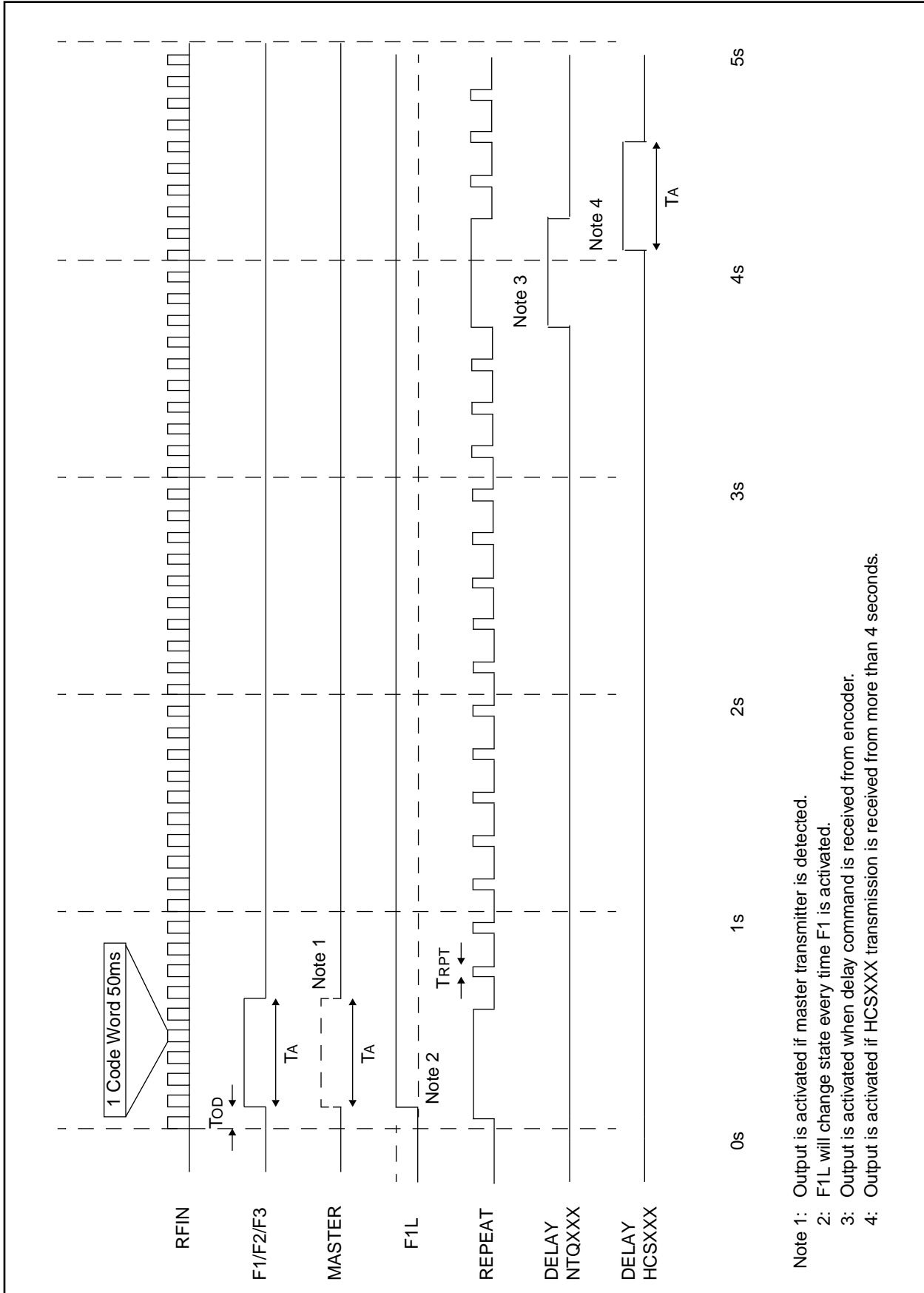
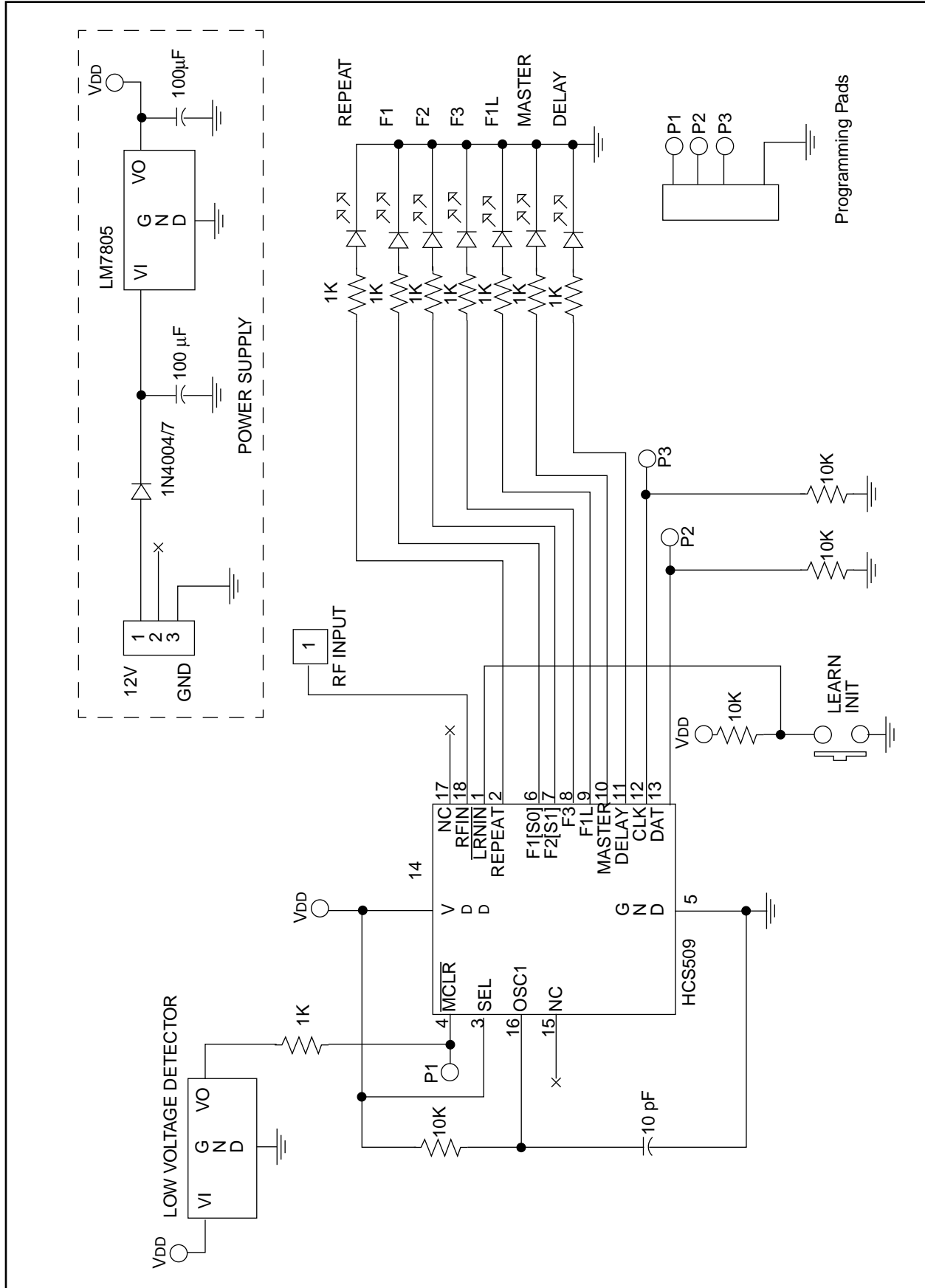

FIGURE 10-3: TEST CIRCUIT



HCS509

HCS509 Product Identification System

To order or to obtain information, e.g., on pricing or delivery, please use the listed part numbers, and refer to the factory or the listed sales offices.

HCS509 —	/P	Package:	P = DIP (300 mil Body), 18-lead SN = SOIC (300 mil body), 18-lead
		Temperature Range:	Blank = 0°C to +70°C I = -40°C to +85°C
		Device:	HCS509 Code Hopping Decoder HCS509T Code Hopping Decoder (Tape and Reel)

AMERICAS

Corporate Office

Microchip Technology Inc.
2355 West Chandler Blvd.
Chandler, AZ 85224-6199
Tel: 602 786-7200 Fax: 602 786-7277
Technical Support: 602 786-7627
Web: <http://www.microchip.com>

Atlanta

Microchip Technology Inc.
500 Sugar Mill Road, Suite 200B
Atlanta, GA 30350
Tel: 770 640-0034 Fax: 770 640-0307

Boston

Microchip Technology Inc.
5 Mount Royal Avenue
Marlborough, MA 01752
Tel: 508 480-9990 Fax: 508 480-8575

Chicago

Microchip Technology Inc.
333 Pierce Road, Suite 180
Itasca, IL 60143
Tel: 708 285-0071 Fax: 708 285-0075

Dallas

Microchip Technology Inc.
14651 Dallas Parkway, Suite 816
Dallas, TX 75240-8809
Tel: 214 991-7177 Fax: 214 991-8588

Dayton

Microchip Technology Inc.
Suite 150
Two Prestige Place
Miamisburg, OH 45342
Tel: 513 291-1654 Fax: 513 291-9175

Los Angeles

Microchip Technology Inc.
18201 Von Karman, Suite 1090
Irvine, CA 92715
Tel: 714 263-1888 Fax: 714 263-1338

New York

Microchip Technology Inc.
150 Motor Parkway, Suite 416
Hauppauge, NY 11788
Tel: 516 273-5305 Fax: 516 273-5335

AMERICAS (continued)

San Jose

Microchip Technology Inc.
2107 North First Street, Suite 590
San Jose, CA 95131
Tel: 408 436-7950 Fax: 408 436-7955

Toronto

Microchip Technology Inc.
5925 Airport Road, Suite 200
Mississauga, Ontario L4V 1W1, Canada
Tel: 905 405-6279 Fax: 905 405-6253

ASIA/PACIFIC

Hong Kong

Microchip Technology
RM 3801B, Tower Two
Metroplaza
223 Hing Fong Road
Kwai Fong, N.T. Hong Kong
Tel: 852 2 401 1200 Fax: 852 2 401 3431

Korea

Microchip Technology
168-1, Youngbo Bldg. 3 Floor
Samsung-Dong, Kangnam-Ku,
Seoul, Korea
Tel: 82 2 554 7200 Fax: 82 2 558 5934

Singapore

Microchip Technology
200 Middle Road
#10-03 Prime Centre
Singapore 188980
Tel: 65 334 8870 Fax: 65 334 8850

Taiwan

Microchip Technology
10F-1C 207
Tung Hua North Road
Taipei, Taiwan, ROC
Tel: 886 2 717 7175 Fax: 886 2 545 0139

EUROPE

United Kingdom

Arizona Microchip Technology Ltd.
Unit 6, The Courtyard
Meadow Bank, Furlong Road
Bourne End, Buckinghamshire SL8 5AJ
Tel: 44 1628 851077 Fax: 44 1628 850259

France

Arizona Microchip Technology SARL
Zone Industrielle de la Bonde
2 Rue du Buisson aux Fraises
91300 Massy - France
Tel: 33 1 69 53 63 20 Fax: 33 1 69 30 90 79

Germany

Arizona Microchip Technology GmbH
Gustav-Heinemann-Ring 125
D-81739 Muenchen, Germany
Tel: 49 89 627 144 0 Fax: 49 89 627 144 44

Italy

Arizona Microchip Technology SRL
Centro Direzionale Colleone Pas Taurus 1
Viale Colleoni 1
20041 Agrate Brianza
Milan Italy
Tel: 39 39 6899939 Fax: 39 39 689 9883

JAPAN

Microchip Technology Intl. Inc.
Benex S-1 6F
3-18-20, Shin Yokohama
Kohoku-Ku, Yokohama
Kanagawa 222 Japan
Tel: 81 45 471 6166 Fax: 81 45 471 6122

6/14/96



All rights reserved.
© 1996, Microchip Technology Inc., USA, 7/196

Information contained in this publication regarding device applications and the like is intended for suggestion only and may be superseded by updates. No representation or warranty is given and no liability is assumed by Microchip Technology Incorporated with respect to the accuracy or use of such information, or infringement of patents or other intellectual property rights arising from such use, or otherwise. Use of Microchip's products as critical components in medical devices is not authorized except with express written approval by Microchip. No licenses are conveyed, implicitly or otherwise, under any intellectual property rights. The Microchip logo and name are registered trademarks of Microchip Technology Inc. in the USA and other countries. All rights reserved. All other trademarks mentioned herein are the property of their