

UV 10.SL - Ultraviolet Detector

Extremely High Sensitivity

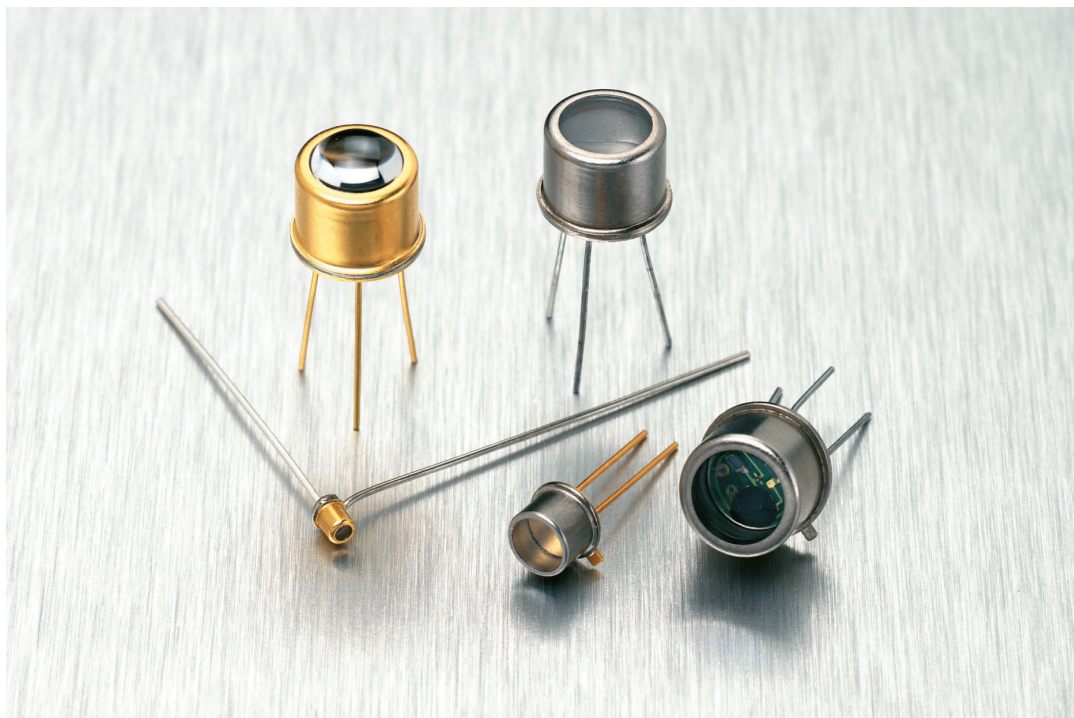

Description

UV 10.SL is made in **TO-5 housing** with lens. It includes the sensitive diode and the standard transmissive window characteristics. Optionally A2 window is available.

PerkinElmer Optoelectronics offers a range of selective sensors for ultraviolet radiation. This sensor series can be equipped with an integrated amplifier and is perfectly suited for the detection of any radiation ranging from 200 nm to 400 nm. High sensitivity, hermetic encapsulation, small dimension (TO-5) and low-cost structure provide suitability for both industrial and consumer applications.

UV detectors from PerkinElmer Optoelectronics are based on silicon-carbide, a material that offers new performance features at reasonable costs. Silicon-carbide provides a unique sensitivity in the spectral range from 200 nm to 400 nm (peak at 280 nm).

Applications

- Burner Controls
- Industrial Controls
- Low-intensity Measurement

Features

- Extremely High Sensitivity
- Housing with Lens
- Solar Blind

UV 10.SL - Ultraviolet Detector Extremely High Sensitivity

Figure 1. Timing Diagram

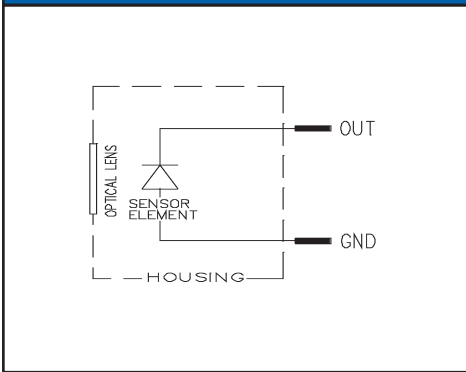

Figure 4. Package Dimensions

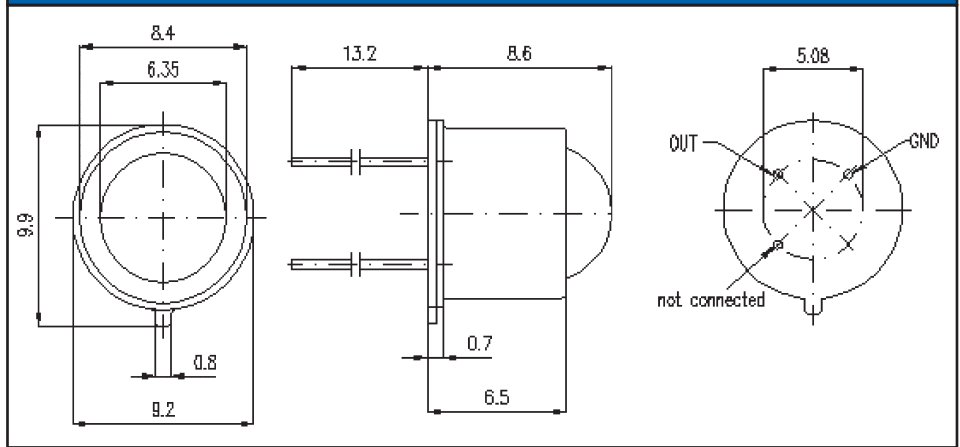

Figure 2. Spectral Curve

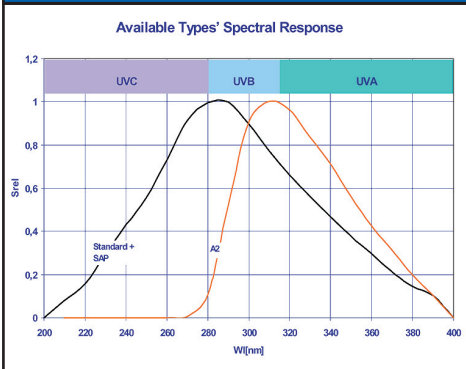
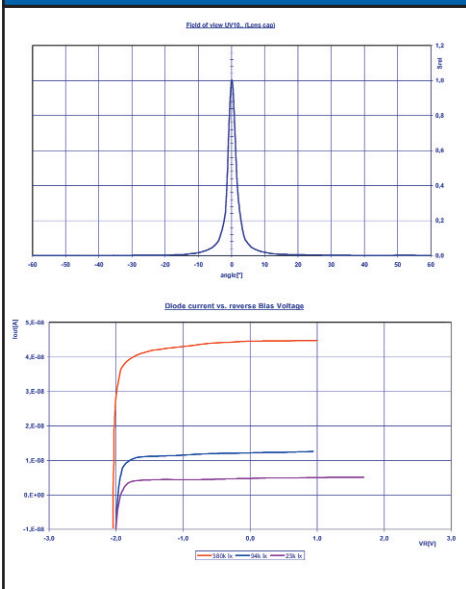

Table 1. UV 10.SL Specifications

Parameters	Typical	Units	Condition
Radiant sensitivity	25	mA/W	standard window
Spectral response	210-380	nm	5% of peak
Wavelength of pk response	280	nm	
Sensitive area	12.5	mm ²	with lens
Selectivity	>10 ⁻⁵		400...2000 nm
Dark current	0.2	fA	
Junction capacitance	21	pF	
Temperature coefficient	-1	%/°C	
Storage temperature	-20 to 80	°C	non permanent
Operating temperature	-20 to 80	°C	non permanent
Window transparency	>210	nm	

Figure 3.



For more information e-mail us at opto@perkinelmer.com or visit our website at www.perkinelmer.com/optoelectronics
All values are nominal; specifications subject to change without notice.

North America:
PerkinElmer Optoelectronics
16800 Trans-Canada Highway
Kirkland, Quebec J7V 8P7 Canada
Toll Free: (877) 734-OPTO (6786)
Phone: +1-450-424-3300
Fax: +1-450-424-3411

Europe:
PerkinElmer Optoelectronics
Wenzel-Jaksch-Str. 31
D-65199 Wiesbaden, Germany
Phone: +49-611-492-430
Fax: +49-611-492-165

Asia:
PerkinElmer Optoelectronics
47 Ayer Rajah Crescent #06-12
Singapore 139947
Phone: +65-6770-4366
Fax: +65-6775-1008

