



12-Bit, 300 MSPS High Speed TxDAC+™ D/A Converter

Preliminary Technical Data

7-1-99

AD9753*

FEATURES

- 12-Bit Dual Muxed Port DAC
- 300 MSPS Output Update Rate
- Excellent SFDR and IMD: 75 dB
- Internal 2x Clock Doubler/PLL
- Differential or Single Ended Clock Input
- On-chip 1.2 V Reference
- Single +3 V Supply Operation
- Power Dissipation: <300 mW @ 3V
- Power Down Mode: 25 mW AVDD @ 3 V
- 48-Lead LQFP

APPLICATIONS

- Communications:
LMDS, LMCS, MMDS
- Basestations
- Digital Synthesis
- Quadrature Modulation

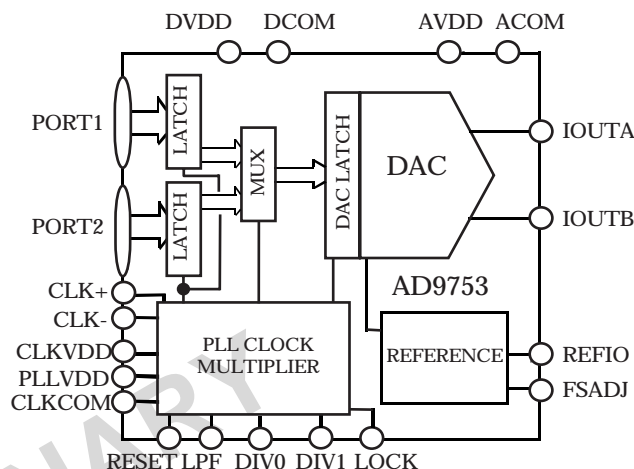

BLOCK DIAGRAM

PRODUCT DESCRIPTION

The AD9753 is a dual muxed port, ultra high-speed, single channel, 12-bit CMOS DAC. It integrates a high-quality 12-bit TxDAC+™ core, a voltage reference, and digital interface circuitry into a small 48-lead LQFP package. The AD9753 offers exceptional AC and DC performance while supporting update rates up to 300MSPS.

The AD9753 has been optimized for ultra high speed applications up to 300MSPS where data rates exceed those possible on a single data interface port DAC. The digital interface consists of two buffered latches as well as control logic. These latches are time multiplexed to the high speed DAC. The internal PLL drives the DAC latch at twice the speed of the externally applied clock and is thus able to interleave the data from the two input channels to the DAC. The resulting output data rate is then twice that of the two input channels. For applications that are sensitive to clock jitter, the internal 2x PLL clock multiplier can be disabled by connecting the PLL power supply pin (PLLVDD) to ground. In PLL disable mode, a 2x clock must be supplied and is divided by two internally.

The CLK inputs (CLK+/CLK-) can be driven either differentially or single ended, with a signal swing as low as 1V pk-pk.

The DAC utilizes a segmented current source architecture. TxDAC+ is a trademark of Analog Devices, Inc.

*Patent pending

Information furnished by Analog Devices is believed to be accurate and reliable. However, no responsibility is assumed by Analog Devices for its use, nor for any infringements of patents or other rights of third parties which may result from its use. No license is granted by implication or otherwise under any patent or patent rights of Analog Devices.

ture combined with a proprietary switching technique to reduce glitch energy and to maximize dynamic accuracy. Differential current outputs support single-ended or differential applications. The differential outputs each provide a nominal full-scale current from 2 to 20mA.

The AD9753 is manufactured on an advanced low cost 0.35μm CMOS process. It operates from a single supply of 2.7 V to 3.6 V and consumes <300 mW of power.

PRODUCT HIGHLIGHTS

1. The AD9753 is a member of a pin-compatible family of high speed TxDAC+s providing 10, 12, and 14 bit resolution.
2. Ultra high speed 300MSPS conversion rate.
3. Dual 12-Bit Latched Multiplexed Input Ports: The AD9753 features a flexible dual-port interface allowing high speed data interfacing.
4. Internal PLL Clock Doubler, differential and single ended clock inputs.
5. Low Power: Complete CMOS DAC function operates on <300 mW from a 2.7 V to 3.6 V single supply. The DAC full-scale current can be reduced for lower power operation.
6. On-chip Voltage Reference: The AD9753 includes a 1.20 V temperature-compensated bandgap voltage reference.

AD9753

DC SPECIFICATIONS (T_{MIN} to T_{MAX} , $AVDD = +3\text{ V}$, $DVDD = +3\text{ V}$, $PLVDD=3\text{V}$, $CLKVDD=3\text{ V}$, $IOUTFS = 20\text{ mA}$, unless otherwise noted)

Parameter	Min	Typ	Max	Units
RESOLUTION	12			Bits
DC ACCURACY ¹				
Integral Linearity Error (INL)	-1.5	0.5	1.5	LSB
Differential Nonlinearity (DNL)	-0.5	0.25	0.5	LSB
ANALOG OUTPUT				
Offset Error	-0.025		+0.025	% of FSR
Gain Error (Without Internal Reference)	-10	±2	+10	% of FSR
Gain Error (With Internal Reference)	-10	±1	+10	% of FSR
Full-Scale Output Current ²	2.0		20.0	mA
Output Compliance Range	-1.0		1.25	V
Output Resistance		100		KΩ
Output Capacitance		5		pF
REFERENCE OUTPUT				
Reference Voltage	1.08	1.20	1.32	V
Reference Output Current ³		100		nA
REFERENCE INPUT				
Input Compliance Range	0.1		1.25	V
Reference Input Resistance			1	MΩ
TEMPERATURE COEFFICIENTS				
Offset Drift		0		ppm of FSR/°C
Gain Drift (Without Internal Reference)		±50		ppm of FSR/°C
Gain Drift (With Internal Reference)		±100		ppm of FSR/°C
Reference Voltage Drift		±50		ppm/°C
POWER SUPPLY				
Supply Voltages A				
VDD	2.7	3.0	3.3	V
DVDD	2.7	3.0	3.3	V
PLLVDD	2.7	3.0	3.3	V
CLKVDD	2.7	3.0	3.3	V
Analog Supply Current (IAVDD)		33		mA
Digital Supply Current (IDVDD)		65		mA
Power Dissipation (3 V, IOUTFS = 20 mA)		300		mW
Power Supply Rejection Ratio ⁴ —AVDD	-0.4		+0.4	% of FSR/V
Power Supply Rejection Ratio ⁴ —DVDD	-0.05		+0.05	% of FSR/V
OPERATING RANGE	-40		+85	°C

NOTES

1 Measured at IOUTA, driving a virtual ground.

2 Nominal full-scale current, IOUTFS, is 32× the IREF current.

3 An external buffer amplifier is recommended to drive any external load.

4 ±5% Power supply variation.

Specifications subject to change without notice.

AD9753

DYNAMIC SPECIFICATIONS (T_{MIN} to T_{MAX}, AVDD = +3 V, DVDD = +3 V, CLKVDD = 3 V, PLLVDD = 0V, IOUTFS = 20 mA, Differential Transformer Coupled Output, 50Ω Doubly Terminated, unless otherwise noted)

Parameter	Min	Typ	Max	Units
DYNAMIC PERFORMANCE				
Maximum Output Update Rate (F _{CLOCK})	300			MSPS
Output Settling Time (t _{st}) (to 0.1%) ⁵		35		ns
Output Propagation Delay (t _{pd}) ⁵		1		ns
Glitch Impulse ⁵		5		pV-s
Output Rise Time (10% to 90%) ⁵		2.5		ns
Output Fall Time (10% to 90%) ⁵		2.5		ns
Output Noise (IOUTFS = 20 mA)		50		pA/√Hz
Output Noise (IOUTFS = 2 mA)		30		pA/√Hz
AC LINEARITY				
Spurious-Free Dynamic Range to Nyquist F _{CLOCK} = 25 MSPS; F _{OUT} = 1.00 MHz				
0 dBFS Output				
TA = +25°C	78	83		dBc
T _{MIN} to T _{MAX}	74			dBc
-6 dBFS Output		79		dBc
-12 dBFS Output		79		dBc
-18 dBFS Output		72		dBc
F _{CLOCK} = 50 MSPS; F _{OUT} = 1.00 MHz		81		dBc
F _{CLOCK} = 50 MSPS; F _{OUT} = 2.51 MHz		79		dBc
F _{CLOCK} = 50 MSPS; F _{OUT} = 5.02 MHz		78		dBc
F _{CLOCK} = 50 MSPS; F _{OUT} = 14.02 MHz		68		dBc
F _{CLOCK} = 50 MSPS; F _{OUT} = 20.2 MHz		62		dBc
Spurious-Free Dynamic Range within a Window F _{CLOCK} = 25 MSPS; F _{OUT} = 1.00 MHz; 2 MHz Span				
TA = +25°C	78	88		dBc
T _{MIN} to T _{MAX}	76			dBc
F _{CLOCK} = 50 MSPS; F _{OUT} = 5.02 MHz; 2 MHz Span		86		dBc
F _{CLOCK} = 150 MSPS; F _{OUT} = 5.04 MHz; 4 MHz Span		84		dBc
Total Harmonic Distortion F _{CLOCK} = 25 MSPS; F _{OUT} = 1.00 MHz				
TA = +25°C		-81	-76	dBc
T _{MIN} to T _{MAX}			-74	dBc
F _{CLOCK} = 50 MHz; F _{OUT} = 2.00 MHz		-78		dBc
F _{CLOCK} = 150 MHz; F _{OUT} = 2.00 MHz		-78		dBc

NOTES

5 Measured single-ended into 50 Ω load.

Specifications subject to change without notice.

AD9753

DIGITAL SPECIFICATIONS (T_{MIN} to T_{MAX}, AVDD = +3 V, DVDD = +3 V, CLKVDD = 3 V, PLLVDD = 3 V, IOUTFS = 20 mA, unless otherwise noted)

Parameter	Min	Typ	Max	Units
DIGITAL INPUTS⁶				
Logic "1"	2.1	3		V
Logic "0"		0	0.9	V
Logic "1" Current	-10		+10	μA
Logic "0" Current	-10		+10	μA
Input Capacitance		5		pF
Input Setup Time (t _s)		2.0		ns
Input Hold Time (t _h)	TBD			ns
Min CLK freq ⁷		6.25		MHz
ABSOLUTE MAXIMUM RATINGS*				
Parameter	With Respect to	Min	Max	Units
AVDD	ACOM	-0.3	+3.9	V
DVDD	DCOM	-0.3	+3.9	V
PLVDD	DCOM	-0.3	+3.9	V
CLKVDD	DCOM	-0.3	+3.9	V
ACOM	DCOM	-0.3	+0.3	V
AVDD	DVDD	-6.5	+3.9	V
CLOCK	DCOM	-0.3	DVDD + 0.3	V
Digital Inputs	DCOM	-0.3	DVDD + 0.3	V
IOUTA, IOUTB	ACOM	-1.0	AVDD + 0.3	V
COMP1	ACOM	-0.3	AVDD + 0.3	V
REFIO, FSADJ	ACOM	-0.3	AVDD + 0.3	V
Junction Temperature			+150	°C
Storage Temperature		-65	+150	°C
Lead Temperature (10 sec)			+300	°C

*Stresses above those listed under Absolute Maximum Ratings may cause permanent damage to the device. This is a stress rating only; functional operation of the device at these or any other conditions above those indicated in the operational sections of this specification is not implied. Exposure to absolute maximum ratings for extended periods may affect device reliability.

ORDERING GUIDE

Model	Temperature Range	Package Description	Package Options	Thermal Characteristics
AD9753AST AD9753-EB	-40°C to +85°C	48-Lead LQFP	ST-48 Evaluation Board	Thermal Resistance 48-Lead LQFP θ _{JA} = 91°C/W

NOTES

6 DIV0, DIV1=(1,1).

7 Min CLK freq only applies when using internal PLL. When PLL is disabled, there is no minimum CLK frequency.

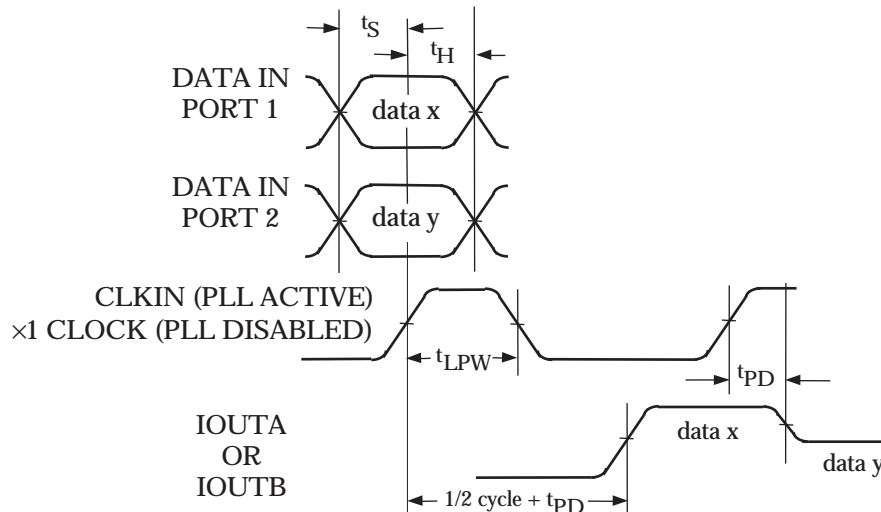
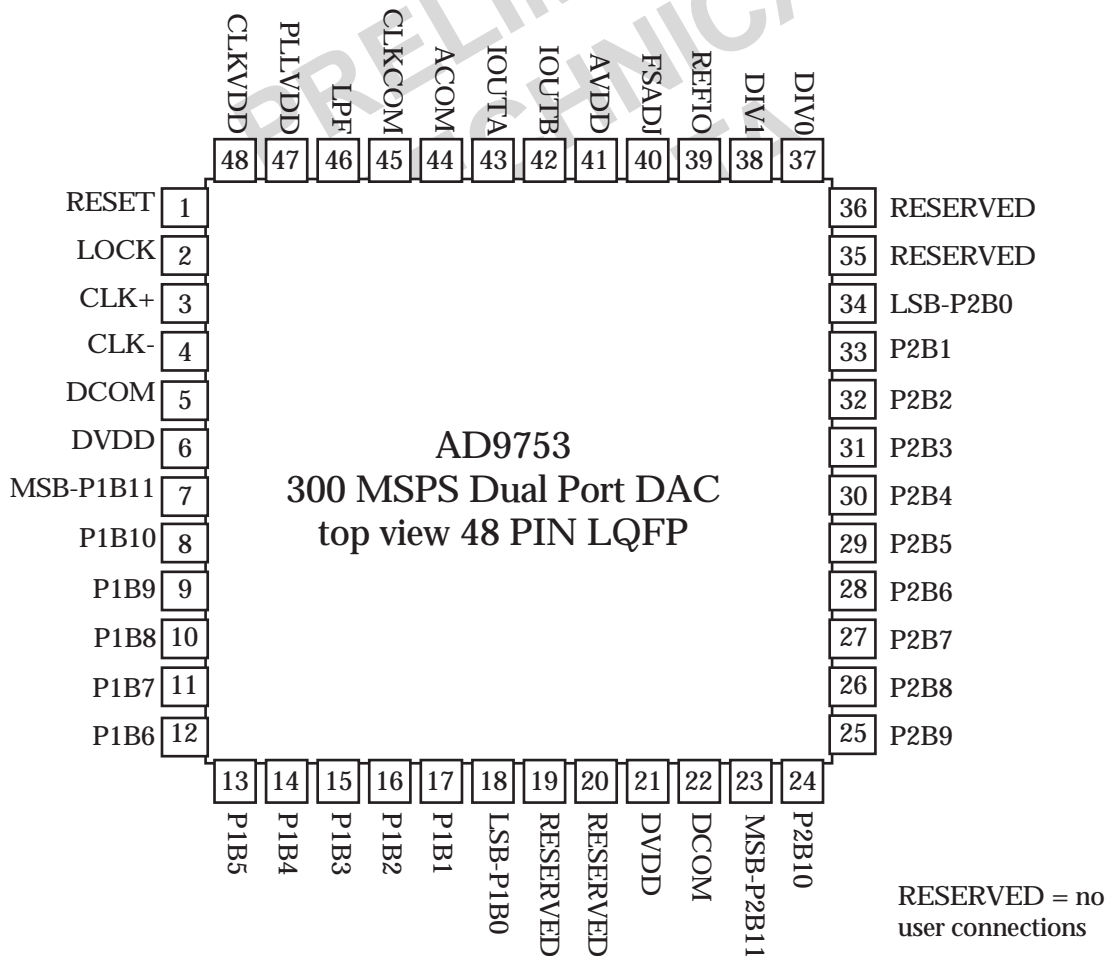

Figure 1. DAC I/O Timing

AD9753

PIN FUNCTION DESCRIPTIONS

Pin No.	Name	Description
43	IOUTA	Differential DAC current output
42	IOUTB	Differential DAC current output
39	REFIO	Reference input/output
37,38	DIV0,DIV1	Control inputs for PLL and input port selector mode, see tables I and II for details
40	FSADJ	Full-scale current output adjust
41	AVDD	Analog Supply Voltage
44	ACOM	Analog Common
6,21	DVDD	Digital Supply Voltage
5,22	DCOM	Digital Common
47	PLLVDD	Phase Locked Loop Supply Voltage
48	CLKVDD	Clock Supply Voltage
45	CLKCOM	Clock and Phase Locked Loop Common
3	CLK+	Differential Clock input
4	CLK-	Differential Clock input
46	LPF	PLL Low Pass Filter
1	RESET	Internal Clock Divider Reset
2	LOCK	PLL Lock Indicator Output
7-18	DB11-P1/DB0-P1	Data bits DB11 to DB0, port 1
23-34	DB11-P2/DB0-P2	Data bits DB11 to DB0, port 2



AD9753

benefits. The first benefit relates directly to the power dissipation of the AD9753, which is proportional to I_{OUTFS} (refer to the POWER DISSIPATION section). The second benefit relates to the 20 dB adjustment, which is useful for system gain control purposes.

The small signal bandwidth of the reference control amplifier is approximately 500KHz and can be used for low frequency small signal multiplying applications.

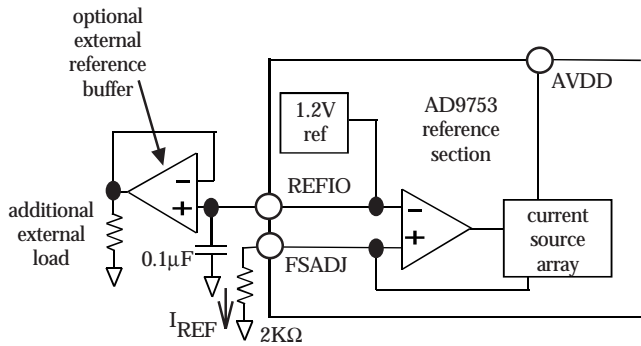

Figure 3. Internal Reference Configuration

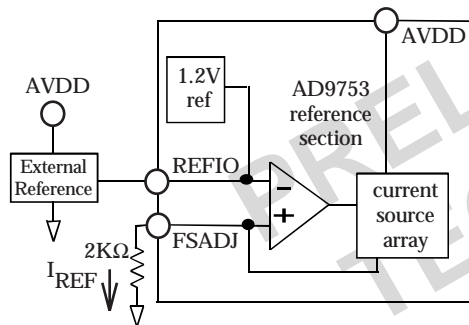

Figure 4. External Reference Configuration

PLL CLOCK MULTIPLIER OPERATION

The Phase Locked Loop (PLL) is intrinsic to the operation of the AD9753 in that it produces the necessary internally synchronized $2\times$ clock for the edge triggered latches, multiplexer and DAC.

With PLLVDD connected to its supply voltage, the AD9753 is in PLL ACTIVE mode. Fig 5 shows a functional block diagram of the AD9753 clock control circuitry with PLL active. The circuitry consists of a phase detector, charge pump, voltage controlled oscillator (VCO), input data rate range control, clock logic circuitry and control input/outputs. The ± 2 logic in the feedback loop allows the PLL to generate the $2\times$ clock needed for the DAC output latch.

Figure 6 defines the input and output timing for the AD9753 with the PLL active. CLK in Figure 6 represents the clock which is generated external to the AD9753 which also updates the input data at ports 1 and 2. CLK may be applied as a single ended signal by

tying CLK- to mid supply and applying CLK to CLK+, or as a differential signal applied to CLK+ and CLK-.

RESET has no purpose when using the internal PLL and should be grounded. When the AD9753 is in PLL ACTIVE mode, LOCK is the output of the internal phase detector. When locked, the lock output in this mode will be a logic "1".

Typically, the VCO can generate outputs of 100 to 400 MHz. The range control is used to keep the VCO operating within its designed range, while allowing input clocks as low as 6.25 MHz. With the PLL active, logic levels at DIV0 and DIV1 determine the divide ratio of the range controller. Table I gives the frequency range of the input clock for the different states of DIV0 and DIV1.

A 392Ω resistor and $1.0\mu\text{f}$ capacitor connected in series from LPF to PLLVDD are required to optimize the phase noise vs. settling/acquisition time characteristics of the PLL. To obtain optimum noise and distortion performance, PLLVDD should be set to a voltage level similar to DVDD.

SNR is partly a function of the jitter generated by the clock circuitry. As a result, any noise on PLLVDD or CLKVDD may decrease the SNR at the output of the DAC. To minimize this potential problem, PLLVDD and CLKVDD can be connected to DVDD using an LC filter network similar to that shown in Figure 7.

DAC TIMING WITH PLL ACTIVE

In PLL ACTIVE mode, port 1 and port 2 input latches are updated on the rising edge of CLK. On the same rising edge, data which was previously stored in the input port 2 latch is written to the DAC output latch. The DAC output will update accordingly after a short propagation delay.

Following the rising edge, at a time equal to half the period of CLK, the data in the port 1 latch will be written to the DAC output latch, again with a corresponding change in the DAC output.

On the next rising edge of CLK, the cycle begins again with the two input port latches being updated, and the DAC output latch being updated with the current data in the port 2 input latch.

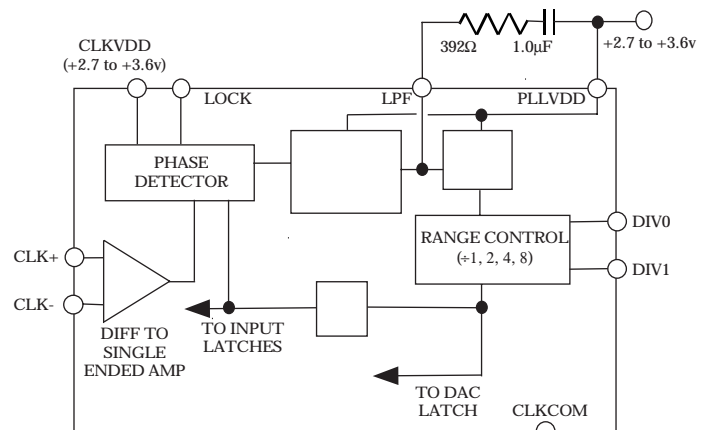

Figure 5. AD9753 Clock Circuitry with PLL Active

AD9753

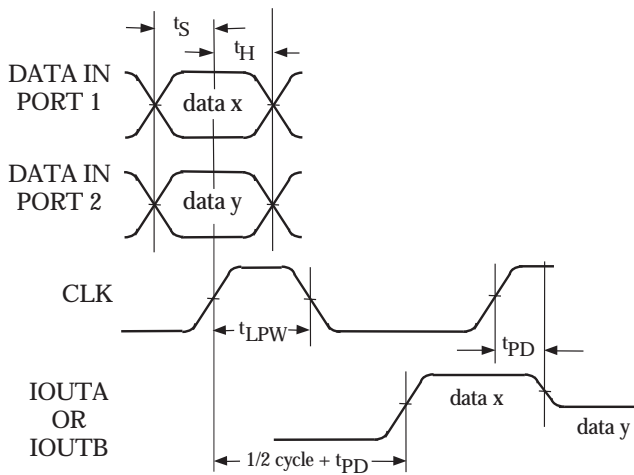

Figure 6a.

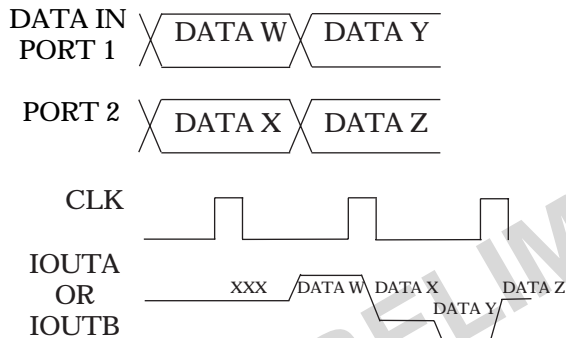

Figure 6b.

Figure 6. DAC Input Timing Requirements with PLL Active

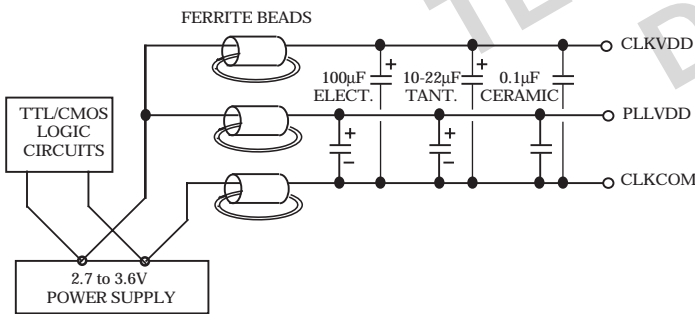

Figure 7. LC Network for Power Filtering

Table I, CLK rates for DIV0, DIV1 levels with PLL active

CLK freq	DIV1	DIV0	Range Controller
50-150 MHz	0	0	+1
25-100 MHz	0	1	+2
12.5-50 MHz	1	0	+4
6.25-25 MHz	1	1	+8

Due to the internal PLL, the time at which the data in the port 1 and port 2 input latches is written to the DAC latch is independent of the duty cycle of CLK.

PLL DISABLED MODE

When PLLVDD is grounded, the PLL is disabled. An external clock must now drive the CLK inputs at the desired DAC output update data rate. The speed and timing of the data present at input ports 1 and 2 is now dependent on whether or not the AD9753 is interleaving the digital input data, or only responding to data on a single port. Figure 8 is a functional block diagram of the AD9753 clock control circuitry with the PLL disabled.

DIV0 and DIV1 no longer control the PLL, but are used to set the control on the input mux for either interleaving or non-interleaving the input data. The different modes for states of DIV0 and DIV1 are given in Table II.

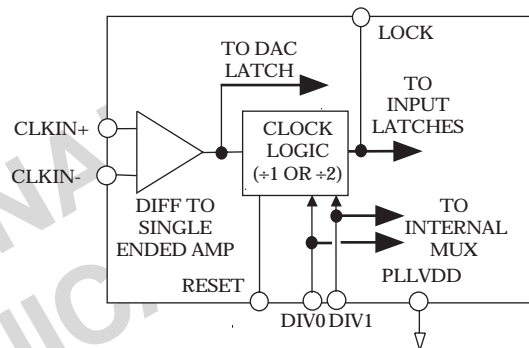

Figure 8. AD9753 Clock Circuitry with PLL Disabled

Table II, Input Mode for DIV0, DIV1 Levels with PLL Disabled

Input Mode	DIV1	DIV0
Interleaved	0	0
Port 1	0	1
Port 2	1	0
NOT ALLOWED	1	1

INTERLEAVING DATA WITH PLL DISABLED

The relationship between the internal and external clocks in this mode is shown in Figure 9. A clock at the output update data rate ($2\times$ the input data rate) must be applied to the CLK inputs. The input latches are now updated by the internally generated $1\times$ clock, while the DAC latch is updated by the external $2\times$ clock. A delayed version of the $1\times$ clock is available at the LOCK pin. Updates to the data at input ports 1 and 2 should be synchronized to the rising edge of the external $2\times$ clock which corresponds to the rising edge of the $1\times$ internal clock as shown in Figure 9. To ensure this synchronization, a logic "1" should be momentarily applied to the RESET pin on power up, before CLK is applied.

AD9753

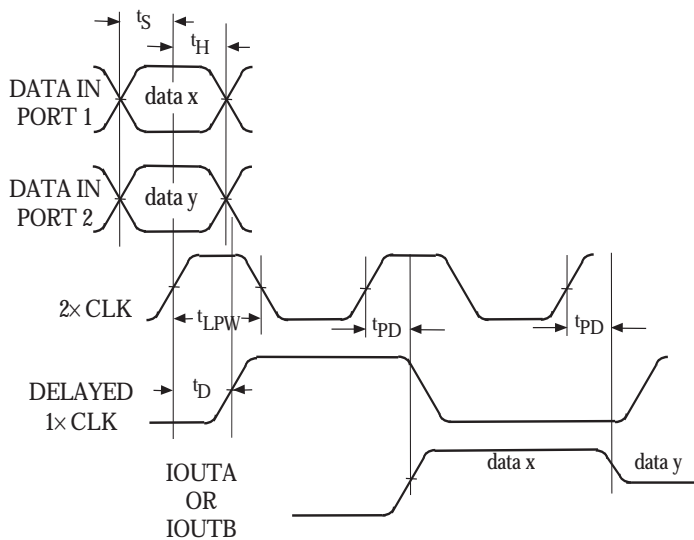

Figure 9. AD9753 Timing Requirements, Interleaving Data with PLL Disabled

NON-INTERLEAVED DATA WITH PLL DISABLED

If the data at only one port is required, no interleaving is done, and the AD9753 interface operates as a typical double buffered latch. On the rising edge of the 1x clock, input latch 1 or 2 is updated with the present input data. On the next rising edge, the DAC latch is updated and a propagation time later the DAC output reflects this change. Figure 10 represents the AD9753 timing in this mode.

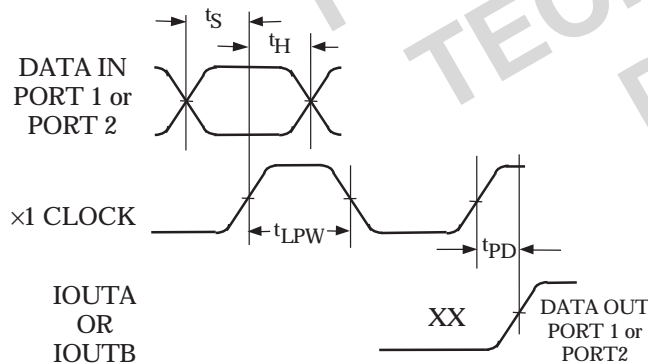

Figure 10. AD9753 Timing Requirements, Non-Interleaved Data with PLL Disabled

DAC TRANSFER FUNCTION

The AD9753 provides complementary current outputs, IOUTA and IOUTB. IOUTA will provide a near full-scale current output, IOUTFS, when all bits are high (i.e., DAC CODE = 4095) while IOUTB, the complementary output, provides no current. The current output appearing at IOUTA and IOUTB is a function of both the input code and IOUTFS and can be expressed as:

$$I_{OUTA} = (DAC\ CODE/4096) \times I_{OUTFS} \quad (1)$$

$$I_{OUTB} = (4095 - DAC\ CODE)/4096 \times I_{OUTFS} \quad (2)$$

where $DAC\ CODE = 0$ to 4095 (i.e., Decimal Representation).

As mentioned previously, IOUTFS is a function of the reference current IREF, which is nominally set by a reference voltage, VREFIO and external resistor RSET. It can be expressed as:

$$I_{OUTFS} = 32 \times I_{REF} \quad (3)$$

$$\text{where } I_{REF} = V_{REFIO}/R_{SET} \quad (4)$$

The two current outputs will typically drive a resistive load directly or via a transformer. If dc coupling is required, IOUTA and IOUTB should be directly connected to matching resistive loads, RLOAD, that are tied to analog common, ACOM. Note, RLOAD may represent the equivalent load resistance seen by IOUTA or IOUTB as would be the case in a doubly terminated 50Ω or 75Ω cable. The single-ended voltage output appearing at the IOUTA and IOUTB nodes is simply :

$$V_{OUTA} = I_{OUTA} \times R_{LOAD} \quad (5)$$

$$V_{OUTB} = I_{OUTB} \times R_{LOAD} \quad (6)$$

Note the full-scale value of VOUTA and VOUTB should not exceed the specified output compliance range to maintain specified distortion and linearity performance.

$$V_{DIFF} = (I_{OUTA} - I_{OUTB}) \times R_{LOAD} \quad (7)$$

Substituting the values of IOUTA, IOUTB and IREF; VDIFF can be expressed as:

$$V_{DIFF} = \{(2\ DAC\ CODE - 4095)/4096\} \times (32\ R_{LOAD}/R_{SET}) \times V_{REFIO} \quad (8)$$

These last two equations highlight some of the advantages of operating the AD9753 differentially. First, the differential operation will help cancel common-mode error sources associated with IOUTA and IOUTB such as noise, distortion and dc offsets. Second, the differential code dependent current and subsequent voltage, VDIFF, is twice the value of the single-ended voltage output (i.e., VOUTA or VOUTB), thus providing twice the signal power to the load.

Note, that the gain drift temperature performance for a single-ended (VOUTA and VOUTB) or differential output (VDIFF) of the AD9753 can be enhanced by selecting temperature tracking resistors for RLOAD and RSET due to their ratiometric relationship as shown in Equation 8.

ANALOG OUTPUTS

The AD9753 produces two complementary current outputs, IOUTA and IOUTB, which may be configured for single-ended or differential operation. IOUTA and IOUTB can be converted into complementary single-ended voltage outputs, VOUTA and VOUTB, via a load resistor, RLOAD, as described in the DAC TRANSFER FUNCTION section by Equations 5 through 8. The differential voltage, VDIFF, existing between VOUTA and VOUTB can also be converted to a single-ended voltage via a transformer or differential amplifier configuration. The

AD9753

ac performance of the AD9753 is optimum and specified using a differential transformer coupled output in which the voltage swing at IOUTA and IOUTB is limited to ± 0.5 V. If a single-ended unipolar output is desirable, IOUTA should be selected as the output, with IOUTB grounded.

The distortion and noise performance of the AD9753 can be enhanced when it is configured for differential operation. The common-mode error sources of both I_{OUTA} and I_{OUTB} can be significantly reduced by the common-mode rejection of a transformer or differential amplifier. These common-mode error sources include even-order distortion products and noise. The enhancement in distortion performance becomes more significant as the frequency content of the reconstructed waveform increases. This is due to the first order cancellation of various dynamic common-mode distortion mechanisms, digital feedthrough and noise.

Performing a differential-to-single-ended conversion via a transformer also provides the ability to deliver twice the reconstructed signal power to the load (i.e., assuming no source termination). Since the output currents of IOUTA and IOUTB are complementary, they become additive when processed differentially. A properly selected transformer will allow the AD9753 to provide the required power and voltage levels to different loads. Refer to APPLYING THE AD9753 section for examples of various output configurations.

The output impedance of IOUTA and IOUTB is determined by the equivalent parallel combination of the PMOS switches associated with the current sources and is typically 100 K Ω in parallel with 5 pF. It is also slightly dependent on the output voltage (i.e., V_{OUTA} and V_{OUTB}) due to the nature of a PMOS device. As a result, maintaining IOUTA and/or IOUTB at a virtual ground via an I-V op amp configuration will result in the optimum dc linearity. Note the INL/DNL specifications for the AD9753 are measured with IOUTA maintained at a virtual ground via an op amp.

IOUTA and IOUTB also have a negative and positive voltage compliance range that must be adhered to in order to achieve optimum performance. The negative output compliance range of -1.0 V is set by the breakdown limits of the CMOS process. Operation beyond this maximum limit may result in a breakdown of the output stage and affect the reliability of the AD9753.

The positive output compliance range is slightly dependent on the full-scale output current, I_{OUTFS} . It degrades slightly from its nominal 1.25 V for an $I_{OUTFS} = 20$ mA to 1.00 V for an $I_{OUTFS} = 2$ mA. The optimum distortion performance for a single-ended or differential output is achieved when the maximum full-scale signal at IOUTA and IOUTB does not exceed 0.5 V. Applications requiring the AD9753's output (i.e., V_{OUTA} and/or V_{OUTB}) to extend its output compliance range should size R_{LOAD} accordingly. Operation beyond this compliance range will adversely affect the

AD9753's linearity performance and subsequently degrade its distortion performance.

DIGITAL INPUTS

The AD9753's digital input consists of two channels of 12 data input pins each and a pair of differential clock input pins. The 12-bit parallel data inputs follow standard straight binary coding where DB11 is the most significant bit (MSB) and DB0 is the least significant bit (LSB). IOUTA produces a full-scale output current when all data bits are at logic 1. IOUTB produces a complementary output with the full-scale current split between the two outputs as a function of the input code.

The digital interface is implemented using an edge-triggered master slave latch. With the PLL active, the DAC output is updated twice for every input clock period, as shown in Figure 6, 9 and 10, and is designed to support a clock input rate as high as 150 MSPS. With the PLL active, this gives a DAC output update rate of 300MSPS. The clock can be operated at any duty cycle that meets the specified latch pulse width. The setup and hold times can also be varied within the clock cycle as long as the specified minimum times are met, although the location of these transition edges may affect digital feedthrough and distortion performance. Best performance is typically achieved when the input data transitions on the falling edge of a 50% duty cycle clock.

The digital inputs are CMOS-compatible with logic thresholds, VTHRESHOLD, set to approximately half the digital positive supply (DVDD) or

$$V_{THRESHOLD} = DVDD/2 (\pm 20\%)$$

The internal digital circuitry of the AD9753 is capable of operating over a digital supply range of 2.7 V to 3.6 V. As a result, the digital inputs can also accommodate TTL levels when DVDD is set to accommodate the maximum high level voltage of the TTL drivers $V_{OH(MAX)}$. A DVDD of 3 V to 3.3 V will typically ensure proper compatibility with most TTL logic families. Figure 11 shows the equivalent digital input circuit for the data and clock inputs.

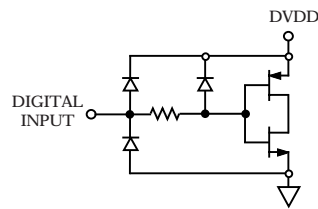

Figure 11. Equivalent Digital Input

AD9753

The AD9753 features a flexible differential clock input operating from separate supplies (i.e., CLKVDD, CLKCOM) to achieve optimum jitter performance.

The two clock inputs, CLK+ and CLK-, can be driven from a single-ended or differential clock source. For single ended operation, CLK+ should be driven by a logic source while CLK- should be set to the threshold voltage of the logic source. This can be done via a resistor divider/capacitor network as shown in Figure 12a. For differential operation, both CLK+ and CLK- should be biased to CLKVDD/2 via a resistor divider network as shown in Figure 12b.

Since the output of the AD9753 is capable of being updated at up to 300 MSPS, the quality of the clock and data input signals are important in achieving the optimum performance. Operating the AD9753 with reduced logic swings and a corresponding digital supply (DVDD) will result in the lowest data feedthrough and on-chip digital noise. The drivers of the digital data interface circuitry should be specified to meet the minimum setup and hold times of the AD9753 as well as its required min/max input logic level thresholds.

Digital signal paths should be kept short and run lengths matched to avoid propagation delay mismatch. The insertion of a low value resistor network (i.e., 20 Ω to 100 Ω) between the AD9753 digital inputs and driver outputs may be helpful in reducing any overshooting and ringing at the digital inputs that contribute to data feedthrough. For longer run lengths and high data update rates, strip line techniques with proper termination resistors should be considered to maintain “clean” digital inputs.

The external clock driver circuitry should provide the AD9753 with a low jitter clock input meeting the min/max logic levels while providing fast edges. Fast clock edges will help minimize any jitter that will manifest itself as phase noise on a reconstructed waveform. Thus, the clock input should be driven by the fastest logic family suitable for the application.

Note that the clock input could also be driven via a sine wave, which is centered around the digital threshold (i.e., DVDD/2) and meets the min/max logic threshold. This will typically result in a slight degradation in the phase noise, which becomes more noticeable at higher sampling rates and output frequencies. Also, at higher sampling rates, the 20% tolerance of the digital logic threshold should be considered since it will affect the effective clock duty cycle and, subsequently, cut into the required data setup and hold times.

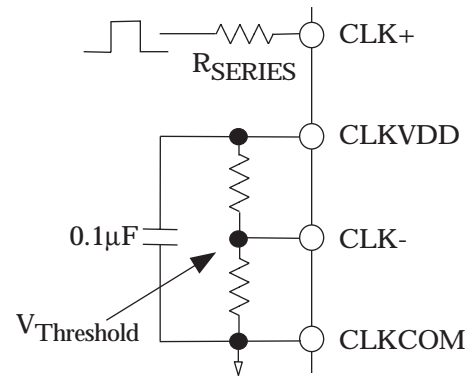

Figure 12a. Single Ended Clock Interface

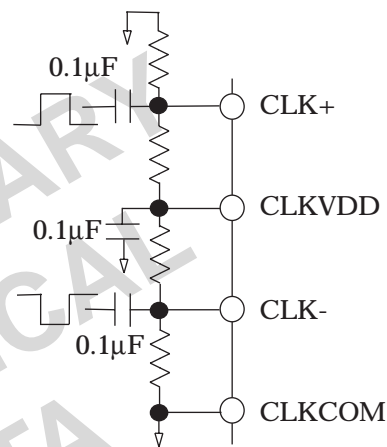
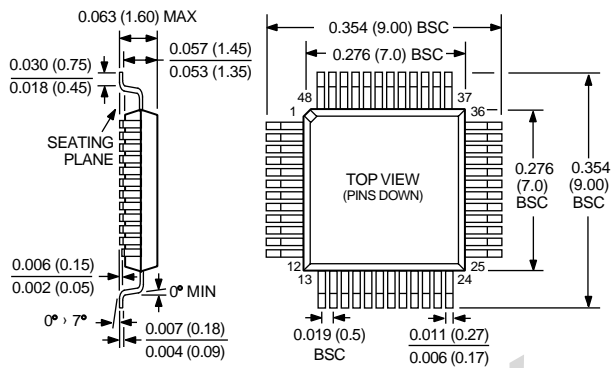

Figure 12b. Differential Clock Interface

**48 pin LQFP package
(ST-48)**



PRELIMINARY
TECHNICAL
DATA