

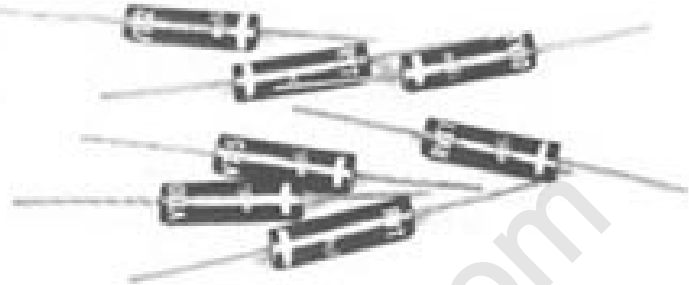

VT RVT

HIGH VOLTAGE 50 mA
SILICON RECTIFIERS

- SMALL SIZE MOLDED PACKAGE
- PRV 10,000 TO 15,000 VOLTS
- FAST RECOVERY (R_SERIES)
- AVALANCHE CHARACTERISTICS
- LOW LEAKAGE



EDI Type	PRV Volts	REVERSE RECOVERY TIME (Fig.4)
VT1000	10,000	-
VT1200	12,000	-
VT1500	15,000	-
RVT1000	10,000	100 ns max.
RVT1200	12,000	100 ns max.
RVT1500	15,000	100 ns max.

ELECTRICAL CHARACTERISTICS (at $T_A=25^\circ\text{C}$ Unless Otherwise Specified)

Average Rectified Forward Current @ 50°C , I_o	50 mA
Max. Peak Surge Current, I_{FSM} (8.3ms)	5 Amp
Max. Forward Voltage Drop @ 50mA, V_F	28Volts
Max. DC Reverse Current @ PRV and 25°C , I_R	1 μA
Max. DC Reverse Current @ PRV and 100°C , I_R	25 μA
Ambient Operating Temperature Range, T_A	-55 to + 125°C
Storage Temperature Range, T_{STG}	-55 to + 150°C

NOTES:

1. It is recommended that a proper heat sink be used on the terminals of this device between the body and soldering point to prevent damage from excess heat.
2. If operated over 10,000v/inch in length, devices should be immersed in oil or re-encapsulated.

EDI reserves the right to change these specifications at any time without notice.

FIG.1

OUTPUT CURRENT vs AMBIENT TEMPERATURE

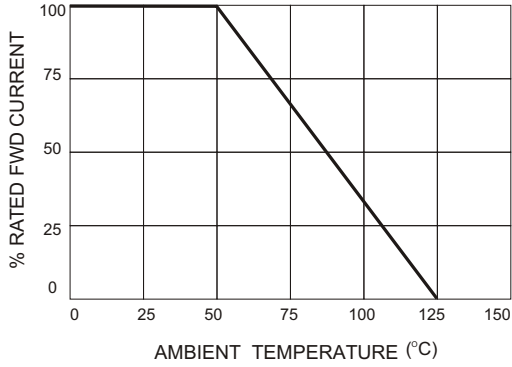

FIG.2

NON-REPETITIVE SURGE CURRENT

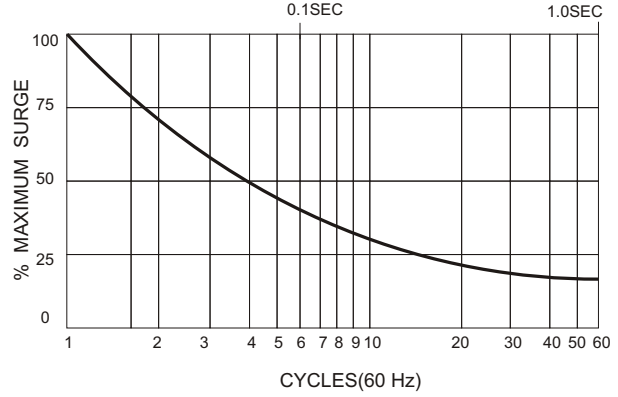
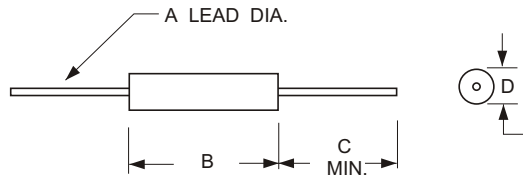

FIG.3

MECHANICAL
Leads-solid silver



Markings-Cathode band
and device type

	INCHES	MM
A	0.02	0.5
B	0.60	15.2
C	0.50	12.7
D	0.16	4.0

FIG.4

REVERSE RECOVERY TEST METHOD

RECOVERY WAVE FORM

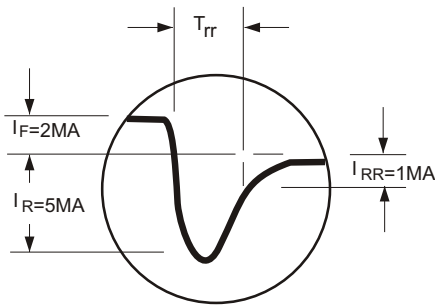

WAVE FORMS

RECOVERY WA VE FORM

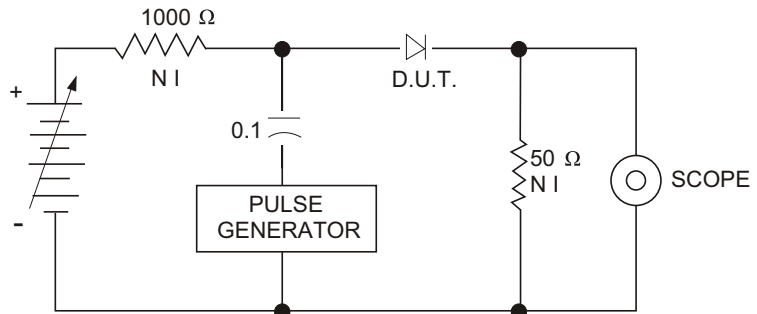

CIRCUIT

ELECTRONIC DEVICES, INC. DESIGNERS AND MANUFACTURERS OF SOLID STATE DEVICES SINCE 1951.

21 GRAY OAKS AVENUE * YONKERS, NEW YORK 10710 914-965-4400 * FAX 914-965-5531 * 1-800-678-0828

e-mail:sales@ediododes.com * website: <http://www.ediododes.com>