



Fractional-N / Integer-N PLL Synthesizer

Preliminary Technical Data

ADF4150

FEATURES

- Fractional-N synthesizer and integer-N synthesizer
- Programmable divide-by-1/2/4/8 or 16 output
- 3.0 V to 3.6 V power supply
- 1.8 V logic compatibility
- Separate charge pump supply (V_P) allows extended tuning voltage in 3 V systems
- Programmable dual-modulus prescaler of 4/5 or 8/9
- Programmable output power level
- RF output mute function
- 3-wire serial interface
- Analog and digital lock detect
- Switched bandwidth fast-lock mode
- Cycle slip reduction

APPLICATIONS

- Wireless infrastructure (WCDMA, TD-SCDMA, WiMax, GSM, PCS, DCS, DECT)
- Test equipment
- Wireless LANs, CATV equipment
- Clock Generation

GENERAL DESCRIPTION

The ADF4150 allows implementation of fractional-N or integer-N phase-locked loop (PLL) frequency synthesizers if used with an external Voltage Controlled Oscillator (VCO), loop filter and external reference frequency.

The ADF4150 is for use with external VCO parts and is software compatible with the ADF4350. The VCO frequency can be divided-by 1/2/4/8 or 16 to allow the user to generate RF output frequencies as low as 31.25 MHz. For applications that require isolation the RF output stage can be muted. The mute function is both pin and software controllable.

Control of all the on-chip registers is through a simple 3-wire interface. The device operates with a power supply ranging from 3.0 V to 3.6 V and can be powered down when not in use.

The ADF4150 is available in a 4mm x 4mm package.

FUNCTIONAL BLOCK DIAGRAM

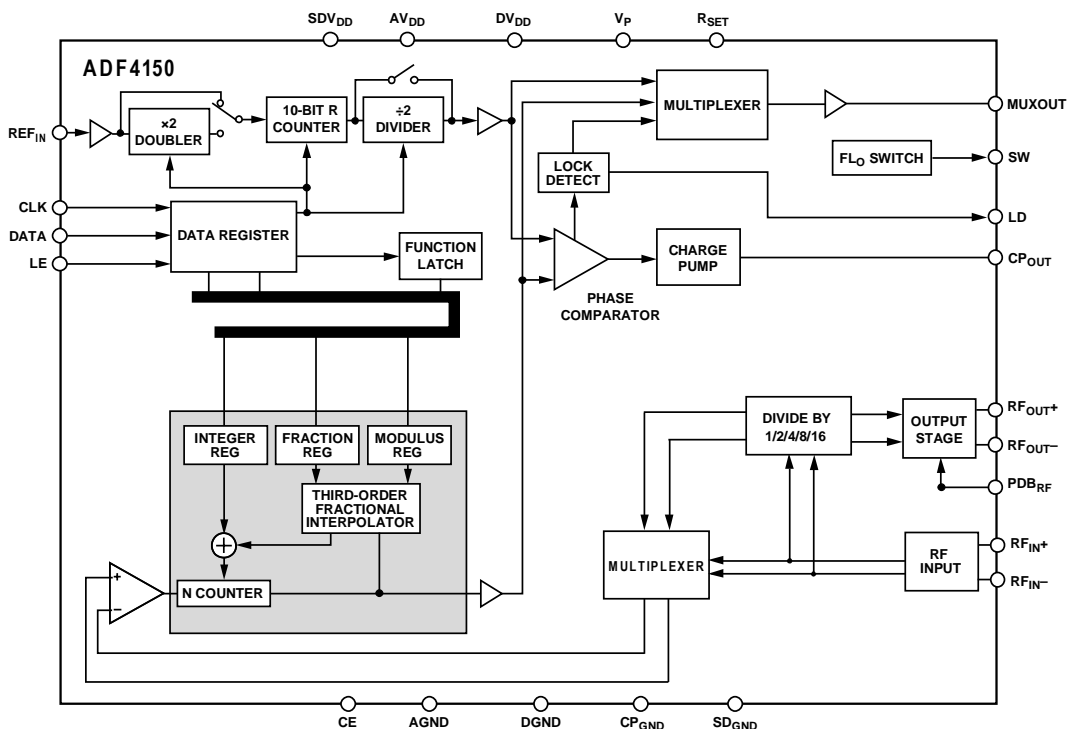

Figure 1.

Rev. Pr1

Information furnished by Analog Devices is believed to be accurate and reliable. However, no responsibility is assumed by Analog Devices for its use, nor for any infringements of patents or other rights of third parties that may result from its use. Specifications subject to change without notice. No license is granted by implication or otherwise under any patent or patent rights of Analog Devices. Trademarks and registered trademarks are the property of their respective owners.

One Technology Way, P.O. Box 9106, Norwood, MA 02062-9106, U.S.A.
Tel: 781.329.4700
Fax: 781.461.3113
www.analog.com
©2009 Analog Devices, Inc. All rights reserved.

TABLE OF CONTENTS

Features	1	Register 2	16
Applications.....	1	Register 3	17
General Description	1	Register 4	18
Functional Block Diagram	1	Register 5	18
Specifications.....	3	Initialization Sequence	18
Timing Characteristics.....	5	RF Synthesizer— A Worked Example	19
Absolute Maximum Ratings.....	6	Modulus.....	19
Transistor Count.....	6	Reference Doubler and Reference Divider	19
ESD Caution.....	6	12-Bit Programmable Modulus.....	19
Pin Configuration and Function Descriptions.....	7	Cycle Slip Reduction for Faster Lock Times.....	20
Typical Performance Characteristics	9	Spurious Optimization and Fast lock	20
Circuit Description.....	10	Fast-Lock Timer and Register Sequences	20
Reference Input Section.....	10	Fast Lock—An Example	20
RF N Divider.....	10	Fast Lock—Loop Filter Topology.....	20
INT, FRAC, MOD and R Counter Relationship	10	Spur Mechanisms	21
INT N MODE	10	Spur Consistency and Fractional Spur Optimization	21
R Counter	10	PHASE Resync.....	21
Phase Frequency Detector (PFD) and Charge Pump.....	10	Applications Information	23
MUXOUT and LOCK Detect.....	11	Direct Conversion Modulator	23
Input Shift Registers.....	11	Interfacing.....	24
Program Modes	11	PCB Design Guidelines for Chip Scale Package	24
Output Stage.....	11	Output Matching.....	25
Register Maps.....	12	Outline Dimensions	26
Register 0	16	Ordering Guide	26
Register 1	16		

SPECIFICATIONS

$AV_{DD} = DV_{DD} = SD_{VDD} = 3.3 \text{ V} \pm 10\%$; $V_P = AV_{DD}$ to 5.5 V ; $AGND = DGND = 0 \text{ V}$; $T_A = T_{MIN}$ to T_{MAX} , unless otherwise noted. Operating temperature range is -40°C to $+85^\circ\text{C}$.

Table 1.

Parameter	B Version	Unit	Conditions/Comments
REF_{IN} CHARACTERISTICS			
Input Frequency	10 to 250	MHz min to MHz max	For $f < 10 \text{ MHz}$ ensure slew rate $> 21 \text{ V}/\mu\text{s}$ Biased at $AV_{DD}/2^1$
Input Sensitivity	0.7 to AV_{DD}	V p-p min to V p-p max	
Input Capacitance	5.0	pF max	
Input Current	± 60	μA max	
RF INPUT CHARACTERISTICS			
RF Input Frequency (RF _{IN})	0.5/4.0 4.0/6.0	GHz min/max GHz min/max	-10 dBm/0 dBm minimum/maximum -5 dBm/0 dBm minimum/maximum For lower frequencies, ensure slew rate $> 400 \text{ V}/\mu\text{s}$
PHASE DETECTOR			
Phase Detector Frequency ²	32	MHz max	
CHARGE PUMP			
I _{CP} Sink/Source			With R _{SET} = 5.1 k Ω
High Value	5	mA typ	$0.5 \text{ V} \leq V_{CP} \leq V_P - 0.5 \text{ V}$ $0.5 \text{ V} \leq V_{CP} \leq V_P - 0.5 \text{ V}$ $V_{CP} = 2.0 \text{ V}$
Low Value	0.312	mA typ	
R _{SET} Range	2.7 to 10	k Ω min to k Ω max	
Sink and Source Current Matching	2	% typ	
I _{CP} vs. V _{CP}	1.5	% typ	
I _{CP} vs. Temperature	2	% typ	
LOGIC INPUTS			
Input High Voltage, V _{INH}	1.5	V min	
Input Low Voltage, V _{INL}	0.6	V max	
Input Current, I _{INH} /I _{INL}	± 1	μA max	
Input Capacitance, C _{IN}	3.0	pF max	
LOGIC OUTPUTS			
Output High Voltage, V _{OH}	$DV_{DD} - 0.4$	V min	CMOS output chosen I _{OL} = 500 μA
Output High Current, I _{OH}	500	μA max	
Output Low Voltage, V _O	0.4	V max	
POWER SUPPLIES			
AV _{DD}	3.0 to 3.6	V min to V max	Each output divide by two consumes 6 mA RF output stage is programmable
DV _{DD} , SD _{VDD} , V _P	AV _{DD} AV _{DD} /5.5	V min/V max	
DI _{DD} + AI _{DD} ³	25	mA typ	
Output Dividers	6-24	mA typ	
I _{RFOUT} ³	32	mA typ	
Low Power Sleep Mode	7	μA typ	
RF OUTPUT CHARACTERISTICS			
Minimum output frequency using RF output dividers	31.25	MHz	500 MHz VCO input and divide by 16 selected
Maximum RF _{IN} frequency using RF output dividers	3500	MHz	
Harmonic Content (Second)	-19	dBc typ	Fundamental VCO output
Harmonic Content (Third)	-13	dBc typ	
Harmonic Content (Second)	-20	dBc typ	Divided VCO output
Harmonic Content (Third)	-10	dBc typ	
Output Power ⁴	-4 to +5	dBm typ min to dBm typ max	Programmable in 3 dB steps
Output Power Variation	± 1	dB typ	

Parameter	B Version	Unit	Conditions/Comments
NOISE CHARACTERISTICS			
Normalized In-Band Phase Noise Floor ⁵	-219	dBc/Hz typ	Anti-backlash pulse width set to 6 ns.
Normalized In-Band Phase Noise Floor ⁶	-222	dBc/Hz typ	Anti-backlash pulse width set to 3 ns.
Spurious Signals Due to PFD Frequency	-70	dBc typ	
Level of Signal With RF Mute Enabled	-40	dBm typ	

¹ AC coupling ensures AV_{DD}/2 bias.

² Guaranteed by design. Sample tested to ensure compliance.

³ T_A = 25°C; AV_{DD} = DV_{DD} = 3.3 V; prescaler = 8/9; f_{REFIN} = 100 MHz; f_{PFD} = 25 MHz; f_{RF} = 2.5 GHz.

⁴ Using 50 Ω resistors to V_{VCO}, into a 50 Ω load.

⁵ This figure can be used to calculate phase noise for any application. To calculate in-band phase noise performance as seen at the VCO output use the following formula: -213 + 10log(f_{PFD}) + 20 logN. The value given is the lowest noise mode. f_{REFIN} = 100 MHz; f_{PFD} = 25 MHz; offset frequency = 50 kHz; VCO frequency = 1850.1 MHz. N = 74; loop BW = 500 kHz, I_{CP} = 2.5 mA; low noise mode. The noise was measured with an EVAL-ADF4150EB1Z and the Agilent E5052A signal source analyzer.

⁶ This figure can be used to calculate phase noise for any application. To calculate in-band phase noise performance as seen at the VCO output use the following formula: -213 + 10log(f_{PFD}) + 20 logN. The value given is the lowest noise mode. f_{REFIN} = 100 MHz; f_{PFD} = 25 MHz; offset frequency = 50 kHz; VCO frequency = 1850 MHz. N = 74; loop BW = 500 kHz, I_{CP} = 2.5 mA; low noise mode. The noise was measured with an EVAL-ADF4150EB1Z and the Agilent E5052A signal source analyzer.

TIMING CHARACTERISTICS

$AV_{DD} = DV_{DD} = SD_{VDD} = 3.3\text{ V} \pm 10\%$; $V_P = AV_{DD}$ to 5.5 V ; $AGND = DGND = 0\text{ V}$; $T_A = T_{MIN}$ to T_{MAX} , unless otherwise noted. Operating temperature range is -40°C to $+85^\circ\text{C}$.

Table 2.

Parameter	Limit (B Version)	Unit	Test Conditions/Comments
t_1	20	ns min	LE setup time
t_2	10	ns min	DATA to CLOCK setup time
t_3	10	ns min	DATA to CLOCK hold time
t_4	25	ns min	CLOCK high duration
t_5	25	ns min	CLOCK low duration
t_6	10	ns min	CLOCK to LE setup time
t_7	20	ns min	LE pulse width

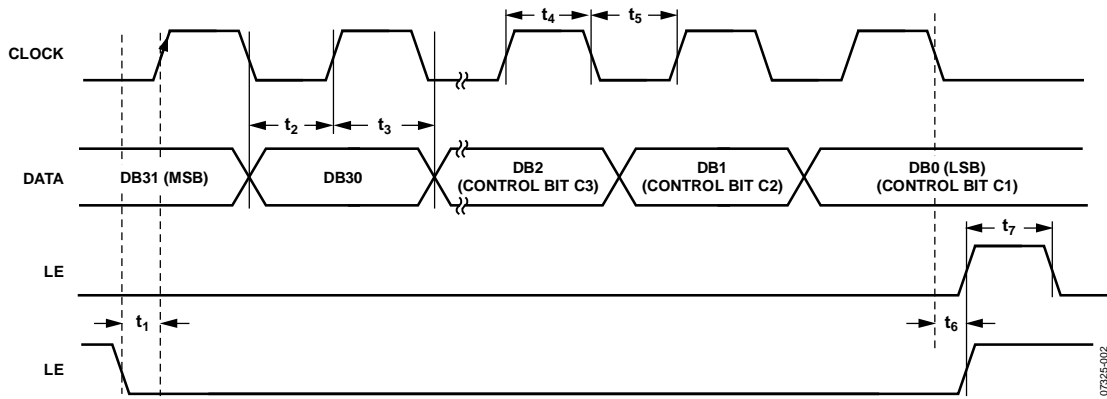

Figure 2. Timing Diagram

07325-002

ABSOLUTE MAXIMUM RATINGS

$T_A = 25^\circ\text{C}$, unless otherwise noted.

Table 3.

Parameter	Rating
AV_{DD} to GND ¹	-0.3 V to +3.9 V
AV_{DD} to DV_{DD}	-0.3 V to +0.3 V
V_P to AV_{DD}	-0.3 V to +5.8 V
Digital I/O Voltage to GND	-0.3 V to $V_{DD} + 0.3$ V
Analog I/O Voltage to GND	-0.3 V to $V_{DD} + 0.3$ V
REF_{IN} to GND	-0.3 V to $V_{DD} + 0.3$ V
Operating Temperature Range	-40°C to +85°C
Storage Temperature Range	-65°C to +125°C
Maximum Junction Temperature	150°C
LFCSP θ_{JA} Thermal Impedance (Paddle-Soldered)	27.3°C/W
Reflow Soldering	
Peak Temperature	260°C
Time at Peak Temperature	40 sec

¹ GND = AGND = DGND = 0 V

Stresses above those listed under Absolute Maximum Ratings may cause permanent damage to the device. This is a stress rating only; functional operation of the device at these or any other conditions above those indicated in the operational section of this specification is not implied. Exposure to absolute maximum rating conditions for extended periods may affect device reliability.

TRANSISTOR COUNT

23380 (CMOS) and 809 (bipolar)

ESD CAUTION



ESD (electrostatic discharge) sensitive device.

Charged devices and circuit boards can discharge without detection. Although this product features patented or proprietary protection circuitry, damage may occur on devices subjected to high energy ESD. Therefore, proper ESD precautions should be taken to avoid performance degradation or loss of functionality.

PIN CONFIGURATION AND FUNCTION DESCRIPTIONS

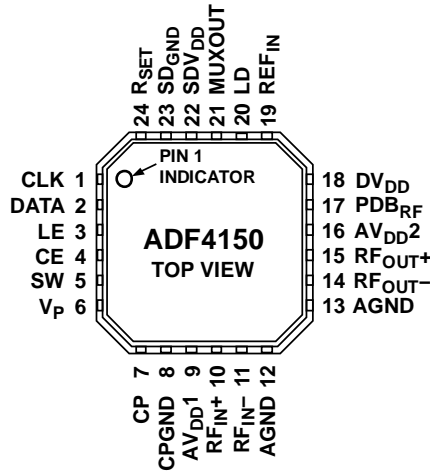

Figure 3. Pin Configuration, 24 lead 4mm x 4 mm

Table 4. Pin Function Descriptions

Pin No.	Mnemonic	Function
1	CLK	Serial Clock Input. Data is clocked into the 32-bit shift register on the CLK rising edge. This input is a high impedance CMOS input.
2	DATA	Serial Data Input. The serial data is loaded MSB first with the three LSBs as the control bits. This input is a high impedance CMOS input.
3	LE	Load Enable, CMOS Input. When LE goes high, the data stored in the shift register is loaded into the register that is selected by the three LSBs.
4	CE	Chip Enable. A logic low on this pin powers down the device and puts the charge pump into three-state mode. Taking the pin high powers up the device depending on the status of the power-down bits.
5	SW	Fastlock Switch. A connection should be made from the loop filter to this pin when using the fastlock mode.
6	V _P	Charge Pump Power Supply. This should be greater than or equal to AV _{DD} . In systems where AV _{DD} is 3 V, it can be set to 5.5 V and used to drive a VCO with a tuning range of up to 5.5 V.
7	CP	Charge Pump Output. When enabled, this provides ±I _{CP} to the external loop filter. The output of the loop filter is connected to V _{TUNE} to drive the external VCO.
8	CP _{GND}	Charge Pump Ground. This is the ground return pin for CP _{OUT} .
9	AV _{DD1}	Analog Power Supply. This ranges from 3.0 V to 3.6 V. Decoupling capacitors to the analog ground plane are to be placed as close as possible to this pin. AV _{DD1} must have the same value as DV _{DD} .
10	RF _{IN+}	Input to the RF Input. This small signal input is ac-coupled to the external VCO.
11	RF _{IN-}	Complementary Input to the RF Input. This point must be decoupled to the ground plane with a small bypass capacitor, typically 100 pF.
12,13	AGND	Analog Ground. This is a ground return pin for AV _{DD1} and AV _{DD2} .
14	RF _{OUT-}	Complementary RF Output. The output level is programmable. The VCO fundamental output or a divided down version is available.
15	RF _{OUT+}	RF Output. The output level is programmable. The VCO fundamental output or a divided down version is available.
16	AV _{DD2}	Analog Power Supply. This ranges from 3.0 V to 3.6 V. Decoupling capacitors to the analog ground plane are to be placed as close as possible to this pin. AV _{DD2} must have the same value as DV _{DD} .
17	PDB _{RF}	RF Power-Down. A logic low on this pin mutes the RF outputs. This function is also software controllable.
18	DV _{DD}	Digital Power Supply. Should be the same voltage as AV _{DD} . Decoupling capacitors to the ground plane should be placed as close as possible to this pin.
19	REF _{IN}	Reference Input. This is a CMOS input with a nominal threshold of V _{DD} /2 and a dc equivalent input resistance of 100 kΩ. This input can be driven from a TTL or CMOS crystal oscillator, or it can be ac-coupled.
20	LD	Lock Detect output pin. This pin outputs a logic high to indicate PLL lock. A logic low output indicates loss of PLL lock.
21	MUXOUT	Multiplexer Output. This multiplexer output allows either the lock detect, the scaled RF, or the scaled reference frequency to be accessed externally.

Pin No.	Mnemonic	Function
22	SDV _{DD}	Power Supply Pin for the Digital Σ - Δ Modulator. Should be the same voltage as AV _{DD} . Decoupling capacitors to the ground plane are to be placed as close as possible to this pin.
23	SD _{GND}	Digital Σ - Δ Modulator Ground. Ground return path for the Σ - Δ Modulator.
24	R _{SET}	Connecting a resistor between this pin and GND sets the charge pump output current. The nominal voltage bias at the R _{SET} pin is 0.55 V. The relationship between I _{CP} and R _{SET} is $I_{CP} = \frac{25.5}{R_{SET}}$ where R _{SET} = 5.1 k Ω , I _{CP} = 5 mA.

TYPICAL PERFORMANCE CHARACTERISTICS

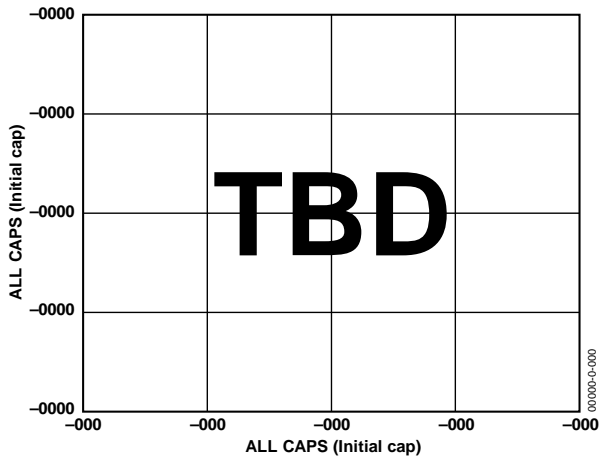

Figure 4

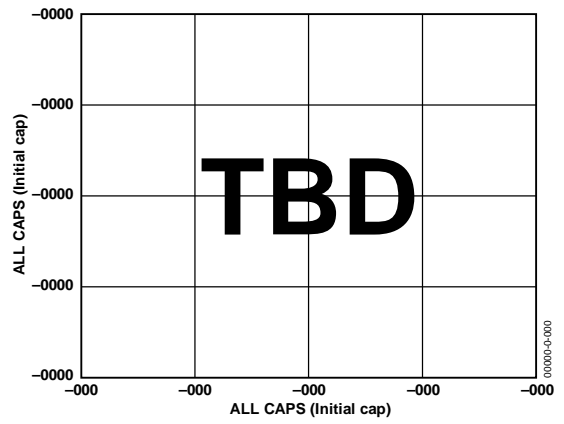

Figure 5.

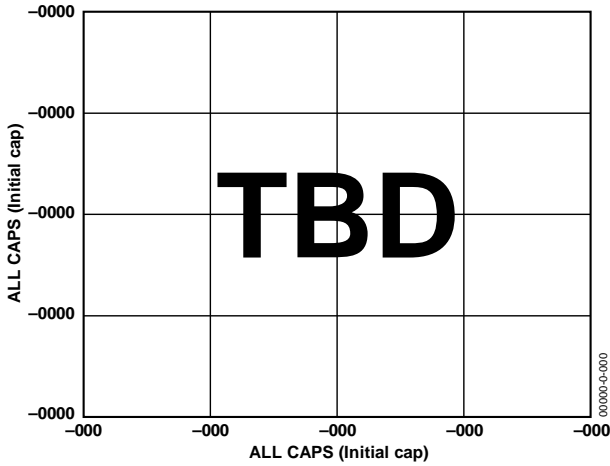

Figure 6.

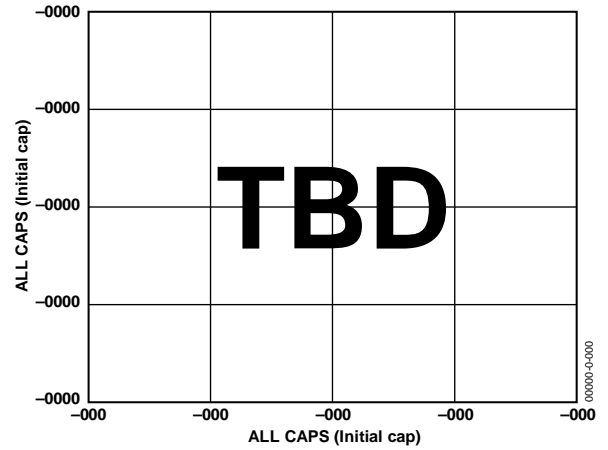

Figure 7.

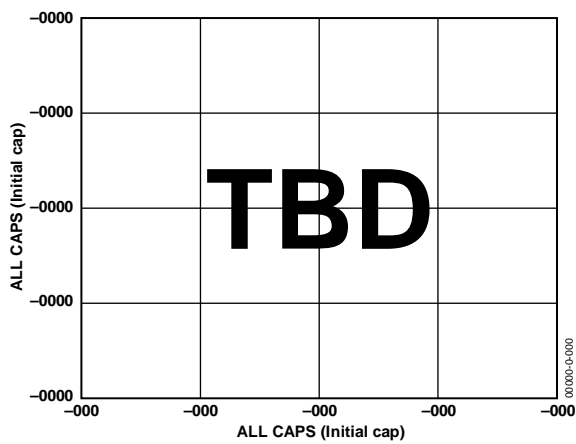

Figure 8.

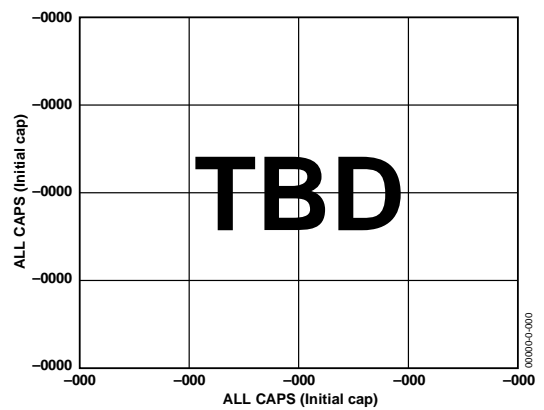

Figure 9.

CIRCUIT DESCRIPTION

REFERENCE INPUT SECTION

The reference input stage is shown in Figure 5. SW1 and SW2 are normally closed switches. SW3 is normally open. When power-down is initiated, SW3 is closed, and SW1 and SW2 are opened. This ensures that there is no loading of the REF_{IN} pin on power-down.

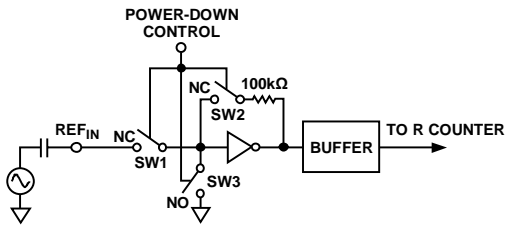

Figure 10. Reference Input Stage

RF N DIVIDER

The RF N divider allows a division ratio in the PLL feedback path. Division ratio is determined INT, FRAC and MOD values, which build up this divider.

INT, FRAC, MOD AND R COUNTER RELATIONSHIP

The INT, FRAC, and MOD values, in conjunction with the R counter, make it possible to generate output frequencies that are spaced by fractions of the PFD frequency. See the RF Synthesizer—A Worked Example section for more information. The RF VCO frequency (RF_{OUT}) equation is

$$f_{RFOUT} = f_{PFD} \times (INT + (FRAC/MOD)) \quad (1)$$

where RF_{OUT} is the output frequency of external voltage controlled oscillator (VCO).

$$f_{PFD} = REF_{IN} \times [(1 + D)/(R \times (1 + T))] \quad (2)$$

where

REF_{IN} is the reference input frequency.

D is the REF_{IN} doubler bit.

T is the REF_{IN} divide-by-2 bit (0 or 1).

R is the preset divide ratio of the binary 10-bit programmable reference counter (1 to 1023).

INT is the preset divide ratio of the binary 16-bit counter (23 to 65535 for 4/5 prescaler, 75 to 65535 for 8/9 prescaler).

MOD is the preset fractional modulus (2 to 4095).

FRAC is the numerator of the fractional division (0 to MOD - 1).

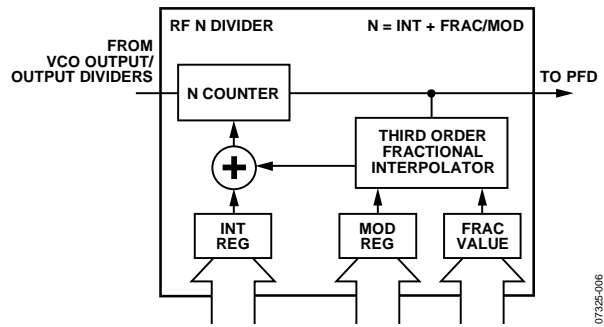

Figure 11. RF INT Divider

INT N MODE

If the FRAC = 0 and DB8 in Register 2 (LDF) is set to 1, the synthesizer operates in integer-N mode. The DB8 in Register 2 (LDF) should be set to 1 to get integer-N digital lock detect.

R COUNTER

The 10-bit R counter allows the input reference frequency (REF_{IN}) to be divided down to produce the reference clock to the PFD. Division ratios from 1 to 1023 are allowed.

PHASE FREQUENCY DETECTOR (PFD) AND CHARGE PUMP

The Phase Frequency Detector (PFD) takes inputs from the R counter and N counter and produces an output proportional to the phase and frequency difference between them. Figure 12 is a simplified schematic of the phase frequency detector. The PFD includes a programmable delay element that sets the width of the anti-backlash pulse, which can be either 6 ns (default) or 3 ns (for integer-N mode). This pulse ensures there is no dead zone in the PFD transfer function, and gives a consistent reference spur level.

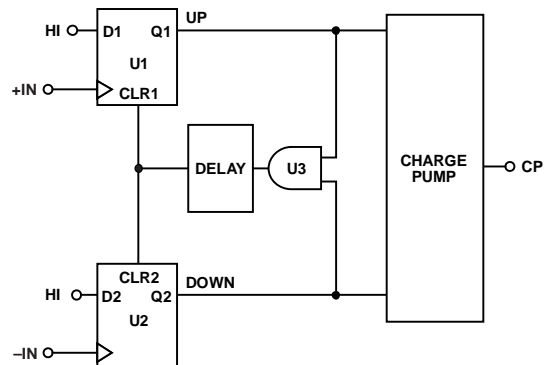

Figure 12. PFD Simplified Schematic

MUXOUT AND LOCK DETECT

The output multiplexer on the ADF4150 allows the user to access various internal points on the chip. The state of MUXOUT is controlled by M3, M2, and M1 (for details, see Figure 18). Figure 13 shows the MUXOUT section in block diagram form.

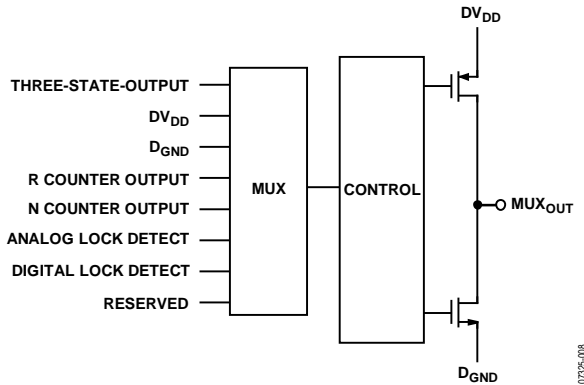

Figure 13. MUXOUT Schematic

INPUT SHIFT REGISTERS

The ADF4150 digital section includes a 10-bit RF R counter, a 16-bit RF N counter, a 12-bit FRAC counter, and a 12-bit modulus counter. Data is clocked into the 32-bit shift register on each rising edge of CLK. The data is clocked in MSB first. Data is transferred from the shift register to one of six latches on the rising edge of LE. The destination latch is determined by the state of the three control bits (C3, C2 and C1) in the shift register. These are the 3 LSBs, DB2, DB1, and DB0, as shown in Figure 2. The truth table for these bits is shown in Table 5. Figure 19 shows a summary of how the latches are programmed.

PROGRAM MODES

Table 5 and Figure 11 through Figure 21 show how the program modes are to be set up in the ADF4150.

A number of settings in the ADF4150 are double buffered. These include the modulus value, phase value, R counter value, reference doubler, reference divide-by-2, and current setting. This means that two events have to occur before the part uses a new value of any of the double buffered settings. First, the new value is latched into the device by writing to the appropriate register. Second, a new write must be performed on Register R0. For example, any time the modulus value is updated, Register 0 (R0) must be written to, to ensure the modulus value is loaded correctly. Divider select in Register 4 (R4) is also double buffered, but only if DB13 of Register 2 (R2) is high.

Table 5. C3, C2 and C1 Truth Table

Control Bits			Register
C3	C2	C1	
0	0	0	Register 0 (R0)
0	0	1	Register 1 (R1)
0	1	0	Register 2 (R2)
0	1	1	Register 3 (R3)
1	0	0	Register 4 (R4)
1	0	1	Register 5 (R5)

OUTPUT STAGE

The RF_{OUT+} and RF_{OUT-} pins of the ADF4150 family are connected to the collectors of an NPN differential pair driven by buffered outputs of the VCO, as shown in Figure 14. To allow the user to optimize the power dissipation vs. the output power requirements, the tail current of the differential pair is programmable by Bit D2 and Bit D1 in Register 4 (R4). Four current levels may be set. These levels give output power levels of -4 dBm, -1 dBm, +2 dBm, and +5 dBm, respectively, using a 50 Ω resistor to VDD and ac coupling into a 50 Ω load. Alternatively, both outputs can be combined in a 1 + 1:1 transformer or a 180° microstrip coupler (see Output Matching Section) If the outputs are used individually, the optimum output stage consists of a shunt inductor to VDD.

Another feature of the ADF4150 family is that the supply current to the RF output stage can be shut down until the part achieves lock as measured by the digital lock detect circuitry. This is enabled by the mute-till-lock detect (MTLD) bit in Register 4 (R4).

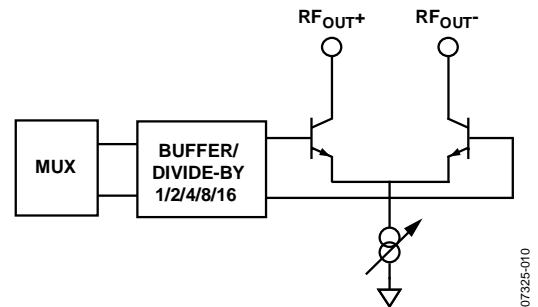

Figure 14. Output Stage

REGISTER MAPS

REGISTER 0

RESERVED																16-BIT INTEGER VALUE (INT)																12-BIT FRACTIONAL VALUE (FRAC)																CONTROL BITS		
DB31	DB30	DB29	DB28	DB27	DB26	DB25	DB24	DB23	DB22	DB21	DB20	DB19	DB18	DB17	DB16	DB15	DB14	DB13	DB12	DB11	DB10	DB9	DB8	DB7	DB6	DB5	DB4	DB3	DB2	DB1	DB0																			
0	N16	N15	N14	N13	N12	N11	N10	N9	N8	N7	N6	N5	N4	N3	N2	N1	F12	F11	F10	F9	F8	F7	F6	F5	F4	F3	F2	F1	C3(0)	C2(0)	C1(0)																			

REGISTER 1

RESERVED																PRESALER	12-BIT PHASE VALUE (PHASE)																12-BIT MODULUS VALUE (MOD)																CONTROL BITS		
DB31	DB30	DB29	DB28	DB27	DB26	DB25	DB24	DB23	DB22	DB21	DB20	DB19	DB18	DB17	DB16	DB15	DB14	DB13	DB12	DB11	DB10	DB9	DB8	DB7	DB6	DB5	DB4	DB3	DB2	DB1	DB0																				
0	0	0	0	P1	P12	P11	P10	P9	P8	P7	P6	P5	P4	P3	P2	P1	M12	M11	M10	M9	M8	M7	M6	M5	M4	M3	M2	M1	C3(0)	C2(0)	C1(1)																				

REGISTER 2

RESERVED																NOISE MODE		MUXOUT			REFERENCE DOUBLER DBR ¹		RDIV2 DBR ¹		10-BIT R COUNTER DBR ¹																DOUBLE BUFF		CURRENT SETTING DBR ¹			LDF		LDP		PD POLARITY		PD		CP THREE-STATE		COUNTER RESET		CONTROL BITS		
DB31	DB30	DB29	DB28	DB27	DB26	DB25	DB24	DB23	DB22	DB21	DB20	DB19	DB18	DB17	DB16	DB15	DB14	DB13	DB12	DB11	DB10	DB9	DB8	DB7	DB6	DB5	DB4	DB3	DB2	DB1	DB0																													
0	L2	L1	M3	M2	M1	RD2	RD1	R10	R9	R8	R7	R6	R5	R4	R3	R2	R1	D1	CP4	CP3	CP2	CP1	U6	U5	U4	U3	U2	U1	C3(0)	C2(1)	C1(0)																													

REGISTER 3

RESERVED																ABP		CHARGE CANCEL		RESERVED			CSR		RESERVED		CLK DIV MODE		12-BIT CLOCK DIVIDER VALUE																CONTROL BITS		
DB31	DB30	DB29	DB28	DB27	DB26	DB25	DB24	DB23	DB22	DB21	DB20	DB19	DB18	DB17	DB16	DB15	DB14	DB13	DB12	DB11	DB10	DB9	DB8	DB7	DB6	DB5	DB4	DB3	DB2	DB1	DB0																
0	0	0	0	0	0	0	0	0	F3	F2	V2	V1	F1	0	C2	C1	D12	D11	D10	D9	D8	D7	D6	D5	D4	D3	D2	D1	C3(0)	C2(1)	C1(1)																

REGISTER 4

RESERVED																FEEDBACK SELECT		DBB ² DIVIDER SELECT		RESERVED																MTLD		RESERVED			RF OUTPUT ENABLE		OUTPUT POWER		CONTROL BITS		
DB31	DB30	DB29	DB28	DB27	DB26	DB25	DB24	DB23	DB22	DB21	DB20	DB19	DB18	DB17	DB16	DB15	DB14	DB13	DB12	DB11	DB10	DB9	DB8	DB7	DB6	DB5	DB4	DB3	DB2	DB1	DB0																
0	0	0	0	0	0	0	0	D13	D12	D11	D10	0	0	0	0	0	0	0	0	0	0	D8	D7	D6	D5	D4	D3	D2	D1	C3(1)	C2(0)	C1(0)															

REGISTER 5

RESERVED																LD PIN MODE		RESERVED		RESERVED																CONTROL BITS		
DB31	DB30	DB29	DB28	DB27	DB26	DB25	DB24	DB23	DB22	DB21	DB20	DB19	DB18	DB17	DB16	DB15	DB14	DB13	DB12	DB11	DB10	DB9	DB8	DB7	DB6	DB5	DB4	DB3	DB2	DB1	DB0							
0	0	0	0	0	0	0	0	D15	D14	0	1	1	0	0	0	0	0	0	0	0	0	0	0	0	0	0	0	0	0	0	0	C3(1)	C2(0)	C1(1)				

¹DBR = DOUBLE BUFFERED REGISTER—BUFFERED BY THE WRITE TO REGISTER 0.
²DBB = DOUBLE BUFFERED BITS—BUFFERED BY THE WRITE TO REGISTER 0, IF AND ONLY IF DB13 OF REGISTER 2 IS HIGH.

Figure 15. Register Summary

RESERVED	16-BIT INTEGER VALUE (INT)																12-BIT FRACTIONAL VALUE (FRAC)												CONTROL BITS		
DB31	DB30	DB29	DB28	DB27	DB26	DB25	DB24	DB23	DB22	DB21	DB20	DB19	DB18	DB17	DB16	DB15	DB14	DB13	DB12	DB11	DB10	DB9	DB8	DB7	DB6	DB5	DB4	DB3	DB2	DB1	DB0
0	N16	N15	N14	N13	N12	N11	N10	N9	N8	N7	N6	N5	N4	N3	N2	N1	F12	F11	F10	F9	F8	F7	F6	F5	F4	F3	F2	F1	C3(0)	C2(0)	C1(0)

N16	N15	...	N5	N4	N3	N2	N1	INTEGER VALUE (INT)
0	0	...	0	0	0	0	0	NOT ALLOWED
0	0	...	0	0	0	0	1	NOT ALLOWED
0	0	...	0	0	0	1	0	NOT ALLOWED
.
0	0	...	1	0	1	1	0	NOT ALLOWED
0	0	...	1	0	1	1	1	23
0	0	...	1	1	0	0	0	24
.
1	1	...	1	1	1	0	1	65533
1	1	...	1	1	1	1	0	65534
1	1	...	1	1	1	1	1	65535

F12	F11	F2	F1	FRACTIONAL VALUE (FRAC)
0	0	0	0	0
0	0	0	1	1
0	0	1	0	2
0	0	1	1	3
.
.
.
1	1	0	0	4092
1	1	0	1	4093
1	1	1	0	4094
1	1	1	1	4095

INTmin = 75 with prescaler = 8/9

Figure 16. Register 0 (R0)

RESERVED				PRESCALER	12-BIT PHASE VALUE (PHASE)												12-BIT MODULUS VALUE (MOD)												CONTROL BITS		
DB31	DB30	DB29	DB28	DB27	DB26	DB25	DB24	DB23	DB22	DB21	DB20	DB19	DB18	DB17	DB16	DB15	DB14	DB13	DB12	DB11	DB10	DB9	DB8	DB7	DB6	DB5	DB4	DB3	DB2	DB1	DB0
0	0	0	0	P1	P12	P11	P10	P9	P8	P7	P6	P5	P4	P3	P2	P1	M12	M11	M10	M9	M8	M7	M6	M5	M4	M3	M2	M1	C3(0)	C2(0)	C1(1)

P1	PRESCALER
0	4/5
1	8/9

P12	P11	P2	P1	PHASE VALUE (PHASE)
0	0	0	0	0
0	0	0	1	1 (RECOMMENDED)
0	0	1	0	2
0	0	1	1	3
.
.
.
1	1	0	0	4092
1	1	0	1	4093
1	1	1	0	4094
1	1	1	1	4095

M12	M11	M2	M1	INTERPOLATOR MODULUS (MOD)
0	0	1	0	2
0	0	1	1	3
.
.
.
1	1	0	0	4092
1	1	0	1	4093
1	1	1	0	4094
1	1	1	1	4095

Figure 17. Register 1 (R1)

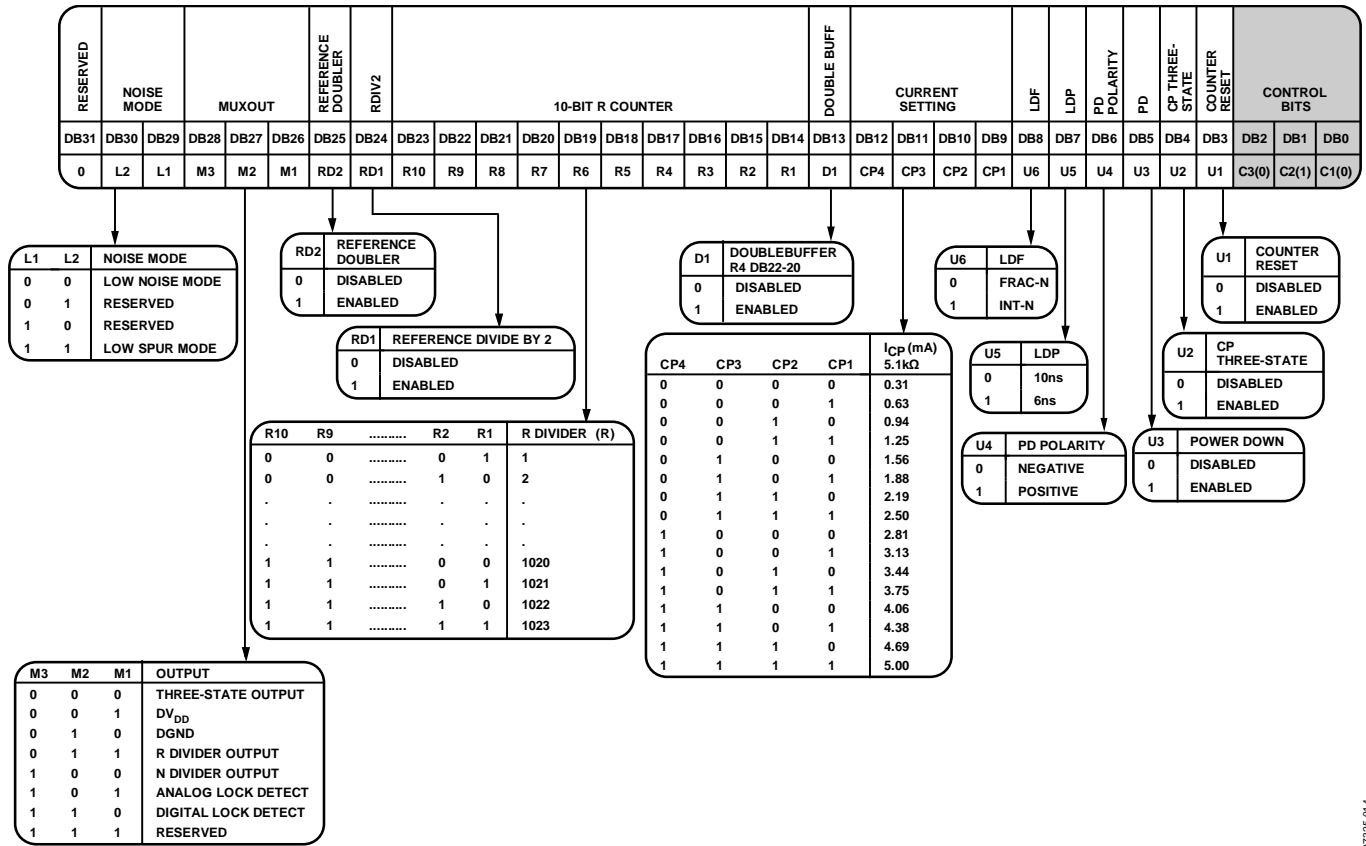

Figure 18. Register 2 (R2)

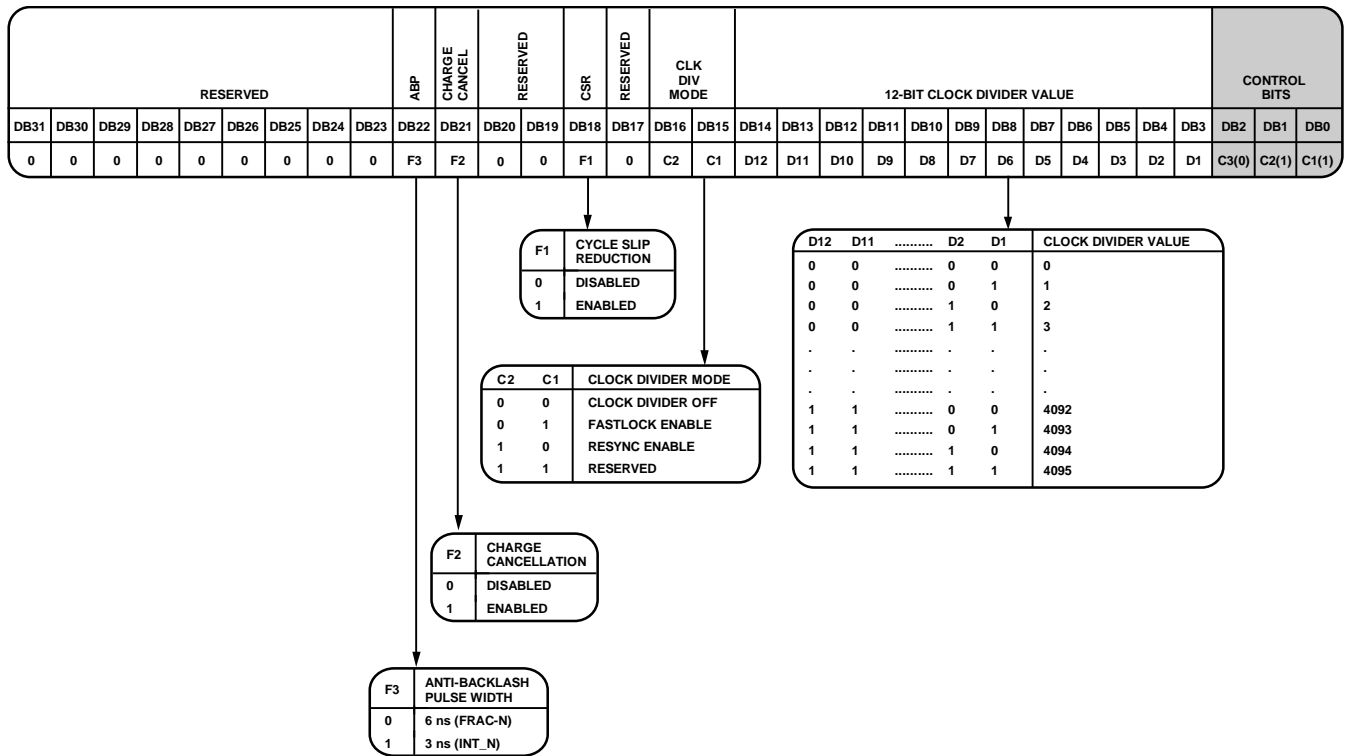

Figure 19. Register 3 (R3)

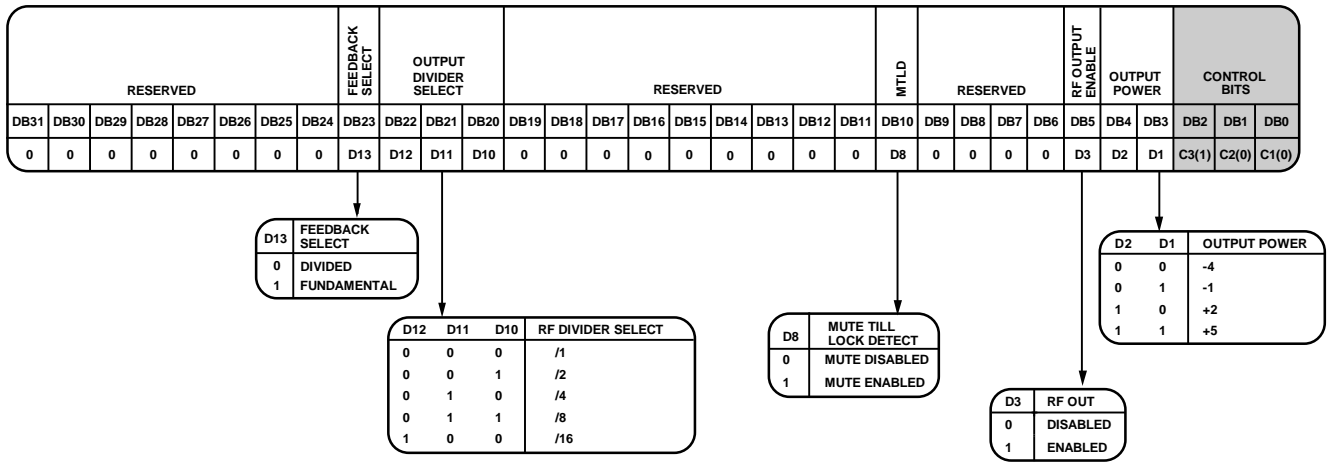

Figure 20. Register 4 (R4)

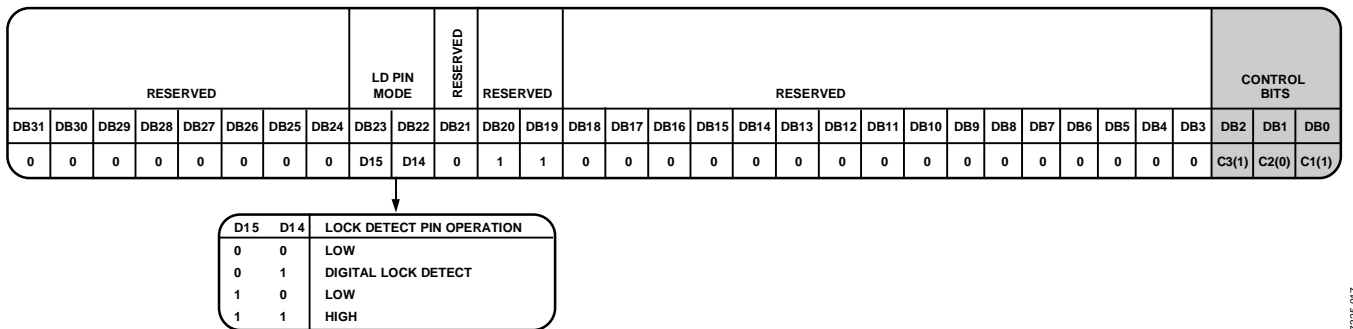

Figure 21. Register 5 (R5)

07325-016

07325-017

REGISTER 0**Control Bits**

With Bits [C3:C1] set to 0, 0, 0, Register 0 is programmed. Figure 16 shows the input data format for programming this register.

16-Bit INT Value

These sixteen bits set the INT value, which determines the integer part of the feedback division factor. It is used in Equation 1 (see the INT, FRAC, MOD and R Counter Relationship section). All integer values from 23 to 65,535 are allowed for 4/5 prescaler. For 8/9 prescaler, the minimum integer value is 75.

12-Bit FRAC Value

The 12 FRAC bits set the numerator of the fraction that is input to the Σ - Δ modulator. This, along with INT, specifies the new frequency channel that the synthesizer locks to, as shown in the RF Synthesizer—A Worked Example section. FRAC values from 0 to MOD – 1 cover channels over a frequency range equal to the PFD reference frequency.

REGISTER 1**Control bits**

With Bits [C3:C1] set to 0, 0, 1, Register 1 is programmed. Figure 17 shows the input data format for programming this register.

Prescaler Value

The dual modulus prescaler ($P/P + 1$), along with the INT, FRAC, and MOD counters, determines the overall division ratio from the VCO output to the PFD input.

Operating at CML levels, it takes the clock from the VCO output and divides it down for the counters. It is based on a synchronous 4/5 core. When set to 4/5, the maximum RF frequency allowed is 3 GHz. Therefore, when operating the ADF4150 above 3 GHz, this must be set to 8/9. The prescaler limits the INT value, where:

$$P = 4/5, N_{MIN} = 23$$

$$P = 8/9, N_{MIN} = 75$$

In the ADF4150 P1 in Register 1 sets the prescaler values.

12-Bit PHASE Value

These bits control what is loaded as the PHASE word. The word must be less than the MOD value programmed in Register 1. The word is used to program the RF output phase from 0° to 360° with a resolution of 360°/MOD. See the PHASE Resync section for more information. In most applications, the phase relationship between the RF signal and the reference is not important. In such applications, the PHASE value can be used to optimize the fractional and subfractional spur levels. See the Spur Consistency and Fractional Spur Optimization section for more information.

If neither the PHASE resync nor the spurious optimization functions are being used, it is recommended the PHASE word be set to 1.

12-Bit Interpolator MOD Value

This programmable register sets the fractional modulus. This is the ratio of the PFD frequency to the channel step resolution on the RF output. Please refer to the RF Synthesizer—A Worked Example section for more information.

REGISTER 2**Control Bits**

With Bits [C3:C1] set to 0, 1, 0, Register 2 is programmed. Figure 18 shows the input data format for programming this register.

Noise and Spur Modes

The noise modes on the ADF4150 are controlled by DB30 and DB29 in Register 2 (see Figure 18). The noise modes allow the user to optimize a design either for improved spurious performance or for improved phase noise performance.

When the lowest spur setting is chosen, dither is enabled. This randomizes the fractional quantization noise so it resembles white noise rather than spurious noise. As a result, the part is optimized for improved spurious performance. This operation would normally be used when the PLL closed-loop bandwidth is wide, for fast-locking applications. (Wide loop bandwidth is seen as a loop bandwidth greater than 1/10 of the RF_{OUT} channel step resolution (f_{RES})). A wide loop filter does not attenuate the spurs to the same level as a narrow loop bandwidth.

For best noise performance, use the lowest noise setting option. As well as disabling the dither, it also ensures that the charge pump is operating in an optimum region for noise performance. This setting is extremely useful where a narrow loop filter bandwidth is available. The synthesizer ensures extremely low noise and the filter attenuates the spurs. The typical performance characteristics give the user an idea of the trade-off in a typical WCDMA setup for the different noise and spur settings.

MUXOUT

The on-chip multiplexer is controlled by Bits [DB28:DB26] (see Figure 18).

Reference Doubler

Setting DB25 to 0 feeds the REF_{IN} signal directly to the 10-bit R counter, disabling the doubler. Setting this bit to 1 multiplies the REF_{IN} frequency by a factor of 2 before feeding into the 10-bit R counter. When the doubler is disabled, the REF_{IN} falling edge is the active edge at the PFD input to the fractional synthesizer. When the doubler is enabled, both the rising and falling edges of REF_{IN} become active edges at the PFD input.

When the doubler is enabled and the lowest spur mode is chosen, the in-band phase noise performance is sensitive to the REF_{IN} duty cycle. The phase noise degradation can be as much as 5 dB for the REF_{IN} duty cycles outside a 45% to 55% range. The phase noise is insensitive to the REF_{IN} duty cycle in the lowest noise mode. The phase noise is insensitive to REF_{IN} duty cycle when the doubler is disabled.

The maximum allowable REF_{IN} frequency when the doubler is enabled is 30 MHz.

RDIV2

Setting the DB24 bit to 1 inserts a divide-by-2 toggle flip-flop between the R counter and PFD, which extends the maximum REF_{IN} input rate. This function allows a 50% duty cycle signal to appear at the PFD input, which is necessary for cycle slip reduction.

10-Bit R Counter

The 10-bit R counter allows the input reference frequency (REF_{IN}) to be divided down to produce the reference clock to the PFD. Division ratios from 1 to 1023 are allowed.

Double Buffer

DB13 enables or disables double buffering of Bits [DB22:DB20] in Register 4. The Divider Select section explains how double buffering works.

Charge Pump Current Setting

Bits [DB12:DB09] set the charge pump current setting. This should be set to the charge pump current that the loop filter is designed with (see Figure 18).

LDF

Setting DB8 to 1 enables integer-N digital lock detect, when FRAC part of the divider is zero; setting DB8 to 0 enables fractional-N digital lock detect.

Lock Detect Precision (LDP)

When DB7 is set to 0, 40 consecutive PFD cycles of 10 ns must occur before digital lock detect is set. When this bit is programmed to 1, 40 consecutive reference cycles of 6 ns must occur before digital lock detect is set. When DB8 is set to 0, the fractional-N digital lock detect is activated. When DB8 is set to 1, the integer-N digital lock detect is activated. In this case, setting DB7 to 0 causes three consecutive cycles of 15 ns to occur before digital lock detect is set. When this bit is set to 1, five consecutive cycles of 15 ns must occur.

Phase Detector Polarity

DB6 sets the phase detector polarity. When a passive loop filter, or non-inverting active loop filter is used, this should be set to 1. If an active filter with an inverting characteristic is used, it should be set to 0.

Power-Down

DB5 provides the programmable power-down mode. Setting this bit to 1 performs a power-down. Setting this bit to 0 returns the synthesizer to normal operation. When in software power-down mode, the part retains all information in its registers. Only if the supply voltages are removed are the register contents lost.

When a power-down is activated, the following events occur:

- The synthesizer counters are forced to their load state conditions.
- The charge pump is forced into three-state mode.
- The digital lock detect circuitry is reset.
- The RF_{OUT} buffers are disabled.
- The input register remains active and capable of loading and latching data.

Charge Pump Three-State

DB4 puts the charge pump into three-state mode when programmed to 1. It should be set to 0 for normal operation.

Counter Reset

DB3 is the R counter and N counter reset bit for the ADF4150. When this is 1, the RF synthesizer N counter and R counter are held in reset. For normal operation, this bit should be set to 0.

REGISTER 3**Control Bits**

With Bits [C3:C1] set to 0, 1, 1, Register 3 is programmed. Figure 19 shows the input data format for programming this register.

Anti-backlash pulse width

Setting DB22 bit to 0 sets the PFD anti-backlash pulse width to 6 ns. This is the recommended mode for fractional-N use. Setting this bit to 1, the 3 ns pulse-width is used and will result in a phase noise and spur improvement in integer-N operation. For fractional-N mode it is not recommended to use this smaller setting.

Charge cancellation mode pulse width

Setting this bit to 1 enables charge pump charge cancellation. This has the effect of reducing PFD spurs in Integer-N mode. In fractional-N mode this should not be used and the relevant result in a phase noise and spur improvement. For fractional-N mode it is not recommended to use this smaller setting.

CSR Enable

Setting this bit to 1 enables cycle slip reduction. This is a method for improving lock times. Note that the signal at the phase frequency detector (PFD) must have a 50% duty cycle for cycle slip reduction to work. The charge pump current setting must also be set to a minimum. See the Cycle Slip Reduction for Faster Lock Time section for more information.

Clock Divider Mode

Bits [DB16:DB15] must be set to 1, 0 to activate PHASE resync or 0, 1 to activate fast lock. Setting Bits [DB16:DB15] to 0, 0 disables the clock divider. See Figure 19.

12-Bit Clock Divider Value

The 12-bit clock divider value sets the timeout counter for activation of PHASE resync. See the PHASE Resync section for more information. It also sets the timeout counter for fast lock. See the Fast-Lock Timer and Register Sequences section for more information.

REGISTER 4**Control Bits**

With Bits [C3: C1] set to 1, 0, 0, Register 4 is programmed. Figure 20 shows the input data format for programming this register.

Feedback Select

DB23 selects the feedback from VCO output to the N-counter. When set to 1, the signal is taken from the VCO directly. When set to 0, it is taken from the output of the Output dividers. The dividers enable covering of the wide frequency band (137.5 MHz – 4.4 GHz). When the divider is enabled and the feedback signal is taken from the output, the RF output signals of two separately configured PLLs are in phase. This is useful in some applications where the positive interference of signals is required to increase the power.

Divider Select

Bits [DB22:DB20] select the value of the output divider (see Figure 20).

Mute-till-Lock Detect

If DB10 is set to 1, the supply current to the RF output stage is shut down until the part achieves lock as measured by the digital lock detect circuitry.

RF Output Enable

DB5 enables or disables primary RF output, depending on the chosen value.

Output Power

DB4 and DB3 set the value of the primary RF output power level (see Figure 20).

REGISTER 5**Control Bits**

With Bits [C3:C1] set to 1, 0, 1, Register 5 is programmed. Figure 21 shows the input data form for programming this register.

Lock Detect PIN Operation

Bits [DB32:DB22] set the operation of the lock detect PIN (see Figure 21).

INITIALIZATION SEQUENCE

The following sequence of registers is the correct sequence for initial power up of the ADF4150 after the correct application of voltages to the supply pins:

- Register 5
- Register 4
- Register 3
- Register 2
- Register 1
- Register 0

RF SYNTHESIZER— A WORKED EXAMPLE

The following is an example how to program the ADF4150 synthesizer:

$$RF_{OUT} = [INT + (FRAC/MOD)] \times [f_{PFD}] / RFDivider \quad (3)$$

where:

RF_{OUT} is the RF frequency output.

INT is the integer division factor.

$FRAC$ is the fractionality.

MOD is the modulus.

RF Divider is the output divider that divides down the VCO frequency.

$$f_{PFD} = REF_{IN} \times [(1 + D)/(R \times (1+T))] \quad (4)$$

where:

REF_{IN} is the reference frequency input.

D is the RF REF_{IN} doubler bit.

T is the reference divide-by-2 bit (0 or 1).

R is the RF reference division factor.

For example, in a UMTS system, where 2112.6 MHz RF frequency output (RF_{OUT}) is required, a 10 MHz reference frequency input (REF_{IN}) is available, and a 200 kHz channel resolution (f_{RESOUT}) is required, on the RF output. A 2.1 GHz VCO would be suitable, but a 4.2 GHz VCO would be suitable also. In the second case, the RF divider of 2 should be used (VCO frequency = 4225.2 MHz, $RF_{OUT} = VCO \text{ frequency} / RF \text{ Divider} = 4225.2 \text{ MHz} / 2 = 2112.6 \text{ MHz}$).

It is also important where the loop is closed. In this example the loop is closed as depicted in Figure 18 (from Out Divider).

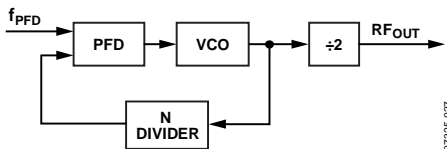

Figure 22. Loop closed before output divider

200 kHz channel resolution (f_{RESOUT}) is required at the output of the RF divider. Therefore, channel resolution at the output of the VCO (f_{RES}) is to be twice the f_{RESOUT} , that is 400kHz.

$$MOD = REF_{IN} / f_{RES}$$

$$MOD = 10 \text{ MHz} / 400 \text{ kHz} = 25$$

From Equation 4

$$f_{PFD} = [10 \text{ MHz} \times (1 + 0) / 1] = 10 \text{ MHz} \quad (5)$$

$$2112.6 \text{ MHz} = 10 \text{ MHz} \times (INT + FRAC/25) / 2 \quad (6)$$

where:

$INT = 422$

$FRAC = 13$

MODULUS

The choice of modulus (MOD) depends on the reference signal (REF_{IN}) available and the channel resolution (f_{RES}) required at the RF output. For example, a GSM system with 13 MHz REF_{IN} sets the modulus to 65. This means the RF output resolution (f_{RES}) is the

200 kHz (13 MHz/65) necessary for GSM. With dither off, the fractional spur interval depends on the modulus values chosen (see Table 6).

REFERENCE DOUBLER AND REFERENCE DIVIDER

The reference doubler on-chip allows the input reference signal to be doubled. This is useful for increasing the PFD comparison frequency. Making the PFD frequency higher improves the noise performance of the system. Doubling the PFD frequency usually improves noise performance by 3 dB. It is important to note that the PFD cannot operate above 32 MHz due to a limitation in the speed of the Σ - Δ circuit of the N-divider.

The reference divide-by-2 divides the reference signal by 2, resulting in a 50% duty cycle PFD frequency. This is necessary for the correct operation of the cycle slip reduction (CSR) function. See the Cycle Slip Reduction for Faster Lock Times section for more information.

12-BIT PROGRAMMABLE MODULUS

Unlike most other fractional-N PLLs, the ADF4150 allows the user to program the modulus over a 12-bit range. This means the user can set up the part in many different configurations for the application, when combined with the reference doubler and the 10-bit R counter.

For example, consider an application that requires 1.75 GHz RF and 200 kHz channel step resolution. The system has a 13 MHz reference signal.

One possible setup is feeding the 13 MHz directly to the PFD and programming the modulus to divide by 65. This results in the required 200 kHz resolution.

Another possible setup is using the reference doubler to create 26 MHz from the 13 MHz input signal. This 26 MHz is then fed into the PFD programming the modulus to divide by 130. This also results in 200 kHz resolution and offers superior phase noise performance over the previous setup.

The programmable modulus is also very useful for multi-standard applications. If a dual-mode phone requires PDC and GSM 1800 standards, the programmable modulus is a great benefit. PDC requires 25 kHz channel step resolution, whereas GSM 1800 requires 200 kHz channel step resolution.

A 13 MHz reference signal can be fed directly to the PFD, and the modulus can be programmed to 520 when in PDC mode (13 MHz/520 = 25 kHz).

The modulus needs to be reprogrammed to 65 for GSM 1800 operation (13 MHz/65 = 200 kHz).

It is important that the PFD frequency remain constant (13 MHz). This allows the user to design one loop filter for both setups without running into stability issues. It is important to remember that the ratio of the RF frequency to the PFD frequency principally affects the loop filter design, not the actual channel spacing.

CYCLE SLIP REDUCTION FOR FASTER LOCK TIMES

As outlined in the Noise and Spur Mode section, the ADF4150 contains a number of features that allow optimization for noise performance. However, in fast locking applications, the loop bandwidth generally needs to be wide, and therefore, the filter does not provide much attenuation of the spurs. If the cycle slip reduction feature is enabled, the narrow loop bandwidth is maintained for spur attenuation but faster lock times are still possible.

Cycle Slips

Cycle slips occur in integer-N/fractional-N synthesizers when the loop bandwidth is narrow compared to the PFD frequency. The phase error at the PFD inputs accumulates too fast for the PLL to correct, and the charge pump temporarily pumps in the wrong direction. This slows down the lock time dramatically. The ADF4150 contains a cycle slip reduction feature that extends the linear range of the PFD, allowing faster lock times without modifications to the loop filter circuitry.

When the circuitry detects that a cycle slip is about to occur, it turns on an extra charge pump current cell. This outputs a constant current to the loop filter, or removes a constant current from the loop filter (depending on whether the VCO tuning voltage needs to increase or decrease to acquire the new frequency). The effect is that the linear range of the PFD is increased. Loop stability is maintained because the current is constant and is not a pulsed current.

If the phase error increases again to a point where another cycle slip is likely, the ADF4150 turns on another charge pump cell. This continues until the ADF4150 detects the VCO frequency has gone past the desired frequency. The extra charge pump cells are turned off one by one until all the extra charge pump cells have been disabled and the frequency is settled with the original loop filter bandwidth.

Up to seven extra charge pump cells can be turned on. In most applications, it is enough to eliminate cycle slips altogether, giving much faster lock times.

Setting Bit DB18 in the Register 3 to 1 enables cycle slip reduction. Note that the PFD requires a 45% to 55% duty cycle for CSR to operate correctly.

SPURIOUS OPTIMIZATION AND FAST LOCK

Narrow loop bandwidths can filter unwanted spurious signals, but these usually have a long lock time. A wider loop bandwidth will achieve faster lock times, but a wider loop bandwidth may lead to increased spurious signals inside the loop bandwidth.

The fast lock feature can achieve the same fast lock time as the wider bandwidth, but with the advantage of a narrow final loop bandwidth to keep spurs low.

FAST-LOCK TIMER AND REGISTER SEQUENCES

If the fast-lock mode is used, a timer value is to be loaded into the PLL to determine the duration of the wide bandwidth mode.

When Bits [DB16:DB15] in Register 3 are set to 0, 1 (fast lock enable), the timer value is loaded by the 12-bit clock divider value. The following sequence must be programmed to use fast lock:

- 1) Initialization sequence (see the Initialization Sequence section); occurs only once after powering up the part.
- 2) Load Register 3 by setting Bits [DB16:DB15] to 0, 1 and the chosen fast-lock timer value [DB14:DB3]. Note that the duration the PLL remains in wide bandwidth is equal to the fast-lock timer/ f_{PFD} .

FAST LOCK—AN EXAMPLE

If a PLL has reference frequencies of 13 MHz and $f_{\text{PFD}} = 13$ MHz and a required lock time of 50 μs , the PLL is set to wide bandwidth for 40 μs . This example assumes a modulus of 65 for channel spacing of 200 kHz.

If the time period set for the wide bandwidth is 40 μs , then

$$\text{Fast-Lock Timer Value} = \text{Time in Wide Bandwidth} \times f_{\text{PFD}} / \text{MOD}$$

$$\text{Fast-Lock Timer Value} = 40 \mu\text{s} \times 13 \text{ MHz} / 65 = 8$$

Therefore, 8 must be loaded into the clock divider value in Register 3 in Step 1 of the sequence described in the Fast-Lock Timer and Register Sequences section.

FAST LOCK—LOOP FILTER TOPOLOGY

In order to use fast-lock mode, the damping resistor in the loop filter is reduced to $\frac{1}{4}$ of its value while in wide bandwidth mode. To achieve the wider loop filter bandwidth, the charge pump current increases by a factor of 16, and to maintain loop stability the damping resistor must be reduced a factor of $\frac{1}{4}$. To enable fast lock, the SW pin is shorted to the GND pin by settings Bits [DB16:DB15] in Register 3 to 0, 1. The following two topologies are available:

- The damping resistor (R1) is divided into two values (R1 and R1A) that have a ratio of 1:3 (see Figure 23).
- An extra resistor (R1A) is connected directly from SW, as shown in Figure 24. The extra resistor is calculated such that the parallel combination of an extra resistor and the damping resistor (R1) is reduced to $\frac{1}{4}$ of the original value of R1 (see Figure 24).

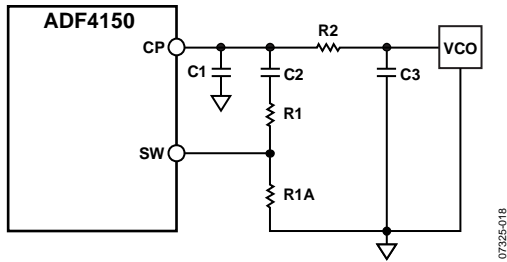

Figure 23. Fast-Lock Loop Filter Topology—Topology 1

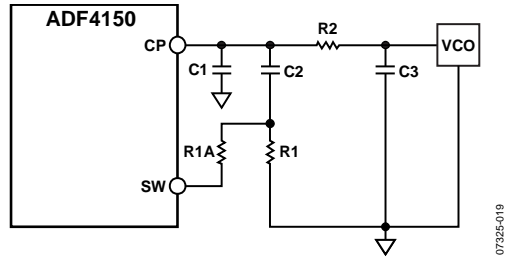

Figure 24. Fast-Lock Loop Filter Topology—Topology 2

SPUR MECHANISMS

This section describes the three different spur mechanisms that arise with a fractional-N synthesizer and how to minimize them in the ADF4150.

Fractional Spurs

The fractional interpolator in the ADF4150 is a third order Σ - Δ modulator (SDM) with a modulus (MOD) that is programmable to any integer value from 2 to 4095. In low spur mode (dither enabled) the minimum allowable value of MOD is 50. The SDM is clocked at the PFD reference rate (f_{PFD}) that allows PLL output frequencies to be synthesized at a channel step resolution of f_{PFD}/MOD .

In low noise mode (dither off), the quantization noise from the Σ - Δ modulator appears as fractional spurs. The interval between spurs is f_{PFD}/L , where L is the repeat length of the code sequence in the digital Σ - Δ modulator. For the third-order modulator used in the ADF4150, the repeat length depends on the value of MOD, as listed in Table 6.

Table 6. Fractional Spurs with Dither Off

Condition (Dither Off)	Repeat Length	Spur Interval
If MOD is divisible by 2, but not 3	$2 \times MOD$	Channel step/2
If MOD is divisible by 3, but not 2	$3 \times MOD$	Channel step/3
If MOD is divisible by 6	$6 \times MOD$	Channel step/6
Otherwise	MOD	Channel step

In low spur mode (dither enabled), the repeat length is extended to 2^{21} cycles, regardless of the value of MOD, which makes the quantization error spectrum look like broadband noise. This may degrade the in-band phase noise at the PLL output by as much as 10 dB. For lowest noise, dither off is a better choice, particularly when the final loop bandwidth is low enough to attenuate even the lowest frequency fractional spur.

Integer Boundary Spurs

Another mechanism for fractional spur creation is the interactions between the RF VCO frequency and the reference frequency. When these frequencies are not integer related (the point of a fractional-N synthesizer) spur sidebands appear on the VCO output spectrum at an offset frequency that corresponds to the beat note or difference frequency between an integer multiple of the reference and the VCO frequency. These spurs are attenuated by the loop filter and are more noticeable on channels close to integer multiples of the reference where the difference frequency can be inside the loop bandwidth, hence the name integer boundary spurs.

Reference Spurs

Reference spurs are generally not a problem in fractional-N synthesizers because the reference offset is far outside the loop bandwidth. However, any reference feed-through mechanism that bypasses the loop may cause a problem. Feed through of low levels of on-chip reference switching noise, through the RF_{IN} pin back to the VCO, can result in reference spur levels as high as -90 dBc. PCB layout needs to ensure adequate isolation between VCO traces and the input reference to avoid a possible feed through path on the board.

SPUR CONSISTENCY AND FRACTIONAL SPUR OPTIMIZATION

With dither off, the fractional spur pattern due to the quantization noise of the SDM also depends on the particular PHASE word with which the modulator is seeded.

The PHASE word can be varied to optimize the fractional and subfractional spur levels on any particular frequency. Thus, a look-up table of PHASE values corresponding to each frequency can be constructed for use when programming the ADF4150.

If a look-up table is not used, keep the PHASE word at a constant value to ensure consistent spur levels on any particular frequency.

PHASE RESYNC

The output of a fractional-N PLL can settle to any one of the MOD phase offsets with respect to the input reference, where MOD is the fractional modulus. The PHASE resync feature in the ADF4150 produces a consistent output phase offset with respect to the input reference. This is necessary in applications where the output phase and frequency are important, such as digital beam forming. See the PHASE Programmability section for how to program a specific RF output phase when using PHASE resync.

PHASE resync is enabled by setting Bits [DB16:DB15] in Register 3 to 1, 0. When PHASE resync is enabled, an internal timer generates sync signals at intervals of t_{SYNC} given by the following formula:

$$t_{SYNC} = CLK_DIV_VALUE \times MOD \times t_{PFD}$$

where:

t_{PFD} is the PFD reference period.

CLK_DIV_VALUE is the decimal value programmed in Bits [DB14:DB3] of Register 3, and can be any integer in the range of 1 to 4095.

MOD is the modulus value programmed in Bits [DB14:DB3] of Register 1 (R1).

When a new frequency is programmed, the second sync pulse after the LE rising edge is used to resynchronize the output phase to the reference. The t_{SYNC} time is to be programmed to a value that is as least as long as the worst-case lock time. This guarantees the PHASE resync occurs after the last cycle slip in the PLL settling transient.

In the example shown in Figure 25, the PFD reference is 25 MHz and $MOD = 125$ for a 200 kHz channel spacing. t_{SYNC} is set to 400 μs by programming $CLK_DIV_VALUE = 80$.

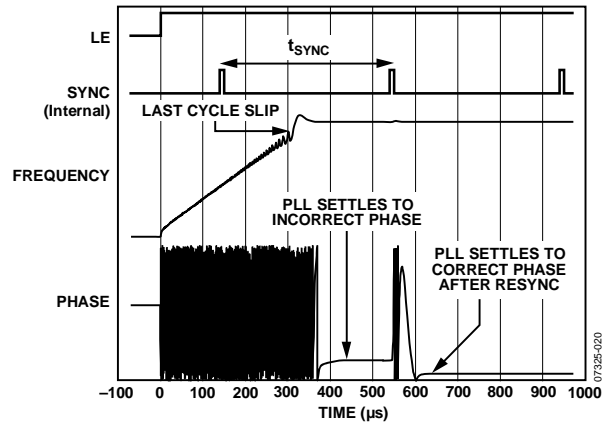

Figure 25. PHASE Resync Example

PHASE Programmability

The PHASE word in Register 1 controls the RF output phase. As this word is swept from 0 to MOD, the RF output phase sweeps over a 360° range in steps of 360°/MOD.

APPLICATIONS INFORMATION

DIRECT CONVERSION MODULATOR

Direct conversion architectures are increasingly being used to implement base station transmitters. Figure 26 shows how Analog Devices, Inc. parts can be used to implement such a system.

The circuit block diagram shows the AD9788 TxDAC[®] being used with the ADL5375. The use of dual integrated DACs, such as the AD9788 with its specified ± 0.02 dB and ± 0.004 dB gain and offset matching characteristics, ensures minimum error contribution (over temperature) from this portion of the signal chain.

The local oscillator (LO) is implemented using the ADF4150. The low-pass filter was designed using ADIsimPLL for a channel spacing of 200 kHz and a closed-loop bandwidth of 35 kHz.

The LO ports of the AD5375 can be driven differentially from the complementary RF_{OUTA} and RF_{OUTB} outputs of the ADF4150. This gives better performance than a single-ended LO driver and eliminates the use of a balun to convert from a single-ended LO input to the more desirable differential LO inputs for the AD5375. The typical rms phase noise (100 Hz to 5 MHz) of the LO in this configuration is 0.61° rms.

The ADL5375 accepts LO drive levels from -10 dBm to 0 dBm. The optimum LO power can be software programmed on the ADF4150, which allows levels from -4 dBm to +5 dBm from each output.

The RF output is designed to drive a 50 Ω load but must be ac-coupled, as shown in Figure 26. If the I and Q inputs are driven in quadrature by 2 V p-p signals, the resulting output power from the modulator is approximately 2 dBm.

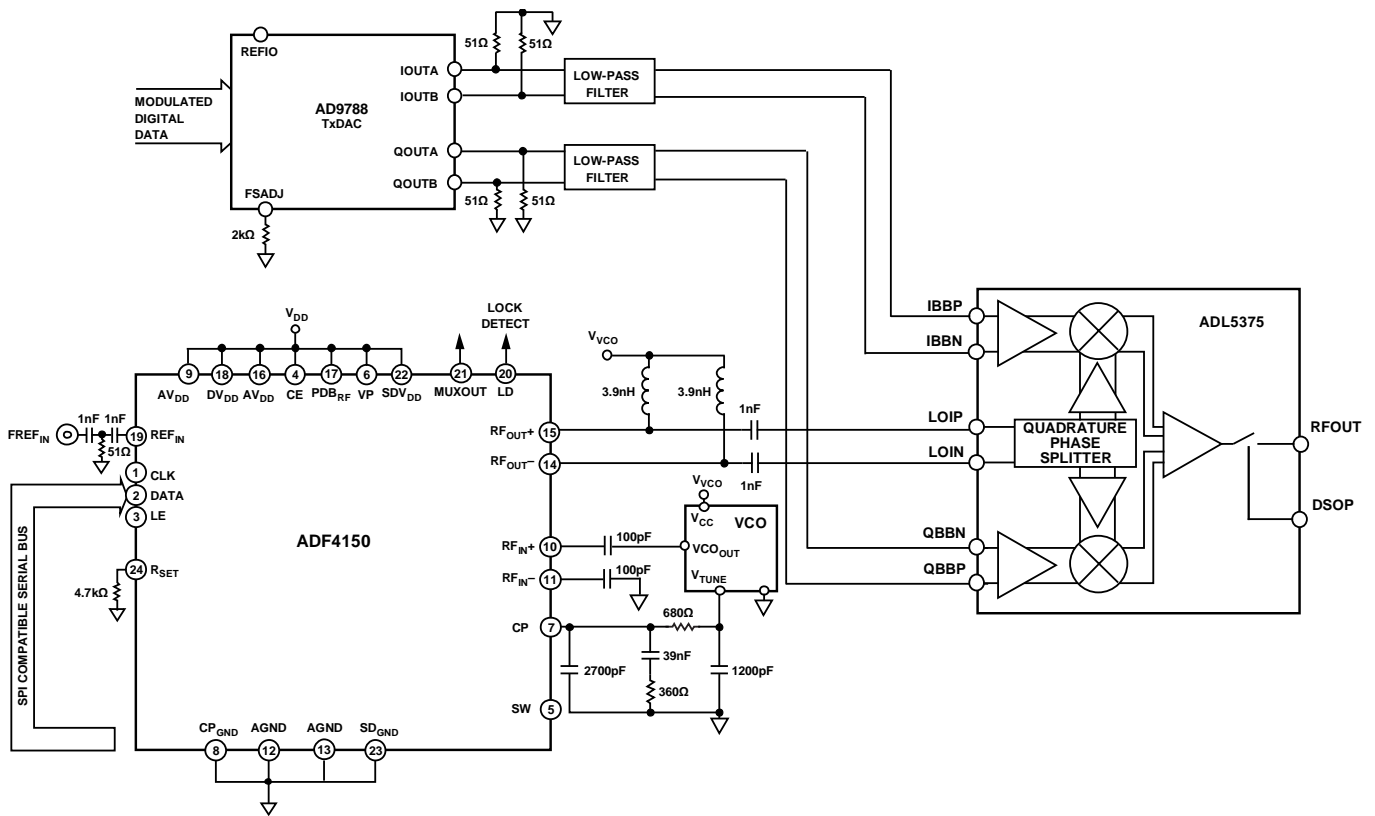

Figure 26 Direct Conversion Modulator

INTERFACING

The ADF4150 family has a simple SPI®-compatible serial interface for writing to the device. CLK, DATA, and LE control the data transfer. When LE goes high, the 32 bits that have been clocked into the appropriate register on each rising edge of CLK are transferred to the appropriate latch. See Figure 2 for the timing diagram and Table 5 for the register address table.

ADuC812 Interface

Figure 27 shows the interface between the ADF4150 family and the ADuC812 MicroConverter®. Because the ADuC812 is based on an 8051 core, this interface can be used with any 8051 based microcontroller. The MicroConverter is set up for SPI master mode with CPHA = 0. To initiate the operation, the I/O port driving LE is brought low. Each latch of the ADF4150 family needs a 32-bit word, which is accomplished by writing four 8-bit bytes from the MicroConverter to the device. When the fourth byte has been written, the LE input should be brought high to complete the transfer.

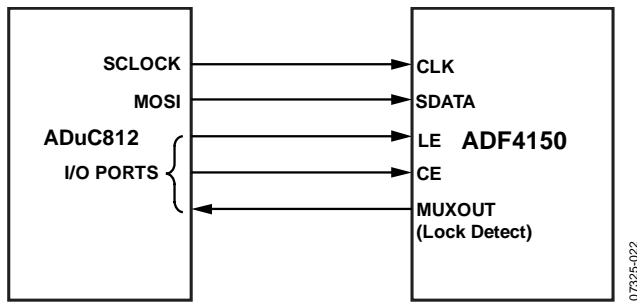

Figure 27. ADuC812 to ADF4150 Interface

I/O port lines on the ADuC812 are also used to control power-down (CE input) and detect lock (MUXOUT configured as lock detect and polled by the port input). When operating in the described mode, the maximum SCLOCK rate of the ADuC812 is 4 MHz. This means that the maximum rate at which the output frequency can be changed is 125 kHz.

ADSP-21xx Interface

Figure 28 shows the interface between the ADF4150 family and the ADSP-21xx digital signal processor. The ADF4150 family needs a 32-bit serial word for each latch write. The easiest way to accomplish this using the ADSP-21xx family is to use the autobuffered transmit mode of operation with alternate framing. This provides a means for transmitting an entire block of serial data before an interrupt is generated.

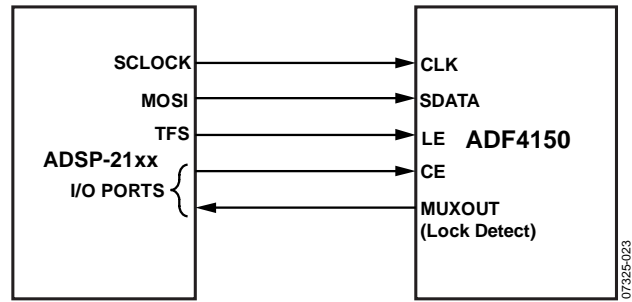

Figure 28. ADSP-21xx to ADF4150 Interface

Set up the word length for 8 bits and use four memory locations for each 32-bit word. To program each 32-bit latch, store the 8-bit bytes, enable the autobuffered mode, and write to the transmit register of the DSP. This last operation initiates the autobuffer transfer.

PCB DESIGN GUIDELINES FOR CHIP SCALE PACKAGE

The lands on the chip scale package (CP-24-3) are rectangular. The PCB pad for these is to be 0.1 mm longer than the package land length and 0.05 mm wider than the package land width. The land is to be centered on the pad. This ensures the solder joint size is maximized. The bottom of the chip scale package has a central thermal pad.

The thermal pad on the PCB is to be at least as large as the exposed pad. On the PCB, there is to be a minimum clearance of 0.25 mm between the thermal pad and the inner edges of the pad pattern. This ensures that shorting is avoided.

Thermal vias can be used on the PCB thermal pad to improve the thermal performance of the package. If vias are used, they are to be incorporated in the thermal pad at 1.2 mm pitch grid. The via diameter is to be between 0.3 mm and 0.33 mm, and the via barrel is to be plated with one ounce copper to plug the via.

OUTPUT MATCHING

There are a number of ways to match the output of the ADF4150 for optimum operation; the most basic is to use a 50 Ω resistor to AV_{DD}. A dc bypass capacitor of 100 pF is connected in series as shown in Figure 29. Because the resistor is not frequency dependent, this provides a good broadband match. The output power in this circuit into a 50 Ω load typically gives values chosen by Bit D2 and Bit D1 in Register 4 (R4).

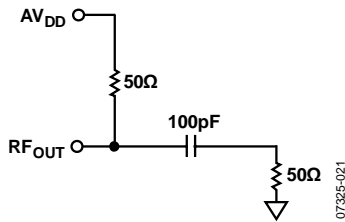

Figure 29. Simple ADF4150 Output Stage

A better solution is to use a shunt inductor (acting as an RF choke) to AV_{DD}. This gives a better match and, therefore, more output power.

Experiments have shown the circuit shown in Figure 30 provides an excellent match to 50 Ω for the WCDMA UMTS Band 1 (2110 – 2170 MHz). The maximum output power in that case is about 7 dBm. Both single-ended architectures can be examined using the EVAL-ADF4150EB1Z evaluation board.

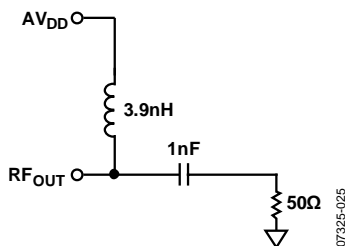
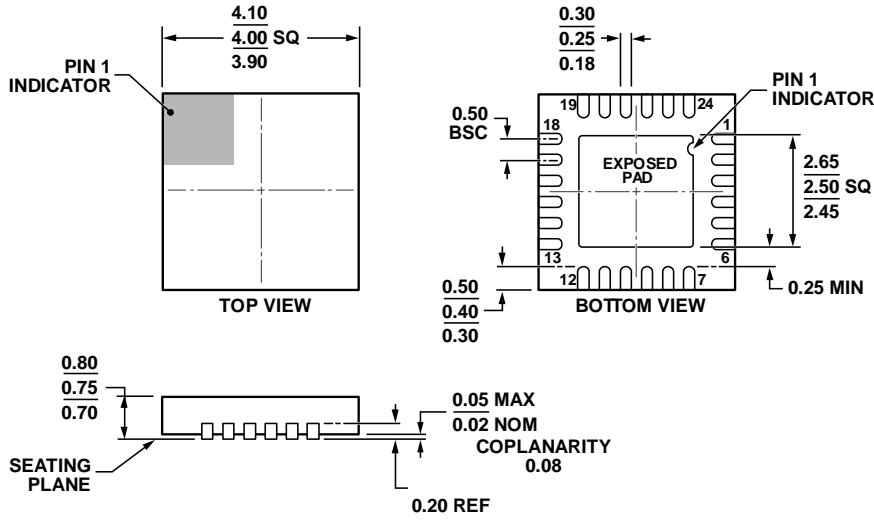

Figure 30. Optimum ADF4150 Output Stage

If differential outputs are not needed, the unused output can be terminated or combined with both outputs using a balun.

OUTLINE DIMENSIONS



COMPLIANT TO JEDEC STANDARDS MO-220-WGGD.

112108-A

Figure 31. 24-Lead Lead Frame Chip Scale Package [LFCSP_VQ]
 Dimensions shown in millimeters(Package drawing subject to change).

ORDERING GUIDE

Model	Temperature Range	Package Description	Package Option
ADF4150BCPZ ¹	-40°C to +85°C	24-Lead Lead Frame Chip Scale Package [LFCSP_VQ]	CP-24-7
ADF4150BCPZ-RL7 ¹	-40°C to +85°C	24-Lead Lead Frame Chip Scale Package [LFCSP_VQ]	CP-24-7
EVAL-ADF4150EB1Z ¹		Evaluation Board	

¹Z = RoHS Compliant Part.

NOTES