

Voltage Variable Absorptive Attenuator, 800 - 1000 MHz

AT10-0009

Features

- Input IP₃: +31 dBm Min. (Full Attenuation Range)
- Input IP₃ is **15 -20 dB** Better Than GaAs
- Linear Operation: +20 dBm Min.
- Plastic SOIC, Wide Body, SMT Package
- 38 dB Dynamic Range (With 30 mA Bias Current)
- Single Control Voltage
- 50 ohm Impedance
- Linear Driver, DR65-0002, Available
- Test Boards are Available
- Tape and Reel Packaging Available

Description

M/A-COM's AT10-0009 is a PIN diode based voltage variable attenuator. This device is in a SOIC-16, wide body plastic surface mount package. These attenuators have linear operating power and input intercept point levels 15 - 20 dB better than GaAs FET MMIC voltage variable attenuators. They are ideally suited for use where low distortion, high linear operating power and high dynamic range are required. These devices are optimized for the GSM frequency band, but exhibit excellent performance and repeatability over the entire specified frequency band. The AT10-0009 is ideally suited for wireless communications systems.

SOW-16

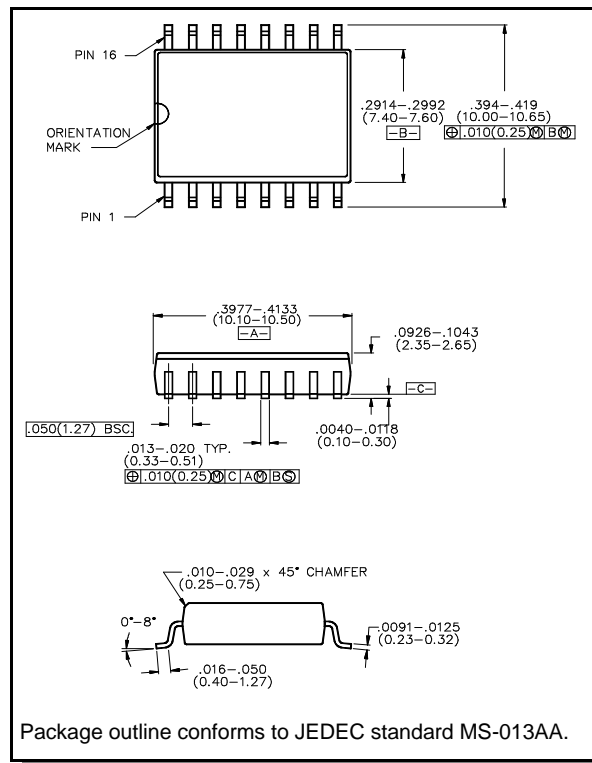

Electrical Specifications: T_A = 25°C

Parameter	Test Conditions	Frequency	Units	Min	Typical	Max
Insertion Loss	0 volts	800-1000 MHz	dB	—	3.5	4.2
		925 - 960 MHz	dB	—	3.3	3.9
Attenuation (Above Loss)	12 mA bias current	800-1000 MHz	dB	30	-	—
		925 - 960 MHz	dB	33	38	—
Frequency Flatness	0 to 30 dB attenuation	800-1000 MHz	dB	—	1.5	2.5
		925 - 960 MHz	dB	—	0.4	0.8
VSWR	0 to 30 dB attenuation	800-1000 MHz	Ratio	—	1.6:1	2.0:1
		925 - 960 MHz	Ratio	—	1.4:1	1.7:1
Switching Speed	50% Control to 90%/10% RF	800-1000 MHz	μs	—	—	10.0
Linear Operation	—	800-1000 MHz	dBm	—	+20	—
Input IP ₃	Two-tone inputs up to +10 dBm	800-1000 MHz	dBm	+35	+40	—
I _{Control}	—	800-1000 MHz	mA	—	—	30

Pin Configuration

Pin #	Function	Pin #	Function
1	GND	9	GND
2	RF	10	RF
3	GND	11	GND
4	GND	12	GND
5	GND	13	GND
6	GND	14	GND
7	Bias ²	15	Bias ²
8	GND	16	GND

2. Bias currents may be applied to pin 7 or 15. The unused pin should be isolated.

Recommended PCB Configuration

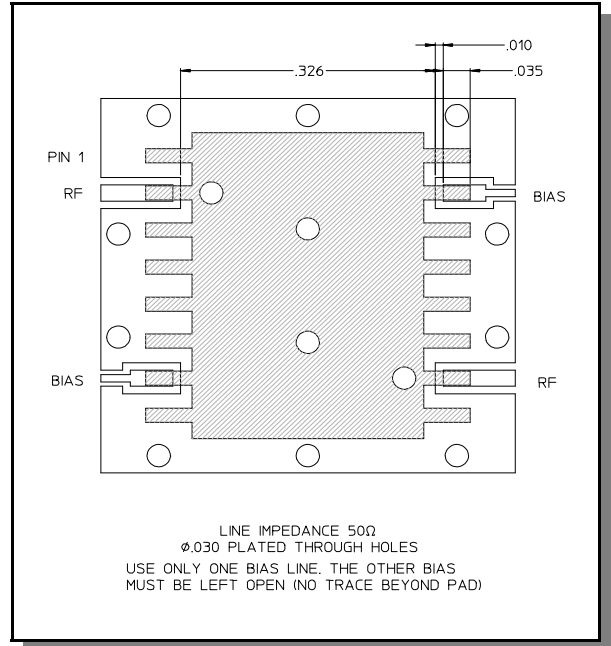

Absolute Maximum Ratings ¹

Parameter	Absolute Maximum
Max. Input Power	+27 dBm
Operating Temperature	-40°C to +85°C
Storage Temperature	-65°C to +125°C

1. Operation of this device above any one of these parameters may cause permanent damage.

Typical Performance Curves

Insertion Loss

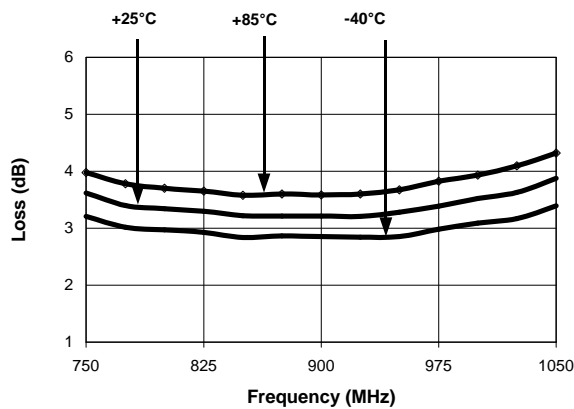

Attenuation Flatness (dB) @ +25°C

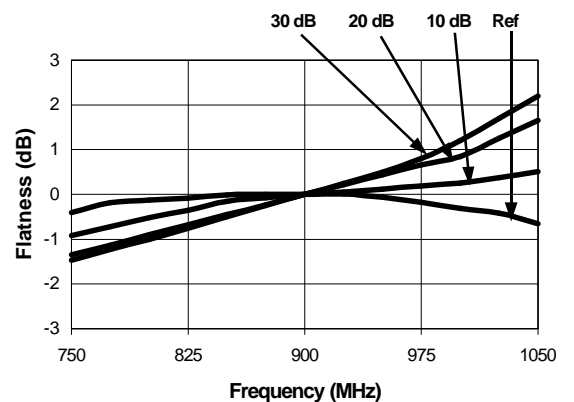

Specifications subject to change without notice.

- North America: Tel. (800) 366-2266
- Asia/Pacific: Tel.+81-44-844-8296, Fax +81-44-844-8298
- Europe: Tel. +44 (1344) 869 595, Fax+44 (1344) 300 020

Visit www.macom.com for additional data sheets and product information.

Typical Performance Curves

Typical VSWR @ +25°C

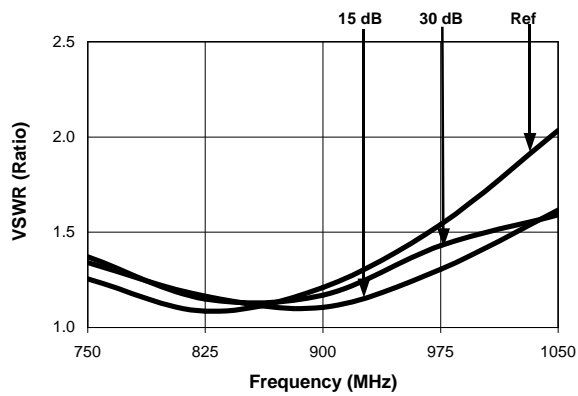

Attenuation vs. Bias Current

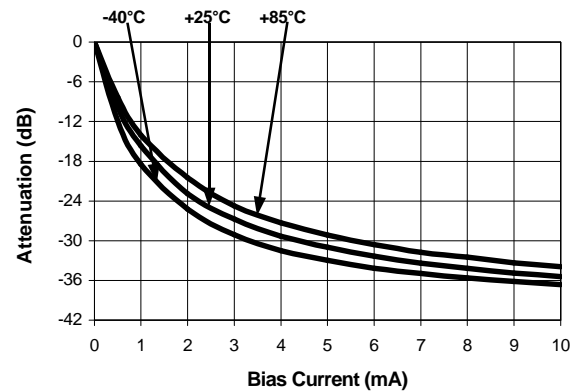

Ordering Information

Part Number	Package
AT10-0009	Tube
AT10-0009TR	Tape and Reel (1K Reel)
AT10-0009-TB	Unit Mounted on Test Board
DR65-0002-TBG	Unit with Driver on Test Board

Specifications subject to change without notice.

- North America: Tel. (800) 366-2266
- Asia/Pacific: Tel.+81-44-844-8296, Fax +81-44-844-8298
- Europe: Tel. +44 (1344) 869 595, Fax+44 (1344) 300 020

Visit www.macom.com for additional data sheets and product information.