

REC/PB AUDIO HEAD SWITCH

DESCRIPTION

The μ PC1290C is a monolithic integrated circuit designed for the recording/playback head turnover switch of a tape deck.

It is composed of two reference voltage source, four comparators and REC/PB switches.

The IC is encapsulated in 14 pin dual-in-line plastic package.

FEATURES

- High Isolation Voltage: 100 V_{p-p} MIN. (100 kHz)
- Low On Resistance.
- TTL Level Operation.
- High Reliability by Electric Switch.
- 2 Switch Circuits are Built-In.

BLOCK DIAGRAM

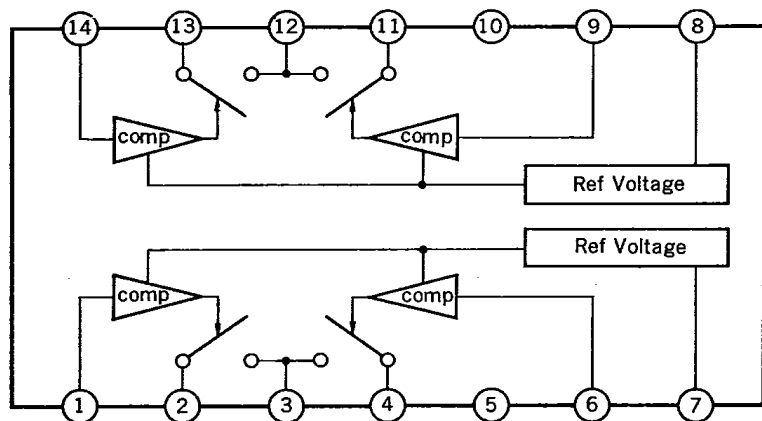

CONNECTION DIAGRAM

PIN NO.	SYMBOL	CONNECTION
1	IN _{R1}	REC SW ₁ Control Terminal
2	SW _{R1}	REC SW ₁ Terminal
3	GND	GND Terminal
4	SW _{P1}	PB SW ₁ Terminal
5	GND	GND Terminal
6	IN _{P1}	PB SW ₁ Control Terminal
7	VCC1	VCC1 Terminal
8	VCC2	VCC2 Terminal
9	IN _{P2}	PB SW ₂ Control Terminal
10	GND	GND Terminal
11	SW _{P2}	PB SW ₂ Terminal
12	GND	GND Terminal
13	SW _{R2}	REC SW ₂ Terminal
14	IN _{R2}	REC SW ₂ Control Terminal

ABSOLUTE MAXIMUM RATINGS (T_a = 25 °C)

www.DataSheet4U.com

Supply Voltage	V _{CC}	16	V
Power Dissipation	P _D	400*	mW
Operating Temperature Range	T _{opt}	-20 to +70	°C
Storage Temperature Range	T _{stg}	-40 to +125	°C
Pin 4, 11 Input Voltage (DC)	V _{in 4} , V _{in 11}	±65	V _{p-p}
Pin 4, 11 Input Current	I _{in 4} , I _{in 11}	±1.5	mA
Pin 2, 13 Input Voltage	V _{in 2} , V _{in 13}	±0.2	V
Pin 2, 13 Input Current	I _{in 2} , I _{in 13}	±10	mA

*Value at T_a = 70 °C

RECOMMENDED OPERATING CONDITION (T_a = 25 °C)

CHARACTERISTIC	SYMBOL	MIN.	TYP.	MAX.	UNIT
Supply Voltage	V _{CC}	4.5	9	14.4	V
Input Voltage (4, 11 pin)	V _{i4} , V _{i11}	—	—	100*	V _{p-p}
High Level Input Voltage R, P	V _{CRH} , V _{CPH}	2.5	—	8.0**	V

* f = 100 kHz, when Input Voltage (4, 11 pin) is more than 100 V_{p-p} AC, input voltage waveform has large distortion.

** When the V_{CC} is less than 8 V, V_{CRH}, V_{CPH} MAX. are V_{CC}.

ELECTRICAL CHARACTERISTICS (T_a = 25 °C, V_{CC} = 9.0 V)

CHARACTERISTIC	SYMBOL	MIN.	TYP.	MAX.	UNIT	TEST CONDITION
Supply Current 1	I _{CC 1}			2	mA	V _{CR} = 0 V, V _{CP} = 0 V
Supply Current 2	I _{CC 2}			15	mA	V _{CR} = 5 V, V _{CP} = 5 V
Low Level Input Voltage R	V _{CRL}	0		1.5	V	
High Level Input Voltage R	V _{CRH}	2.5		8	V	
Low Level Input Voltage P	V _{CPL}	0		1.5	V	
High Level Input Voltage P	V _{CPH}	2.5		8	V	
High Level Input Current R	I _{CR}		50	100	μA	V _{CR} = 5 V
High Level Input Current P	I _{CP}		50	100	μA	V _{CP} = 5 V
Pin 2, 13 ON Resistance	R _R		5	10	Ω	V _{CR} = 5 V, I _R = ±1 mA
Pin 4, 11 ON Resistance	R _p		10	20	Ω	V _{CP} = 5 V, I _p = ±1 mA
Pin 2, 13 Leak Current	I _{LR}			±2	μA	V _B = ±0.1 V
Pin 4, 11 Leak Current	I _{LP}			±10	μA	V _B = ±50 V
Pin 2, 13 Offset Voltage	V _{RO}		3	6	mV	V _{CR} = 5 V
Pin 4, 11 Offset Voltage	V _{PO}		4	15	mV	V _{CP} = 5 V

TEST CIRCUIT (CH1 ONLY)

www.DataSheet4U.com

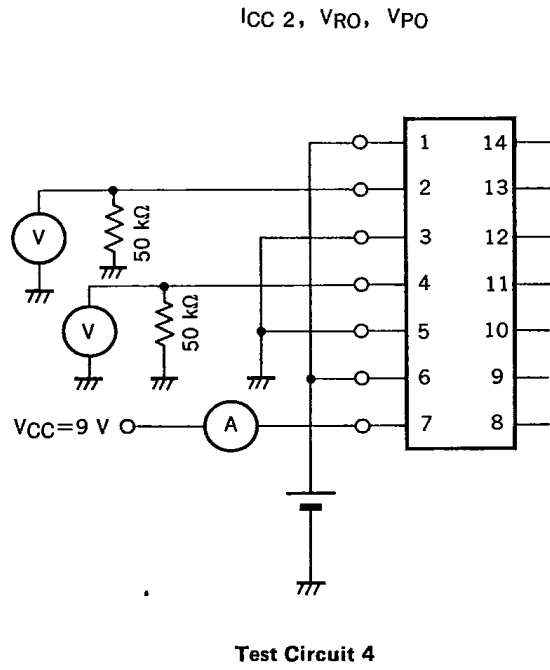
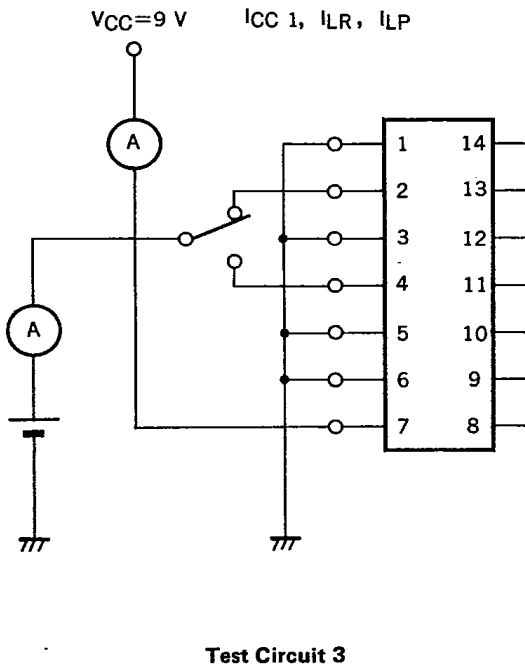
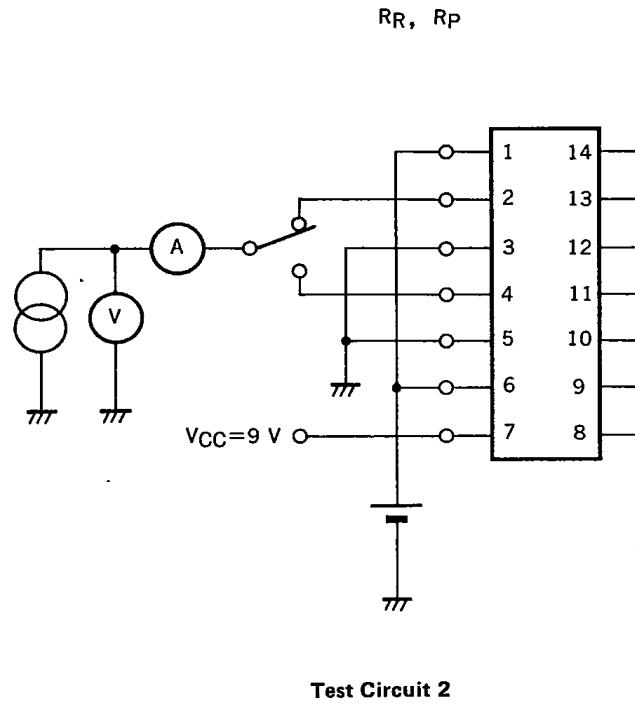
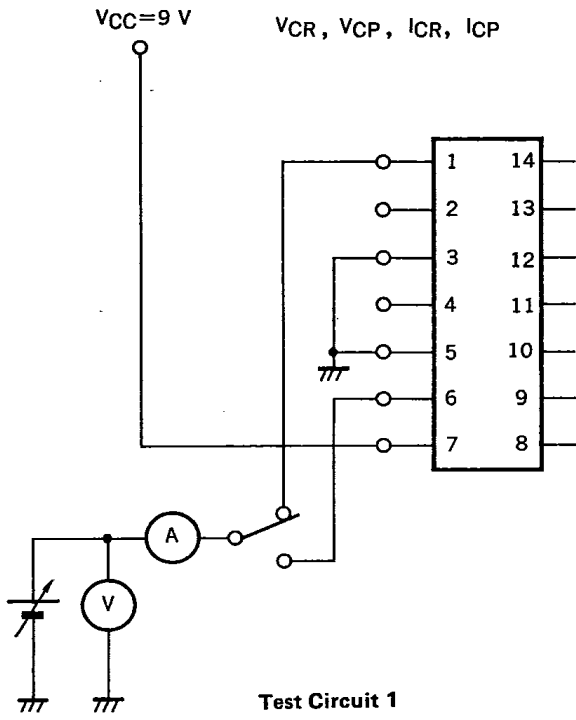

TYPICAL CHARACTERISTICS (T_a = 25 °C)

www.DataSheet4U.com

SUPPLY CURRENT vs. SUPPLY VOLTAGE

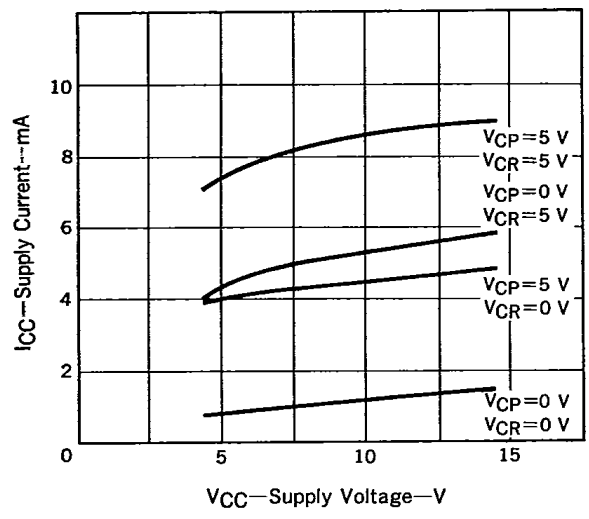

REC SW ON RESISTANCE CHARACTERISTICS

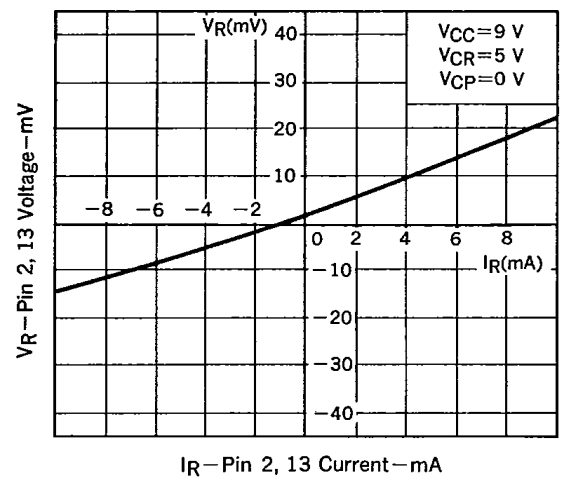

PB SW ON RESISTANCE CHARACTERISTICS

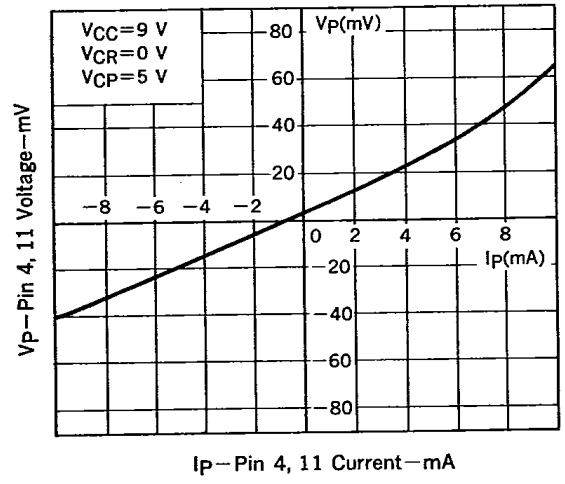

SUPPLY CURRENT vs. REC SW CONTROL VOLTAGE

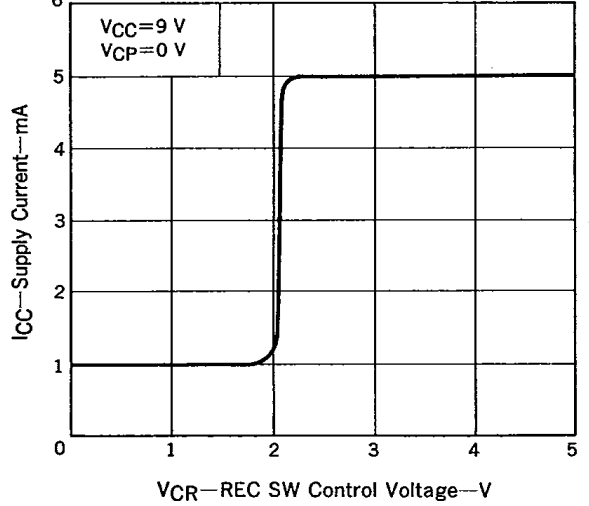

SUPPLY CURRENT vs. PB SW CONTROL VOLTAGE

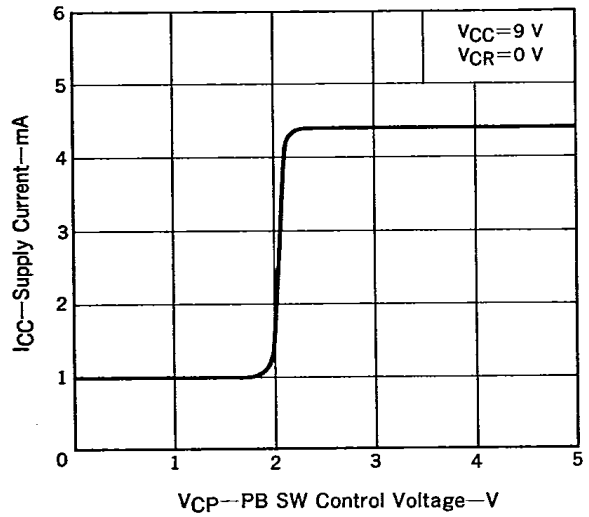

PIN 4, 11 VOLTAGE vs. FREQUENCY

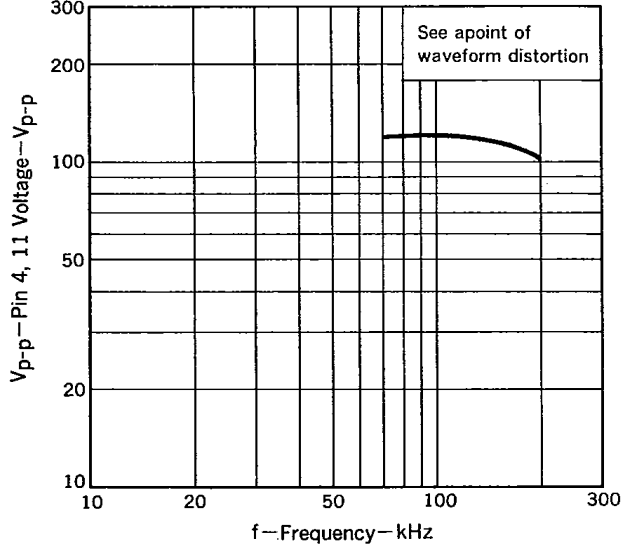

APPLICATION CIRCUIT

www.DataSheet4U.com

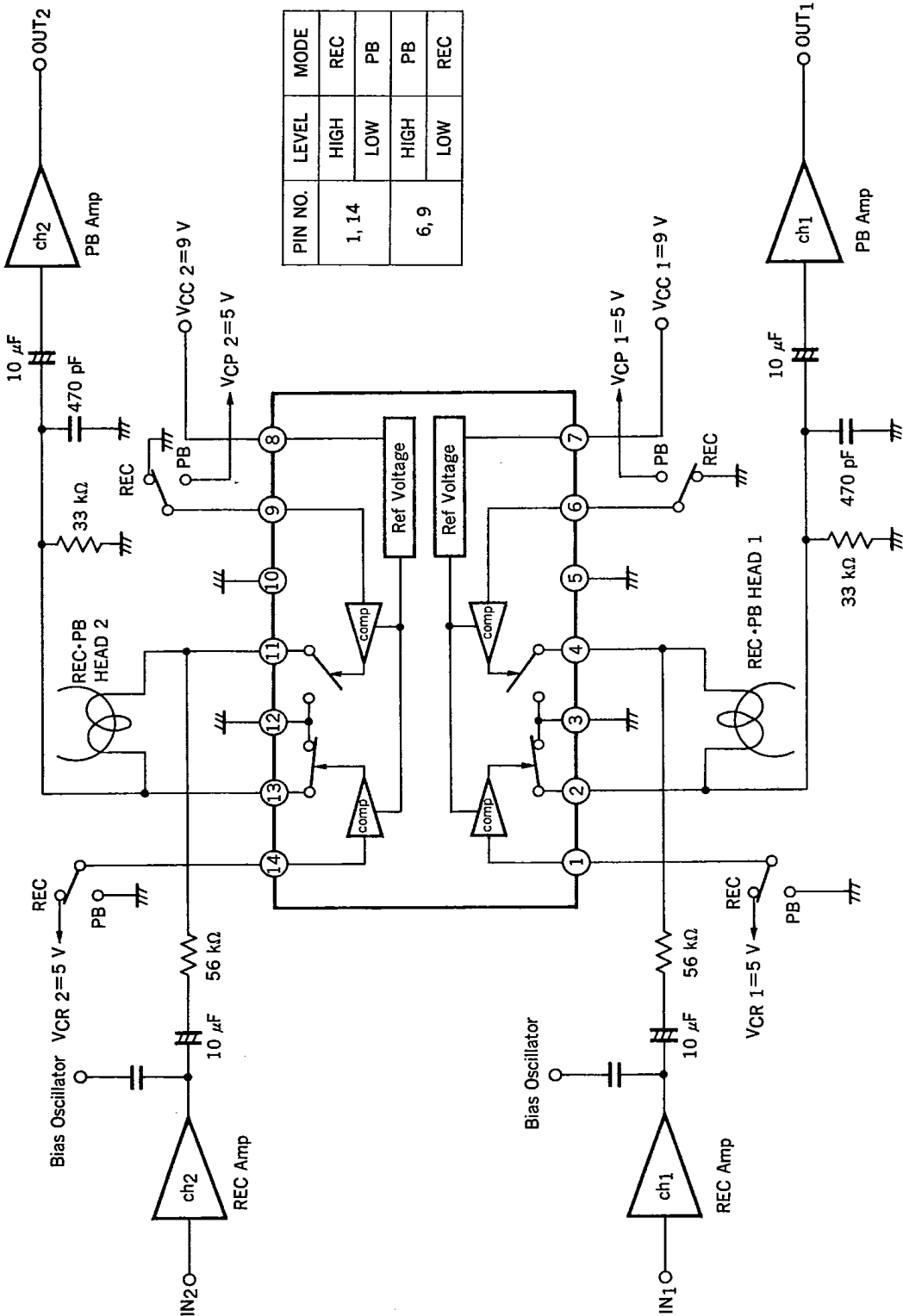

PIN NO.	LEVEL	MODE
1, 14	HIGH	REC
	LOW	PB
6, 9	HIGH	PB
	LOW	REC

14PIN PLASTIC DIP (300 mil)
www.DataSheet4U.com

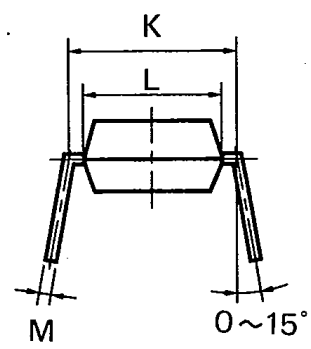
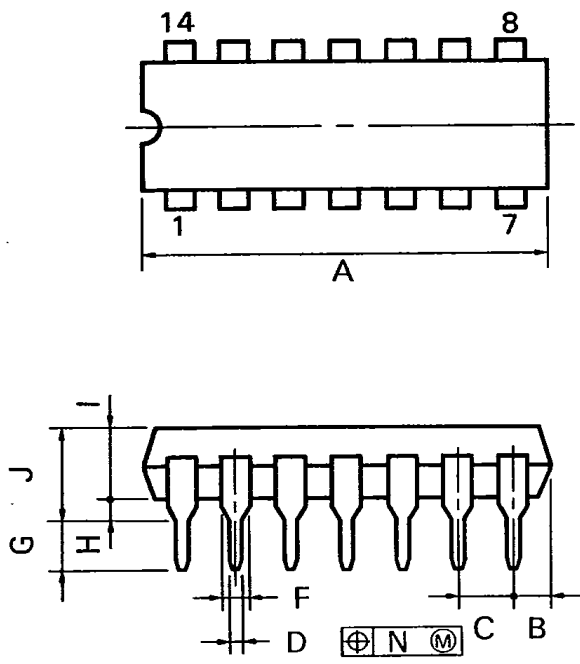

P14C-100-300B2

NOTES

- 1) Each lead centerline is located within 0.25 mm (0.01 inch) of its true position (T.P.) at maximum material condition.
- 2) Item "K" to center of leads when formed parallel.

ITEM	MILLIMETERS	INCHES
A	20.32 MAX.	0.800 MAX.
B	2.54 MAX.	0.100 MAX.
C	2.54 (T.P.)	0.100 (T.P.)
D	0.50 ^{+0.10}	0.020 ^{+0.004} _{-0.005}
F	1.1 MIN.	0.043 MIN.
G	3.5 ^{+0.3}	0.138 ^{+0.012}
H	0.51 MIN.	0.020 MIN.
I	4.31 MAX.	0.170 MAX.
J	5.08 MAX.	0.200 MAX.
K	7.62 (T.P.)	0.300 (T.P.)
L	6.5	0.256
M	0.25 ^{+0.10} _{-0.05}	0.010 ^{+0.004} _{-0.003}
N	0.25	0.01