

RESONANT CONVERTER TOPOLOGIES

by M. Bildgen

1. INTRODUCTION

Increasing the frequency of operation of power converters is desirable, as it allows the size of circuit magnetics and capacitors to be reduced, leading to cheaper and more compact circuits. However, increasing the frequency of operation also increases switching losses and hence reduces system efficiency. One solution to this problem is to replace the "chopper" switch of a standard SMPS topology (Buck, Boost etc.) with a "resonant" switch, which uses the resonances of circuit capacitances and inductances to shape the waveform of either the current or the voltage across the switching element, such that when switching takes place, there is no current through or voltage across it, and hence no power dissipation - see figure 1. A circuit employing this technique is known as a resonant converter (or, more accurately, a quasi-resonant converter, as only part of the resonant sinusoid is utilized).

A Zero Current Switching (ZCS) circuit shapes the current waveform, while a Zero Voltage Switching (ZVS) circuit shapes the voltage waveform.

2. ZERO CURRENT SWITCH

A typical Zero Current Switch consists of a switch, S, in series with the resonant inductor L_{RES} , and the

resonant capacitor C_{RES} connected in parallel. Energy is supplied by a current source. The circuit and waveforms are shown in figure 2.

If an output transformer is used, in certain cases its parasitic inductance can be used as the resonant inductance (in both this and the zero voltage topology). However, as its value is generally not known, the resonant frequency will not be fixed, which may cause problems in the circuit design.

When the switch S is off, the resonant capacitor is charged up with a more or less constant current, and so the voltage across it rises linearly.

When the switch is turned on, the energy stored in the capacitor is transferred to the inductor, causing a sinusoidal current to flow in the switch. During the negative half wave, the current flows through the anti-parallel diode, and so in this period there is no current through or voltage across the switch; and it can be turned off without losses.

This type of switching is also known as thyristor mode, as it is one of the more suitable ways of using thyristors; these devices will only turn off if the current through them is forced to zero, which occurs naturally in this topology.

Figure 1. Current and voltage waveforms of hard and resonant switching systems

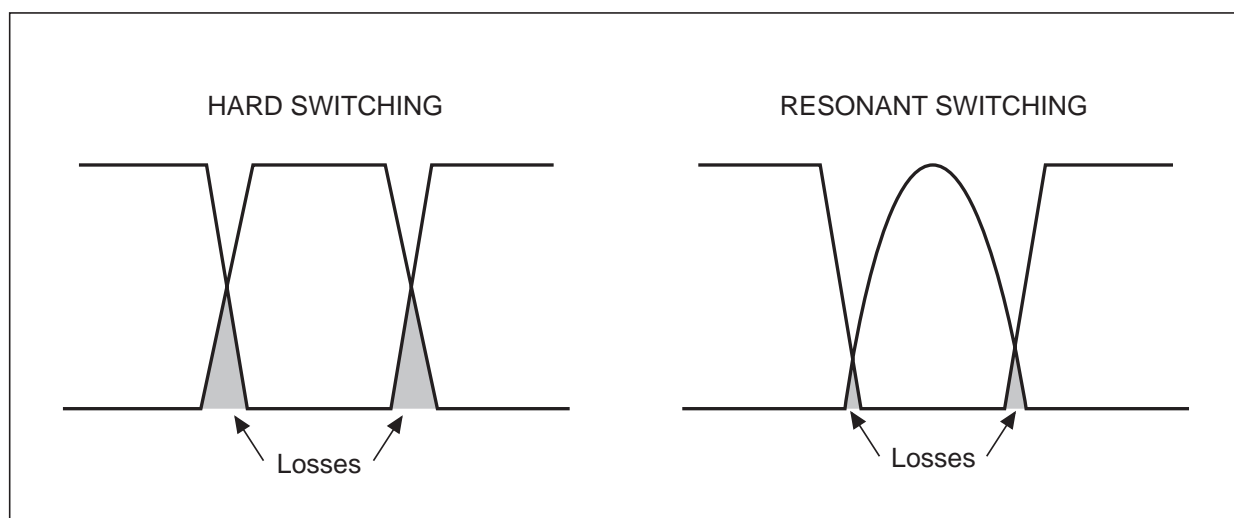

3. ZERO VOLTAGE SWITCH

A typical Zero Voltage Switch consists of a switch in series with a diode. The resonant capacitor is connected in parallel, and the resonant inductor is connected in series with this configuration. A voltage source connected in parallel injects the energy into this system. The circuit and waveforms are shown in figure 3.

When the switch is turned on, a linear current flows through the inductor. When the switch turns off, the energy that is stored in the inductor flows into the resonant capacitor. The resulting voltage across the capacitor and the switch is sinusoidal. The negative half-wave of the voltage is blocked by the diode. During this negative half wave, the current and voltage in the switch are zero, and so it can be turned on without losses.

4. POWER SEMICONDUCTORS IN RESONANT CONVERTERS

Because they require a substantial drive current, Bipolar transistors are not generally used in resonant converters, unless the base drive is provided by the resonant circuit itself (for example in TV deflection circuits and fluorescent lamp ballasts). Power MOSFETs and IGBTs, with their effectively capacitive inputs and low drive energy requirements, are the most frequently used types.

The graph in figure 4 shows the die size of Power MOSFETs and IGBTs required to conduct 1 amp with a voltage drop of 2 volts, against the maximum rated voltage. For low voltage applications, the MOSFET is interesting, as the die size is very small (and so the device is cheap). However for higher breakdown voltages, the IGBT is more suitable, as

Figure 2. Full-wave zero-current switch - topology and waveforms

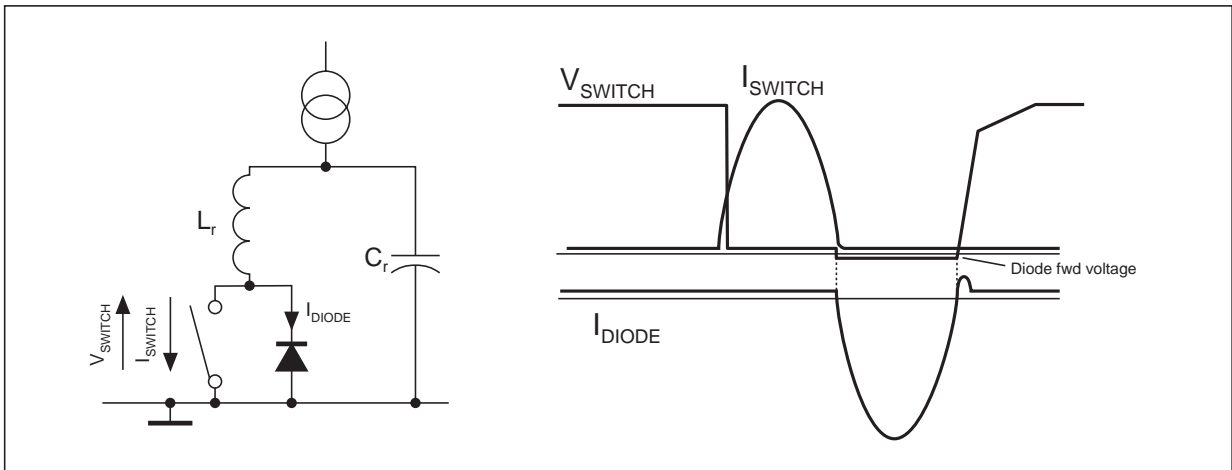

Figure 3. Full-wave zero-voltage switch - topology and waveforms

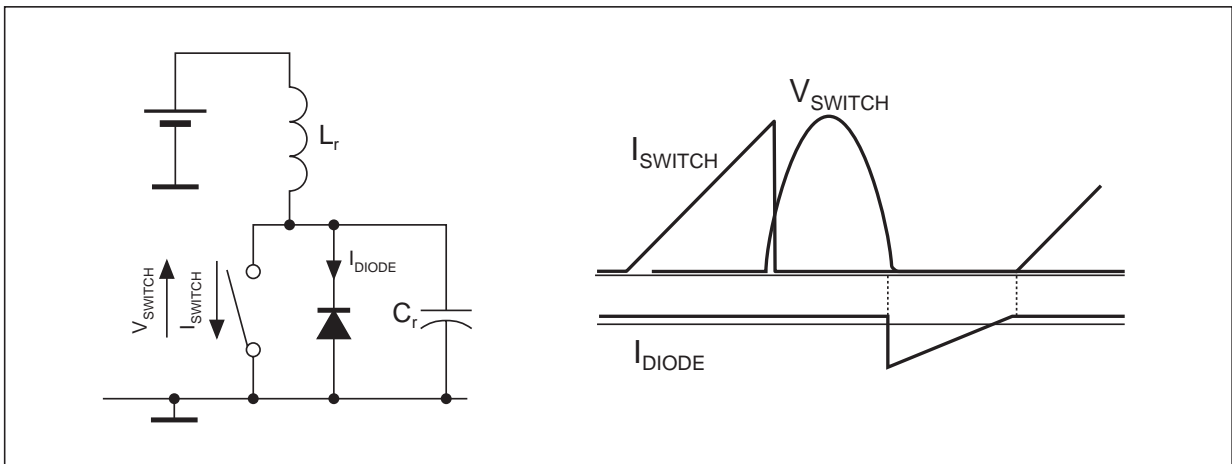
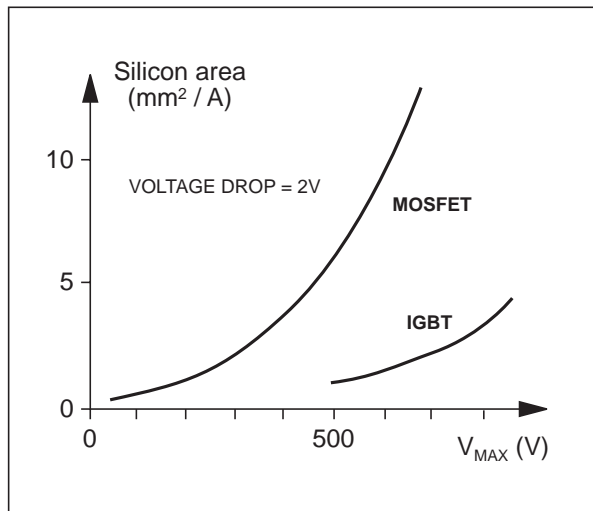

Figure 4. Comparison of MOSFET and IGBT



the die size required is almost constant approaching the maximum rated voltage.

4.1 MOSFETs

The MOSFET has a resistive behaviour in its on state, and the output characteristic passes through zero. It can conduct a small current with a very low voltage drop.

4.1.1 Zero Current Switch

A MOSFET can be modelled as an ideal switch with a series resistance, and a capacitor connected in parallel - see figure 5. Every time it is turned on, the parallel capacitor is discharged through the resistance and $(0.5 \times C_{out} \times V_{DS})$ units are lost. A MOSFET in a Zero Current Switch will have to turn on with a high drain-source voltage, and there will be capacitive switching losses. Additionally, the reactive overcurrent in the switch is very high, and as the MOSFET does not perform well in overcurrent conditions, the conduction losses will be very high. Therefore the MOSFET is not very suitable as a Zero Current Switch.

4.1.2 Zero Voltage Switch

In a Zero Voltage Switch, the MOSFET turns on without any voltage between drain and source, and so there are no capacitive switching losses. There is no reactive overcurrent and the conduction losses are not very important. The MOSFET does have to turn off a current, but as the switching times of a MOSFET are small, the turn off losses will not be excessive.

Figure 5. Simple MOSFET model

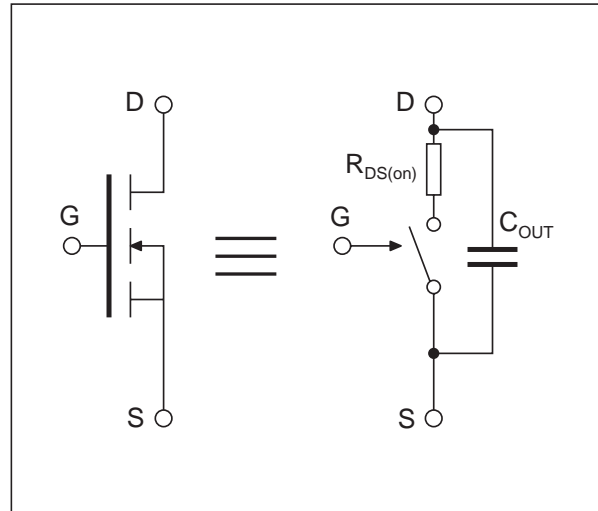

4.2 IGBTs

The IGBT has a threshold voltage of around 0.7V; a voltage drop lower than this value is not possible. The "resistive part" of the output characteristics of an IGBT is very low, and so it can conduct large currents with a low voltage drop. It is thus most suitable for use at high current densities.

An IGBT can be simply modelled as a pnp-transistor driven by a MOSFET. The disadvantage of this structure is the turn off. If a pnp transistor is to be turned off quickly, a positive base current must be supplied, to force the carriers in the base to recombine and stop the device conducting. In the IGBT, the base of the pnp stage cannot be accessed directly, and so this current cannot be delivered at turn off, meaning that the device continues to conduct while the carriers recombine "naturally". During this time, a current tail appears.

4.2.1 Zero Voltage Switch

In a Zero Voltage Switch, the IGBT must turn off a current. Even if the voltage across the switch rises with a limited dV/dt (sinusoidal waveform), the current tail phenomenon means that turn off losses will be important. Therefore the IGBT is not very suitable for zero voltage switching.

4.2.2 Zero Current Switch

In a Zero Current Switch, the external circuit defines the current in the switch. This current tends to zero, and hence the IGBT does not turn off current, so no tail appears. Another problem that can occur with

APPLICATION NOTE

the IGBT, latching, does not occur in this mode. Even if the IGBT latches at the maximum current, it can turn off later because the current is defined by the external circuit. The carriers that remained in the base of the pnp-transistor can be recovered by a positive current into the base. In a Zero Current Switch, the negative half wave of the resonant current flows through the antiparallel diode. During that time, a negative voltage is applied to the IGBT. A current flows through the body diode of the internal MOSFET into the base of the pnp-transistor.

5. TWO-SWITCH RESONANT CONVERTERS

As in standard power converters, for higher power applications, two switches can be connected as shown in figure 6 to form a half-bridge resonant converter. The same passive components are used for the resonance of both switches, and a transformer has been added to drive the load.

5.1 Thyristor Mode

In the example above, the commutation frequency of the switches (f_{sw}) is lower than the resonant frequency of the circuit (f_0). This results in a "dead" zone in the transformer waveform, giving a poor overall efficiency. If the switching frequency is increased, as shown in figure 8, the resonant waveforms overlap and the transformer is used more

efficiently. However, the switch now has to turn on at a non-zero current level, and as the diodes turn off at a high current level (e.g. point A in figure 7), losses due to their recovery time will be high.

5.2 Dual Thyristor Mode

The effect of the diode recovery time can be reduced by increasing the switching frequency further - see figure 8. In this case, the diode turns off at zero current.

The main advantage of this type of circuit is that the intrinsic diode of the MOSFET, which has very poor reverse recovery characteristics, can be used in the circuit, removing the need for a further discrete diode.

CONCLUSIONS

Resonant converter topologies can be used to increase circuit switching speeds, allowing the cost of circuit magnetics to be reduced, while still keeping switching losses to a minimum. Full wave rather than half wave topologies are generally used, as they generate less EMI. Capacitive switching losses when turning on with a high drain-source voltage means that MOSFETs are more suitable for Zero-Voltage than Zero-Current switches, while its poor turn-off characteristics mean that the IGBT is more suited to Zero-Current topologies.

Figure 6. Half-Bridge Zero-Current resonant converter

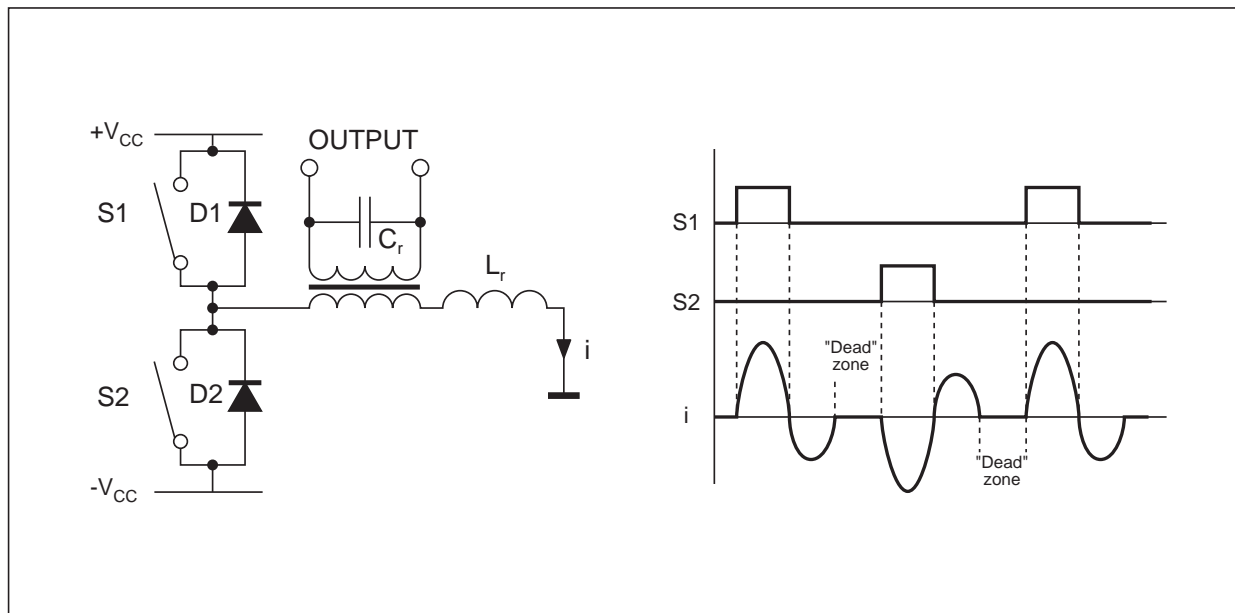
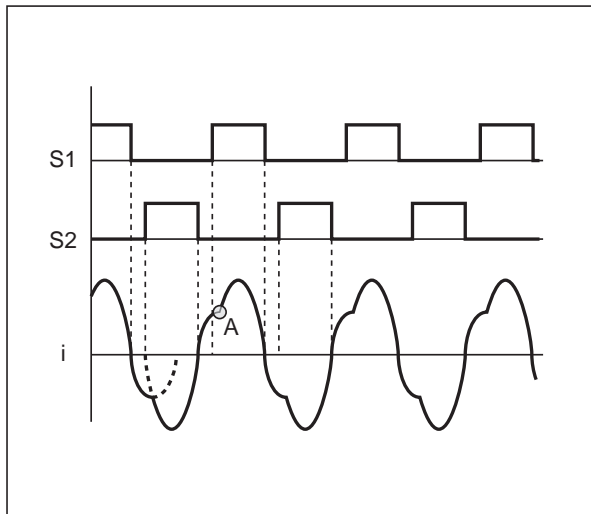
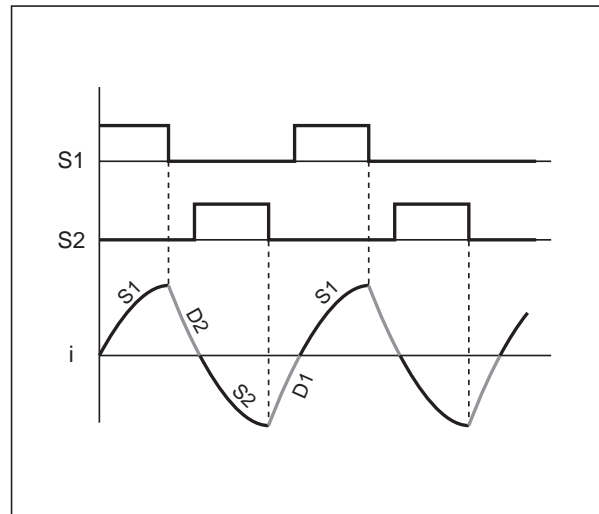

Figure 7. Half-Bridge waveforms with $f_{sw} > f_0$ Figure 8. Half-Bridge waveforms with $f_{sw} \gg f_0$ 

Information furnished is believed to be accurate and reliable. However, STMicroelectronics assumes no responsibility for the consequences of use of such information nor for any infringement of patents or other rights of third parties which may result from its use. No license is granted by implication or otherwise under any patent or patent rights of STMicroelectronics. Specification mentioned in this publication are subject to change without notice. This publication supersedes and replaces all information previously supplied. STMicroelectronics products are not authorized for use as critical components in life support devices or systems without express written approval of STMicroelectronics.

The ST logo is a trademark of STMicroelectronics

© 1999 STMicroelectronics - Printed in Italy - All Rights Reserved

STMicroelectronics GROUP OF COMPANIES

Australia - Brazil - China - Finland - France - Germany - Hong Kong - India - Italy - Japan - Malaysia - Malta - Morocco - Singapore - Spain - Sweden - Switzerland - United Kingdom - U.S.A.

<http://www.st.com>