



Approvals

GAM T1 LISTED

Life expectancy

L-10 LIFE AT 40°C:
25 000 hours

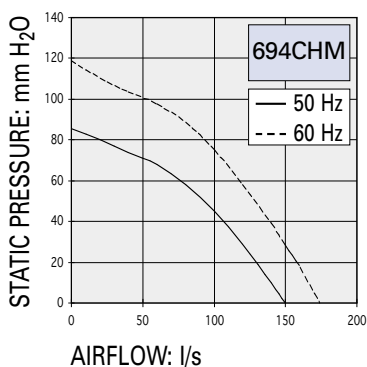

268 x 300 x 254,5 mm

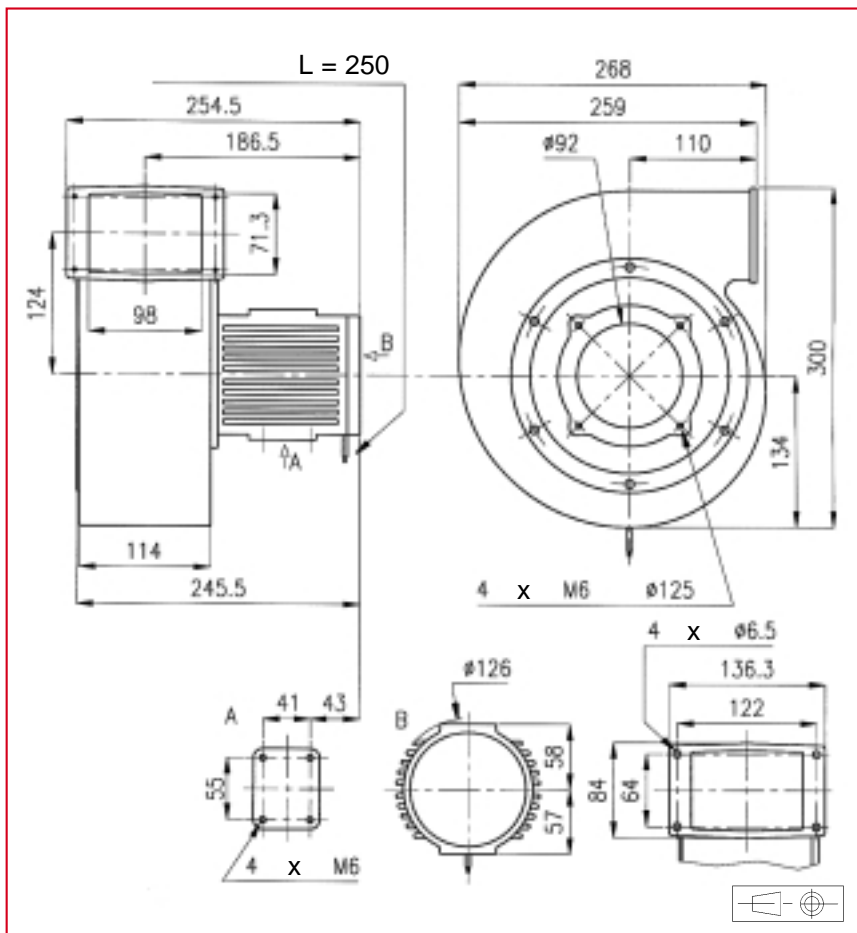

AC Motor

Housing material: aluminium
Wheel material: aluminium
Weight: 6,5 kg
Bearing system: ball bearings

Connection: flying leads

Available with:

- safety switch

Part number	Nominal voltage	Airflow	Noise level	Nominal speed	Frequency	Phases	Capacitor (not included)	Input power	Nominal current	Starting current	Operating temperature	
	V	l/s	dB(A)	RPM	Hz		µF	W	mA	mA	Min. °C	Max. °C
694CHM016DC13	220	150	72	2900	50	3		180	900	4850	-10	70
	380	150	72	2900	50	3		180	950	4300	-10	70
	220	175	75	3300	60	3		265	1000	4600	-10	70
	380	175	75	3300	60	3		265	1300	4000	-10	70
	220	150	72	2900	50	1	12,2	185	950	4300	-10	70
	380	150	72	2900	50	1	4	185	550	2500	-10	70
	220	175	75	3300	60	1	12,2	275	1300	4000	-10	70
	380	175	75	3300	60	1	4	275	800	2350	-10	70

Additional versions:

Salt spray protected - shock and vibration protected - marine specifications - wide temperature range

Accessories:

See pages: 157, 160 and 163