

1,550nm MQW-DFB Modulator Integrated Laser

FLD5F10NP-A

FEATURES

- Modulator Integrated DFB Laser Diode Module
- CW operation of DFB laser section
- Modulation voltage applied only to modulator section
- High speed butterfly package with SMP connection
- Built-in optical isolator, monitor photodiode, thermistor, and thermo-electric cooler
- $\lambda/4$ shifted MQW-DFB chip

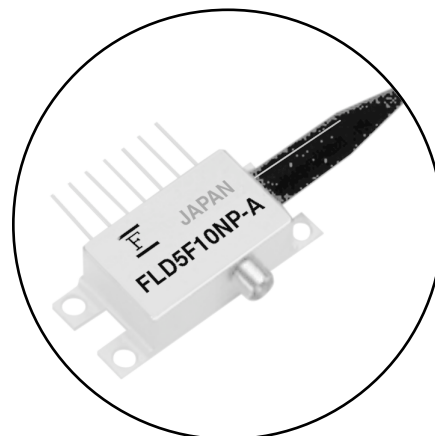

APPLICATION

This MI laser is intended for for short reach applications (<5km) at 10Gb/s.

DESCRIPTION

The Modulator Integrated DFB Laser (MI DFB Laser) has an electro-absorption modulator monolithically integrated with a conventional Distributed Feed-Back (DFB) $\lambda/4$ shifted Multi QuantumWell (MQW) laser. The modulation voltage is applied to the modulator section while the laser section operates CW allowing extremely low wavelength chirping. Extinction ratios of more than 8.3 dB can be achieved with 2.6 Vp-p modulation. The MI laser is installed in a butterfly type package. The module incorporates a highly stable YAG welded optical coupling system. The module includes an optical isolator, monitor photodiode, thermistor and a thermo-electric cooler.

ABSOLUTE MAXIMUM RATINGS (T_{op}=25°C, unless otherwise specified)

Parameter	Symbol	Condition	Ratings	Unit
Operating Case Temperature	T _{op}	-	-20 to +65	°C
Storage Temperature	T _{stg}	-	-40 to +70	°C
Optical Output Power	P _f	CW	5	mW
Laser Forward Current	I _F	CW	150	mA
Laser Reverse Voltage	V _R	CW	2	V
Modulator Forward Voltage	V _M	CW	-5 to +1	V
Photodiode Forward Current	I _{DF}	-	1	mA
Photodiode Reverse Voltage	V _{DR}	-	10	V
TEC Voltage	V _C	-	2.5	V
TEC Current	I _C	-	1.4	A
Lead Soldering Time	T _{sold}	260°C	10	sec

OPTICAL & ELECTRICAL CHARACTERISTICS (T_L= T_{set}, T_C = 25°C, BOL, unless otherwise specified)

Parameter	Symbol	Test Condition	Limits			Unit
			Min.	Type	Max.	
On Level Modulation	V _O	-	-1	-0.3	0	V
Modulator Drive Voltage	V _{mod}	(V _O -V _{mod})>=-3.3V, R _{ext} =8.3dB	-	-	2.6	V
Threshold Current	I _{th}	CW, V _m =V _O	-	-	30	mA
Operating Current	I _{op}	CW, V _m =V _O	50	-	100	mA
Dispersion Penalty	dP	Note (1)	-	-	2	dB
Optical Output Power (Avg. Power)	P _f	Note (1)	-2	-	-	dBm
Forward Voltage	V _F	CW, I _F =I _{op} , V _m =V _O	-	1.4	2.0	V
Extinction Ratio	R _{ext}	f=10Gb/s, I _F =I _{op} , V _m =V _O /(V _O -V _{mod})	8.3	-	-	dB
Peak Wavelength	λ _p	Note (2)	1530	-	1565	nm
Sidemode Suppression Ratio	SSR	Note (2)	35	-	-	dB
Rise Time	T _r	Note (2), 20 to 80%	-	20	40	ps
Fall Time	T _f	Note (2), 20 to 80%	-	20	40	ps
Input Impedance	Z	CW, V _m <0	-	50	-	Ω
RF Return Loss	S ₁₁	f=CD-5GHz, 50Ω Test Set, V _m =V _O , I _F =I _{op}	8	-	-	dB
RF Return Loss	S ₁₁	f=5-10GHz, 50Ω Test Set, V _m =V _O , I _F =I _{op}	3	-	-	dB
Cut-off Frequency	S ₂₁	-3dB bandwidth, V _m =V _O -0.5(V _{mod}), I _F =I _{op}	10	-	-	GHz
Relative Intensity Noise	RIN	f=10 GHz, V _m =V _O , I _F =I _{op} , ORL=>24dB	-	-	-120	dB/Hz
Optical Isolation	I _s	T _c =-20 to +65°C	25	35	-	dB

Note (1) FUJITSU Test System
9.95328Gb/s, PRBS, 2²³-1, I_F=I_{op}, V_m=V_O and (V_O-V_{mod})
Dispersion=82ps/nm, Dispersion penalty at
Bit Error Rate = 1.0E-10

Note (2) FUJITSU Test System
9.95328Gb/s, PRBS, 2²³-1, I_F=I_{op}, V_m=V_O and (V_O-V_{mod})

Fig. 1 Lasing Spectrum

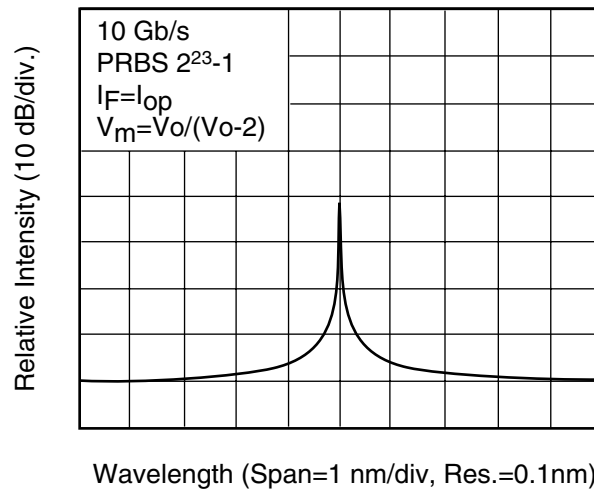
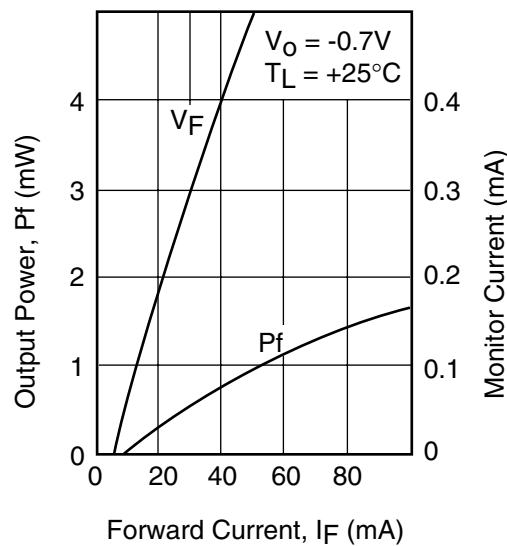

Fig. 2 Forward Current vs. Output Power and Forward Current vs. Forward Voltage



www.DataSheet4U.com

Fig. 3 Extinction Ratio vs. Modulation Voltage

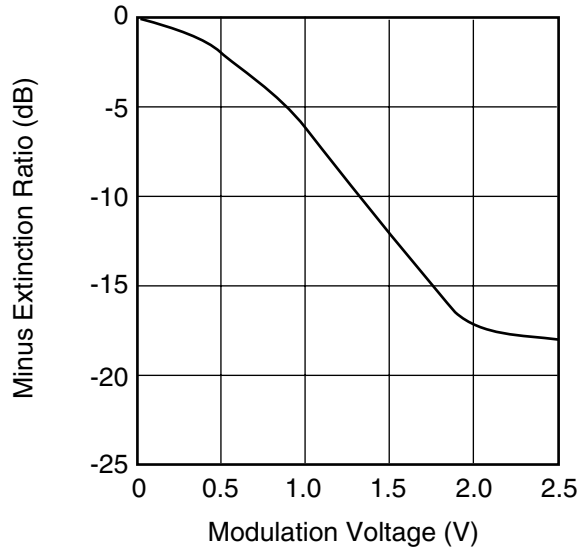

Fig. 4 Cut-off Frequency (S21)

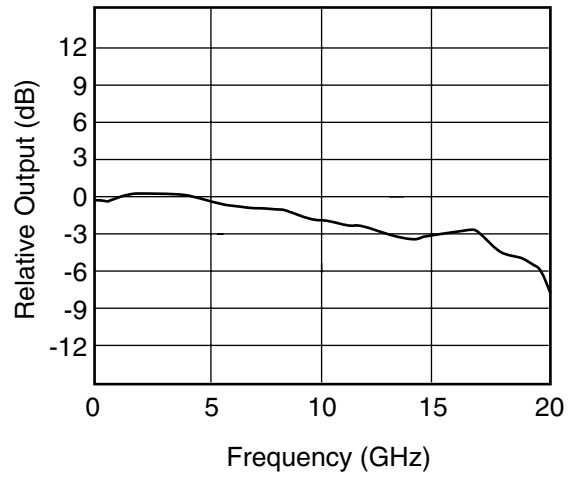

Fig. 5 RF Return Loss (S11)

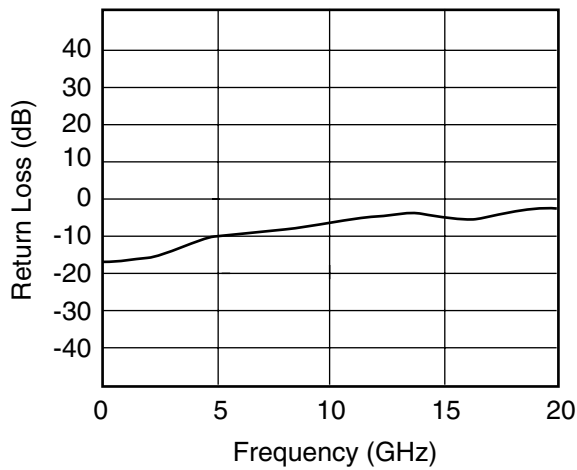
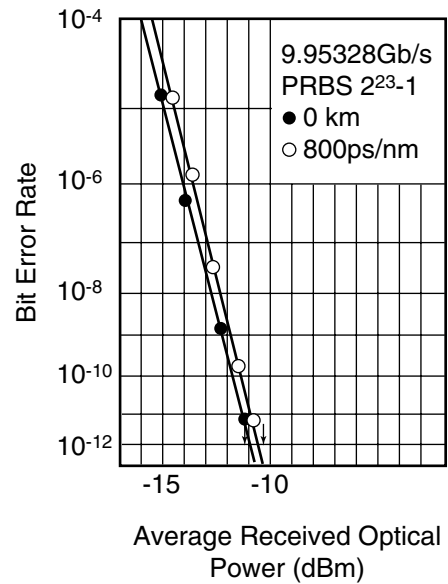

Fig. 6 Transmission Characteristics



**1,550nm MQW-DFB
Modulator Integrated Laser**

FLD5F10NP-A

Notes [aSheet4U.com](http://www.DataSheet4U.com)

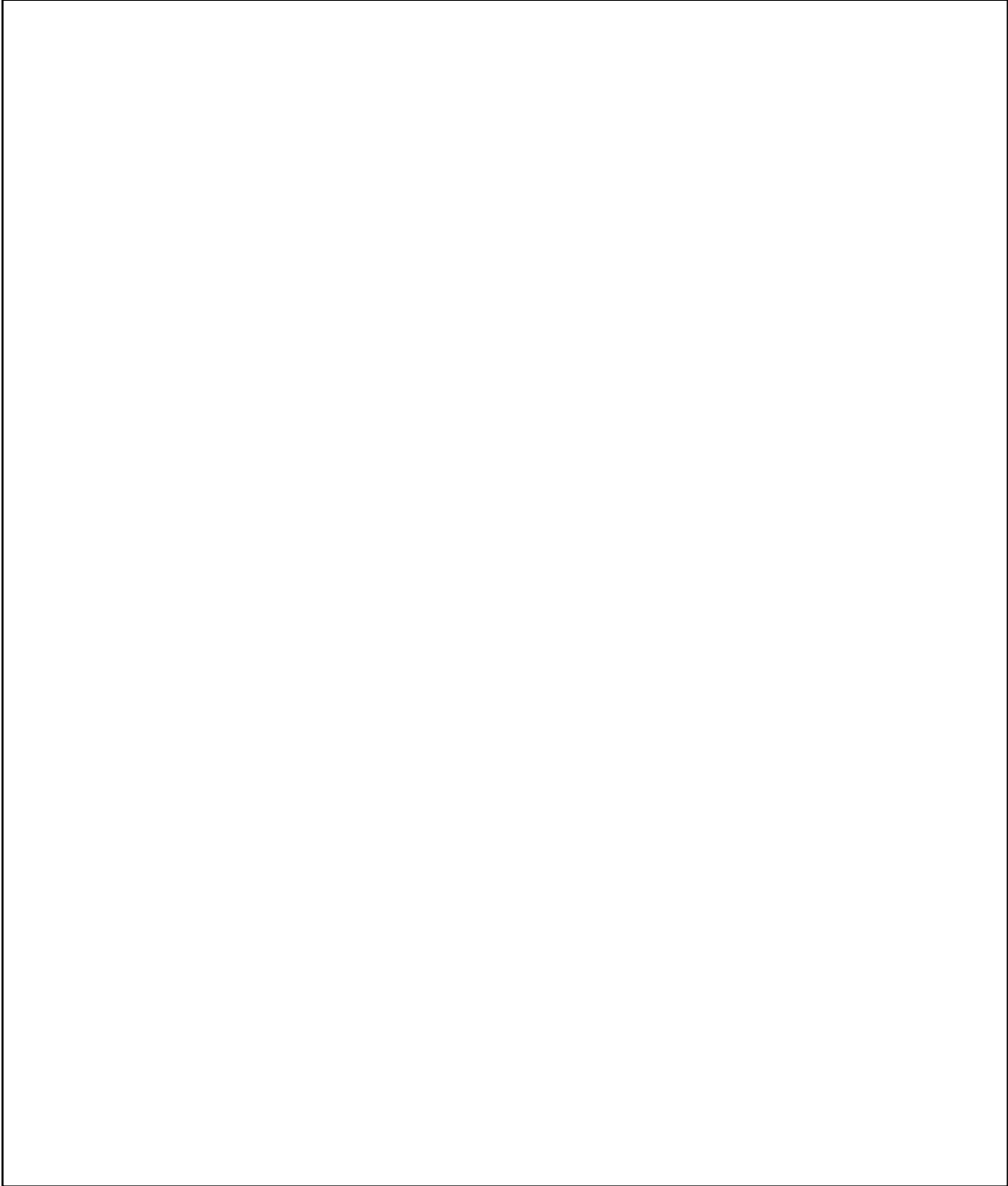

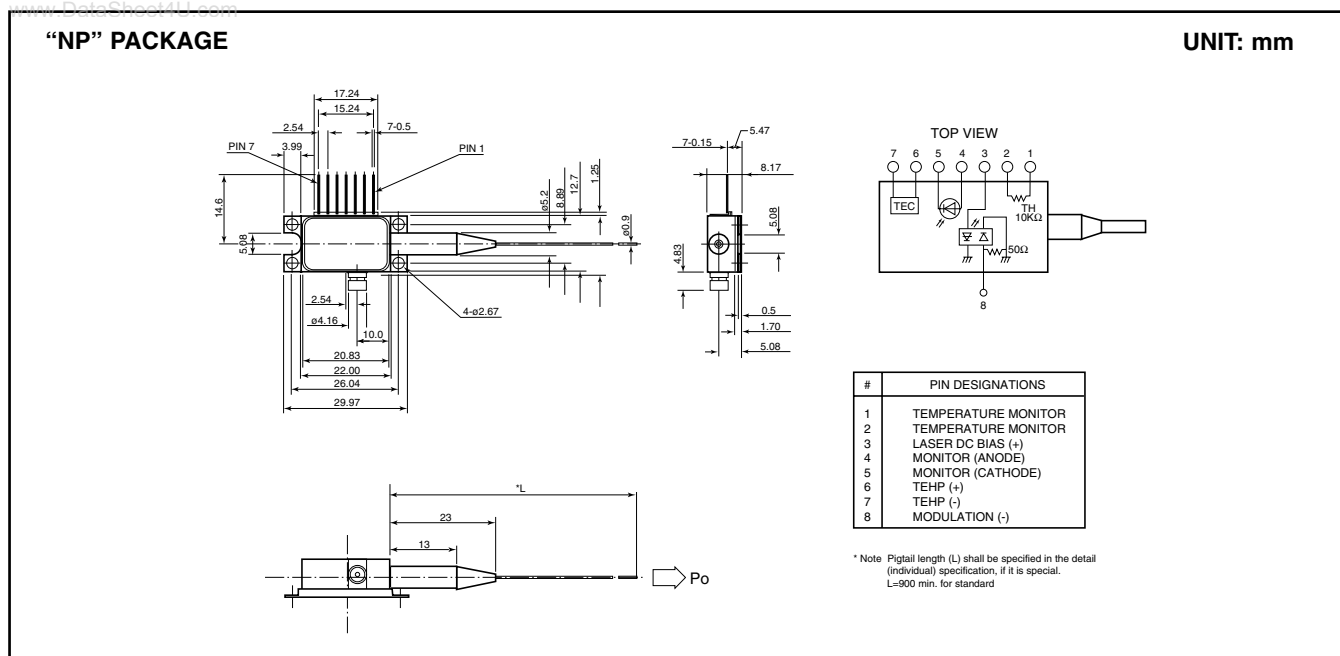

For further information please contact:

FUJITSU COMPOUND SEMICONDUCTOR, INC. Americas & R.O.W.

2355 Zanker Rd.
San Jose, CA 95131-1138, U.S.A.
Phone: (408) 232-9500
FAX: (408) 428-9111
www.fcsi.fujitsu.com

FME, QDD

Fujitsu Microelectronics Europe GmbH
Quantum Devices Division
Network House
Norreys Drive
Maidenhead, Berkshire SL6 4FJ
United Kingdom
TEL: +44 (0) 1628 504800
FAX: +44 (0) 1628 504888

FUJITSU QUANTUM DEVICES SINGAPORE PTE LTD.

Hong Kong Branch
Rm. 1101, Ocean Centre, 5 Canton Rd. Tsim Sha Tsui,
Kowloon, Hong Kong
TEL: +852-23770226
FAX: +852-23763269

Fujitsu Limited reserves the right to change products and specifications without notice.
The information does not convey any license under rights of Fujitsu Limited or others.

© 2000 FUJITSU COMPOUND SEMICONDUCTOR, INC.
Printed in U.S.A. FCSI0200M200

CAUTION

Fujitsu Compound Semiconductor Products contain **gallium arsenide (GaAs)** which can be hazardous to the human body and the environment. For safety, observe the following procedures:

- Do not put this product into the mouth.
- Do not alter the form of this product into a gas, powder, or liquid through burning, crushing, or chemical processing as these by-products are dangerous to the human body if inhaled, ingested, or swallowed.
- Observe government laws and company regulations when discarding this product. This product must be discarded in accordance with methods specified by applicable hazardous waste procedures.

FUJITSU QUANTUM DEVICES LIMITED

Global Business Division
Global Sales Support Department
Shinjuku Daiichiseimei Building, 2-7-1 Nishishinjuku,
Shinjuku-ku, Tokyo, 163-0721, Japan
TEL: +81-3-5322-3356
FAX: +81-3-5322-3398